

# Using EVM to Assess the Quality of Power Management Circuits in RF Signal Chains

Eamon Nash – Analog Devices

# Power Management Recommendation for Typical Single Positive Supply LNA

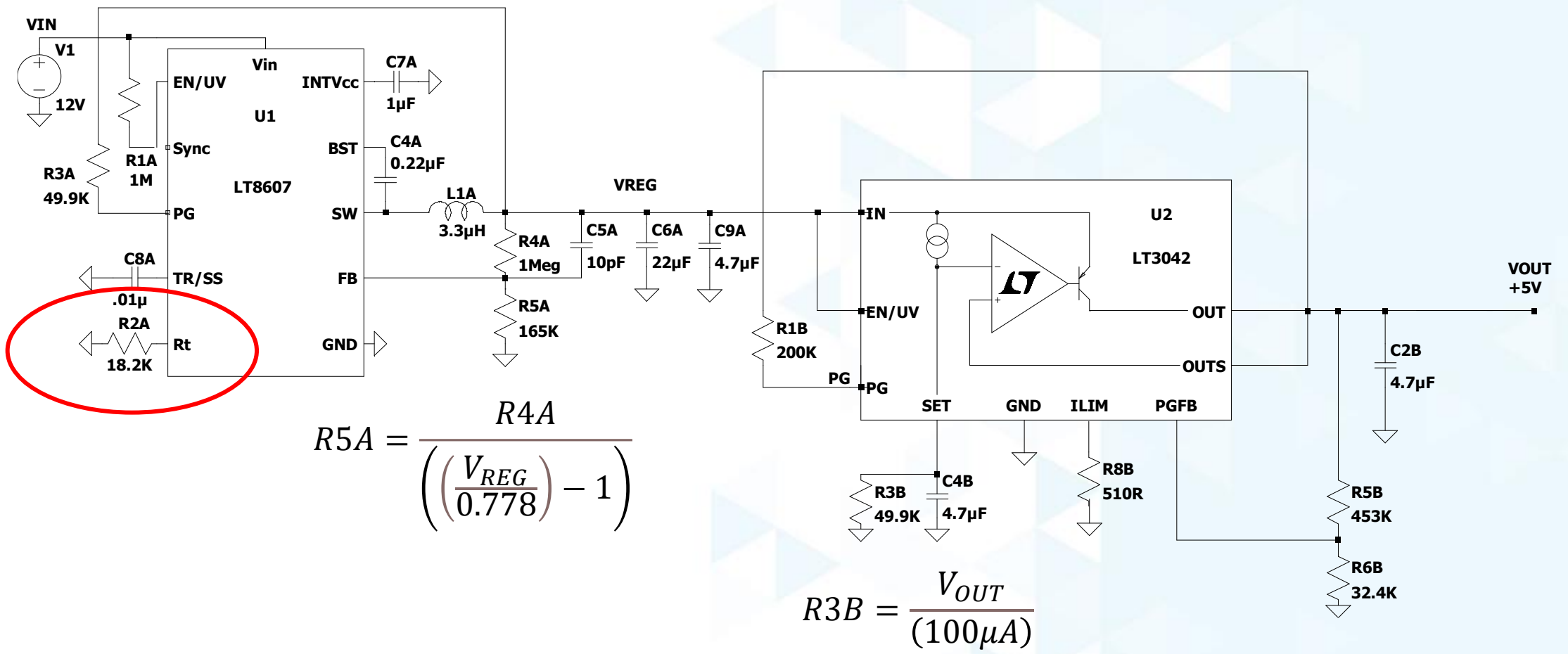

# Silent Switcher Technology

- Ultralow EMI Emissions  
High Efficiency at High Switching Freq
- Integrated Bypass Capacitors  
Eliminates PCB layout sensitivity
- Ultralow LF Noise (0.1Hz to 100kHz)  
Ultrafast Transient Response

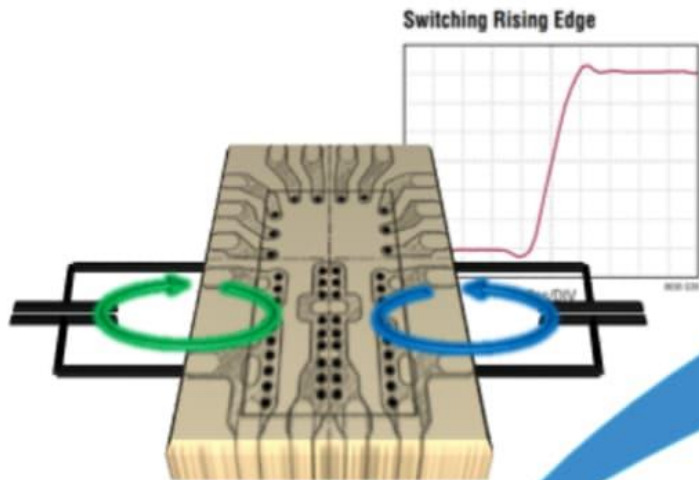
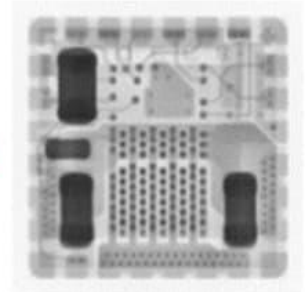
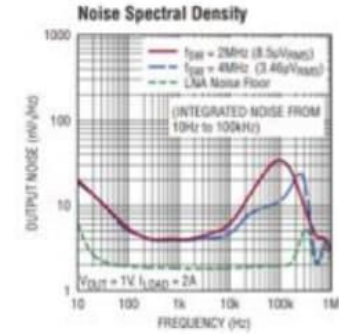

**Silent Switcher<sup>®1</sup>**

**Silent Switcher<sup>®2</sup>**

**Silent Switcher<sup>®3</sup>**

# Goal of Study

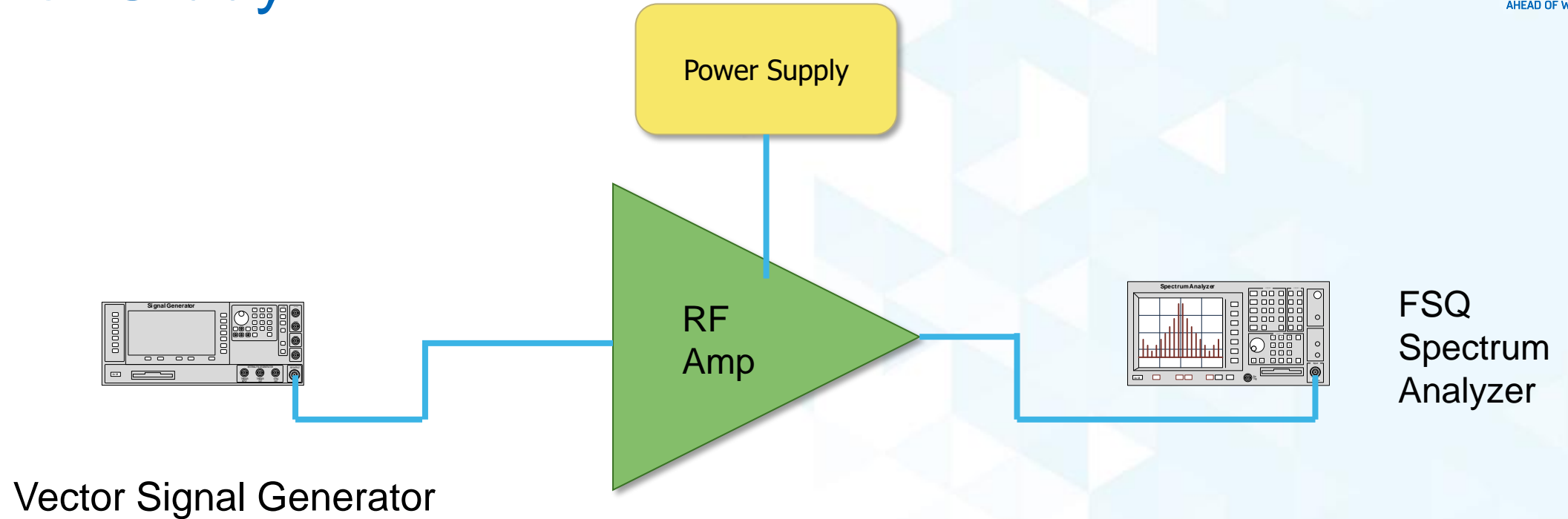

- ▶ Compare the performance of Silent Switcher 3 to a more traditional power management scheme as a power supply for RF components.
- ▶ Use EVM degradation as a performance metric.

# Error Vector Magnitude

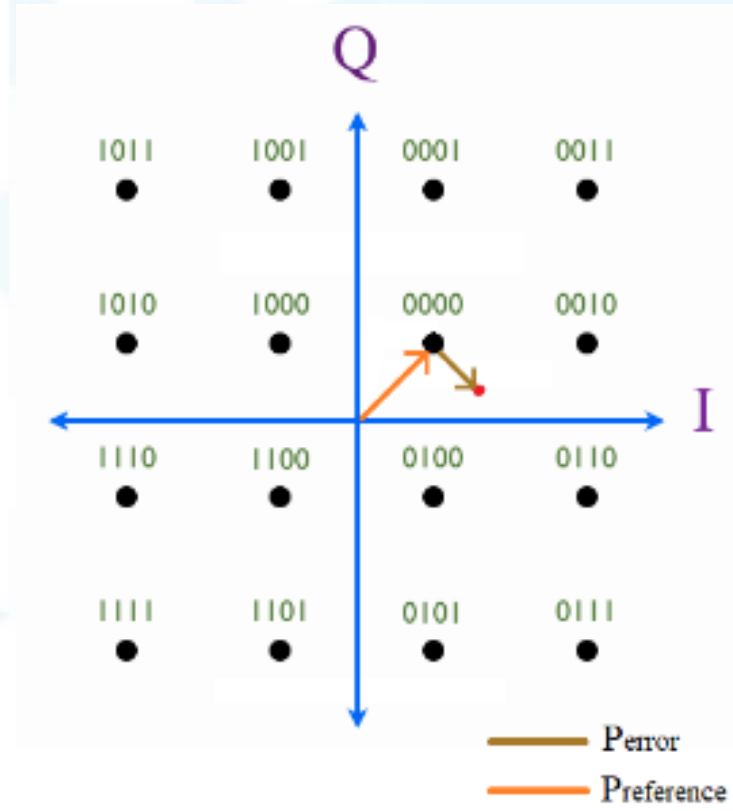
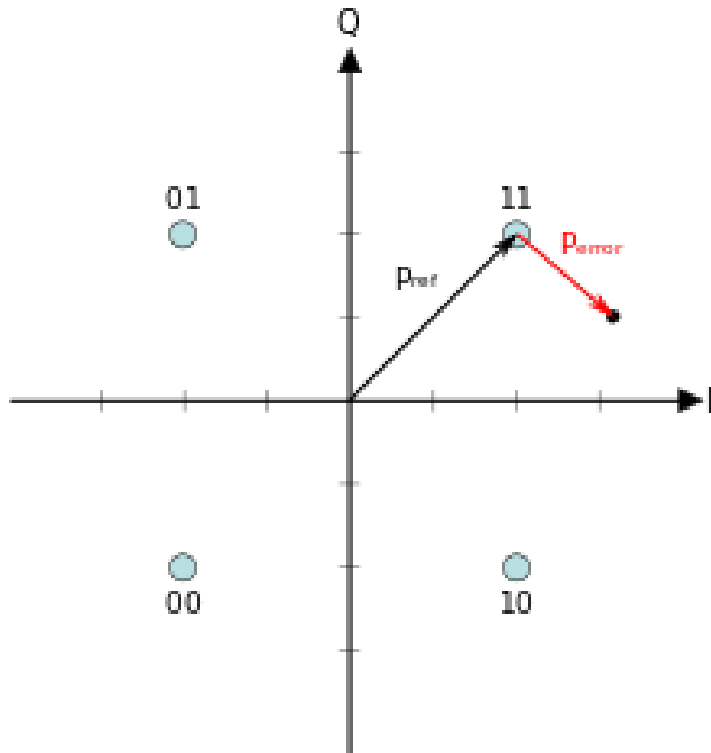

# Error Vector Magnitude - EVM

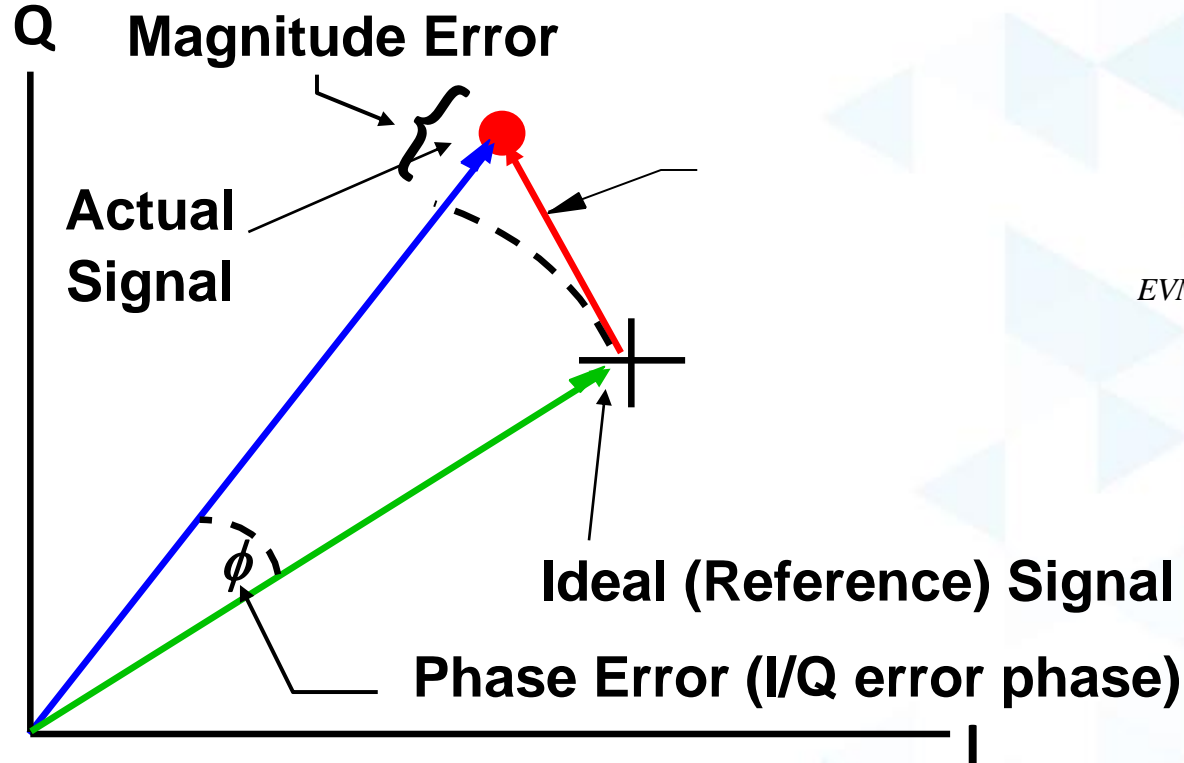

$$EVM = \sqrt{\frac{\sum_{k=1}^M |Z(k) - R(k)|^2}{\sum_{k=1}^M |R(k)|^2}} \quad \text{Unit = \%}$$

- ▶ Noise and Imperfections in transmit and receive signal chains result in demodulated voltages which are displaced from their ideal location.
- ▶ Error Vector Magnitude expresses this dislocation
- ▶ Noise will not shift the average location of the symbol but will still degrade the EVM

# Test Description

- ▶ Measure Noise Figure, Residual Phase Noise and EVM vs Pout of HMC8412 LNA when powered by
  - Keysight E3631 power supply,
  - LT3042 Low Noise LDO
  - LTM402 Silent Switcher 3.
- ▶ Modulation: 64 QAM, 1 MSPS, 0.35 RC Modulation Filter, 6.09 dB PAR
- ▶ Signal Source: R&S SMJ
- ▶ Vector Signal Analyzer: R&S FSQ
- ▶ RF Amp: HMC8412, 0.4 GHz to 11 GHz LNA

# Measurement Setup

E3631 Keysight  
Power Supply

LTM402 Eval Board

Default Eval Board Setups used  
apart from changing Vout resistor

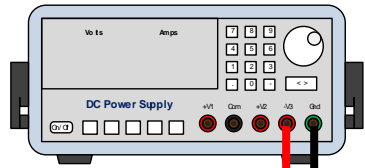

+7V

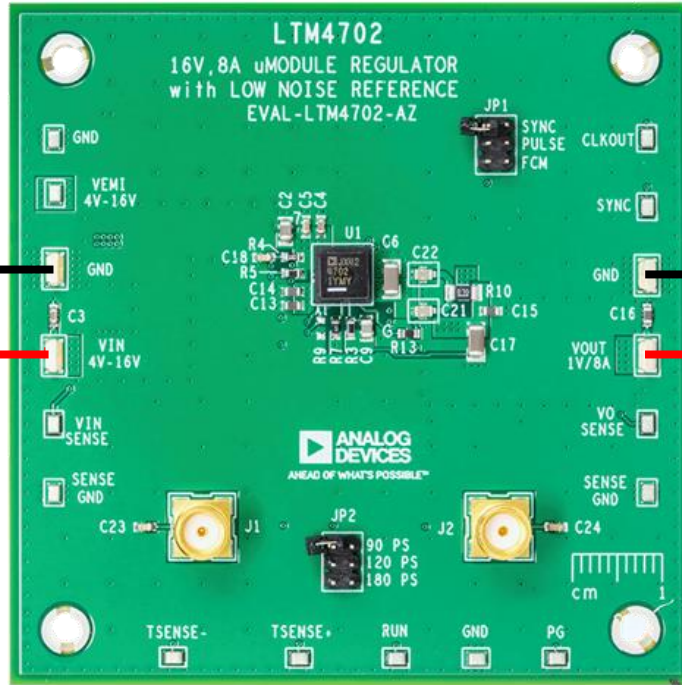

+5V

FSQ  
Vector  
Spectrum  
Analyzer

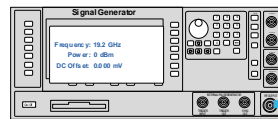

SMJ Vector Signal Generator  
(64 QAM, 1MSPS, EVM  $\approx$  0.15 %)

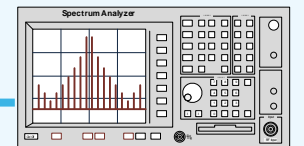

HMC8412 Eval Board

# EVM vs. Output Power at 1 GHz

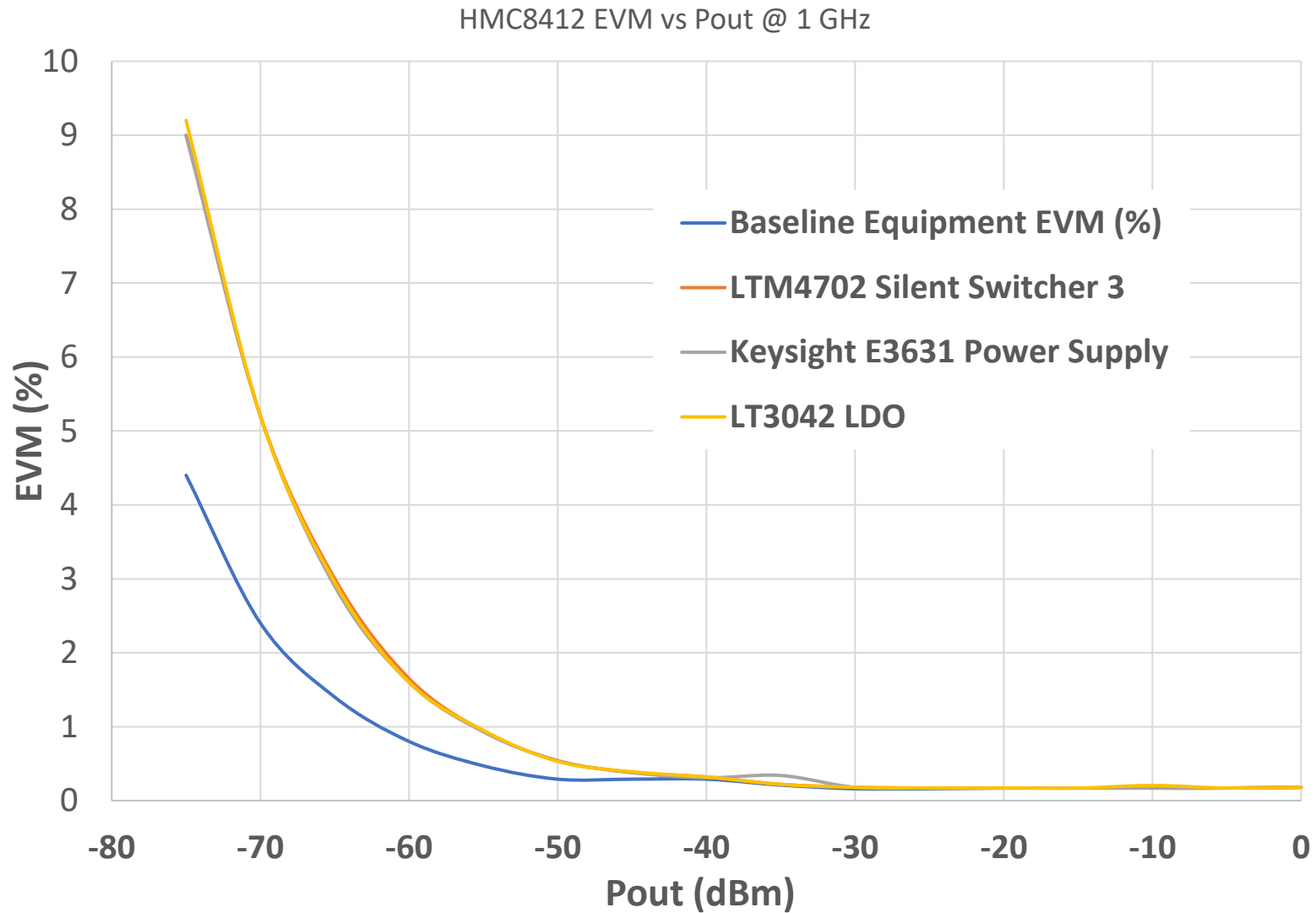

▶ aaa

# Noise Figure

DC Power Source	Frequency (GHz)	Noise Figure (dB)
LTM4702 (SS3)	1	1.63
LT3042 (LDO)	1	1.73
LTM4702	6	1.75
LT3042	6	1.65

- ▶ Measurements are relative. Board losses have not been calibrated out.

# HMC8412 Output Spectrum

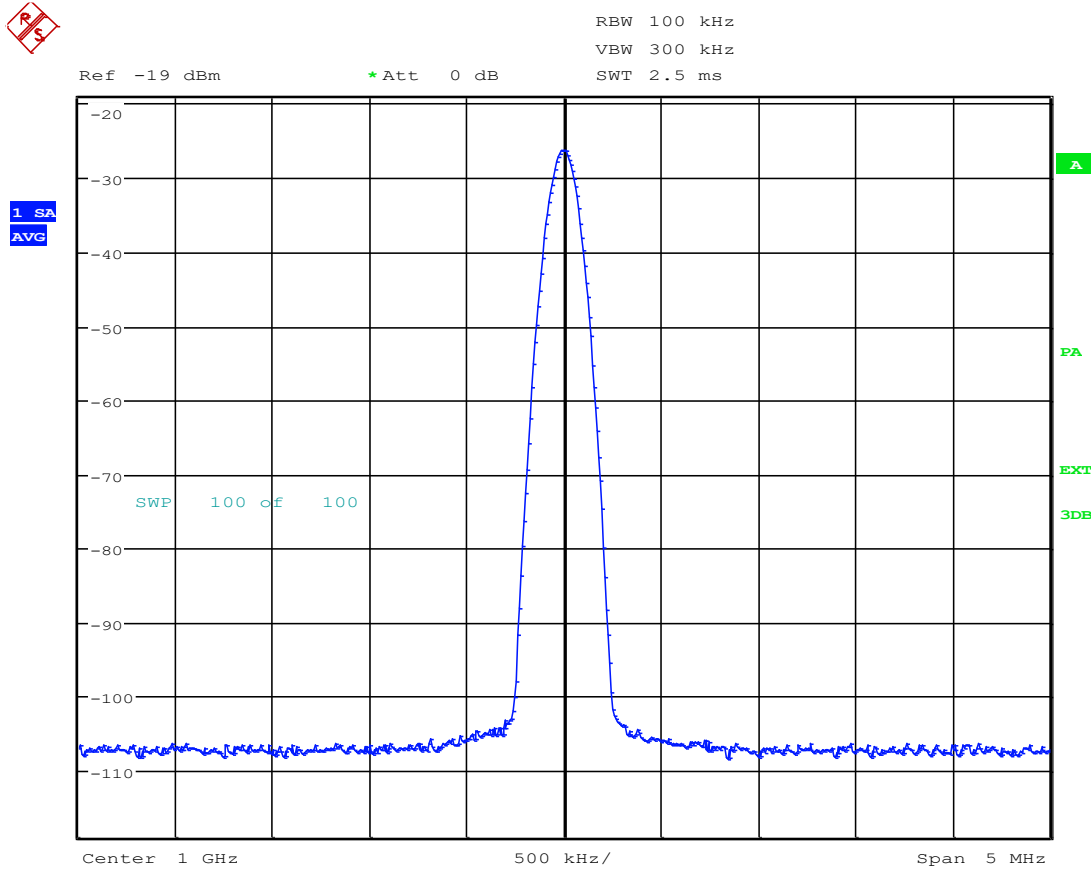

▶ HMC8412 Output Frequency = 1 GHz

Date: 8.AUG.2024 13:46:48

▶ LTM4702: 5V/800KHz

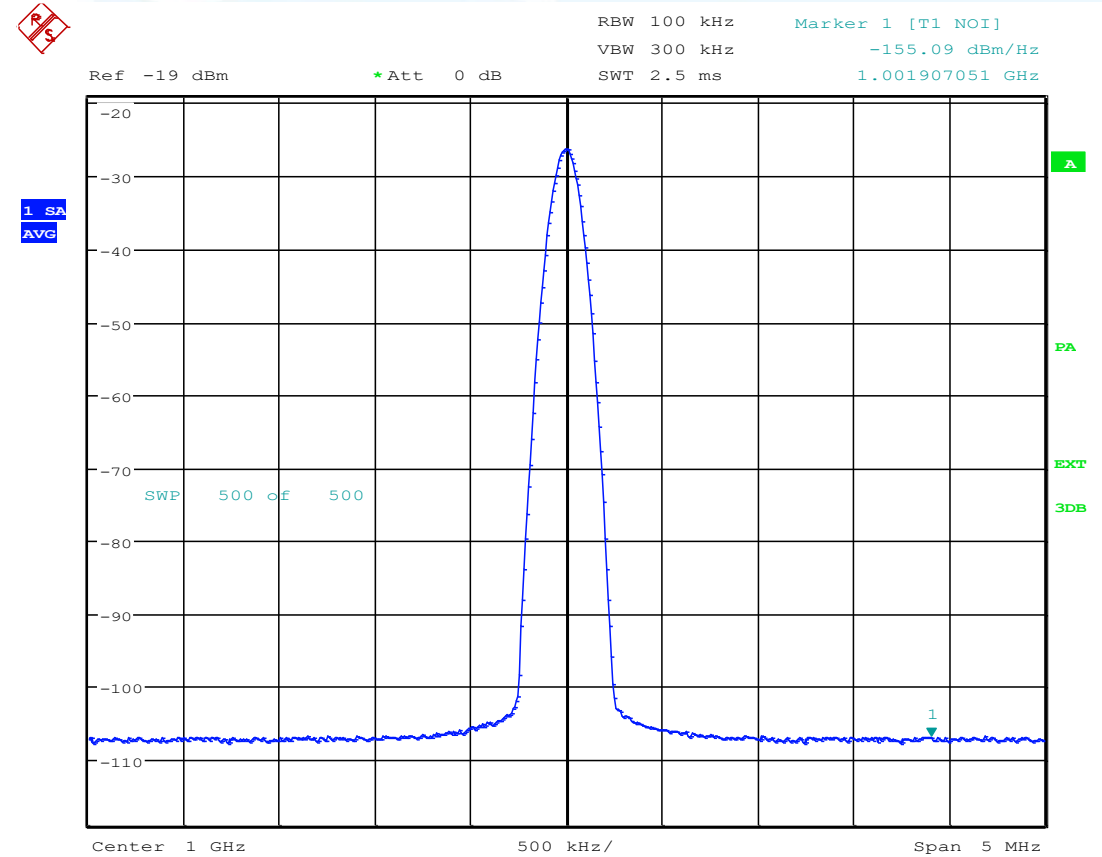

▶ HMC8412 Output Frequency = 1 GHz

Date: 8.AUG.2024 13:48:00

▶ LTM4702: 5V/1.9 MHz

# HMC8412 Output Spectrum – High Power 6 GHz

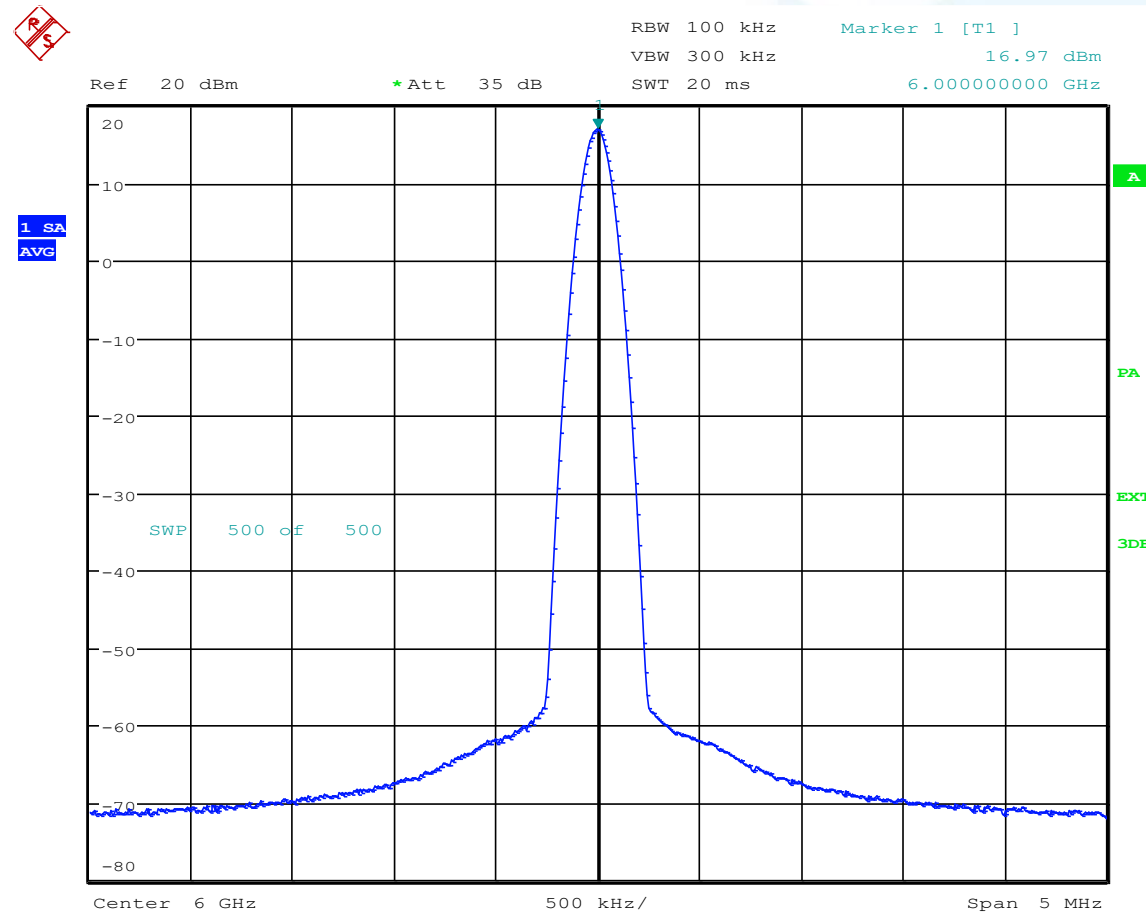

▶ HMC8412 Output Frequency = 6 GHz

▶ CCCC

Date: 9.

▶ LTM4702: 5V/1.9 MHz

# HMC8412 Residual Phase Noise, Pout = 0 dBm, Freq = 6 GHz

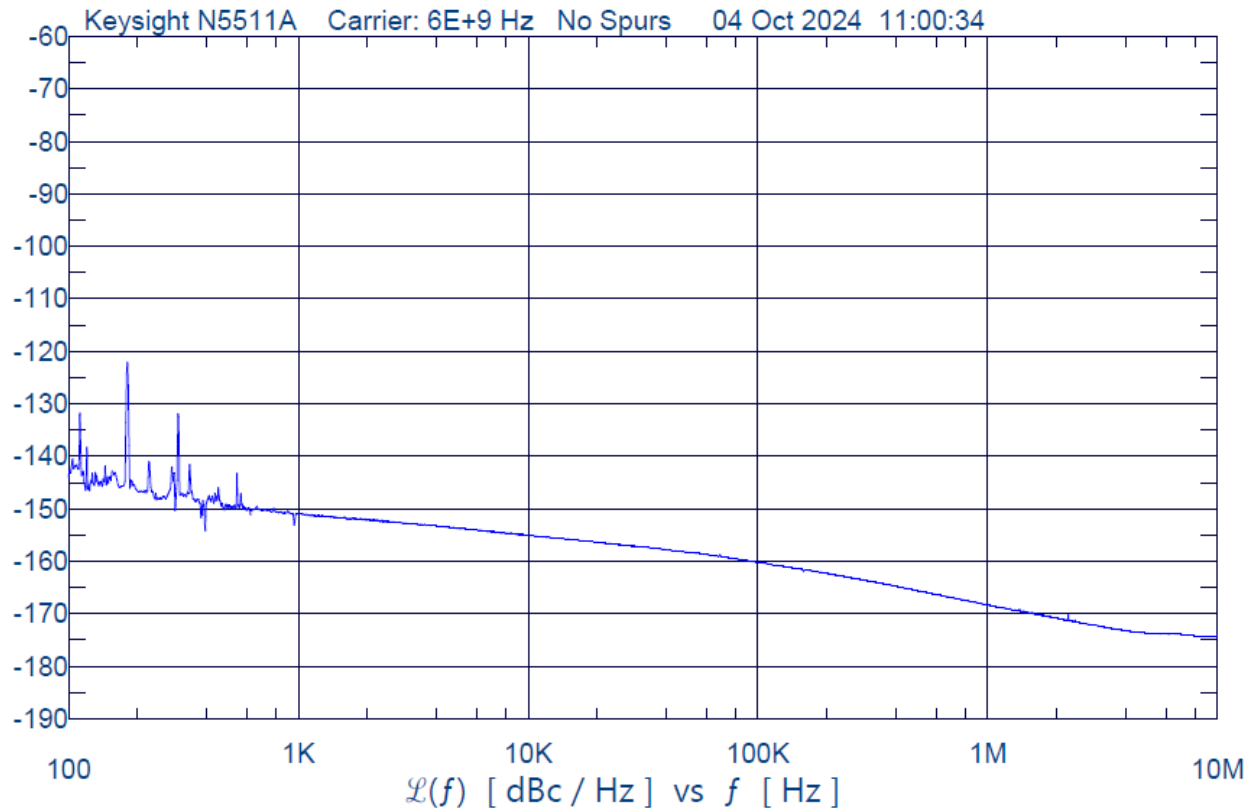

DC Power from Phase Noise Analyzer

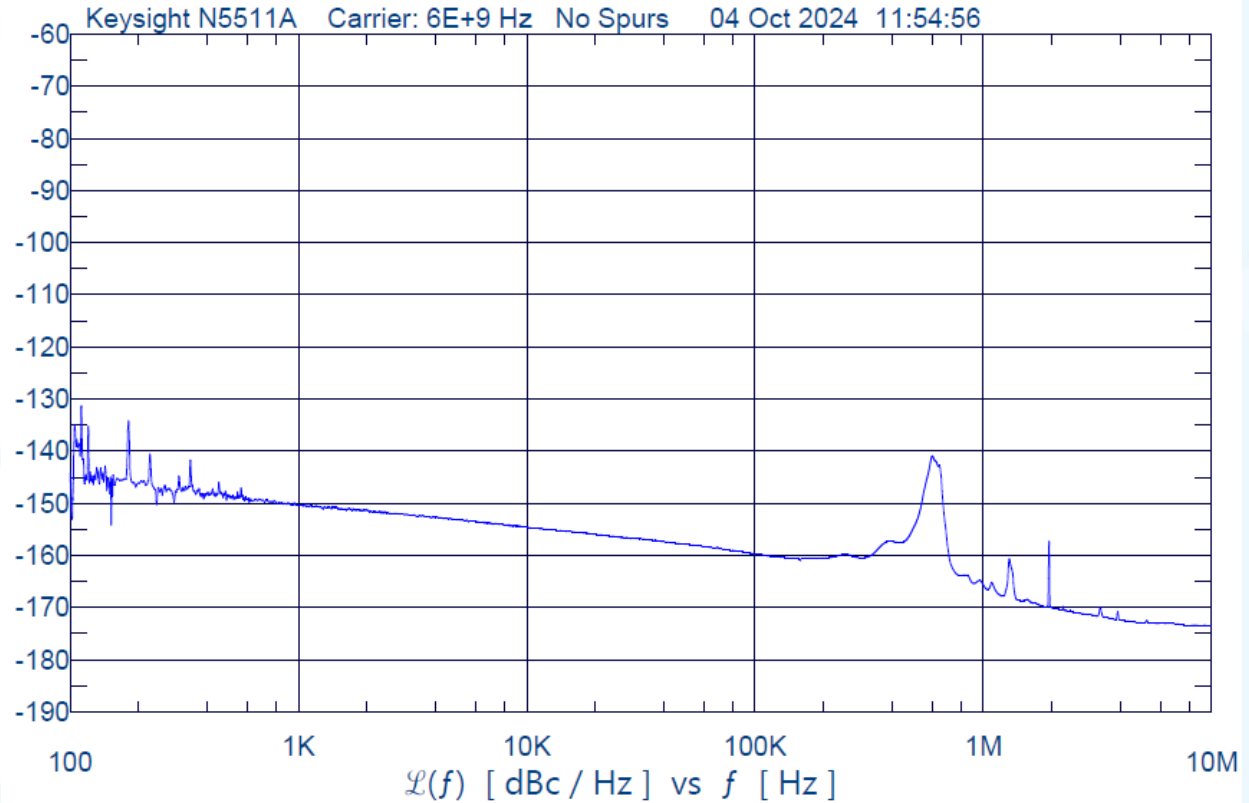

DC Power from LTM4702

► CCCC

# HMC8412 Residual Phase Noise, Pout = 6 dBm, Freq = 6 GHz

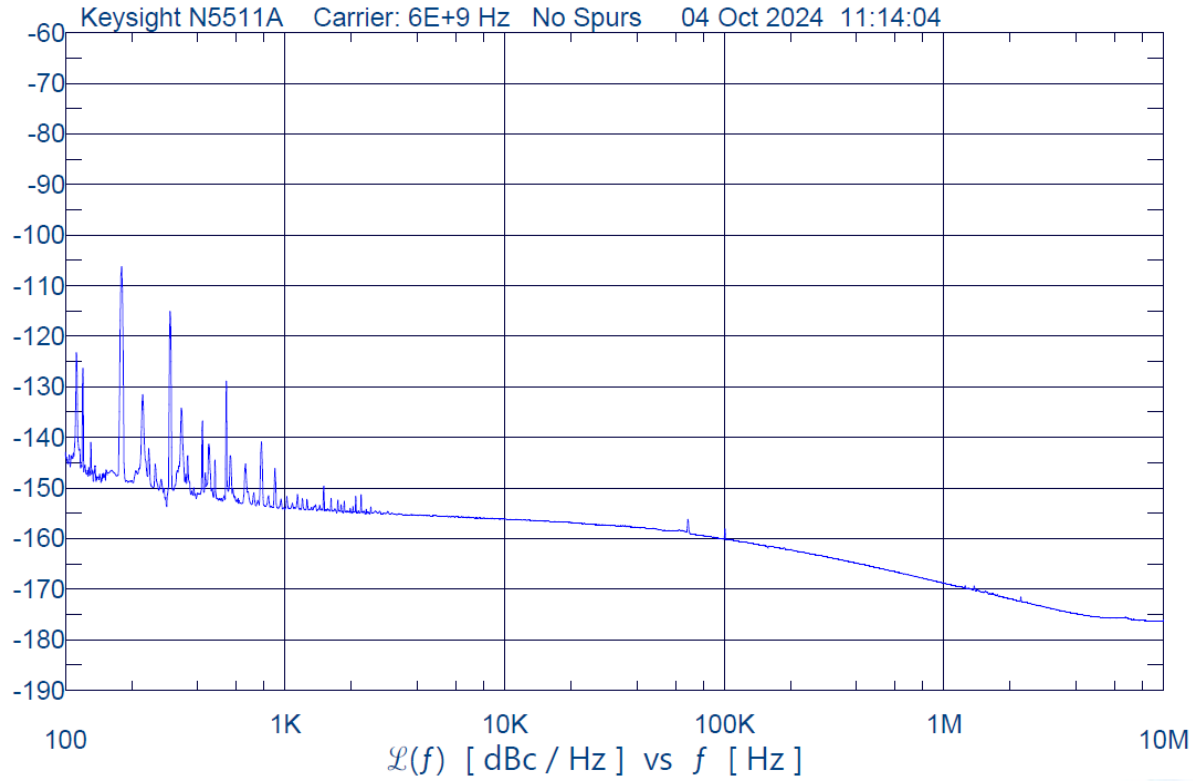

DC Power from Phase Noise Analyzer

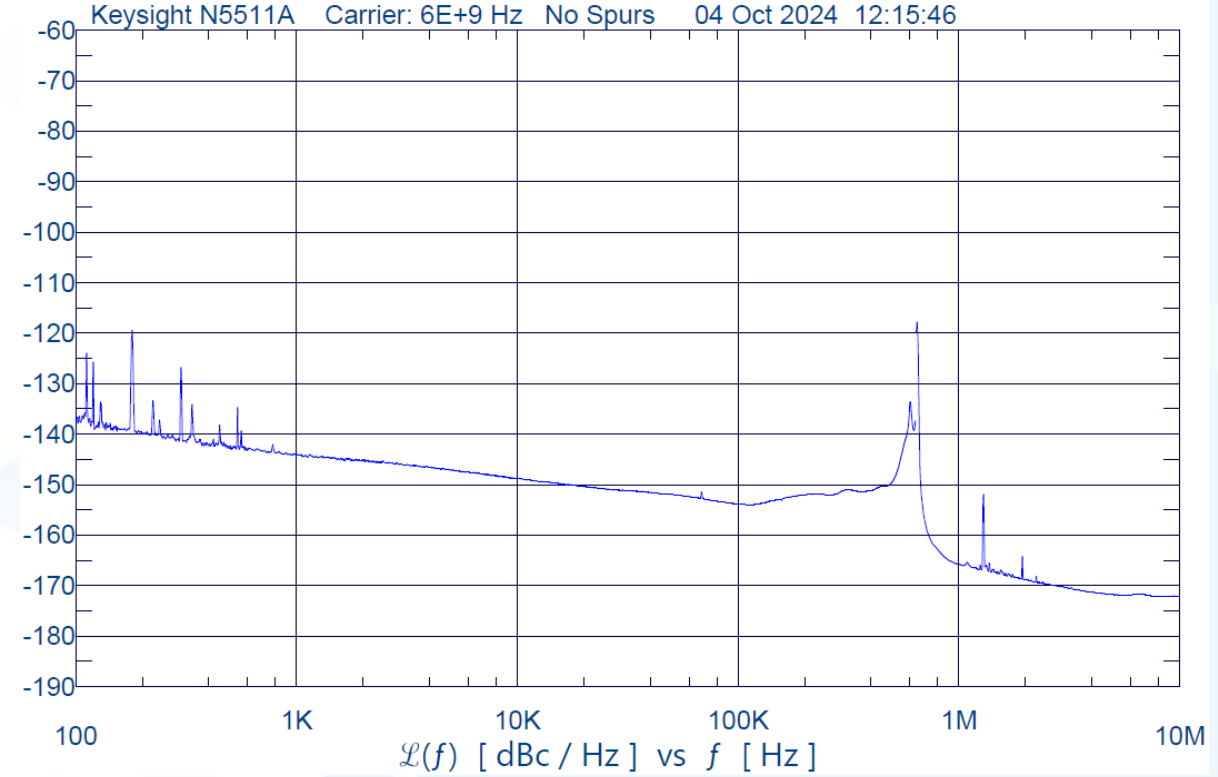

DC Power from LTM4702

▶ CCCC

# HMC8412 Residual Phase Noise, Pout = 6 dBm, Freq = 6 GHz

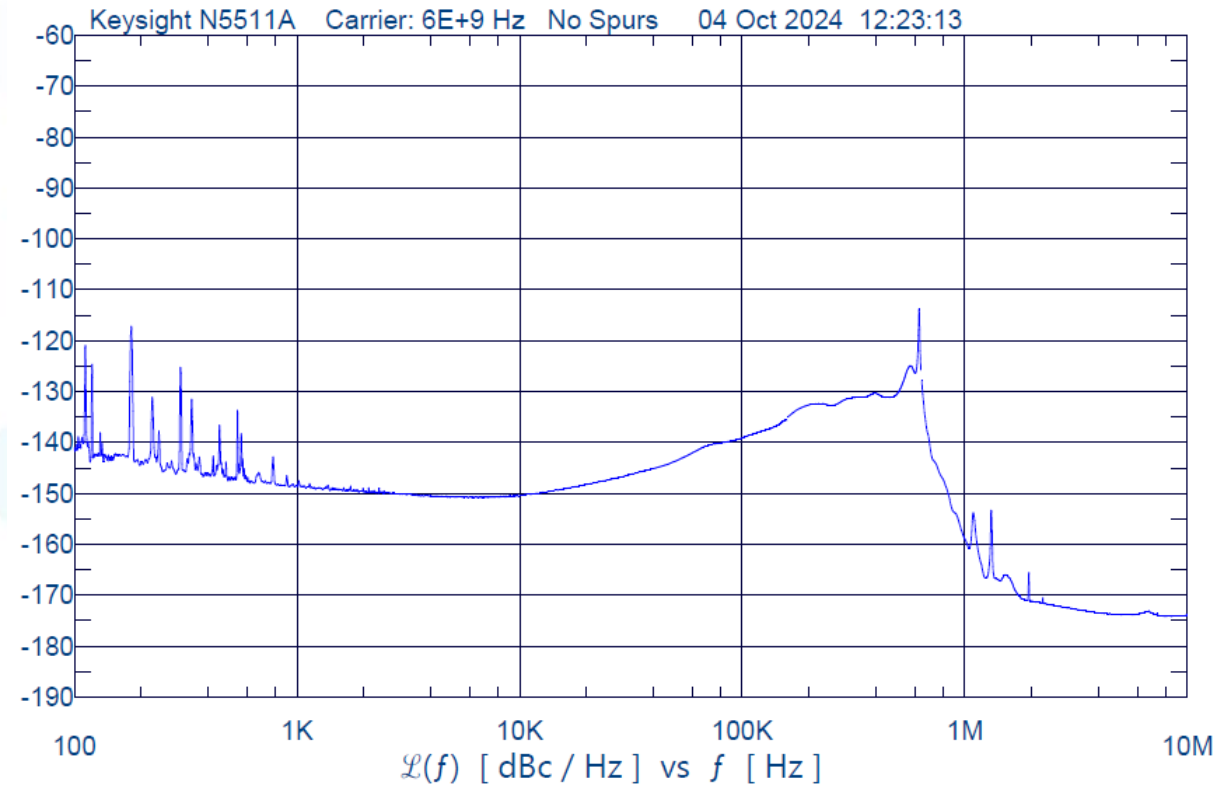
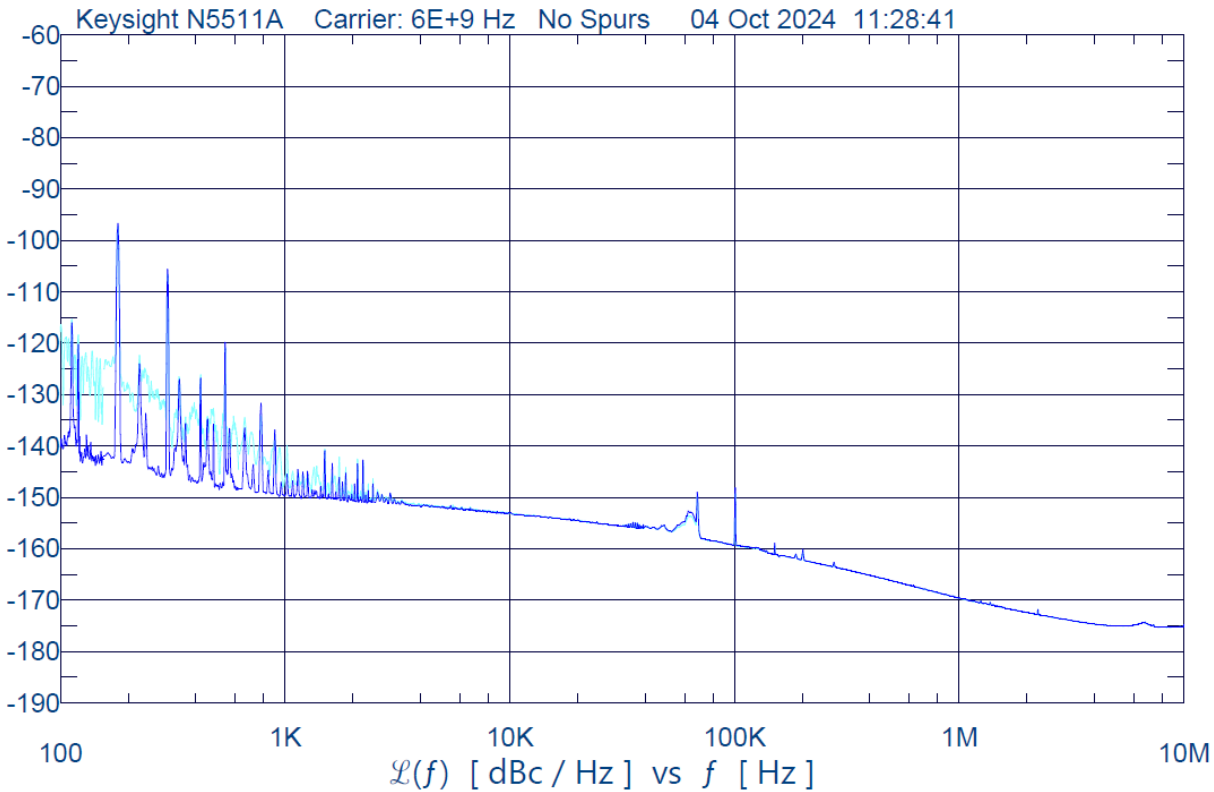

DC Power from Phase Noise Analyzer

DC Power from LTM4702

▶ CCCC

# Conclusions

- ▶ LTM402 Silent Switcher 3 performance appears identical to LT3042 LDO and Keysight Bench Supply
- ▶ Switching spur not visible in RF amplifier output spectrum but is visible on residual phase noise plot.
- ▶ EVM is an excellent metric for evaluating static performance of various power management solutions.
- ▶ Source EVM must be excellent ( $\ll 1\%$ )

# Using EVM to Assess the Quality of Power Management Circuits in RF Signal Chains

Eamon Nash – Analog Devices