



**ADI** Power

# Digital Power System Management

**µModule<sup>®</sup> Regulators | DC-to-DC Controllers & Converters | LDOs | Power System Managers | Sequencers | Supervisors**

## Take Control of Your Power Supplies

Accelerate characterization and optimization during prototyping and field operation with Analog Devices' digital power system management (DPSM) products, which are configured and monitored via a PMBus<sup>®</sup>/SMBus/I<sup>2</sup>C digital interface.

### Benefits

- Manage power topologies via digital telemetry & control
- Test complete power systems with LTpowerPlay<sup>®</sup>
- Reduced validation effort and time to market
- Autonomous operation—no software coding required
- Coordinate sequencing and fault management
- Increase power system reliability
- Optimize board energy consumption

### Features

- PMBus compliant commands over I<sup>2</sup>C/SMBus digital interface
- Digitally manage point-of-load (POL) power supplies
- Trim, margin, sequence, and supervise power rails
- Monitor voltages, current, power, energy, and temperature
- EEPROM options for customization
- Black box fault logging



For more information on  
Analog Devices Digital Power  
visit [analog.com/digitalpower](http://analog.com/digitalpower)

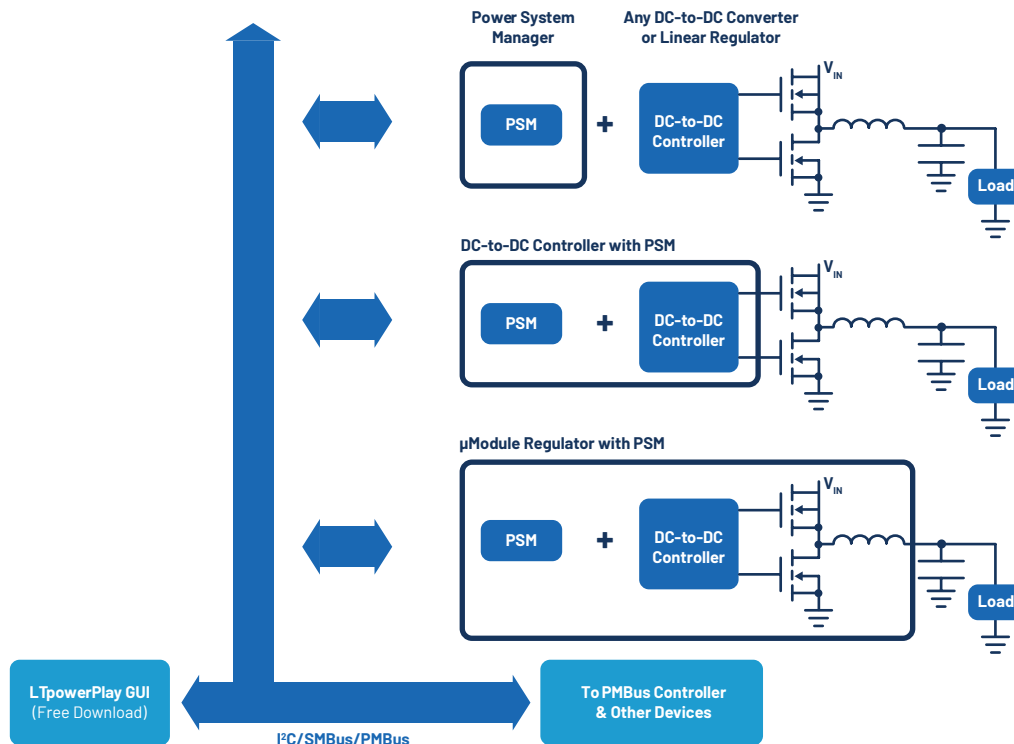

## Know Your Power Supply Health

Manage power supplies with digital interface-based control, telemetry, and black box fault recording of analog DC-to-DC power converters. Digital power solutions support on-the-fly adjustment of configuration parameters, remote supervision, and command of power system digital monitoring, and data logging of voltage, current, power, and temperature, as well as trimming, margining, sequencing, supervision, and fault logging/management of multiple point-of-load supplies.

## Optimize Your Power Solution

Optimize performance vs. energy consumed with power domains, load shedding, and tweaking of supply voltages. Improve reliability by precise control of power supplies over environmental conditions and coordinate sequencing and fault management.

## Discover Comprehensive Digital Power Options

With products ranging from power system managers to DC-to-DC controllers and fully integrated μModule regulators, design and manage power with ease using PMBus-compliant commands over an I<sup>2</sup>C/SMBus digital interface for varied power topologies for a wide range of power levels.

## Programmable 6-Channel Sequencer and Supervisors with EEPROM

Device	Sequencer/Supervisor	Comparator Outputs	Threshold Range	Threshold Accuracy	Power Supply	Package (mm x mm)
LTC2933	Supervisor	No	1 V to 13.9 V (1×) 0.2 V to 5.8 V (5×)	±1%	3.4 V to 13.9 V	5 × 4, 16-lead DFN, 16-lead SSOP
LTC2936	Supervisor	Yes	0.2 V to 5.8 V (6×)	±1%	3.13 V to 13.9 V	4 × 5, 24-lead QFN, 24-lead SSOP
LTC2937	Both	No	0.2 V to 6 V (6×)	±0.75%	2.9 V to 16.5 V	5 × 6, 28-lead QFN

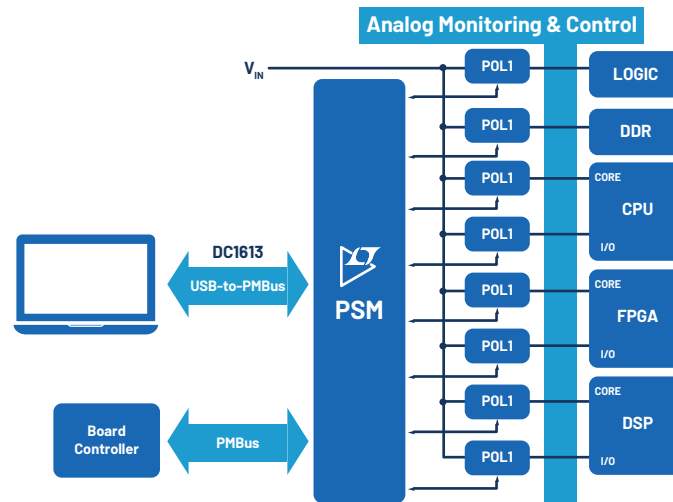

## PMBus Monitors: Precise Monitoring of Critical Parameters

- Manage any adjustable point-of-load power supply
- Read back voltage, current, power, energy, temperature, and faults
- Trim, margin, sequence, supervise, manage faults, monitor telemetry, and record fault logs

## PMBus Monitors

Device	Voltage Supply Channels Managed	Number of current sensed loads	Temp Sense		SMBus/ I <sup>2</sup> C	Digital Interface		EEPROM	Sequencing			Power Supply	Package (mm x mm)
			Internal	External		PMBus	DPSM		Time	Cascadable/ Stackable	Event		
ADM1266	17					•		•	•	•	3V to 15V	9 x 9, 64-lead LFCSP	
LTC2971	2	3			•	•	•	•			3.13V to 60V	7 x 7, 49-lead BGA	
LTC2972	2	3	•	•	•	•	•	•	•		3.13V to 15V	6 x 7, 44-lead QFN	
LTC2974	4	4	•	•	•	•	•	•	•		3.13V to 15V	9 x 9, 64-lead QFN	
LTC2975	4	5	•	•	•	•	•	•	•		3.13V to 15V	9 x 9, 64-lead QFN 7.5 x 6.25, 63-lead BGA	
LTC2977	8	4	•		•	•	•	•			3.13V to 15V	9 x 9, 64-lead QFN	
LTC2979	16	8	•		•	•	•	•			3.13V to 3.43V	12 x 12, 144-lead BGA	
LTC2980	16	8	•		•	•	•	•	•		3.13V to 15V	12 x 12, 144-lead BGA	
LTC2980-24	24	12	•		•	•	•	•	•		3.13V to 15V	8.1 x 16.9, 210-lead BGA	
LTM2987	16	8	•		•	•	•	•			3.13V to 15V	15 x 15, 144-lead BGA	
MAX34440	6		•	•		•			•	•	2.7V to 5.5V	6 x 6, 40-lead TQFN	
MAX34446	4	4	•	•		•					2.7 to 5.5V	6 x 6, 40-lead TQFN	
MAX34451	16	16	•	•		•			•	•	3V to 3.6V	7 x 7, 56-lead TQFN	
MAX34460A	12		•	•		•			•	•	3V to 3.6V	6 x 6, 48-lead TQFN	
MAX34461A	16		•	•		•			•	•	3V to 3.6V	6 x 6, 48-lead TQFN	

## Buck Regulators with Digital PSM: Precision Power Control Made Easy

- **Internal FETs for Higher Integration and Smaller Footprint**
- **Autonomous Voltage Management:**
- Control and supervise dozens of power rails with ease.
- **High-Accuracy Telemetry & Programming for Precise Configuration of:**
- Voltage and current
- Sequencing and operating frequency
- Margining, fault detection, and temperature
- **LTpowerPlay® Software Support:**
- Windows-based tool for intuitive configuration and interrogation of PSM devices.
- **Seamless System Integration:**
- Easily embedded into existing architectures for streamlined power system management.

### PMBus Buck Converter

Part Number	V <sub>in</sub> Range	Number of Outputs	V <sub>out</sub> Range (V)	I <sub>out</sub> Range (A)	Digital Interface			Number of Phases	Built in Memory	Software GUI	Package (mm x mm)
					PMBus	DPSM	AVSBus				
LT7182S	1.5 to 20	2	0.4 to 5.5	Dual 6 or Single 12	•	•		8	EEPROM	LTPowerPlay	5 x 7, 40-lead LQFN
LT7184S	1.5 to 16	2	0.4 to 5.5	Dual 9 or Single 18	•	•		8	EEPROM	LTPowerPlay	4 x 5, 36-lead LQFN
LT7170	1.5 to 16	1	0.4 to 5.5	20	•	•		1	NVM	LTPowerPlay	3.5 x 4, 24-lead LQFN
LT7171	1.5 to 16	1	0.4 to 5.5	20	•	•		4	NVM	LTPowerPlay	3.5 x 4, 30-lead LCC
LTC7131-1	4.5 to 20	1	0.5 to 4	25	•	•		2		LTPowerPlay	7.5 x 6.25, 63-lead BGA
LTC7132	4.5 to 20	2	0.5 to 5.5	Dual 25 or Single 50	•	•		6	EEPROM	LTPowerPlay	11.25 x 9, 140-lead BGA
LTC3815	2.25 to 5.5	1	0.4 to 4	6	•						4 x 6, 38-lead QFN
MAX20860A	5 to 16	1	0.4 to 5.8	60	•		•	2	NVM	Unified Power GUI	4.25 x 10, 36-lead LFCSP
MAX20840T	2.7 to 16	1	0.4 to 5.8	40	•			1		Unified Power GUI	4.3 x 6.55, 16-lead LFCSP
MAX20830	2.7 to 16	1	0.4 to 5.8	30	•			1		Unified Power GUI	4.3 x 6.55, 16-lead LFCSP
MAX20815	2.7 to 16	1	0.4 to 5.8	15	•			1		Unified Power GUI	6.55 x 4.3, 16-lead LFCSP
MAX20810	2.7 to 16	1	0.4 to 5.8	10	•			1		Unified Power GUI	4.3 x 6.5, 16-lead LFCSP
MAX20796	4.5 to 16	1	0.5 to 5.5	60	•			2	NVM	PowerTool GUI	4 x 10.5, 35-lead FC2QFN
MAX20710	4.5 to 16	1	0.6 to 5.5	10	•			1		PowerTool GUI	4.15 x 6, 15-lead LFCSP
MAX20734	4.5 to 16	1	0.6 to 5.5	40	•			1		PowerTool GUI	4.15 x 9, 15-lead LFCSP
MAX20730	4.5 to 16	1	0.6 to 5.5	25	•			1		PowerTool GUI	4.15 x 6, 15-lead LFCSP
MAX20743	4.5 to 16	1	0.6 to 5.5	35	•			1		PowerTool GUI	4.15 x 8, 15-lead LFCSP
LT7176	2.7-4V*	1	0.3 to 3.4	24	•	•		1	NVM	LTPowerPlay	3.5 x 4 LQFN
LT7176-1	2.7-4V*	1	0.3 to 3.4	24	•	•		2	NVM	LTPowerPlay	3.5 x 4 LQFN

\*1.5-4V with EXT<sub>VCC</sub>

## PMBus Controllers Deliver Precision Digital Power Management for Enhanced System Reliability and Efficiency

- Digital control, configuration, and status monitoring for power supplies and voltage regulators
- Fine-grained power control: output voltage setting, power sequencing, and environmental monitoring
- Robust fault handling and dynamic adjustments for improved reliability and energy efficiency

### PMBus Controllers

Part Number	Description	Number of Outputs	V <sub>in</sub> (Min)	V <sub>in</sub> (Max)	Output Current (typ)	Interface	Max Frequency (Hz)	Package (mm x mm)
MAX20816	Dual-Output Multiphase High-Current PWMVID and AVSBus Controller	2		3.6		AVSBus, PMBus, PWMVID		7 x 7, 56-lead LFCSP
MAX20855A	VR14 8-Phase, Dual-Output Voltage Regulator Chipset	2		3.6		PMBus, SVID		5 x 5, 40-lead FCLGA
LTC7883	Quad Output PolyPhase Step-Down DC/DC Voltage Mode Controller with Digital Power System Management	4	3	13.2	40	I2C/SMBus, PMBus, PSMBus	2.5MHz	9 x 7.5, 99-Lead BGA
MAX20754	Dual-Output, Configurable Multiphase Power-Supply Controller with PMBus Interface and Internal Buck Converter	2	4.5	16	150	PMBus	1MHz	7 x 7, 48-lead TQFN
LTC3888-1	Dual Loop 8-Phase Step-Down DC/DC Controller with Digital Power System Management	2	4.5	26.5	400	I2C/SMBus, PMBus, PSMBus		5 x 8, 52-lead QFN
LTC3888	Dual Loop 8-Phase Step-Down DC/DC Controller with Digital Power System Management	2	4.5	26.5	400	I2C/SMBus, PMBus, PSMBus, SPI	1MHz	5 x 8, 52-lead QFN
MAX16602	VR13.HC and AI Cores Dual-Output Voltage Regulator Chipset	2	4.5	16		I2C/SMBus, PMBus	800KHz	7 x 7, 56-lead LFCSP

### LDOs with PMBus for Digital Power Management

- Industry's first LDO with PMBus for DPSM
- Program limits, warnings, alerts and margining
- Supports high accuracy telemetry and fault reporting
- Ultra-low noise performance not affected by digital interface operation
- Fully supported by LTpowerPlay and LTspice software

### PMBus LDO Linear Regulator

Part Number	V <sub>in</sub> Range (V)	Number of Outputs	V <sub>out</sub> Range (V)	I <sub>out</sub> (A)	PSRR (dB)	Built in Memory	Noise (μVrms)	Package (mm x mm)
LT3074	0.6 to 5.5	1	0.1 to 5.5	3	55	No	1.2	3 x 4, 22-lead LQFN

## µModule Converter with PMBus Interface Streamline Digital Power System Management

- Enable real-time command and supervision of power conditions and consumption
- Digitally configurable power supply parameters reduce time-to-market and eliminate hardware-level design changes
- Simplify system characterization, optimization, and data mining across prototyping, deployment, and field operation
- Utilize digital I2C/SMBus interface & LTpowerPlay software for customization

### PMBus µModule Regulators

Part Number	V <sub>in</sub> Range (V)	Number of Outputs	V <sub>out</sub> Range (V)	I <sub>Out</sub> (A)	Built-in Memory	Package (mm x mm)
LTM4686B	2.375* to 5.75	2	0.5 to 3.6	Dual 14 or Single 28	Yes	16 x 11.9, 108-lead LGA
LTM4739	3 to 15	1	0.4 to 5.5	10	No	49-Ball CSP BGA
LTM4675	4.5 to 17	2	0.5 to 5.5	Dual 9 or Single 18	Yes	16 x 11.9, 108-lead BGA
LTM4686	4.5 to 17	2	0.5 to 3.6	Dual 10 or Single 20	Yes	16 x 11.9, 108-lead LGA
LTM4686-1	2.375* to 17	2	0.5 to 3.6	Dual 10 or Single 20	Yes	16 x 11.9, 108-lead LGA
LTM4676A	4.5 to 26.5	2	0.5 to 5.5	Dual 13 or Single 26	Yes	16 x 16, 144-lead BGA
LTM4677	4.5 to 16	2	0.5 to 1.8	Dual 18 or Single 36	Yes	16 x 16, 144-lead BGA
LTM4678	4.5 to 16	2	0.5 to 3.3	Dual 25 or Single 50	Yes	16 x 16, 144-lead BGA
LTM4680	4.5 to 16	2	0.5 to 3.3	Dual 30 or Single 60	Yes	16 x 16, 144-lead BGA
LTM4700	4.5 to 16	2	0.5 to 1.8	Dual 50 or Single 100	Yes	22 x 15, 330-lead BGA
LTM4673	4.5 to 15	4	0.6 to 3.3 (12A rails) 0.6 to 5.5 (5A rails)	Dual 12 or Single 24 and Dual 5 or Single 10	Yes	16 x 16, 361-lead BGA
LTM4681	4.5 to 16	4	0.5 to 3.3	Quad 31.25 to Single 125	Yes	22 x 15, 330-lead BGA
LTM4682	4.5 to 16	4	0.7 to 1.35	Quad 31.25 to Single 125	Yes	15 x 22, 330-lead BGA
LTM4683	4.5 to 14	4	0.3 to 0.7	Quad 31.25 to Single 125	Yes	15 x 22, 330-lead BGA
LTP8800-1A	45 to 65	1	0.5 to 1.1	150	Yes	22 x 24, 22-lead PCA
LTP8800-4A	45 to 65	1	0.5 to 1.1	200	Yes	22 x 24, 22-lead PCA
LTP8802A-1B	45 to 65	1	0.5 to 3.6	140	Yes	22 x 24, 22-lead PCA
LTP8803-1A	45 to 65	1	0.5 to 1.5	160	Yes	22 x 24, 22-lead PCA
LTM4664	30 to 58	2	0.5 to 1.5	Dual 25 or Single 50	Yes	16 x 16, 240-lead BGA
LTM4664A	30 to 58	2	0.5 to 1.2	Dual 30 or Single 60	Yes	16 x 16, 240-lead BGA

\*Requires external bias voltage

# Tools for Digital Power System Management

## Software Support

### LTpowerPlay

LTpowerPlay is a powerful and intuitive Windows®-based development environment used to configure and interrogate PSM devices. It can also be used in an offline mode (with no hardware present) in order to build a multichip configuration file that can be saved and reloaded at a later time. It is available as a free download at: [analog.com/LTpowerPlay](http://analog.com/LTpowerPlay).



## Hardware Support

A DC16313A USB-to-I<sup>2</sup>C/SMBus/PMBus controller (adapter) is used to interface any PSM demo board to a computer. Every PSM device comes with at least one specific demo board. Some PSM demo boards can be cascaded together for evaluating multiple rails.

To USB port of  
computer running  
LTpowerPlay

12-pin ribbon cable  
to PSM demo board



If needed, DC2086 adapts  
12-pin cable to 4-pin header

## Device Programming

PSM devices ship from Analog Devices with a default register configuration loaded in EEPROM. The options to ship with a customized, application-specific configuration developed during the prototyping phase are as follows:

- Analog Devices NVM Programming Service: This involves submitting the configuration file, then receiving a few custom programmed samples (First Articles) for verification and approval. Visit Analog Devices Express (ADX) at: [analog.com/programming](http://analog.com/programming).
- In-Circuit Programming: Use LTpowerPlay on a computer with a DC1613 USB-to-PMBus controller (adapter) to program PSM devices on circuit boards with pin headers accessing the PSM device.
- JTAG Programming: Use third-party programmers from Asset Intertech or JTAG Technologies to program PSM devices on circuit boards connected to JTAG scan chains without needing additional programmers or pin headers.



# Power Management Tools: Your Companion Across the Entire Power Design Journey

ADI Power Studio helps power engineers at every stage of their design process simplify complexity, validate designs early, and optimize architectures efficiently, enabling faster development cycles, reduced rework, and greater confidence in delivering power-dense systems to market.

Plan	»	Design	»	Simulate	»	Configure	»	Measure
System-Level Power Tree Creation		IC-Level Power Supply Design		Industry-Standard Simulation		Digital Power System Management		Evaluation and Power Supply Characterization
WEB-BASED <a href="#">ADI Power Studio™ Planner</a>		WEB-BASED <a href="#">ADI Power Studio™ Designer</a>		WINDOWS + macOS <a href="#">LTspice®</a>		WINDOWS <a href="#">LTpowerPlay®</a> <a href="#">ADI Power Studio™ Systemizer</a>		WINDOWS <a href="#">LTpowerAnalyzer™</a>
WINDOWS <a href="#">LTpowerPlanner®</a>		WINDOWS <a href="#">LTpowerCAD®</a>		WINDOWS <a href="#">OASIS™/SIMPLIS®</a>		<a href="#">Signal Chain Power</a>		



For more information on Analog Devices Digital Power visit [analog.com/digitalpower](http://analog.com/digitalpower)



Find more power components from Analog Devices at [analog.com/power](http://analog.com/power)

myAnalog is your access to the full [analog.com](http://analog.com) experience!  
Register now to enable your access.  
[my.analog.com](http://my.analog.com)



Engage with the ADI technology experts in our online support community.  
Ask your tough design questions, browse FAQs, or join a conversation.  
[ez.analog.com](http://ez.analog.com)



AHEAD OF WHAT'S POSSIBLE™

[analog.com](http://analog.com)

For regional headquarters, sales, and distributors or to contact customer service and technical support, visit [analog.com/contact](http://analog.com/contact).  
©2026 Analog Devices, Inc. All rights reserved. Trademarks and registered trademarks are the property of their respective owners.