

TMCM-1636 TMCL™ Firmware Manual

Firmware Version V1.13 | Document Revision V1.05 • 2022-MAY-30

The TMCM-1636 is a single axis servo drive for 3-phase BLDC and DC motors with up to ca. 1000W running at +24V or +48V. It offers a CAN interface with either TMCL or CANopen protocol for communication. While in stop mode a UART interface is available to configure the module via the TMCL protocol. The TMCM-1636 supports various position feedback options: incremental quadrature encoder, digital HALL sensor, absolute SPI- and SSI-based encoder. Customization of firmware and hardware is possible.

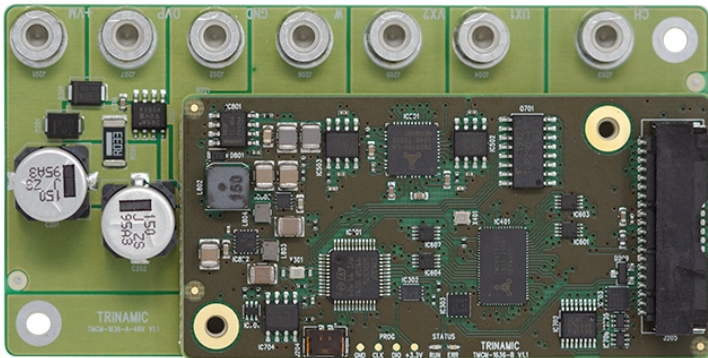

Features

- Servo Drive for BLDC and DC Motor
- +24V and +48V Supply Version
- Up to 1000W continuous
- Up to 60A RMS phase current max.
- CAN interface
- Incremental encoder
- Digital HALL sensor
- Absolute SPI & SSI-based encoder support
- Various GPIOs
- Motor brake control and overvoltage protection

Applications

- Robotics
- Laboratory Automation
- Manufacturing
- Factory Automation
- Servo Drives
- Motorized Tables and Chairs
- Industrial BLDC & DC Motor Drives

Simplified Block Diagram

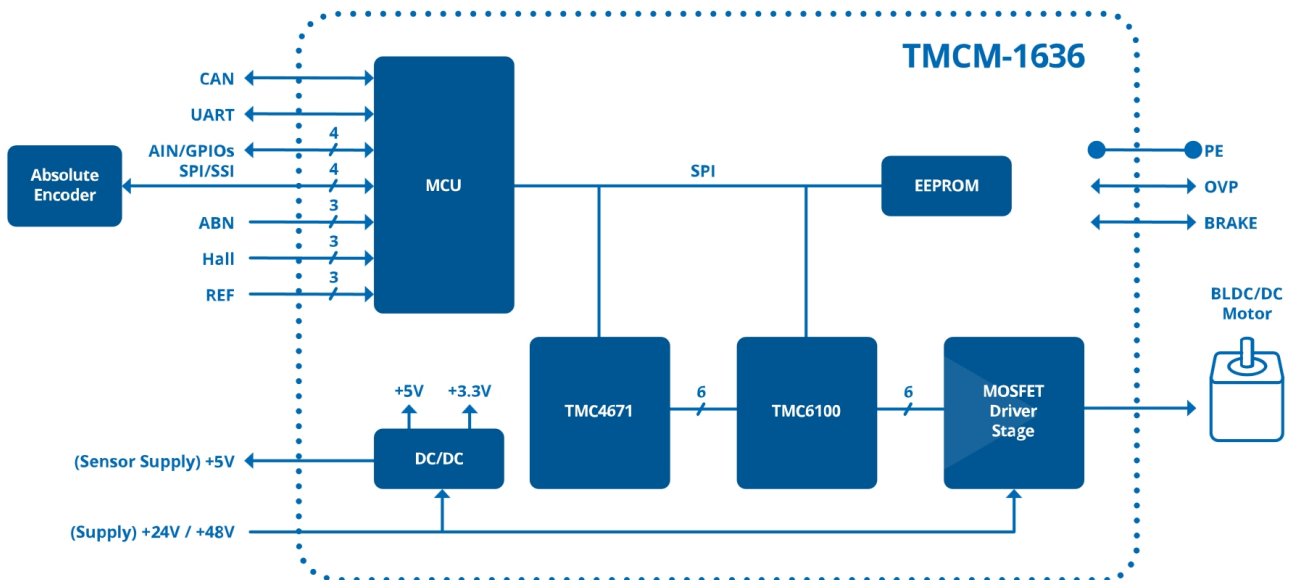

Contents

1	First Steps with TMCL	3
1.1	Basic Setup	3
1.2	Using the TMCL Direct Mode	3
1.3	Testing with a simple TMCL Program	3
2	TMCL and the TMCL-IDE — An Introduction	5
2.1	Binary Command Format	5
2.1.1	Checksum Calculation	6
2.2	Reply Format	7
2.2.1	Status Codes	7
2.3	Standalone Applications	8
2.4	TMCL Command Overview	9
2.5	TMCL Commands by Subject	10
2.5.1	Motion Commands	10
2.5.2	Parameter Commands	10
2.5.3	Branch Commands	11
2.5.4	I/O Port Commands	11
2.5.5	Calculation Commands	12
2.6	Detailed TMCL Command Descriptions	13
2.6.1	ROR (Rotate Right)	13
2.6.2	ROL (Rotate Left)	14
2.6.3	MST (Motor Stop)	15
2.6.4	MVP (Move to Position)	16
2.6.5	SAP (Set Axis Parameter)	18
2.6.6	GAP (Get Axis Parameter)	19
2.6.7	STAP (Store Axis Parameter)	20
2.6.8	RSAP (Restore Axis Parameter)	21
2.6.9	SGP (Set Global Parameter)	22
2.6.10	GGP (Get Global Parameter)	24
2.6.11	STGP (Store Global Parameter)	25
2.6.12	RSGP (Restore Global Parameter)	26
2.6.13	SIO (Set Output)	27
2.6.14	GIO (Get Input)	29
2.6.15	CALC (Calculate)	32
2.6.16	COMP (Compare)	34
2.6.17	JC (Jump conditional)	35
2.6.18	JA (Jump always)	37
2.6.19	CSUB (Call Subroutine)	38
2.6.20	RSUB (Return from Subroutine)	39
2.6.21	WAIT (Wait for an Event to occur)	40
2.6.22	STOP (Stop TMCL Program Execution – End of TMCL Program)	42
2.6.23	CALCX (Calculate using the X Register)	43
2.6.24	AAP (Accu to Axis Parameter)	45
2.6.25	AGP (Accu to Global Parameter)	46
2.6.26	CLE (Clear Error Flags)	47
2.6.27	Customer specific Command Extensions (UF0... UF7 – User Functions)	49
2.6.28	TMCL Control Commands	50
3	Axis Parameters	52
4	Global Parameters	60
4.1	Bank 0	60

4.2 Bank 2	62
5 Getting Started	63
5.1 Absolute Encoders	63
5.1.1 ATM20	63
5.1.2 ATM23	64
5.2 External Brake Control	65
6 TMCL Programming Techniques and Structure	67
6.1 Initialization	67
6.2 Main Loop	67
6.3 Using Symbolic Constants	67
6.4 Using Variables	68
6.5 Using Subroutines	69
6.6 Combining Direct Mode and Standalone Mode	69
6.7 Make the TMCL Program start automatically	70
7 Figures Index	71
8 Tables Index	72
9 Supplemental Directives	73
9.1 Producer Information	73
9.2 Copyright	73
9.3 Trademark Designations and Symbols	73
9.4 Target User	73
9.5 Disclaimer: Life Support Systems	73
9.6 Disclaimer: Intended Use	73
9.7 Collateral Documents & Tools	74
10 Revision History	75
10.1 Firmware Revision	75
10.2 Document Revision	75

1 First Steps with TMCL

In this chapter you can find some hints for your first steps with the TMCM-1636 and TMCL. You may skip this chapter if you are already familiar with TMCL and the TMCL-IDE.

Things that you will need

- Your TMCM-1636 Module.
- A power supply (24V DC) for your TMCM-1636 Module.
- A CAN adapter.
- The TMCL-IDE 3.x already installed on your PC

1.1 Basic Setup

First of all, you will need a PC with Windows (at least Windows 7) and the TMCL-IDE 3.x installed on it. If you do not have the TMCL-IDE installed on your PC then please download it from the TMCL-IDE product page of Trinamic's website (www.trinamic.com/support/software/) and install it on your PC.

Please also ensure that your TMCM-1636 is properly connected to your power supply. Please see the TMCM-1636 hardware manual for instructions on how to do this. **Do not connect or disconnect the motor to or from the module while the module is powered!** Then, please start up the TMCL-IDE. Afterwards you can connect your TMCM-1636. Just connect the module via CAN and switch on the power supply.

1.2 Using the TMCL Direct Mode

At first try to use some TMCL commands in direct mode. In the TMCL-IDE a tree view showing the TMCM-1636 and all tools available for it is displayed. Click on the Direct Mode entry of the tool tree. Now, the Direct Mode tool will pop up.

In the Direct Mode tool you can choose a TMCL command, enter the necessary parameters and execute the command. For example, choose the command ROL (rotate left). Then choose the appropriate motor (motor 0 if your motor is connected to the motor 0 connector). Now, enter the desired speed. Try entering 500 rpm as the value and then click the Execute button. The motor will now run. Choose the MST (motor stop) command and click Execute again to stop the motor.

Next you can try changing some settings (also called axis parameters) using the SAP command in direct mode. Choose the SAP command. Then choose the parameter type and the motor number. Last, enter the desired value and click execute to execute the command which then changes the desired parameter. Please see chapter 3 for a complete list of all axis parameters.

1.3 Testing with a simple TMCL Program

Now, test the TMCL stand alone mode with a simple TMCL program. To type in, assemble and download the program, you will need the TMCL creator. This is also a tool that can be found in the tool tree of the TMCL-IDE. Click the TMCL creator entry to open the TMCL creator. In the TMCL creator, type in the following little TMCL program:

```
1   SAP 53, 0, 1000    //set position reached distance
2   SAP 54, 0, 500    //set position reached velocity [rpm]
3   SAP 74, 0, 500    //set position P
```

```
5   SAP 44, 0, 10000 //set acceleration [rpm/s]
7   SAP 15, 0, 3     //switch to encoder mode
9   ROR 0, 200      //rotate motor
11  WAIT TICKS, 0, 300
13  // clear position counter on next encoder-N-Channel event
15  SAP 107, 0, 1    //set clear on null
17  SAP 108, 0, 1    //set clear once
19  WAIT TICKS, 0, 300
21  PositionTest:
    MVP ABS, 0, 0
    WAIT POS, 0, 0
    MVP ABS, 0, 655360
    WAIT POS, 0, 0
    JA PositionTest
```

After you have done that, take the following steps:

1. Click the Assemble icon (or choose Assemble from the TMCL menu) in the TMCL creator to assemble the program.
2. Click the Download icon (or choose Download from the TMCL menu) in the TMCL creator to download the program to the module.
3. Click the Run icon (or choose Run from the TMCL menu) in the TMCL creator to run the program on the module.

Also try out the debugging functions in the TMCL creator:

1. Click on the Bug icon to start the debugger.
2. Click the Animate button to see the single steps of the program.
3. You can at any time pause the program, set or reset breakpoints and resume program execution.
4. To end the debug mode click the Bug icon again.

2 TMCL and the TMCL-IDE — An Introduction

As with most TRINAMIC modules the software running on the microprocessor of the TMCM-1636 consists of two parts, a boot loader and the firmware itself. Whereas the boot loader is installed during production and testing at TRINAMIC and remains untouched throughout the whole lifetime, the firmware can be updated by the user. New versions can be downloaded free of charge from the TRINAMIC website (<http://www.trinamic.com>).

The TMCM-1636 supports TMCL direct mode (binary commands). It also implements standalone TMCL program execution. This makes it possible to write TMCL programs using the TMCL-IDE and store them in the memory of the module.

In direct mode the TMCL communication over RS-232, RS-485, CAN, and USB follows a strict master/slave relationship. That is, a host computer (e.g. PC/PLC) acting as the interface bus master will send a command to the TMCM-1636. The TMCL interpreter on the module will then interpret this command, do the initialization of the motion controller, read inputs and write outputs or whatever is necessary according to the specified command. As soon as this step has been done, the module will send a reply back over the interface to the bus master. Only then should the master transfer the next command.

Normally, the module will just switch to transmission and occupy the bus for a reply, otherwise it will stay in receive mode. It will not send any data over the interface without receiving a command first. This way, any collision on the bus will be avoided when there are more than two nodes connected to a single bus. The Trinamic Motion Control Language (TMCL) provides a set of structured motion control commands. Every motion control command can be given by a host computer or can be stored in an EEPROM on the TMCM module to form programs that run standalone on the module. For this purpose there are not only motion control commands but also commands to control the program structure (like conditional jumps, compare and calculating).

Every command has a binary representation and a mnemonic. The binary format is used to send commands from the host to a module in direct mode, whereas the mnemonic format is used for easy usage of the commands when developing standalone TMCL applications using the TMCL-IDE (IDE means Integrated Development Environment).

There is also a set of configuration variables for the axis and for global parameters which allow individual configuration of nearly every function of a module. This manual gives a detailed description of all TMCL commands and their usage.

2.1 Binary Command Format

Every command has a mnemonic and a binary representation. When commands are sent from a host to a module, the binary format has to be used. Every command consists of a one-byte command field, a one-byte type field, a one-byte motor/bank field and a four-byte value field. So the binary representation of a command always has seven bytes. When a command is to be sent via RS-232, RS-485, RS-422 or USB interface, it has to be enclosed by an address byte at the beginning and a checksum byte at the end. In these cases it consists of nine bytes.

The binary command format with RS-232, RS-485, RS-422 and USB is as follows:

TMCL Command Format	
Bytes	Meaning
1	Module address
1	Command number
1	Type number
1	Motor or Bank number
4	Value (MSB first!)
1	Checksum

Table 1: TMCL Command Format

Info

The checksum is calculated by accumulating all the other bytes using an 8-bit addition.

Note

When using the CAN interface, leave out the address byte and the checksum byte. With CAN, the CAN-ID is used as the module address and the checksum is not needed because CAN bus uses hardware CRC checking.

2.1.1 Checksum Calculation

As mentioned above, the checksum is calculated by adding up all bytes (including the module address byte) using 8-bit addition. Here are two examples which show how to do this:

Checksum calculation in C:

```

1 unsigned char i, Checksum;
  unsigned char Command[9];
3
  //Set the Command array to the desired command
5 Checksum = Command[0];
  for(i=1; i<8; i++)
7     Checksum+=Command[i];
9
  Command[8]=Checksum; //insert checksum as last byte of the command
  //Now, send it to the module

```

Checksum calculation in Delphi:

```

var
2   i, Checksum: byte;
   Command: array[0..8] of byte;
4
   //Set the Command array to the desired command
6
   //Calculate the Checksum:
8   Checksum:=Command[0];
   for i:=1 to 7 do Checksum:=Checksum+Command[i];
10  Command[8]:=Checksum;
   //Now, send the Command array (9 bytes) to the module

```

2.2 Reply Format

Every time a command has been sent to a module, the module sends a reply. The reply format with RS-232, RS-485, RS-422 and USB is as follows:

TMCL Reply Format	
Bytes	Meaning
1	Reply address
1	Module address
1	Status (e.g. 100 means no error)
1	Command number
4	Value (MSB first!)
1	Checksum

Table 2: TMCL Reply Format

i Info

The checksum is also calculated by adding up all the other bytes using an 8-bit addition. Do not send the next command before having received the reply!

Note

When using CAN interface, the reply does not contain an address byte and a checksum byte. With CAN, the CAN-ID is used as the reply address and the checksum is not needed because the CAN bus uses hardware CRC checking.

2.2.1 Status Codes

The reply contains a status code. The status code can have one of the following values:

TMCL Status Codes	
Code	Meaning
100	Successfully executed, no error
101	Command loaded into TMCL program EEPROM
1	Wrong checksum
2	Invalid command
3	Wrong type
4	Invalid value
5	Configuration EEPROM locked
6	Command not available

Table 3: TMCL Status Codes

2.3 Standalone Applications

The module is equipped with a TMCL memory for storing TMCL applications. You can use the TMCL-IDE for developing standalone TMCL applications. You can download a program into the EEPROM and afterwards it will run on the module. The TMCL-IDE contains an editor and the TMCL assembler where the commands can be entered using their mnemonic format. They will be assembled automatically into their binary representations. Afterwards this code can be downloaded into the module to be executed there.

2.4 TMCL Command Overview

This section gives a short overview of all TMCL commands.

Overview of all TMCL Commands			
Command	Number	Parameter	Description
ROR	1	<motor number>, <velocity>	Rotate right with specified velocity
ROL	2	<motor number>, <velocity>	Rotate left with specified velocity
MST	3	<motor number>	Stop motor movement
MVP	4	ABS REL, <motor number>, <position offset>	Move to position (absolute or relative)
SAP	5	<parameter>, <motor number>, <value>	Set axis parameter (motion control specific settings)
GAP	6	<parameter>, <motor number>	Get axis parameter (read out motion control specific settings)
STAP	7	<parameter>, <motor number>, <value>	Store axis parameter (store motion control specific settings)
RSAP	8	<parameter>, <motor number>	Restore axis parameter (restore motion control specific settings)
SGP	9	<parameter>, <bank number>, <value>	Set global parameter (module specific settings e.g. communication settings or TMCL user variables)
GGP	10	<parameter>, <bank number>	Get global parameter (read out module specific settings e.g. communication settings or TMCL user variables)
STGP	11	<parameter>, <bank number>	Store global parameter (TMCL user variables only)
RSGP	12	<parameter>, <bank number>	Restore global parameter (TMCL user variables only)
SIO	14	<port number>, <bank number>, <value>	Set digital output to specified value
GIO	15	<port number>, <bank number>	Get value of analog/digital input
CALC	19	<operation>, <value>	Aithmetical operation between accumulator and direct value
COMP	20	<value>	Compare accumulator with value
JC	21	<condition>, <jump address>	Jump conditional
JA	22	<jump address>	Jump absolute
CSUB	23	<subroutine address>	Call subroutine
RSUB	24		Return from subroutine
WAIT	27	<condition>, <motor number>, <ticks>	Wait with further program execution

Command	Number	Parameter	Description
STOP	28		Stop program execution
CALCX	33	<operation>	Arithmetical operation between accumulator and X-register
AAP	34	<parameter>, <motor number>	Accumulator to axis parameter
AGP	35	<parameter>, <bank number>	Accumulator to global parameter
CLE	36	<flag>	Clear an error flag

Table 4: Overview of all TMCL Commands

2.5 TMCL Commands by Subject

2.5.1 Motion Commands

These commands control the motion of the motor. They are the most important commands and can be used in direct mode or in standalone mode.

Motion Commands		
Mnemonic	Command number	Meaning
ROL	2	Rotate left
ROR	1	Rotate right
MVP	4	Move to position
MST	3	Motor stop

Table 5: Motion Commands

2.5.2 Parameter Commands

These commands are used to set, read and store axis parameters or global parameters. Axis parameters can be set independently for each axis, whereas global parameters control the behavior of the module itself. These commands can also be used in direct mode and in standalone mode.

Parameter Commands		
Mnemonic	Command number	Meaning
SAP	5	Set axis parameter
GAP	6	Get axis parameter
STAP	7	Store axis parameter
RSAP	8	Restore axis parameter
SGP	9	Set global parameter
GGP	10	Get global parameter
STGP	11	Store global parameter
RSGP	12	Restore global parameter

Table 6: Parameter Commands

2.5.3 Branch Commands

These commands are used to control the program flow (loops, conditions, jumps etc.). Using them in direct mode does not make sense. They are intended for standalone mode only.

Branch Commands		
Mnemonic	Command number	Meaning
JA	22	Jump always
JC	21	Jump conditional
COMP	20	Compare accumulator with constant value
CSUB	23	Call subroutine
RSUB	24	Return from subroutine
WAIT	27	Wait for a specified event
STOP	28	End of a TMCL program

Table 7: Branch Commands

2.5.4 I/O Port Commands

These commands control the external I/O ports and can be used in direct mode as well as in standalone mode.

I/O Port Commands		
Mnemonic	Command number	Meaning
SIO	14	Set output
GIO	15	Get input

Table 8: I/O Port Commands

2.5.5 Calculation Commands

These commands are intended to be used for calculations within TMCL applications. Although they could also be used in direct mode it does not make much sense to do so.

Calculation Commands		
Mnemonic	Command number	Meaning
CALC	19	Calculate using the accumulator and a constant value
CALCX	33	Calculate using the accumulator and the X register
AAP	34	Copy accumulator to an axis parameter
AGP	35	Copy accumulator to a global parameter

Table 9: Calculation Commands

For calculating purposes there is an accumulator (also called accu or A register) and an X register. When executed in a TMCL program (in standalone mode), all TMCL commands that read a value store the result in the accumulator. The X register can be used as an additional memory when doing calculations. It can be loaded from the accumulator.

When a command that reads a value is executed in direct mode the accumulator will not be affected. This means that while a TMCL program is running on the module (standalone mode), a host can still send commands like GAP and GGP to the module (e.g. to query the actual position of the motor) without affecting the flow of the TMCL program running on the module.

2.6 Detailed TMCL Command Descriptions

The module specific commands are explained in more detail on the following pages. They are listed according to their command number.

2.6.1 ROR (Rotate Right)

The motor is instructed to rotate with a specified velocity in right direction (increasing the position counter). The velocity is given in rounds per minute (rpm).

Internal function: Velocity mode is selected. Then, the velocity value is transferred to the target velocity.

Related commands: ROL, MST, SAP, GAP.

Mnemonic: ROR <axis>, <velocity>

Binary Representation			
Instruction	Type	Motor/Bank	Value
1	0	0	-2147483648...2147583647

Reply in Direct Mode	
Status	Value
100 - OK	don't care

Example

Rotate right motor 0, velocity 500.

Mnemonic: ROR 0, 500.

Binary Form of ROR 0, 500	
Field	Value
Target address	01 _h
Instruction number	01 _h
Type	00 _h
Motor/Bank	00 _h
Value (Byte 3)	00 _h
Value (Byte 2)	00 _h
Value (Byte 1)	01 _h
Value (Byte 0)	F4 _h
Checksum	F7 _h

2.6.2 ROL (Rotate Left)

The motor is instructed to rotate with a specified velocity in left direction (decreasing the position counter). The velocity is given in rounds per minute (rpm).

Internal function: Velocity mode is selected. Then, the velocity value is transferred to the target velocity.

Related commands: ROR, MST, SAP, GAP.

Mnemonic: ROL <axis>, <velocity>

Binary Representation			
Instruction	Type	Motor/Bank	Value
2	0	0	-2147483648...2147583647

Reply in Direct Mode	
Status	Value
100 - OK	don't care

Example

Rotate left motor 0, velocity 500.

Mnemonic: ROL 0, 500.

Binary Form of ROL 0, 500	
Field	Value
Target address	01 _h
Instruction number	02 _h
Type	00 _h
Motor/Bank	00 _h
Value (Byte 3)	00 _h
Value (Byte 2)	00 _h
Value (Byte 1)	01 _h
Value (Byte 0)	F4 _h
Checksum	F8 _h

2.6.3 MST (Motor Stop)

The MST command stops the motor using a soft stop.

Internal function: The velocity mode is selected. Then, the target velocity is set to zero.

Related commands: ROR, ROL, SAP, GAP.

Mnemonic: MST <axis>

Binary Representation			
Instruction	Type	Motor/Bank	Value
3	0	0	0

Reply in Direct Mode	
Status	Value
100 - OK	don't care

Example

Stop motor 0.

Mnemonic: MST 0.

Binary Form of MST 0	
Field	Value
Target address	01 _h
Instruction number	03 _h
Type	00 _h
Motor/Bank	00 _h
Value (Byte 3)	00 _h
Value (Byte 2)	00 _h
Value (Byte 1)	00 _h
Value (Byte 0)	00 _h
Checksum	04 _h

2.6.4 MVP (Move to Position)

With this command the motor will be instructed to move to a specified relative or absolute position. It will use the acceleration/deceleration ramp and the positioning speed programmed into the unit. This command is non-blocking - that is, a reply will be sent immediately after command interpretation and initialization of the motion controller. Further commands may follow without waiting for the motor reaching its end position. The maximum velocity and acceleration as well as other ramp parameters are defined by the appropriate axis parameters. For a list of these parameters please refer to section 3.

The range of the MVP command is 32 bit signed (-2147483648...2147483647). Positioning can be interrupted using MST, ROL or ROR commands.

Two operation types are available:

- Moving to an absolute position in the range from -2147483648...2147483647 ($-2^{31} \dots 2^{31} - 1$).
- Starting a relative movement by means of an offset to the actual position. In this case, the new resulting position value must not exceed the above mentioned limits, too.

Note

The distance between the actual position and the new position must not be more than 2147483647 ($2^{31} - 1$) position steps. Otherwise the motor will run in the opposite direction in order to take the shorter distance (caused by 32 bit overflow).

Internal function: Position mode is selected and the new position value is transferred to axis parameter #50 (target position).

Related commands: SAP, GAP, MST.

Mnemonic: MVP <ABS|REL>, <axis>, <position|offset>

Binary Representation			
Instruction	Type	Motor/Bank	Value
4	0 - ABS - absolute	0	<position>
	1 - REL - relative	0	<offset>

Reply in Direct Mode	
Status	Value
100 - OK	don't care

Example

Move motor 0 to position 90000.

Mnemonic: MVP ABS, 0, 90000

Binary Form of MVP ABS, 0, 90000	
Field	Value
Target address	01 _h
Instruction number	04 _h
Type	00 _h
Motor/Bank	00 _h
Value (Byte 3)	00 _h
Value (Byte 2)	01 _h
Value (Byte 1)	5F _h
Value (Byte 0)	90 _h
Checksum	F5 _h

Example

Move motor 0 from current position 10000 steps backward.

Mnemonic: MVP REL, 0, -10000

Binary Form of MVP REL, 0, -10000	
Field	Value
Target address	01 _h
Instruction number	04 _h
Type	01 _h
Motor/Bank	00 _h
Value (Byte 3)	FF _h
Value (Byte 2)	FF _h
Value (Byte 1)	D8 _h
Value (Byte 0)	F0 _h
Checksum	CC _h

2.6.5 SAP (Set Axis Parameter)

With this command most of the motion control parameters of the module can be specified. The settings will be stored in SRAM and therefore are volatile. That is, information will be lost after power off.

i Info

For a table with parameters and values which can be used together with this command please refer to section 3.

Internal function: The specified value is written to the axis parameter specified by the parameter number.

Related commands: GAP, AAP.

Mnemonic: SAP <parameter number>, <axis>, <value>

Binary representation

Binary Representation			
Instruction	Type	Motor/Bank	Value
5	see chapter 3	0	<value>

Reply in Direct Mode	
Status	Value
100 - OK	don't care

Example Set the maximum velocity for motor 0 to 200rpm.

Mnemonic: SAP 43, 0, 200.

Binary Form of SAP 43, 0, 200	
Field	Value
Target address	01 _h
Instruction number	05 _h
Type	2B _h
Motor/Bank	00 _h
Value (Byte 3)	00 _h
Value (Byte 2)	00 _h
Value (Byte 1)	00 _h
Value (Byte 0)	C8 _h
Checksum	F9 _h

2.6.6 GAP (Get Axis Parameter)

Most motion / driver related parameters of the TMC-1636 can be adjusted using e.g. the SAP command. With the GAP parameter they can be read out. In standalone mode the requested value is also transferred to the accumulator register for further processing purposes (such as conditional jumps). In direct mode the value read is only output in the value field of the reply, without affecting the accumulator.

i Info

For a table with parameters and values that can be used together with this command please refer to section 3.

Internal function: The specified value gets copied to the accumulator.

Related commands: SAP, AAP.

Mnemonic: GAP <parameter number>, <axis>

Binary Representation			
Instruction	Type	Motor/Bank	Value
6	see chapter 3	0	<value>

Reply in Direct Mode	
Status	Value
100 - OK	value read by this command

Example

Get the actual position of motor 0.

Mnemonic: GAP 52, 0.

Binary Form of GAP 52, 0	
Field	Value
Target address	01 _h
Instruction number	06 _h
Type	34 _h
Motor/Bank	00 _h
Value (Byte 3)	00 _h
Value (Byte 2)	00 _h
Value (Byte 1)	00 _h
Value (Byte 0)	00 _h
Checksum	3B _h

2.6.7 STAP (Store Axis Parameter)

This command is used to store TMCL axis parameters permanently in the EEPROM of the module. This command is mainly needed to store the default configuration of the module. The contents of the user variables can either be automatically or manually restored at power on.

Info

For a table with parameters and values which can be used together with this command please refer to section 3.

Internal function: The axis parameter specified by the type and bank number will be stored in the EEPROM.

Related commands: SAP, AAP, GAP, RSAP.

Mnemonic: STAP <parameter number>, <bank>

Binary Representation			
Instruction	Type	Motor/Bank	Value
7	see chapter 3	0	0 (don't care)

Reply in Direct Mode	
Status	Value
100 - OK	0 (don't care)

Example

Store axis parameter #6 of motor #0.

Mnemonic: STAP 6, 0.

Binary Form of STAP 6, 0	
Field	Value
Target address	01 _h
Instruction number	07 _h
Type	06 _h
Motor/Bank	00 _h
Value (Byte 3)	00 _h
Value (Byte 2)	00 _h
Value (Byte 1)	00 _h
Value (Byte 0)	00 _h
Checksum	0E _h

2.6.8 RSAP (Restore Axis Parameter)

With this command the contents of an axis parameter can be restored from the EEPROM. By default, all axis parameters are automatically restored after power up. An axis parameter that has been changed before can be reset to the stored value by this instruction.

Info

For a table with parameters and values which can be used together with this command please refer to section 3.

Internal function: The axis parameter specified by the type and bank number will be restored from the EEPROM.

Related commands: SAP, AAP, GAP, RSAP.

Mnemonic: RSAP <parameter number>, <bank>

Binary Representation			
Instruction	Type	Motor/Bank	Value
8	see chapter 3	0	0 (don't care)

Reply in Direct Mode	
Status	Value
100 - OK	0 (don't care)

Example

Restore axis parameter #6 of motor #0.

Mnemonic: RSAP 6, 0.

Binary Form of RSAP 6, 0	
Field	Value
Target address	01 _h
Instruction number	08 _h
Type	06 _h
Motor/Bank	00 _h
Value (Byte 3)	00 _h
Value (Byte 2)	00 _h
Value (Byte 1)	00 _h
Value (Byte 0)	00 _h
Checksum	0F _h

2.6.9 SGP (Set Global Parameter)

With this command most of the module specific parameters not directly related to motion control can be specified and the TMCL user variables can be changed. Global parameters are related to the host interface, peripherals or application specific variables. The different groups of these parameters are organized in banks to allow a larger total number for future products. Currently, bank 0 is used for global parameters, and bank 2 is used for user variables. Bank 3 is used for interrupt configuration.

All module settings in bank 0 will automatically be stored in non-volatile memory (EEPROM).

Info

For a table with parameters and values which can be used together with this command please refer to section 4.

Internal function: The specified value will be copied to the global parameter specified by the type and bank number. Most parameters of bank 0 will automatically be stored in non-volatile memory.

Related commands: GGP, AGP.

Mnemonic: SGP <parameter number>, <bank>, <value>

Binary Representation			
Instruction	Type	Motor/Bank	Value
9	see chapter 4	0/2/3	<value>

Reply in Direct Mode	
Status	Value
100 - OK	don't care

Example

Set the serial address of the device to 3.

Mnemonic: SGP 66, 0, 3.

Binary Form of SGP 66, 0, 3	
Field	Value
Target address	01 _h
Instruction number	09 _h
Type	42 _h
Motor/Bank	00 _h
Value (Byte 3)	00 _h
Value (Byte 2)	00 _h
Value (Byte 1)	00 _h
Value (Byte 0)	03 _h
Checksum	4F _h

2.6.10 GGP (Get Global Parameter)

All global parameters can be read with this function. Global parameters are related to the host interface, peripherals or application specific variables. The different groups of these parameters are organized in banks to allow a larger total number for future products. Currently, bank 0 is used for global parameters, and bank 2 is used for user variables. Bank 3 is used for interrupt configuration.

i Info

For a table with parameters and values which can be used together with this command please refer to section 4.

Internal function: The global parameter specified by the type and bank number will be copied to the accumulator register.

Related commands: SGP, AGP.

Mnemonic: GGP <parameter number>, <bank>

Binary Representation			
Instruction	Type	Motor/Bank	Value
10	see chapter 4	0/2/3	0 (don't care)

Reply in Direct Mode	
Status	Value
100 - OK	value read by this command

Example

Get the serial address of the device.

Mnemonic: GGP 66, 0.

Binary Form of GGP 66, 0	
Field	Value
Target address	01 _h
Instruction number	0A _h
Type	42 _h
Motor/Bank	00 _h
Value (Byte 3)	00 _h
Value (Byte 2)	00 _h
Value (Byte 1)	00 _h
Value (Byte 0)	00 _h
Checksum	4D _h

2.6.11 STGP (Store Global Parameter)

This command is used to store TMCL global parameters permanently in the EEPROM of the module. This command is mainly needed to store the TMCL user variables (located in bank 2) in the EEPROM of the module, as most other global parameters (located in bank 0) are stored automatically when being modified. The contents of the user variables can either be automatically or manually restored at power on.

Info

For a table with parameters and values which can be used together with this command please refer to section 4.2.

Internal function: The global parameter specified by the type and bank number will be stored in the EEPROM.

Related commands: SGP, AGP, GGP, RSGP.

Mnemonic: STGP <parameter number>, <bank>

Binary Representation			
Instruction	Type	Motor/Bank	Value
11	see chapter 4.2	2	0 (don't care)

Reply in Direct Mode	
Status	Value
100 - OK	0 (don't care)

Example

Store user variable #42.

Mnemonic: STGP 42, 2.

Binary Form of STGP 42, 2	
Field	Value
Target address	01 _h
Instruction number	0B _h
Type	2A _h
Motor/Bank	02 _h
Value (Byte 3)	00 _h
Value (Byte 2)	00 _h
Value (Byte 1)	00 _h
Value (Byte 0)	00 _h
Checksum	38 _h

2.6.12 RSGP (Restore Global Parameter)

With this command the contents of a TMCL user variable can be restored from the EEPROM. By default, all user variables are automatically restored after power up. A user variable that has been changed before can be reset to the stored value by this instruction.

i Info

For a table with parameters and values which can be used together with this command please refer to section 4.2.

Internal function: The global parameter specified by the type and bank number will be restored from the EEPROM.

Related commands: SGP, AGP, GGP, STGP.

Mnemonic: RSGP <parameter number>, <bank>

Binary Representation			
Instruction	Type	Motor/Bank	Value
12	see chapter 4.2	2	0 (don't care)

Reply in Direct Mode	
Status	Value
100 - OK	0 (don't care)

Example

Restore user variable #42.

Mnemonic: RSGP 42, 2.

Binary Form of RSGP 42, 2	
Field	Value
Target address	01 _h
Instruction number	0C _h
Type	2A _h
Motor/Bank	02 _h
Value (Byte 3)	00 _h
Value (Byte 2)	00 _h
Value (Byte 1)	00 _h
Value (Byte 0)	00 _h
Checksum	39 _h

2.6.13 SIO (Set Output)

This command sets the states of the general purpose digital outputs.

Internal function: The state of the output line specified by the type parameter is set according to the value passed to this command.

Related commands: GIO.

Mnemonic: SIO <port number>, <bank number>, <value>

Binary Representation			
Instruction	Type	Motor/Bank	Value
14	<port number>	<bank number> (2)	0/1

Reply in Direct Mode	
Status	Value
100 - OK	0 (don't care)

Example

Set output 0 (bank 2) to high.

Mnemonic: SIO 0, 2, 1.

Binary Form of SIO 0, 2, 1	
Field	Value
Target address	01 _h
Instruction number	0E _h
Type	00 _h
Motor/Bank	02 _h
Value (Byte 3)	00 _h
Value (Byte 2)	00 _h
Value (Byte 1)	00 _h
Value (Byte 0)	01 _h
Checksum	12 _h

Bank 2 – Digital Outputs

The following output lines can be set by the SIO commands) using bank 2.

Digital Outputs in Bank 2			
Port	Description	Command	Range
0 - GPO_0	Digital output 0	SIO 0, 2, <value>	0/1
1 - GPO_1	Digital output 1	SIO 1, 2, <value>	0/1

2.6.14 GIO (Get Input)

With this command the status of the available general purpose outputs of the module can be read. The function reads a digital or an analog input port. Digital lines will read as 0 or 1, while the ADC channels deliver their 12 bit result in the range of 0...4095. In standalone mode the requested value is copied to the accumulator register for further processing purposes such as conditional jumps. In direct mode the value is only output in the value field of the reply, without affecting the accumulator. The actual status of a digital output line can also be read.

Internal function: The state of the i/o line specified by the type parameter and the bank parameter is read.

Related commands: SIO.

Mnemonic: GIO <port number>, <bank number>

Binary Representation			
Instruction	Type	Motor/Bank	Value
15	<port number>	<bank number> (0/1/2)	0 (don't care)

Reply in Direct Mode	
Status	Value
100 - OK	status of the port

Example

Get the value of ADC channel 0.

Mnemonic: GIO 0, 1.

Binary Form of GIO 0, 1	
Field	Value
Target address	01 _h
Instruction number	0F _h
Type	00 _h
Motor/Bank	01 _h
Value (Byte 3)	00 _h
Value (Byte 2)	00 _h
Value (Byte 1)	00 _h
Value (Byte 0)	00 _h
Checksum	11 _h

Reply (Status=no error, Value=302)	
Field	Value
Host address	02 _h
Target address	01 _h
Status	64 _h
Instruction	0F _h
Value (Byte 3)	00 _h
Value (Byte 2)	00 _h
Value (Byte 1)	01 _h
Value (Byte 0)	2E _h
Checksum	A5 _h

Bank 0 - Digital Inputs

The analog input lines can be read as digital or analog inputs at the same time. The digital input states can be accessed in bank 0.

Digital Inputs in Bank 0			
Port	Description	Command	Range
0 - GPI_0	Digital input 0	GIO 0, 0	0/1
1 - GPI_1	Digital input 1	GIO 1, 0	0/1
2 - GPI_2	Digital input 2	GIO 2, 0	0/1
3 - GPI_3	Digital input 3	GIO 3, 0	0/1

Bank 1 - Analog Inputs

The analog input lines can be read back as digital or analog inputs at the same time. The analog values can be accessed in bank 1.

Analog Inputs in Bank 1			
Port	Description	Command	Range
0 - AIN_0	Analog input 0	GIO 0, 1	0...4095
1 - AIN_1	Analog input 1	GIO 1, 1	0...4095
2 - ADC_VM	Analog input 0	GIO 2, 1	0...65535
3 - ADC_TEMP	Analog input 1	GIO 3, 1	0...65535

Bank 2 - States of the Digital Outputs

The states of the output lines (that have been set by SIO commands) can be read back using bank 2.

Digital Outputs in Bank 2			
Port	Description	Command	Range
0 - GPO_0	Digital output 0	GIO 0, 2, <value>	0/1
1 - GPO_1	Digital output 1	GIO 1, 2, <value>	0/1

2.6.15 CALC (Calculate)

A value in the accumulator variable, previously read by a function such as GAP (get axis parameter) can be modified with this instruction. Nine different arithmetic functions can be chosen and one constant operand value must be specified. The result is written back to the accumulator, for further processing like comparisons or data transfer. *This command is mainly intended for use in standalone mode.*

Related commands: CALCX, COMP, AAP, AGP, GAP, GGP, GIO.

Mnemonic: CALC <operation>, <operand>

Binary representation

Binary Representation			
Instruction	Type	Motor/Bank	Value
19	0 ADD – add to accumulator 1 SUB – subtract from accumulator 2 MUL – multiply accumulator by 3 DIV – divide accumulator by 4 MOD – modulo divide accumulator by 5 AND – logical and accumulator with 6 OR – logical or accumulator with 7 XOR – logical exor accumulator with 8 NOT – logical invert accumulator 9 LOAD – load operand into accumulator	0 (don't care)	<operand>

Reply in Direct Mode	
Status	Value
100 - OK	the operand (don't care)

Example

Multiply accumulator by -5000.

Mnemonic: CALC MUL, -5000

Binary Form of CALC MUL, -5000	
Field	Value
Target address	01 _h
Instruction number	13 _h
Type	02 _h
Motor/Bank	00 _h
Value (Byte 3)	FF _h
Value (Byte 2)	FF _h
Value (Byte 1)	EC _h
Value (Byte 0)	78 _h
Checksum	78 _h

Reply (Status=no error, value=-5000:	
Field	Value
Host address	02 _h
Target address	01 _h
Status	64 _h
Instruction	13 _h
Value (Byte 3)	FF _h
Value (Byte 2)	FF _h
Value (Byte 1)	EC _h
Value (Byte 0)	78 _h
Checksum	DC _h

2.6.16 COMP (Compare)

The specified number is compared to the value in the accumulator register. The result of the comparison can for example be used by the conditional jump (JC) instruction. *This command is intended for use in standalone operation only.*

Internal function: The accumulator register is compared with the specified value. The internal arithmetic status flags are set according to the result of the comparison. These can then control e.g. a conditional jump.

Related commands: JC, GAP, GGP, GIO, CALC, CALCX.

Mnemonic: COMP <operand>

Binary Representation			
Instruction	Type	Motor/Bank	Value
20	0 (don't care)	0 (don't care)	<operand>

Example

Jump to the address given by the label when the position of motor #0 is greater than or equal to 1000.

```

1 GAP 52, 0 //get actual position of motor 0
  COMP 1000 //compare actual value with 1000
3 JC GE, Label //jump to Label if greater or equal to 1000
    
```

Binary Form of COMP 1000	
Field	Value
Target address	01 _h
Instruction number	14 _h
Type	00 _h
Motor/Bank	00 _h
Value (Byte 3)	00 _h
Value (Byte 2)	00 _h
Value (Byte 1)	03 _h
Value (Byte 0)	E8 _h
Checksum	00 _h

2.6.17 JC (Jump conditional)

The JC instruction enables a conditional jump to a fixed address in the TMCL program memory, if the specified condition is met. The conditions refer to the result of a preceding comparison. Please refer to COMP instruction for examples. *This command is intended for standalone operation only.*

Internal function: The TMCL program counter is set to the value passed to this command if the status flags are in the appropriate states.

Related commands: JA, COMP, WAIT, CLE.

Mnemonic: JC <condition>, <label>

Binary Representation			
Instruction	Type	Motor/Bank	Value
21	0 ZE - zero	0 (don't care)	<jump address>
	1 NZ - not zero		
	2 EQ - equal		
	3 NE - not equal		
	4 GT - greater		
	5 GE - greater/equal		
	6 LT - lower		
	7 LE - lower/equal		
	8 ETO - time out error		
	9 EAL - external alarm		
	10 EDV - deviation error		
	11 EPO - position error		

Example

Jump to the address given by the label when the position of motor #0 is greater than or equal to 1000.

```

1 GAP 52, 0 //get actual position of motor 0
  COMP 1000 //compare actual value with 1000
3 JC GE, Label //jump to Label if greater or equal to 1000
  ...
5 Label: ROL 0, 1000
    
```

Binary form of JC GE, Label assuming Label at address 10	
Field	Value
Target address	01 _h
Instruction number	15 _h
Type	05 _h
Motor/Bank	00 _h
Value (Byte 3)	00 _h
Value (Byte 2)	00 _h
Value (Byte 1)	00 _h
Value (Byte 0)	0A _h
Checksum	25 _h

2.6.18 JA (Jump always)

Jump to a fixed address in the TMCL program memory. *This command is intended for standalone operation only.*

Internal function: The TMCL program counter is set to the value passed to this command.

Related commands: JC, WAIT, CSUB.

Mnemonic: JA <label>

Binary Representation			
Instruction	Type	Motor/Bank	Value
22	0 (don't care)	0 (don't care)	<jump address>

Example

An infinite loop in TMCL:

```

1 Loop :
  MVP ABS , 0 , 51200
3  WAIT POS , 0 , 0
  MVP ABS , 0 , 0
5  WAIT POS , 0 , 0
  JA Loop
    
```

Binary form of the JA Loop command when the label Loop is at address 10:

Binary Form of JA Loop (assuming Loop at address 10)	
Field	Value
Target address	01 _h
Instruction number	16 _h
Type	00 _h
Motor/Bank	00 _h
Value (Byte 3)	00 _h
Value (Byte 2)	00 _h
Value (Byte 1)	00 _h
Value (Byte 0)	0A _h
Checksum	21 _h

2.6.19 CSUB (Call Subroutine)

This function calls a subroutine in the TMCL program memory. *It is intended for standalone operation only.*

Internal function: the actual TMCL program counter value is saved to an internal stack, afterwards overwritten with the passed value. The number of entries in the internal stack is limited to 8. This also limits nesting of subroutine calls to 8. The command will be ignored if there is no more stack space left.

Related commands: RSUB, JA.

Mnemonic: CSUB <label>

Binary Representation			
Instruction	Type	Motor/Bank	Value
23	0 (don't care)	0 (don't care)	<subroutine address>

Example

Call a subroutine:

```

Loop :
2   MVP ABS , 0 , 10000
   CSUB SubW //Save program counter and jump to label SubW
4   MVP ABS , 0 , 0
   CSUB SubW //Save program counter and jump to label SubW
6   JA Loop

8 SubW :
   WAIT POS , 0 , 0
10  WAIT TICKS , 0 , 50
   RSUB //Continue with the command following the CSUB command
    
```

Binary form of CSUB SubW (assuming SubW at address 100)	
Field	Value
Target address	01 _h
Instruction number	17 _h
Type	00 _h
Motor/Bank	00 _h
Value (Byte 3)	00 _h
Value (Byte 2)	00 _h
Value (Byte 1)	00 _h
Value (Byte 0)	64 _h
Checksum	7C _h

2.6.20 RSUB (Return from Subroutine)

Return from a subroutine to the command after the CSUB command. *This command is intended for use in standalone mode only.*

Internal function: the TMCL program counter is set to the last value saved on the stack. The command will be ignored if the stack is empty.

Related commands: CSUB.

Mnemonic: RSUB

Binary Representation			
Instruction	Type	Motor/Bank	Value
24	0 (don't care)	0 (don't care)	0 (don't care)

Example

Please see the CSUB example (section 2.6.19).

Binary form:

Binary Form of RSUB	
Field	Value
Target address	01 _h
Instruction number	18 _h
Type	00 _h
Motor/Bank	00 _h
Value (Byte 3)	00 _h
Value (Byte 2)	00 _h
Value (Byte 1)	00 _h
Value (Byte 0)	00 _h
Checksum	19 _h

2.6.21 WAIT (Wait for an Event to occur)

This instruction interrupts the execution of the TMCL program until the specified condition is met. *This command is intended for standalone operation only.*

There are five different wait conditions that can be used:

- TICKS: Wait until the number of timer ticks specified by the <ticks> parameter has been reached.
- POS: Wait until the target position of the motor specified by the <motor> parameter has been reached. An optional timeout value (0 for no timeout) must be specified by the <ticks> parameter.
- REFSW: Wait until the reference switch of the motor specified by the <motor> parameter has been triggered. An optional timeout value (0 for no timeout) must be specified by the <ticks> parameter.
- LIMSW: Wait until a limit switch of the motor specified by the <motor> parameter has been triggered. An optional timeout value (0 for no timeout) must be specified by the <ticks> parameter.

Special case for the <ticks> parameter: When this parameter is set to -1 the contents of the accumulator register will be taken for this value. So for example WAIT TICKS, 0, -1 will wait as long as specified by the value store in the accumulator. *The accumulator must not contain a negative value when using this option.*

The timeout flag (ETO) will be set after a timeout limit has been reached. You can then use a JC ETO command to check for such errors or clear the error using the CLE command.

Internal function: the TMCL program counter will be held at the address of this WAIT command until the condition is met or the timeout has expired.

Related commands: JC, CLE.

Mnemonic: WAIT <condition>, <motor number>, <ticks>

Binary Representation			
Instruction	Type	Motor/Bank	Value
27	0 TICKS – timer ticks	0 (don't care)	<no. of ticks to wait ¹ >
	1 POS – target position reached	<motor number>	<no. of ticks for timeout ¹ > 0 for no timeout
	2 REFSW – reference switch	<motor number>	<no. of ticks for timeout ¹ > 0 for no timeout
	3 LIMSW – limit switch	<motor number>	<no. of ticks for timeout ¹ > 0 for no timeout

Example

Wait for motor 0 to reach its target position, without timeout.

Mnemonic: WAIT POS, 0, 0

¹ one tick is 10 milliseconds

Binary Form of WAIT POS, 0, 0	
Field	Value
Target address	01 _h
Instruction number	1B _h
Type	01 _h
Motor/Bank	00 _h
Value (Byte 3)	00 _h
Value (Byte 2)	00 _h
Value (Byte 1)	00 _h
Value (Byte 0)	00 _h
Checksum	1D _h

2.6.22 STOP (Stop TMCL Program Execution – End of TMCL Program)

This command stops the execution of a TMCL program. *It is intended for use in standalone operation only.*

Internal function: Execution of a TMCL program in standalone mode will be stopped.

Related commands: none.

Mnemonic: STOP

Binary Representation			
Instruction	Type	Motor/Bank	Value
28	0 (don't care)	0 (don't care)	0 (don't care)

Example

Mnemonic: STOP

Binary Form of STOP	
Field	Value
Target address	01 _h
Instruction number	1C _h
Type	00 _h
Motor/Bank	00 _h
Value (Byte 3)	00 _h
Value (Byte 2)	00 _h
Value (Byte 1)	00 _h
Value (Byte 0)	00 _h
Checksum	1D _h

2.6.23 CALCX (Calculate using the X Register)

This instruction is very similar to CALC, but the second operand comes from the X register. The X register can be loaded with the LOAD or the SWAP type of this instruction. The result is written back to the accumulator for further processing like comparisons or data transfer. *This command is mainly intended for use in standalone mode.*

Related commands: CALC, COMP, JC, AAP, AGP, GAP, GGP, GIO.

Mnemonic: CALCX <operation>

Binary Representation			
Instruction	Type	Motor/Bank	Value
33	0 ADD – add X register to accumulator	0 (don't care)	0 (don't care)
	1 SUB – subtract X register from accumulator		
	2 MUL – multiply accumulator by X register		
	3 DIV – divide accumulator by X register		
	4 MOD – modulo divide accumulator by X register		
	5 AND – logical and accumulator with X register		
	6 OR – logical or accumulator with X register		
	7 XOR – logical exor accumulator with X register		
	8 NOT – logical invert X register		
	9 LOAD – copy accumulator to X register		
	10 SWAP – swap accumulator and X register		

Reply in Direct Mode	
Status	Value
100 - OK	don't care

Example

Multiply accumulator and X register.

Mnemonic: CALCX MUL

Binary Form of CALCX MUL	
Field	Value
Target address	01 _h
Instruction number	21 _h
Type	02 _h
Motor/Bank	00 _h
Value (Byte 3)	00 _h
Value (Byte 2)	00 _h
Value (Byte 1)	00 _h
Value (Byte 0)	00 _h
Checksum	24 _h

2.6.24 AAP (Accu to Axis Parameter)

The content of the accumulator register is transferred to the specified axis parameter. For practical usage, the accumulator has to be loaded e.g. by a preceding GAP instruction. The accumulator may have been modified by the CALC or CALCX (calculate) instruction. *This command is mainly intended for use in standalone mode.*

Info

For a table with parameters and values which can be used together with this command please refer to section 3.

Related commands: AGP, SAP, GAP, SGP, GGP, GIO, CALC, CALCX.

Mnemonic: AAP <parameter number>, <motor number>

Binary Representation			
Instruction	Type	Motor/Bank	Value
34	see chapter 3	0	<value>

Reply in Direct Mode	
Status	Value
100 - OK	don't care

Example

Position motor #0 by a potentiometer connected to analog input #0:

```

1 Start:
    GIO 0,1      //get value of analog input line 0
3    CALC MUL , 4 //multiply by 4
    AAP 50,0    //transfer result to target position of motor 0
5    JA Start   //jump back to start
    
```

Binary Form of AAP 50, 0	
Field	Value
Target address	01 _h
Instruction number	22 _h
Type	32 _h
Motor/Bank	00 _h
Value (Byte 3)	00 _h
Value (Byte 2)	00 _h
Value (Byte 1)	00 _h
Value (Byte 0)	00 _h
Checksum	55 _h

2.6.25 AGP (Accu to Global Parameter)

The content of the accumulator register is transferred to the specified global parameter. For practical usage, the accumulator has to be loaded e.g. by a preceding GAP instruction. The accumulator may have been modified by the CALC or CALCX (calculate) instruction. *This command is mainly intended for use in standalone mode.*

Info

For an overview of parameter and bank indices that can be used with this command please see section 4.

Related commands: AAP, SGP, GGP, SAP, GAP, GIO.

Mnemonic: AGP <parameter number>, <bank number>

Binary Representation			
Instruction	Type	Motor/Bank	Value
35	<parameter number>	0/2/3 <bank number>	0 (don't care)

Reply in Direct Mode	
Status	Value
100 - OK	don't care

Example

Copy accumulator to user variable #42:

Mnemonic: AGP 42, 2

Binary Form of AGP 42, 2	
Field	Value
Target address	01 _h
Instruction number	23 _h
Type	2A _h
Motor/Bank	02 _h
Value (Byte 3)	00 _h
Value (Byte 2)	00 _h
Value (Byte 1)	00 _h
Value (Byte 0)	00 _h
Checksum	50 _h

2.6.26 CLE (Clear Error Flags)

This command clears the internal error flags. It is mainly intended for use in standalone mode. The following error flags can be cleared by this command (determined by the <flag> parameter):

- ALL: clear all error flags.
- ETO: clear the timeout flag.
- EAL: clear the external alarm flag.
- EDV: clear the deviation flag.
- EPO: clear the position error flag.

Related commands: JC, WAIT.

Mnemonic: CLE <flags>

Binary Representation			
Instruction	Type	Motor/Bank	Value
36	0 ALL – all flags 1 – (ETO) timeout flag 2 – (EAL) alarm flag 3 – (EDV) deviation flag 4 – (EPO) position flag 5 – (ESD) shutdown flag	0 (don't care)	0 (don't care)

Reply in Direct Mode	
Status	Value
100 - OK	don't care

Example

Reset the timeout flag.

Mnemonic: CLE ETO

Binary Form of CLE ETO	
Field	Value
Target address	01 _h
Instruction number	24 _h
Type	01 _h
Motor/Bank	00 _h
Value (Byte 3)	00 _h
Value (Byte 2)	00 _h
Value (Byte 1)	00 _h
Value (Byte 0)	00 _h
Checksum	26 _h

2.6.27 Customer specific Command Extensions (UF0...UF7 – User Functions)

These commands are used for customer specific extensions of TMCL. They will be implemented in C by Trinamic. Please contact the sales department of Trinamic Motion Control GmbH & Co KG if you need a customized TMCL firmware.

Related commands: none.

Mnemonic: UF0...UF7

Binary Representation			
Instruction	Type	Motor/Bank	Value
64...71	<user defined>	0 <user defined>	0 <user defined>

Reply in Direct Mode	
Status	Value
100 - OK	user defined

2.6.28 TMCL Control Commands

There is a set of TMCL commands which are called TMCL control commands. These commands can only be used in direct mode and not in a standalone program. For this reason they only have opcodes, but no mnemonics. Most of these commands are only used by the TMCL-IDE (in order to implement e.g. the debugging functions in the TMCL creator). Some of them are also interesting for use in custom host applications, for example to start a TMCL routine on a module, when combining direct mode and standalone mode (please see also section 6.6. The following table lists all TMCL control commands.

The motor/bank parameter is not used by any of these functions and thus is not listed in the table. It should always be set to 0 with these commands.

TMCL Control Commands			
Instruction	Description	Type	Value
128 – stop application	stop a running TMCL application	0 (don't care)	0 (don't care)
129 – run application	start or continue TMCL program execution	0 – from current address 1 – from specific address	0 (don't care) starting address
130 – step application	execute only the next TMCL command	0 (don't care)	0 (don't care)
131 – reset application	Stop a running TMCL program. Reset program counter and stack pointer to zero. Reset accumulator and X register to zero. Reset all flags.	0 (don't care)	0 (don't care)
132 – enter download mode	All following commands (except control commands) are not executed but stored in the TMCL memory.	0 (don't care)	start address for download
133 – exit download mode	End the download mode. All following commands are executed normally again.	0 (don't care)	0 (don't care)
134 – read program memory	Return contents of the specified program memory location (special reply format).	0 (don't care)	address of memory location

Instruction	Description	Type	Value
135 – get application status	Return information about the current status, depending on the type field.	0 - return mode, wait flag, memory pointer 1 - return mode, wait flag, program counter 2 - return accumulator 3 - return X register	0 (don't care)
136 – get firmware version	Return firmware version in string format (special reply) or binary format).	0 - string format 1 - binary format	0 (don't care)
137 – restore factory settings	Reset all settings in the EEPROM to their factory defaults. This command does not send a reply.	0 (don't care)	set to 1234
255 – software reset	Restart the CPU of the module (like a power cycle). The reply of this command might not always get through.	0 (don't care)	set to 1234

Table 10: TMCL Control Commands

Especially the commands 128, 129, 131, 136 and 255 are interesting for use in custom host applications. The other control commands are mainly being used by the TMCL-IDE.

3 Axis Parameters

Most motor controller features of the TMCM-1636 module are controlled by axis parameters. Axis parameters can be modified or read using SAP, GAP and AAP commands. Some axis parameters can also be stored to or restored from the EEPROM using STAP and RSAP commands. This chapter describes all axis parameters that can be used on the TMCM-1636 module.

There are different parameter access types, like read only or read/write. Table 11 shows the different parameter access types used in the axis parameter tables.

Meaning of the Letters in the Access Column		
Access type	Command	Description
R	GAP	Parameter readable
W	SAP, AAP	Parameter writable
E	STAP, RSAP	Parameter can be stored in the EEPROM

Table 11: Meaning of the Letters in the Access Column

Axis 0 Parameters of the TMCM-1636 Module					
Number	Axis Parameter	Description	Range [Units]	Default	Access
0	adc_I0_raw	Raw adc measurement of the phase_A shunt	0 ... 65535	32767	R
1	adc_I1_raw	Raw adc measurement of the phase_B shunt	0 ... 65535	32767	R
2	adc_I0	Calculated current measurement for phase_A shunt and used offset	-32768 ... 32767	0	R
3	adc_I1	Calculated current measurement for phase_B shunt and used offset	-32768 ... 32767	0	R
4	adc_I2	Calculated current of phase_C from phase_A and phase_B measurements	-32768 ... 32767	0	R
5	adc_I0_offset	Manually set/get the dual-shunt phase_A offset.	0 ... 65535	33000	RWE
6	adc_I1_offset	Manually set/get the dual-shunt phase_B offset.	0 ... 65535	33000	RWE
10	motor pole pairs	Number of motor poles.	1 ... 255	4	RWE
11	max current	Max. allowed absolute motor current. *This value can be temporarily exceeded marginal due to the operation of the current regulator.	0 ... 60000 [mA]	4000	RWE

Number	Axis Parameter	Description	Range [Units]	Default	Access
12	open loop current	Motor current for controlled commutation. This parameter is used in commutation mode 1.	0 ... 60000 [mA]	2000	RWE
13	motor direction	Set motor direction. 0 - Rotate clockwise. 1 - Rotate counterclockwise.	0 ... 1	1	RWE
14	motor type	Select your motor type. 0 - No motor 1 - Single phase DC 3 - Three phase BLDC	0 ... 3	3	RWE
15	commutation mode	Select a commutation mode that fits best to your motor's sensors. 0 - disabled 1 - open loop 2 - digital hall 3 - ABN encoder 4 - absolute encoder	0 ... 4	0	RWE
16	open loop commutation angle	Actual controlled angle value.	-32768 ... 32767	0	R
17	encoder commutation angle	Actual encoder angle value.	-32768 ... 32767	0	R
18	digital hall commutation angle	Actual digital hall angle value.	-32768 ... 32767	0	R
19	absolute encoder commutation angle	Actual absolute encoder angle value.	-32768 ... 32767	0	R
25	position sensor selection	Feedback source for the position PI regulator. 0 - same as commutation 1 - ABN encoder 2 - absolute encoder	0 ... 2	0	RWE
26	velocity sensor selection	Feedback source for the velocity PI regulator. 0 - same as commutation 1 - ABN encoder 2 - absolute encoder	0 ... 2	0	RWE
27	velocity unit selection	Select mechanical or electrical velocity unit. 0 - mechanical rpm 1 - electrical rpm	0 ... 1	0	RWE

Number	Axis Parameter	Description	Range [Units]	Default	Access
30	target torque	Get desired target current or set target current to activate current regulation mode. (+= turn motor in right direction; -= turn motor in left direction)	–60000 ... 60000 [mA]	0	RW
31	actual torque	The actual motor current.	–2147483648 ... 2147483647 [mA]	0	R
32	target flux	Get desired target flux or set target flux to activate current regulation mode.	–60000 ... 60000 [mA]	0	RW
33	actual flux	The actual motor flux.	–2147483648 ... 2147483647 [mA]	0	R
40	target velocity	The desired target velocity.	–200000 ... 200000 [rpm]	0	RW
41	ramp velocity	The actual velocity of the velocity ramp used for positioning and velocity mode.	–2147483648 ... 2147483647 [rpm]	0	R
42	actual velocity	The actual velocity of the motor.	–2147483648 ... 2147483647 [rpm]	0	R
43	max velocity	Max. absolute velocity for velocity and positioning mode.	0 ... 200000 [rpm]	4000	RWE
44	acceleration	Acceleration parameter for ROL, ROR, and the velocity ramp of MVP.	0 ... 100000 [rpm/s]	2000	RWE
45	enable velocity ramp	An activated ramp allows a defined acceleration for velocity and position mode. 0 - Deactivate velocity ramp generator. 1 - Activate velocity ramp generator.	0 ... 1	1	RWE
47	motor halted velocity	If the actual velocity is below this value the motor halted flag will be set.	0 ... 200000 [rpm]	10	RWE
50	target position	The target position of a currently executed ramp.	–2147483648 ... 2147483647	0	RW
51	ramp position	The actual position of the position ramp used for positioning mode.	–2147483648 ... 2147483647	0	R
52	actual position	The actual position counter.	–2147483648 ... 2147483647	0	RW
53	position reached distance	Maximum distance at which the position end flag is set.	0 ... 100000	50	RWE

Number	Axis Parameter	Description	Range [Units]	Default	Access
54	position reached velocity	Max. velocity at which end position flag can be set. Prevents issuing of end position flag when the target is passed at high velocity.	0 ... 200000 [rpm]	500	RWE
55	position reached flag	This flag is set when actual position and velocity matches target position window. 0 - Position window not reached 1 - Position window reached	0 ... 1	0	R
56	position scaler	Scale the external position (external_position = (internal_position * scaler)/65536.	6 ... 2147483647	65536	RWE
70	torque P	P parameter for current PI regulator	0 ... 32767	500	RWE
71	torque I	I parameter for current PI regulator	0 ... 32767	500	RWE
72	velocity P	P parameter for velocity PI regulator	0 ... 32767	100	RWE
73	velocity I	I parameter for velocity PI regulator	0 ... 32767	100	RWE
74	position P	P parameter for position PI regulator	0 ... 32767	50	RWE
75	torque PI error sum	Sum of errors of current PI regulator.	-2147483648 ... 2147483647	0	R
76	flux PI error sum	Sum of errors of flux PI regulator.	-2147483648 ... 2147483647	0	R
77	velocity PI error sum	Sum of errors of velocity PI regulator.	-2147483648 ... 2147483647	0	R
78	torque PI error	Error of torque PI regulator.	-2147483648 ... 2147483647	0	R
79	flux PI error	Error of flux PI regulator.	-2147483648 ... 2147483647	0	R
80	velocity PI error	Error of velocity PI regulator.	-2147483648 ... 2147483647	0	R
81	position PI error	Error of position PI regulator.	-2147483648 ... 2147483647	0	R
90	hall polarity	Hall sensor polarity. 0 - standard 1 - inverted	0 ... 1	0	RWE
91	hall direction	Hall sensor direction. 0 - standard 1 - inverted	0 ... 1	0	RWE
92	hall interpolation	Hall sensor interpolation. 0 - off 1 - on	0 ... 1	0	RWE
93	hall phi_e offset	Offset for electrical angle hall_phi_e of hall sensor.	-32768 ... 32767	0	RWE

Number	Axis Parameter	Description	Range [Units]	Default	Access
94	hall inputs	Raw hall sensor inputs.	0 ... 7	0	R
100	encoder steps	Encoder steps per full motor rotation.	0 ... 16777215	4096	RWE
101	encoder direction	Set the encoder direction in a way, that ROR increases position counter. 0 - standard 1 - inverted	0 ... 1	0	RWE
102	encoder init mode	Select an encoder init mode that fits best to your motor's sensors. 0 - estimate offset 2 - use hall	0 ... 2	0	RWE
103	encoder init state	Actual state of encoder initialization. 0 - nothing to do 1 - start_init 2 - wait_init_time 3 - estimate_offset	0 ... 3	0	R
104	encoder init delay	Duration for encodersine initialization sequence. This parameter should be set in a way, that the motor has stopped mechanical oscillations after the specified time.	0 ... 10000 [ms]	1000	RWE
105	encoder init velocity	Init velocity for encoder initialization with encoder N-channel.	-200000 ... 200000 [rpm]	200	RWE
106	encoder offset	This value represents the internal commutation offset. (0...max. encoder steps per rotation).	0 ... 65535	0	RWE
107	clear on null	Clear the position counter on encoder N channel. 0 - do not clear position counter at next N channel event 1 - set position counter to zero at next N channel event	0 ... 1	0	RW
108	clear once	Clear the position counter on encoder N channel. 0 - clear position counter always at an N channel event 1 - set position counter to zero only once	0 ... 1	0	RW
109	encoder inputs	Raw ABN encoder inputs.	0 ... 7	0	R
110	Motor PWM frequency	Sets the frequency of the motor PWM.	25000 ... 100000 [Hz]	25000	RWE
111	encoder value	Raw ABN encoder value.	0 ... 16777215	0	R

Number	Axis Parameter	Description	Range [Units]	Default	Access
120	Release brake	Controls the external brake of the module. 0 - Brake PWM deactivated. 1 - Brake PWM activated.	0 ... 1	0	RW
121	Brake releasing duty cycle	Controls the duty cycle of the first PWM phase for releasing the brake.	0 ... 100 [%]	75	RWE
122	Brake holding duty cycle	Controls the duty cycle of the second PWM phase to hold the brake.	0 ... 100 [%]	20	RWE
123	Brake releasing duration	Controls the duration the brake PWM uses the first duty cycle.	0 ... 65535 [ms]	1000	RWE
124	Enable brake output	Enables the brake functionality 0 - Brake functionality enabled 1 - Brake functionality disabled	0 ... 1	0	RWE
125	Invert brake output	Inverts the brake output 0 - Brake output inverted 1 - Brake output normal	0 ... 1	0	RWE
140	enable brake chopper	Enable brake chopper functionality. 0 - Deactivate brake chopper. 1 - Activate brake chopper.	0 ... 1	0	RWE
141	brake chopper voltage limit	If the brake chopper is enabled and supply voltage exceeds this value, the brake chopper output will be activated.	50 ... 1000 [0.1V]	1000	RWE
142	brake chopper hysteresis	An activated brake chopper will be disabled if the actual supply voltage is lower than (limit voltage-hysteresis).	0 ... 50 [0.1V]	0	RWE
144	brake chopper active	A value unequal to zero indicates an active brake chopper.	0 ... 600	255	R
156	status flags	Actual status flags. 0x00000001 - OVERCURRENT 0x00000002 - UNDERVOLTAGE 0x00000004 - OVERVOLTAGE 0x00000008 - OVERTEMPERATURE 0x00000010 - MOTORHALTED 0x00000020 - HALLERROR 0x00000040 - DRIVER_ERROR 0x00000080 - INIT_ERROR 0x00000100 - STOP_MODE 0x00000200 - VELOCITY_MODE 0x00000400 - POSITION_MODE 0x00000800 - TORQUE_MODE 0x00004000 - POSITION_END 0x00008000 - MODULE_INITIALIZED	0 ... 4294967295	0	R

Number	Axis Parameter	Description	Range [Units]	Default	Access
160	absolute encoder type	Select the used absolute encoder 0 - disabled 1 - AMT20 2 - AMT23 3 - MBD01_18B 4 - MBD01_19B 200 - GENERIC_SSI	0 ... 200	0	RWE
161	absolute encoder init	Select the used absolute encoder init mode 0 - estimate offset 1 - use offset	0 ... 1	0	RWE
162	absolute encoder direction	Set the absolute encoder direction in a way, that ROR increases position counter. 0 - standard 1 - inverted	0 ... 1	0	RWE
163	absolute encoder offset	This value represents the internal commutation offset. (0...max. encoder steps per rotation).	0 ... 65535	0	RWE
165	absolute encoder data length	Number of bits per SSI datagram	0 ... 255	0	RWE
166	absolute encoder position start	Position of the Least significant singleturn bit in SSI datagram	0 ... 255	0	RWE
167	absolute encoder position length	Number of singleturn bits	0 ... 255	0	RWE
209	reference switch enable	REF_H = Bit_2, REF_L = Bit_1, REF_R = Bit_0 Bit_x = 1 - Reference switch functionality is enabled. Bit_x = 0 - Reference switch functionality is disabled.	0 ... 7	0	RWE
210	reference switch polarity	REF_H = Bit_2, REF_L = Bit_1, REF_R = Bit_0 Bit_x = 1 - Reference switch is high active. Bit_x = 0 - Reference switch is low active.	0 ... 7	0	RWE
211	right reference switch active	0 - Right reference switch deactivated. 1 - Right reference switch activated.	0 ... 1	0	R
212	left reference switch active	0 - Left reference switch deactivated. 1 - Left reference switch activated.	0 ... 1	0	R

Number	Axis Parameter	Description	Range [Units]	Default	Access
213	home reference switch active	0 - Home reference switch deactivated. 1 - Home reference switch activated.	0 ... 1	0	R
220	supply voltage	The actual supply voltage.	0 ... 1000 [100mV]	480	R
221	driver temperature	The actual temperature of the motor driver.	-20 ... 150 [°C]	0	R
230	Main loops	Main loops per second.	0 ... 4294967295 [1/s]	0	R
231	Torque loops	Torque loops per second.	0 ... 4294967295 [1/s]	0	R
232	Velocity loops	Velocity loops per second.	0 ... 4294967295 [1/s]	0	R
240	debug value 0	Free used debugging value.	-2147483648 ... 2147483647	0	RW
241	debug value 1	Free used debugging value.	-2147483648 ... 2147483647	0	RW
242	debug value 2	Free used debugging value.	-2147483648 ... 2147483647	0	RW
243	debug value 3	Free used debugging value.	-2147483648 ... 2147483647	0	RW
244	debug value 4	Free used debugging value.	-2147483648 ... 2147483647	0	RW
245	debug value 5	Free used debugging value.	-2147483648 ... 2147483647	0	RW
246	debug value 6	Free used debugging value.	-2147483648 ... 2147483647	0	RW
247	debug value 7	Free used debugging value.	-2147483648 ... 2147483647	0	RW
248	debug value 8	Free used debugging value.	-2147483648 ... 2147483647	0	RW
249	debug value 9	Free used debugging value.	-2147483648 ... 2147483647	0	RW
255	enable driver	Enables the motor driver (enabled by default) 0 - driver disabled 1 - driver enabled	0 ... 1	1	RW

Table 12: All TMCM-1636 Axis 0 Parameters

4 Global Parameters

The following sections describe all global parameters that can be used with the SGP, GGP, AGP, STGP and RSGP commands. Global parameters are grouped into banks:

- Bank 0: Global configuration of the module.
- Bank 2: TMCL user variables.

4.1 Bank 0

Parameters with numbers from 64 on configure all settings that affect the overall behaviour of a module. These are things like the serial address, the RS485 baud rate or the CAN bit rate (where appropriate). Change these parameters to meet your needs. The best and easiest way to do this is to use the appropriate functions of the TMCL-IDE. The parameters with numbers between 64 and 128 are automatically stored in the EEPROM.

Note

- An SGP command on such a parameter will always store it permanently and no extra STGP command is needed.
- Take care when changing these parameters, and use the appropriate functions of the TMCL-IDE to do it in an interactive way.
- Some configurations of the interface (for example baud rates that are not supported by the PC) may lead to the fact that the module cannot be reached any more. In such a case please see the TMC1636 Hardware Manual on how to reset all parameters to factory default settings.
- Some settings (especially interface bit rate settings) do not take effect immediately. For those settings, power cycle the module after changing them to make the changes take effect.

There are different parameter access types, like read only or read/write. Table 13 shows the different parameter access types used in the global parameter tables.

Meaning of the Letters in the Access Column		
Access type	Command	Description
R	GGP	Parameter readable
W	SGP, AGP	Parameter writable
E	STGP, RSGP	Parameter can be stored in the EEPROM
A	SGP	Automatically stored in the EEPROM

Table 13: Meaning of the Letters in the Access Column

All Global Parameters of the TMCM-1636 Module in Bank 0					
Number	Global Parameter	Description	Range [Units]	Default	Access
65	serial baud rate	RS485/RS232 baud rate 0 - 9600 [kBit/s] 1 - 14400 [kBit/s] 2 - 19200 [kBit/s] 3 - 28800 [kBit/s] 4 - 38400 [kBit/s] 5 - 57600 [kBit/s] 6 - 76800 [kBit/s] 7 - 115200 [kBit/s]	0 ... 7	7	RW
66	serial address	The module (target) address for RS485, RS232, and virtual COM port.	1 ... 255	2	RWX
69	CAN bit rate	CAN bit rate 2 - 20 [kBit/s] 3 - 50 [kBit/s] 4 - 100 [kBit/s] 5 - 125 [kBit/s] 6 - 250 [kBit/s] 7 - 500 [kBit/s] 8 - 1000 [kBit/s]	2 ... 8	8	RW
70	CAN send ID	The CAN send ID of the module.	0 ... 255	2	RWX
71	CAN receive ID	The CAN receive ID of the module.	0 ... 255	1	RWX
75	telegram pause time	Pause time before the reply via RS485/RS232 is sent.	0 ... 255 [ms]	0	RWX
76	serial host address	Host address used in the reply telegrams sent back via RS485/RS232.	1 ... 255	1	RWX
77	auto start mode	Use automatic TMCL application start after power up. 0 - do not start TMCL application after power up 1 - start TMCL application automatically after power up	0 ... 1	1	RWX
128	application status	Actual TMCL application status. 0 - stop 1 - run 2 - step 3 - reset	0 ... 3	0	R
130	program counter	TMCL program counter.	0 ... 4294967295	0	R
132	tick timer	TMCL tick timer.	0 ... 4294967295	0	RW

Table 14: All Global Parameters of the TMCM-1636 Module in Bank 0

4.2 Bank 2

Bank 2 contains general purpose 32 bit variables for use in TMCL applications. They are located in RAM and the first 56 variables can also be stored permanently in the EEPROM. After booting, their values are automatically restored to the RAM. Up to 256 user variables are available. Please see table 13 for an explanation of the different parameter access types.

User Variables in Bank 2				
Number	Global Parameter	Description	Range [Units]	Access
0...55	user variables #0...#55	TMCL user variables	-2147483648 ... 2147483647	RWE
56...255	user variables #56...#255	TMCL user variables	-2147483648 ... 2147483647	RWE

Table 15: User Variables in Bank 2

5 Getting Started

5.1 Absolute Encoders

For directly supported absolute encoders the setup procedure using the TMCL-IDE is straight forward.

- Select the encoder type in the axis 0 settings dialogue.

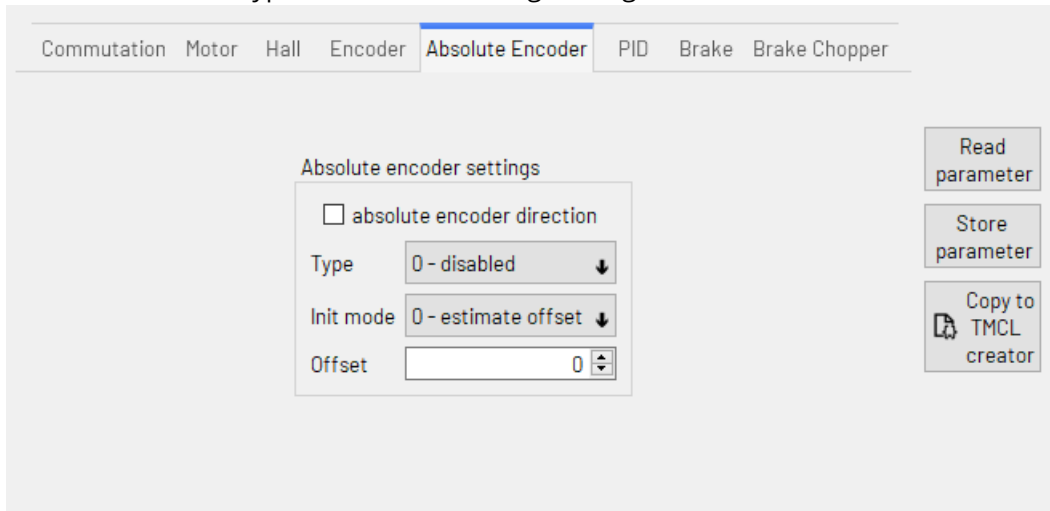

- Start the TMCM-1636's wizard (Servo quick start wizard).

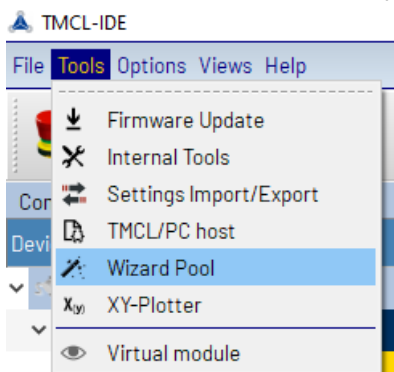

Optionally you can skip the Hall and ABN encoder configuration inside the wizard. Whereas the absolute encoder configuration is important, in which you determine if the encoder positive counting direction is aligned with the motor positive direction, and in case the encoder counts up in the opposite direction, you need to invert the direction.

- Now you are ready to e.g. change the commutation mode to mode 3 (absolute encoder commutation) and/or use the absolute encoder for velocity and position feedback.

When using the "Generic SSI" encoder type, you also need to configure axis parameter 165, 167 and 168, before going through the wizard.

5.1.1 ATM20

Encoders from the ATM20 family are SPI based encoders. Wiring is done like in the figure below.

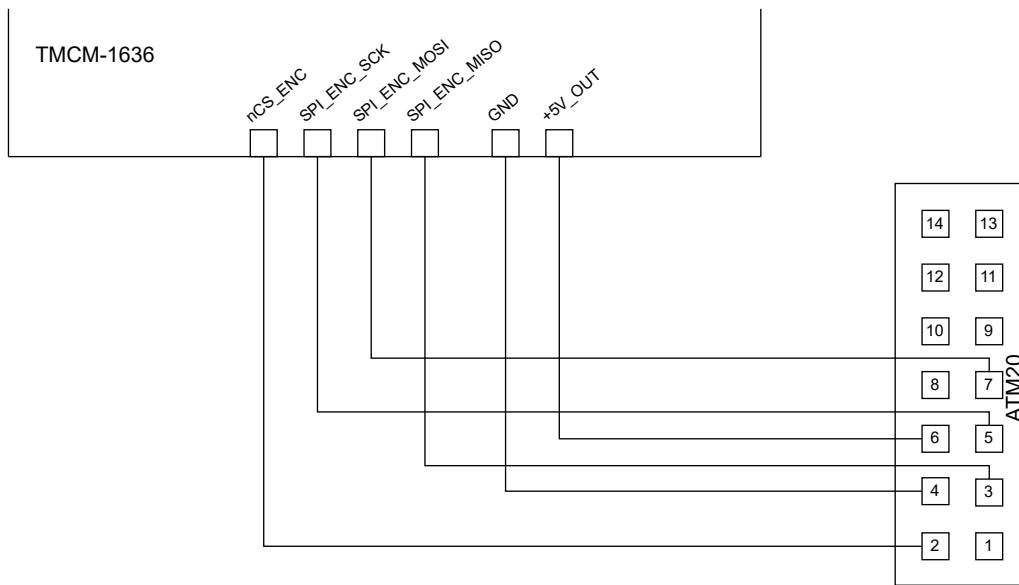

Figure 1: Connecting an ATM20 absolute encoder.

Keep cable lengths short, and provide adequate shielding!

5.1.2 ATM23

Special wiring and a RS422 converter circuit is needed for encoders from the ATM23 family, as they use the SSI protocol but on TTL level.

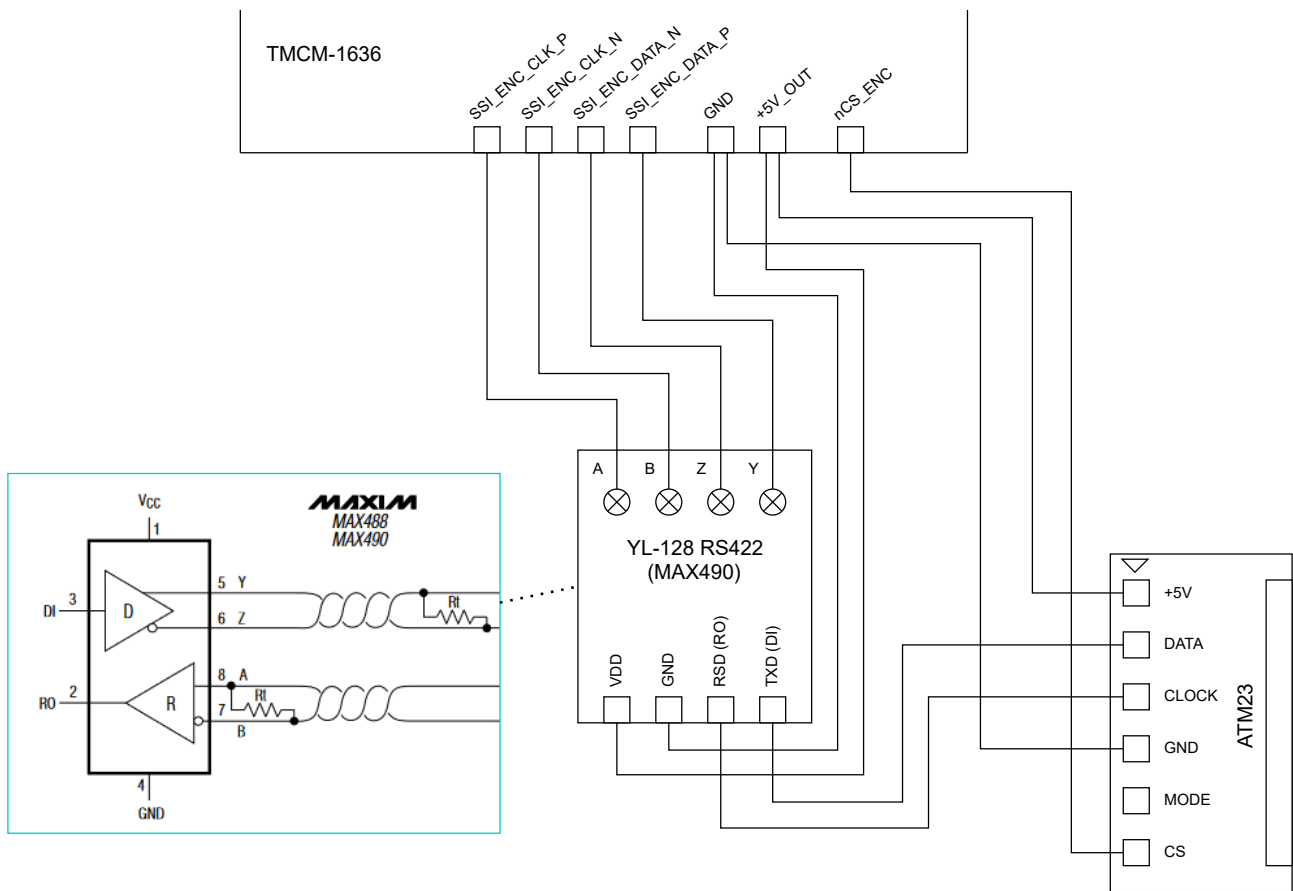

Figure 2: Connecting an ATM23 absolute encoder.

5.2 External Brake Control

The TMCM-1636 features a break output that can be controlled by axis parameter 120. Axis parameter 121 to 125 are used to configure the break signal.

Figure 3 shows the break output signal in both inverted and non-inverted mode. Once the brake is released by setting axis parameter 120 to 1, the brake releasing phase is started where the “Brake releasing duty cycle” (axis parameter 121) is applied. After the “Break releasing duration” (axis parameter 123) the holding phase starts where the “Brake holding duty cycle” (axis parameter 123) is applied. The holding phase lasts till the brake releasing is stopped by setting axis parameter 120 back to 0.

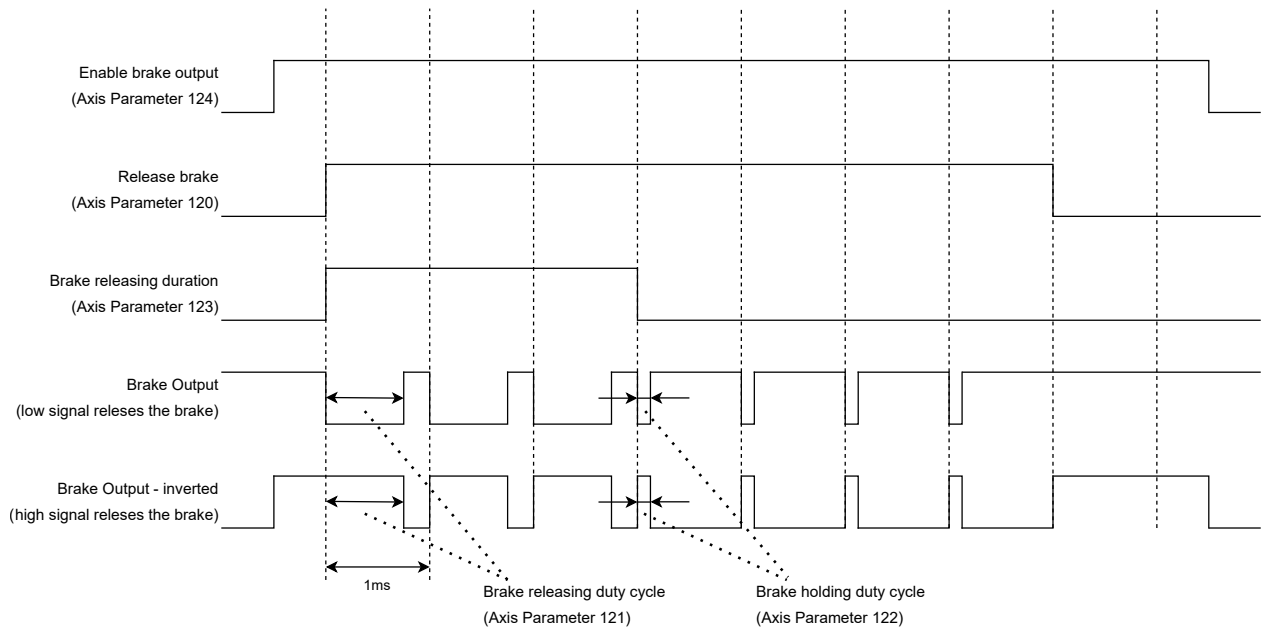

Figure 3: Example timing diagram for the brake control.

6 TMCL Programming Techniques and Structure

6.1 Initialization

The first task in a TMCL program (like in other programs also) is to initialize all parameters where different values than the default values are necessary. For this purpose, SAP and SGP commands are used.

6.2 Main Loop

Embedded systems normally use a main loop that runs infinitely. This is also the case in a TMCL application that is running stand alone. Normally the auto start mode of the module should be turned on. After power up, the module then starts the TMCL program, which first does all necessary initializations and then enters the main loop, which does all necessary tasks end never ends (only when the module is powered off or reset).

There are exceptions to this, e.g. when TMCL routines are called from a host in direct mode.

So most (but not all) stand alone TMCL programs look like this:

```

1 //Initialization
  SAP 43, 0, 5000 //define maximum positioning speed
3  SAP 44, 0, 1000 //define maximum acceleration

5 MainLoop:
  //do something, in this example just running between two positions
7  MVP ABS, 0, 5000
  WAIT POS, 0, 0
9  MVP ABS, 0, 0
  WAIT POS, 0, 0
11 JA MainLoop //end of the main loop => run infinitely

```

6.3 Using Symbolic Constants

To make your program better readable and understandable, symbolic constants should be taken for all important numerical values that are used in the program. The TMCL-IDE provides an include file with symbolic names for all important axis parameters and global parameters. Please consider the following example:

```

1 //Define some constants
  #include TMCLParam.tmc
3  MaxSpeed = 50000
  MaxAcc = 10000
5  Position0 = 0
  Position1 = 500000
7
9  //Initialization
  SAP APMaxPositioningSpeed, Motor0, MaxSpeed
  SAP APMaxAcceleration, Motor0, MaxAcc
11
13 MainLoop:
  MVP ABS, Motor0, Position1
  WAIT POS, Motor0, 0
15  MVP ABS, Motor0, Position0

```

```

17  WAIT POS, Motor0, 0
    JA MainLoop

```

Have a look at the file `TMCLParam.tmc` provided with the TMCL-IDE. It contains symbolic constants that define all important parameter numbers.

Using constants for other values makes it easier to change them when they are used more than once in a program. You can change the definition of the constant and do not have to change all occurrences of it in your program.

6.4 Using Variables

The user variables can be used if variables are needed in your program. They can store temporary values. The commands SGP, GGP and AGP as well as STGP and RSGP are used to work with user variables:

- SGP is used to set a variable to a constant value (e.g. during initialization phase).
- GGP is used to read the contents of a user variable and to copy it to the accumulator register for further usage.
- AGP can be used to copy the contents of the accumulator register to a user variable, e.g. to store the result of a calculation.
- The STGP command stores the contents of a user variable in the EEPROM.
- The RSGP command copies the value stored in the EEPROM back to the user variable.
- Global parameter 85 controls if user variables will be restored from the EEPROM automatically on startup (default setting) or not (user variables will then be initialized with 0 instead).

Please see the following example:

```

1  MyVariable = 42
   //Use a symbolic name for the user variable
3  //(This makes the program better readable and understandable.)

5  SGP MyVariable, 2, 1234 //Initialize the variable with the value 1234
   ...
7  ...
   GGP MyVariable, 2 //Copy contents of variable to accumulator register
9  CALC MUL, 2 //Multiply accumulator register with two
   AGP MyVariable, 2 //Store contents of accumulator register to variable
11 ...
   ...

```

Furthermore, these variables can provide a powerful way of communication between a TMCL program running on a module and a host. The host can change a variable by issuing a direct mode SGP command (remember that while a TMCL program is running direct mode commands can still be executed, without interfering with the running program). If the TMCL program polls this variable regularly it can react on such changes of its contents.

The host can also poll a variable using GGP in direct mode and see if it has been changed by the TMCL program.

6.5 Using Subroutines

The CSUB and RSUB commands provide a mechanism for using subroutines. The CSUB command branches to the given label. When an RSUB command is executed the control goes back to the command that follows the CSUB command that called the subroutine.

This mechanism can also be nested. From a subroutine called by a CSUB command other subroutines can be called. In the current version of TMCL eight levels of nested subroutine calls are allowed.

6.6 Combining Direct Mode and Standalone Mode

Direct mode and standalone mode can also be combined. When a TMCL program is being executed in standalone mode, direct mode commands are also processed (and they do not disturb the flow of the program running in standalone mode). So, it is also possible to query e.g. the actual position of the motor in direct mode while a TMCL program is running.

Communication between a program running in standalone mode and a host can be done using the TMCL user variables. The host can then change the value of a user variable (using a direct mode SGP command) which is regularly polled by the TMCL program (e.g. in its main loop) and so the TMCL program can react on such changes. Vice versa, a TMCL program can change a user variable that is polled by the host (using a direct mode GGP command).

A TMCL program can be started by the host using the run command in direct mode. This way, also a set of TMCL routines can be defined that are called by a host. In this case it is recommended to place JA commands at the beginning of the TMCL program that jump to the specific routines. This assures that the entry addresses of the routines will not change even when the TMCL routines are changed (so when changing the TMCL routines the host program does not have to be changed).

Example:

```
//Jump commands to the TMCL routines
2 Func1:  JA Func1Start
  Func2:  JA Func2Start
4 Func3:  JA Func3Start

6 Func1Start:
  MVP ABS, 0, 1000
8  WAIT POS, 0, 0
  MVP ABS, 0, 0
10 WAIT POS, 0, 0
  STOP

12 Func2Start:
14  ROL 0, 500
  WAIT TICKS, 0, 100
16  MST 0
  STOP

18 Func3Start:
20  ROR 0, 1000
  WAIT TICKS, 0, 700
22  MST 0
  STOP
```

This example provides three very simple TMCL routines. They can be called from a host by issuing a run command with address 0 to call the first function, or a run command with address 1 to call the second function, or a run command with address 2 to call the third function. You can see the addresses of the TMCL labels (that are needed for the run commands) by using the "Generate symbol file function" of the TMCL-IDE.

6.7 Make the TMCL Program start automatically

For stand-alone operation the module has to start the TMCL program in its memory automatically after power-on. In order to achieve this, switch on the Autostart option of the module. This is controlled by global parameter #77. There are different ways to switch on the Autostart option:

- Execute the command SGP 77, 0, 1 in direct mode (using the Direct Mode tool in the TMCL-IDE).
- Use the Global Parameters tool in the TMCL-IDE to set global parameter #77 to 1.
- Use the Autostart entry in the TMCL menu of the TMCL Creator in the TMCL-IDE. Go to the Autostart entry in the TMCL menu and select "On".

7 Figures Index

1	Connecting an ATM20 absolute encoder.	64	3	Example timing diagram for the brake control.	66
2	Connecting an ATM23 absolute encoder.	65			

8 Tables Index

1	TMCL Command Format	6	11	Meaning of the Letters in the Access Column	52
2	TMCL Reply Format	7	12	All TMCM-1636 Axis 0 Parameters	59
3	TMCL Status Codes	7	13	Meaning of the Letters in the Access Column	60
4	Overview of all TMCL Commands	10	14	All Global Parameters of the TMCM-1636 Module in Bank 0	61
5	Motion Commands	10	15	User Variables in Bank 2	62
6	Parameter Commands	11	16	Firmware Revision	75
7	Branch Commands	11	17	Document Revision	76
8	I/O Port Commands	12			
9	Calculation Commands	12			
10	TMCL Control Commands	51			

9 Supplemental Directives

9.1 Producer Information

9.2 Copyright

TRINAMIC owns the content of this user manual in its entirety, including but not limited to pictures, logos, trademarks, and resources. © Copyright 2022 TRINAMIC. All rights reserved. Electronically published by TRINAMIC, Germany.

Redistribution of sources or derived formats (for example, Portable Document Format or Hypertext Markup Language) must retain the above copyright notice, and the complete data sheet, user manual, and documentation of this product including associated application notes; and a reference to other available product-related documentation.

9.3 Trademark Designations and Symbols

Trademark designations and symbols used in this documentation indicate that a product or feature is owned and registered as trademark and/or patent either by TRINAMIC or by other manufacturers, whose products are used or referred to in combination with TRINAMIC's products and TRINAMIC's product documentation.

This TMCL™ Firmware Manual is a non-commercial publication that seeks to provide concise scientific and technical user information to the target user. Thus, trademark designations and symbols are only entered in the Short Spec of this document that introduces the product at a quick glance. The trademark designation /symbol is also entered when the product or feature name occurs for the first time in the document. All trademarks and brand names used are property of their respective owners.

9.4 Target User

The documentation provided here, is for programmers and engineers only, who are equipped with the necessary skills and have been trained to work with this type of product.

The Target User knows how to responsibly make use of this product without causing harm to himself or others, and without causing damage to systems or devices, in which the user incorporates the product.

9.5 Disclaimer: Life Support Systems

TRINAMIC Motion Control GmbH & Co. KG does not authorize or warrant any of its products for use in life support systems, without the specific written consent of TRINAMIC Motion Control GmbH & Co. KG.

Life support systems are equipment intended to support or sustain life, and whose failure to perform, when properly used in accordance with instructions provided, can be reasonably expected to result in personal injury or death.

Information given in this document is believed to be accurate and reliable. However, no responsibility is assumed for the consequences of its use nor for any infringement of patents or other rights of third parties which may result from its use. Specifications are subject to change without notice.

9.6 Disclaimer: Intended Use

The data specified in this user manual is intended solely for the purpose of product description. No representations or warranties, either express or implied, of merchantability, fitness for a particular purpose

or of any other nature are made hereunder with respect to information/specification or the products to which information refers and no guarantee with respect to compliance to the intended use is given.

In particular, this also applies to the stated possible applications or areas of applications of the product. TRINAMIC products are not designed for and must not be used in connection with any applications where the failure of such products would reasonably be expected to result in significant personal injury or death (safety-Critical Applications) without TRINAMIC's specific written consent.

TRINAMIC products are not designed nor intended for use in military or aerospace applications or environments or in automotive applications unless specifically designated for such use by TRINAMIC. TRINAMIC conveys no patent, copyright, mask work right or other trade mark right to this product. TRINAMIC assumes no liability for any patent and/or other trade mark rights of a third party resulting from processing or handling of the product and/or any other use of the product.

9.7 Collateral Documents & Tools

This product documentation is related and/or associated with additional tool kits, firmware and other items, as provided on the product page at: www.trinamic.com.

10 Revision History

10.1 Firmware Revision

Version	Date	Author	Description
1.02	27-NOV-2019	ED, SW	First release.
1.09	18-MAY-2020	ED, SW	Launch release.
1.12	24-SEP-2020	ED	Bugfix for UART input. Added axis parameter 13, 26, 56, 94, 109, 165, 166 and 167.
1.13	30-MAY-2022	BP	Bugfix and update release. <ul style="list-style-type: none"> • Add missing limit checks for some axis parameters. • Add missing implementation for axis parameter 107 and 108. • Fix wrong behavior of RSAP command for some axis parameter. • Fix the “Motor Rotates” status flag not going active when the motor turns. • Add indication of over-current events on the error LED. • Activate space vector PWM.

Table 16: Firmware Revision

10.2 Document Revision

Version	Date	Author	Description
1.00	27-NOV-2019	TMC	First release.
1.01	09-JUN-2020	TMC	Launch release.
1.02	28-SEP-2020	TMC	Added axis parameter 13 (motor direction), 26 (velocity selection), 56 (position scaler), 165-167 (generic SSI encoder), 94 and 109. Removed wrong motor regulation chapter.
1.03	05-FEB-2021	TMC	Removed superfluous RFS option in WAIT command description.
1.04	08-MAR-2021	TMC	Removed analog encoder option.

Version	Date	Author	Description
1.05	30-MAY-2022	BP	<p>New firmware release (1.13). Corrected the axis parameter section:</p> <ul style="list-style-type: none"> • Fixed the default values for axis parameter 5 and 6 (adc offsets), 11 (max current), 53 (position reached distance), 70 (torque P), 71 (torque I), 72 (velocity P), 73 (velocity I), 74 (position P), 100 (encoder steps), 105 (encoder init velocity), 122 (Brake holding duty cycle), 123 (Brake releasing duration), 141 (brake chopper voltage limit) and 142 (brake chopper hysteresis) • Fixed non-volatile storage for axis parameter 107 (clear on null) and 108 (clear once) • Removed the Xs in the access column. • Fix the description for axis parameter 14 (motor type), 25 (position sensor selection) and 26 (velocity sensor selection). • Remove the D from "PID regulators". • Add axis parameter 27 (velocity unit selection), 47 (motor halted velocity) and 111 (encoder value). • Add definition of the motor status flags (axis parameter 156). <p>Removed 2x incremental encoder support - only one is supported. Changed the front page product text - the UART interface should only be used as secondary configuration interface. Added section 5 (Getting Started).</p>

Table 17: Document Revision