

LT1990, LT1991, and LT1995
 Configurable-Gain Amplifiers

DESCRIPTION

Demonstration circuit 819 is a jumper definable evaluation platform featuring the LT1990, LT1991, and LT1995 Configurable-Gain Amplifiers.

The micropower LT1990 offers high-voltage inputs and selectable difference gains of 1 or 10. The LT1991 is highly flexible micropower general-purpose precision amplifier for gains up to 14. The LT1995 is a high-speed configurable amplifier for gains up to 8. DC819 provides all three of these parts along with signal connectors and jumper fields that allow rapid prototyping and evaluation

in various configurations. The DC819 layout includes footprints for TSOT-23-6 and other generic components that may be associated with a more complex evaluation. The Performance Summary below highlights some of the key differences in the parts on this evaluation platform.

Design files for this circuit board are available. Call the LTC factory.

 , LTC and LT are registered trademarks of Linear Technology Corporation.

PERFORMANCE SUMMARY

Specifications are at $T_A = 25^\circ\text{C}$

SYMBOL	PARAMETER	CONDITIONS	MIN	TYP	MAX	UNITS
V_S	Supply Range	All parts able to operate	± 2.5		± 15	V
I/O	Input & Output Signals	BNC connectors		VREF VIN- VIN+ VOUT		
Gain	Gain-Configurability Range: LT1990 LT1991 LT1995	Difference-Amplifier Configuration	± 1 ± 1 ± 1	Or to to	± 10 ± 13 ± 7	
BW	Bandwidth: LT1990 LT1991 LT1995	G=10 G=9 G=7		6.5 40 10000		kHz
V_{OS}	Input Offset Voltage: LT1990 LT1991 LT1995	G=1,10 G=1 G=1		0.8 0.025 1	3 0.1 5	mV
SR	Slew Rate: LT1990 LT1991 LT1995	G=1 G=-2		0.5 0.12 450		V/ μ s

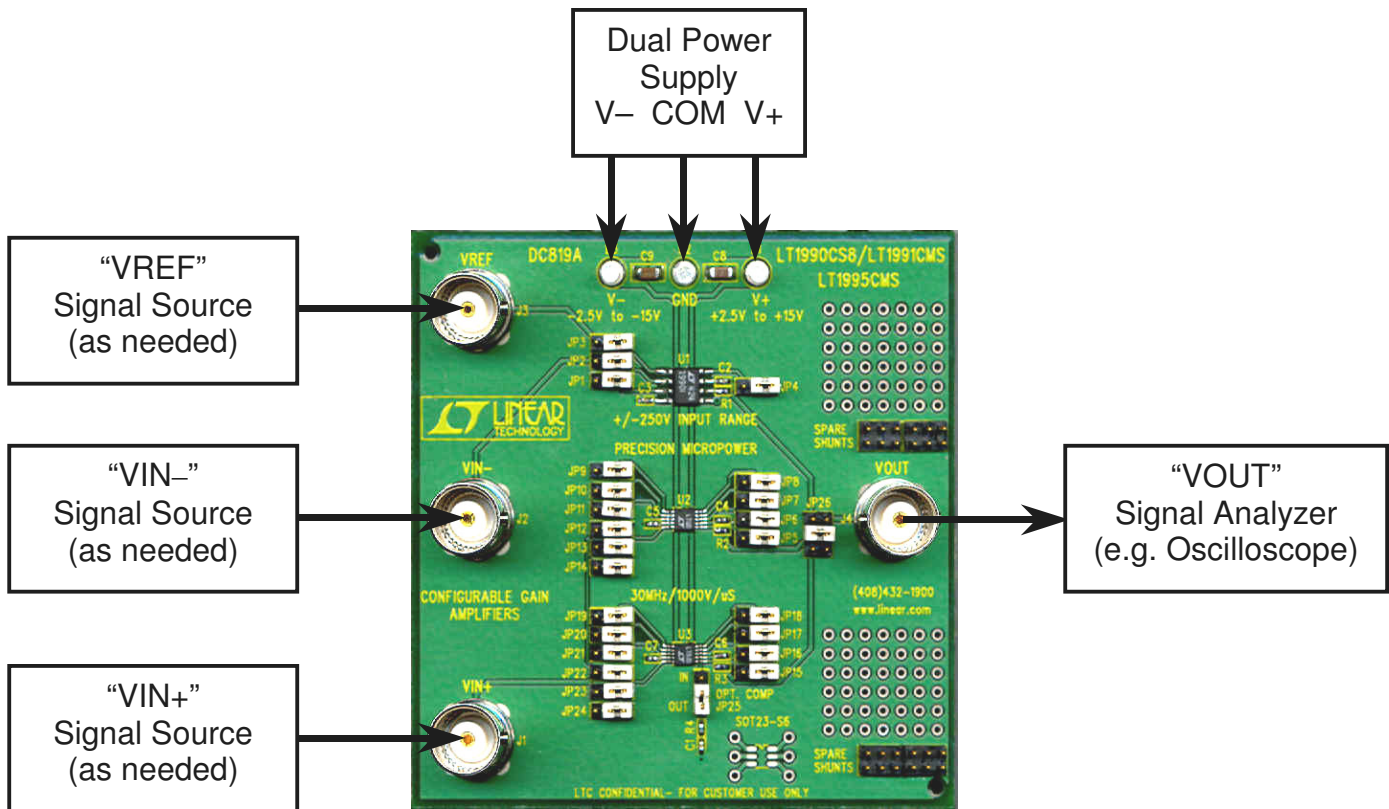

Figure 2. Proper Measurement Equipment Setup

Item	Qty	Ref-Des	Desc	Manufacturer's Part Number
1	3	C1,C2,C3	CAP, X7R 10nF 25V 10% 0402	AVX 04023C103KAT
2	4	C4,C5,C6,C7	CAP, X5R 100nF 16V 10% 0402	AVX 0402YD104K
3	2	C9,C8	CAP, X5R 4.7uF 16V 20% 1206	TAIYO YUDEN EMK316BJ475ML-T
4	3	E1,E2,E3	TURRETS	MILLMAX 2501-2
5	25	JP1-JP25	HEADER,3PIN, 2mm	COMM CON 2802S-03G2
6	5	JP26,SPARE SHUNTS	HEADER, 3X2 2mm	COMM CON 2202S-06G1
7	4	J1,J2,J3,J4	CONN,BNC,5 PINS	CONNEX 112404
8	3	R1,R2,R3	RES, 49.9 OHMS 1% 1/16W 0402	ACC CR05-49R9FM
9	1	R4	RES, 47 OHMS 1% 1/16W 0402	ACC CR05-470FM
10	1	U1	IC, LT1990CS8	LINEAR TECH LT1990CS8
11	1	U2	IC, LT1991CMS	LINEAR TECH LT1991CMS
12	1	U3	IC, LT1995CMS	LINEAR TECH LT1995CMS
13	26	JP1-JP26	SHUNTS	COMM CON CCIJ2MM-138G

Figure 3. DC819 Bill-of-Material

OPERATING PRINCIPLES

This demo circuit can actually be considered as three circuits in one. As can be seen from the electrical schematic in Figure 1, jumpers define which devices are coupled to the I/O connections and what specific configuration the amplifiers take on. All three parts are powered from a common split-supply bus, so the unused devices are usually strapped so their inputs are grounded to avoid unpredictable behavior. Each amplifier output includes a 50Ω series resistor to decouple instrument cable capacitance from the part, assuring stable behavior during evaluation. The single BNC output connector (VOUT, J4) is tied to the desired evaluation part by configuration of JP26. BNC input connectors are provided for a non-inverting input (VIN+, J1), an inverting input (VIN-, J2), and a reference voltage input (VREF, J3).

The LT1990 section includes input configuration jumpers JP1, JP2, and JP3 that establish which signals get applied to the device. JP4 configures the gain for 1 or 10. With a JP26 jumper connecting the upper pin-pair, the LT1990 output is passed to the VOUT connector. When the LT1990 is not in use, it is recommended that JP1-JP4 be strapped toward the right (with silkscreen right-reading; i.e. connecting the middle and right pins together with the jumper; contacts 2 & 3 on the schematic).

The LT1991 is more complicated, with the inverting input jumpers JP5-JP8 allowing either VIN-, ground, or feedback connections to the “M” pins of the device. Its non-

inverting input jumpers JP9-JP14 allow the “P” inputs to be tied to VIN+, ground, or VREF. The LT1991 output is available on VOUT (J4) when jumper JP26 is in the middle position. Accomplishing cross-coupled input topologies requires some soldered wiring to be added as appropriate. When the LT1991 is not in use, it is recommended that jumpers JP5-JP14 be placed to the right (contacts 2 & 3 tied).

The LT1995 configuration is nearly identical to the LT1991, though gains are different for similar connections. The inverting input jumpers JP15-JP18 allow either VIN-, ground, or feedback connections to the “M” pins of the device. Its non-inverting input jumpers JP19-JP24 allow the “P” inputs to be tied to VIN+, ground, or VREF. The LT1991 output is available on VOUT (J4) when jumper JP26 is in the lower position. The LT1995 also has an optional compensation network (C1 & R4) that can be invoked with jumper JP25 in the upper position. The compensation may be desirable when gains less than 2 are used. When the LT1995 is not in use, it is recommended that jumpers JP15-JP24 be placed to the right (contacts 2 & 3 tied).

In some configurations, jumpers must be removed completely, so storage posts are made available at the right side of the layout to provide “parking” space for the spares.

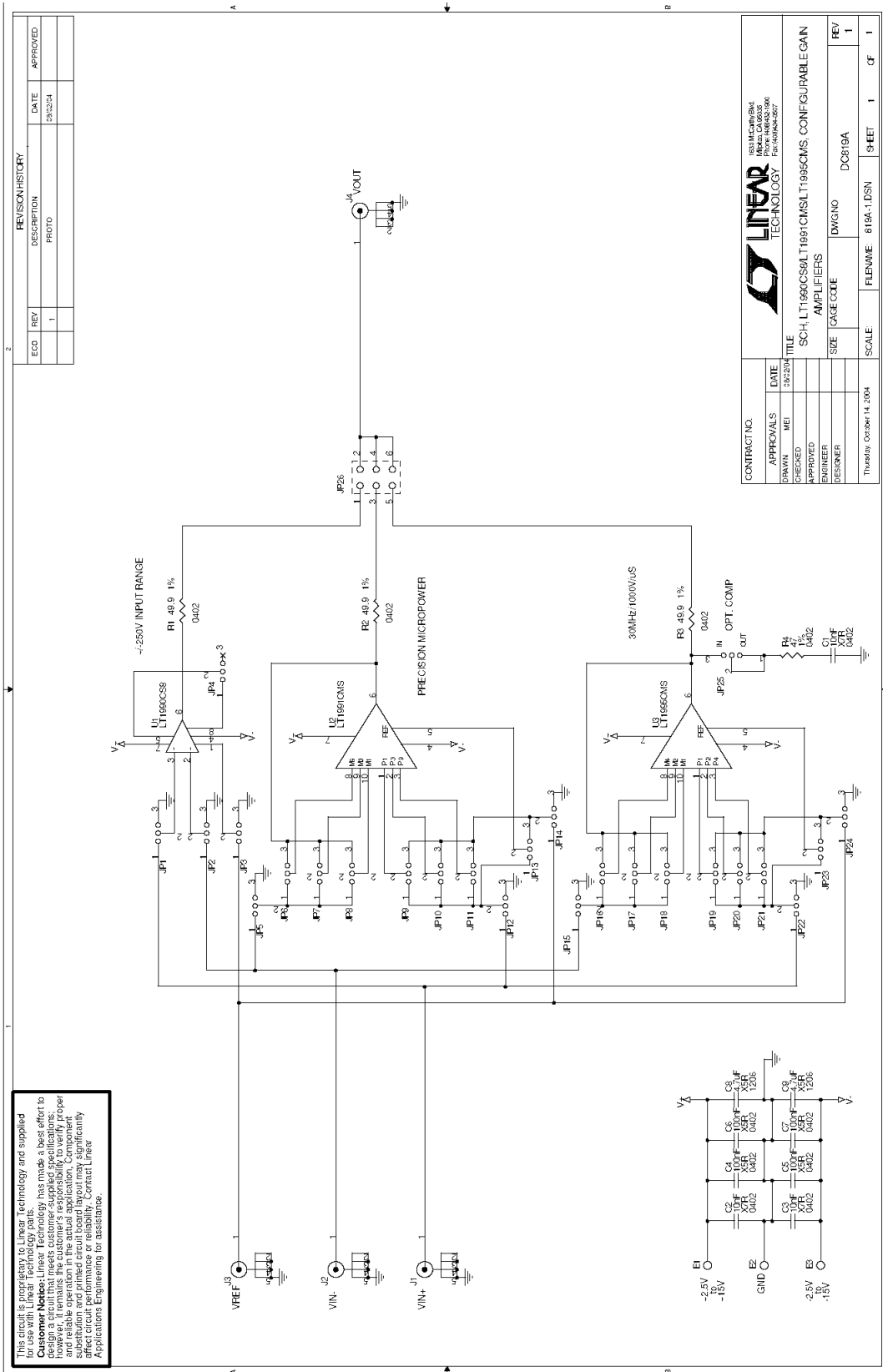

Figure 1. DC819 Electrical Schematic Diagram

QUICK START PROCEDURE

Demonstration circuit 819 is easy to set up to evaluate the performance of the LT1990, LT1991, and LT1995. Refer to Figure 2 for proper measurement equipment setup and follow the procedure below (the bullets indicate the specifics of a particular example scenario):

1. Configure the jumper field of one evaluation device to create a desired test circuit. Refer to Figure 1 and the device datasheet to determine the appropriate topology to employ.
 - As an example, configure the LT1995 as a “Gain of 2.66 Non-inverting Buffer”:
 - **JP15, JP17, JP24** to the right (connecting posts 2 & 3);
 - **JP16, JP18–JP23** to the left (connecting posts 1 & 2);
 - **JP25** to the lower position (OPT. COMP “OUT”).

Note. In some situations, additional hardwiring may be required. This will be the case when implementing LT1991 “cross-coupled” topologies, or if populating the SOT23-6 pads (with an LT6650 adjustable voltage reference, for example). Some topologies will require removal of jumpers, in which case they may be stored in the SPARE SHUNTS areas provided.

2. Place jumpers of the unused devices in the following positions:

JP1–JP4 To the right if LT1990 not used (connecting posts 2 & 3);

JP5–JP14 To the right if LT1991 not used (connecting posts 2 & 3);

JP15–JP24 To the right if LT1995 not used (connecting posts 2 & 3).

- In the LT1995 example, verify that JP1–JP14 are each in the right-hand position.
3. With power off, connect the input power supply to V–, GND, and V+.
 4. Connect signal source(s) as required (and activate).
 - In the LT1995 example, connect a signal generator to VIN+ (**J1**). Set the generator to produce a 1MHz square-wave of 1V_{P-P}.
 5. Configure **JP26** to direct the active device output to VOUT (**J4**):
 - The upper position connects the LT1990;
 - The mid position connects the LT1991;
 - The lower position connects the LT1995.
 - In the LT1995 example, configure **JP26** to the lower position.
 6. Turn on the power supply.
 - Note.** Make sure that the input voltage does not exceed ±18V.
 7. Check for the proper output waveform at VOUT (**J4**). Generally this will be done by monitoring the **J4** center contact with an oscilloscope probe (connect the probe ground to the GND turret or a BNC connector body).
 - Note.** A 50Ω cable may be used to connect J4 with an oscilloscope hi-Z input; an on-board source resistor will prevent C-loading or reflections on the line.
 - In the LT1995 example, the output waveform should be a 2.66V_{P-P} square-wave. Any dc-offset at the signal source will also appear amplified at the output by 2.66 in this configuration.