

## General Description

The MAX96792A converts dual GMSL3/2 serial inputs to MIPI CSI-2. It receives forward-channel video data, and simultaneously receives and transmits bidirectional control channel data over Coaxial or Shielded-Twisted Pair (STP) cables. The PAM-4 based GMSL3 serial link operates at 12Gbps in the forward direction and 187.5Mbps in reverse direction. The MAX96792A is backward compatible with GMSL2 and can be paired with 6Gbps or 3Gbps GMSL2 serializers. The GMSL inputs operate independently, allowing video with different timing and resolution to be received on each input. The two GMSL links can also have different data rates. Video data from both inputs can be aggregated for output on a single CSI-2 port and can be replicated on a second output port for redundant processing. The device is configured using an I<sup>2</sup>C or UART interface. GPIO, I<sup>2</sup>C, UART, and SPI tunnels are available.

The device is AEC-Q100 qualified.

Data can be transmitted over low-cost 50Ω Coax or 100Ω STP cables that meet the GMSL3 or GMSL2 channel specification. See [Table 1](#) for typical maximum cable lengths. Contact the factory for the GMSL3 or GMSL2 channel specifications.

**Table 1. Typical Maximum Cable Length vs. Attenuation**

|   | 3.2mm Ø<br>50Ω Coax,<br>Foam<br>Dielectric       | 2.7mm Ø<br>50Ω Coax,<br>Solid<br>Dielectric | 100Ω<br>Shielded<br>Twisted<br>Pair,<br>AWG26 |
|---|--|---|---|
| <b>Attenuation at 3GHz<br/>(Typ, Room Temp)</b>   | 0.9dB/m  | 1.6dB/m                                     | 1.8dB/m                                       |
| <b>Attenuation at 3GHz<br/>(Max, Aged, 105°C)</b> | 1.1dB/m  | 2.0dB/m                                     | 2.2dB/m                                       |
| <b>GMSL Fwd/Rev Data<br/>Rate</b>                 | <b>Typical Maximum Cable Length at<br/>105°C</b> |   |   |
| 3Gbps/187.5Mbps                                   | 20m  | 10m   | 11m   |
| 6Gbps/187.5Mbps                                   | 15m  | 9m  | 8m  |
| 12Gbps/187.5Mbps                                  | 14m  | 8m  | 7m  |

## Applications

- 8MP~15MP Forward-Vision Camera Systems (FVC)
- Aggregated Camera Data Forwarding
- eMirror Camera Systems (DMS)

## Benefits and Features

- Automotive Grade High-Speed Link
  - -18dB at 3GHz (12Gbps) Maximum Insertion Loss
  - Auto Adapt for Changes in Channel Conditions
  - Operates -40°C to +105°C Ambient
- Two MIPI CSI-2 v1.3 Output Ports
  - 2 x 4-Lane D-PHY v1.2 Rated at 2.5Gbps/Lane
  - 2 x 2-Lane C-PHY v1.0 Rated at 4.57Gbps/Lane
  - Supports 16 Virtual Channels
- Dual GMSL3 Inputs
  - 12Gbps GMSL3 Forward-Link Rate
  - GMSL2 Backward-Compatible 6Gbps/3Gbps Link Rates
  - 187.5Mbps Reverse-Link Rate
- Supports Tunneling and Pixel-Mode Video Transport
- Bidirectional Control-Channel Supports
  - 11 Configurable GPIO
  - 1 x I<sup>2</sup>C/UART Port up to 1MHz
  - 2x Pass-Through Ports
  - Up to 2M Baud as UART
  - Up to 1Mbps as I<sup>2</sup>C
  - 1x SPI Port, up to 25MHz
- Reduces BOM and Space Savings
  - 48-Pin 7mm x 7mm Side-Wettable TQFN
  - Reference-over-Reverse (RoR) Channel Clocking for Crystal-Free Operation on Serializers
  - Industry's Smallest Power-over-Coax (PoC)
- Safety-Ready
  - ASIL-B Compliant

[Ordering Information](#) appears at end of data sheet.

Simplified Application Circuit

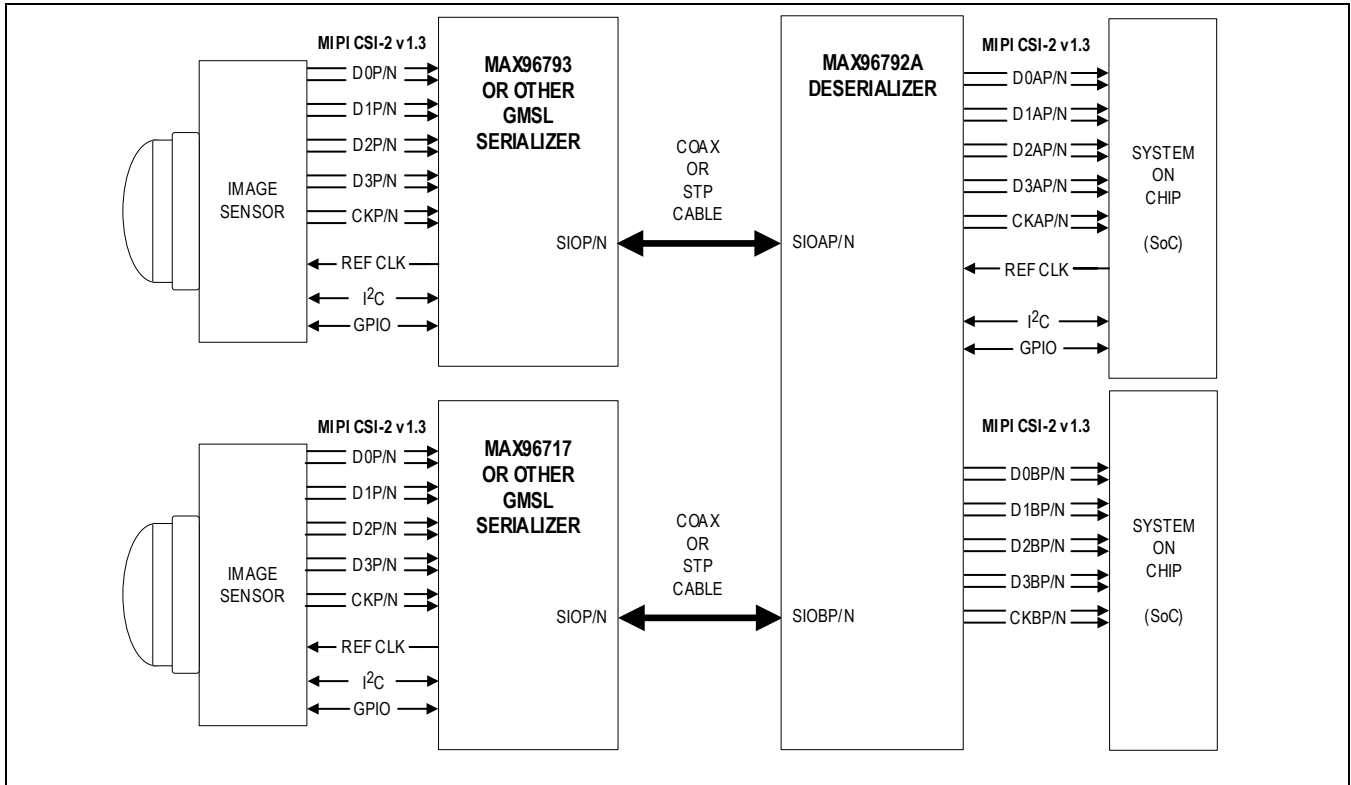

---

**TABLE OF CONTENTS**

---

|  |    |
|--|----|
| General Description .....                                | 1  |
| Applications.....  | 1  |
| Benefits and Features.....                               | 1  |
| Simplified Application Circuit.....                      | 2  |
| Absolute Maximum Ratings .....                           | 10 |
| Package Information .....                                | 10 |
| 48-Pin TQFN-SW.....                                      | 10 |
| Electrical Characteristics.....                          | 11 |
| Typical Operating Characteristics .....                  | 21 |
| Pin Configuration .....                                  | 23 |
| Pin Descriptions .....                                   | 23 |
| Functional Block Diagram .....                           | 27 |
| Block Diagram .....                                      | 27 |
| Configuration Pin Connections.....                       | 28 |
| Detailed Description .....                               | 28 |
| Additional Documentation .....                           | 28 |
| Recommended Operating Conditions .....                   | 29 |
| External Component Requirements .....                    | 29 |
| ESD Protection.....                                      | 30 |
| Functional Diagrams .....                                | 31 |
| Introduction.....  | 35 |
| Product Overview .....                                   | 36 |
| GMSL3 Overview.....                                      | 37 |
| Link Error Generator .....                               | 38 |
| Video Pipeline in Pixel Mode .....                       | 38 |
| Watermarking .....                                       | 38 |
| Video (Data) Line CRC .....                              | 38 |
| Vertical and Data Enable or Data Valid Sync Outputs..... | 38 |
| Control-Channel and Side Channels .....                  | 39 |
| Primary I <sup>2</sup> C/UART.....                       | 39 |
| I <sup>2</sup> C/UART CRC and Message Counter.....       | 39 |
| Pass-Through I <sup>2</sup> C/UART.....                  | 39 |
| Serial Peripheral Interface (SPI) .....                  | 40 |
| General Purpose Input and Output (GPIO) .....            | 40 |
| Delay in Non-Delay-Compensated Mode .....                | 41 |
| Delay-Compensated Mode .....                             | 41 |
| Frame-Sync .....   | 41 |

|  |    |
|--|----|
| Control-Channel Retransmission on Error .....                | 41 |
| Automatic Repeat Request/Automatic Retransmission (ARQ)..... | 41 |
| Other Functions .....  | 42 |
| Tunnel and Pixel Modes .....                                 | 42 |
| Forward-Error Correction (FEC) .....                         | 43 |
| Functional Safety Features .....                             | 43 |
| GMSL3 Physical Layer .....                                   | 44 |
| Cabling Options .....  | 44 |
| GMSL3 Bandwidth Sharing .....                                | 44 |
| GMSL3 Bandwidth Calculations .....                           | 44 |
| Eye-Opening Monitor (EOM) .....                              | 46 |
| Line-Fault .....   | 46 |
| Coax Mode .....  | 47 |
| STP Mode .....   | 47 |
| Adaptive Equalization (AEQ) .....                            | 48 |
| Video Pipes .....  | 48 |
| Video-Timing Generator (VTG) .....                           | 50 |
| RGB888 Video-Pattern Generator .....                         | 50 |
| Pseudorandom Binary Sequence (PRBS) .....                    | 50 |
| Video PRBS .....   | 50 |
| Link PRBS .....  | 50 |
| Video-Memory ECC Protection .....                            | 51 |
| Scheduler/Arbiter .....                                      | 51 |
| Control-Channel CRC Generation and Checking.....             | 51 |
| Serial Peripheral Interface (SPI).....                       | 52 |
| CSI-2 Output Interface .....                                 | 52 |
| Lane Configurations and Data Rates.....                      | 52 |
| CSI-2 Virtual Channel and Data Type Interleaving.....        | 52 |
| Video PRBS Generator/Checker .....                           | 52 |
| MIPI CSI-2 Output Raw PRBS Generator .....                   | 53 |
| Lane Deskew .....  | 53 |
| Minimum Blanking .....                                       | 53 |
| MIPI End-to-End Packet Spacing .....                         | 54 |
| CFG Latch at Power-Up Pins .....                             | 54 |
| MFP Function Map and Slew Settings .....                     | 55 |
| MFP Pin Equivalent Circuits .....                            | 57 |
| Power-Up and Link Start-Up .....                             | 58 |
| Device Reset .....   | 58 |

|   |    |
|---|----|
| Link and Video Lock .....   | 59 |
| Link Lock.....  | 59 |
| Video Lock .....  | 60 |
| Error and Fault-Condition Monitoring .....  | 60 |
| Clocking.....   | 60 |
| Spread-Spectrum Clocking .....  | 60 |
| Power Supplies .....  | 60 |
| Power Standby and Sleep Mode .....  | 61 |
| PCB Layout Guidelines for GMSL.....   | 61 |
| Ground Plane.....   | 61 |
| High-Speed GMSL Traces.....   | 62 |
| Power-Over-Coax (PoC) Layout.....   | 62 |
| Shielded Twisted-Pair (STP) Layout.....   | 63 |
| Thermal Management.....   | 63 |
| Applications Information.....   | 64 |
| Software Programming Model.....   | 64 |
| Programming Notes .....   | 64 |
| Mandatory Register Programming .....  | 64 |
| Primary I <sup>2</sup> C/UART Tunnel .....  | 64 |
| Control-Channel Programming.....  | 64 |
| Conventional I <sup>2</sup> C/UART Control-Channel Programming .....                              | 64 |
| Host-to-Peripheral Primary I <sup>2</sup> C and Pass-Through I <sup>2</sup> C Communication ..... | 64 |
| I <sup>2</sup> C Write Packet Format .....  | 65 |
| I <sup>2</sup> C Read Packet Format .....   | 65 |
| Primary I <sup>2</sup> C Host-to-GMSL2 Device Communication.....                                  | 65 |
| Main UART .....   | 65 |
| UART Base Mode.....   | 65 |
| UART Bypass Mode .....  | 65 |
| Switching Between UART Base and Bypass Modes .....  | 66 |
| UART Frame Format .....   | 66 |
| Synchronization Frame.....  | 66 |
| Acknowledge Frame .....   | 67 |
| Write Packet .....  | 67 |
| Read Packet .....   | 67 |
| I <sup>2</sup> C/UART Control-Channel Programming with Optional CRC and Message Counter .....     | 67 |
| I <sup>2</sup> C/UART CRC and Message Counter Options.....  | 67 |
| I <sup>2</sup> C Writes with CRC.....   | 67 |
| I <sup>2</sup> C Reads with CRC .....   | 68 |

Message Counter Writes .....68

Message Counter Reads .....68

UART Writes with CRC.....69

UART Reads with CRC .....69

Typical Application Circuits .....71

Ordering Information .....71

Register Map.....72

    Reserved, Unused, and Read-Only Register Bits.....72

Revision History .....441

---

**LIST OF FIGURES**

---

|   |    |
|---|----|
| Figure 1. Configuration Pin Connection .....  | 28 |
| Figure 2. GMSL3 Reverse-Channel Serial Outputs .....  | 31 |
| Figure 3. Ideal Single-Ended and Resulting Differential High-Speed Signals .....                                      | 31 |
| Figure 4. Possible $\Delta V_{CMTX}$ and $\Delta V_{OD}$ Distortions of Single-Ended HS Signals.....                  | 31 |
| Figure 5. D-PHY Signaling Levels .....  | 32 |
| Figure 6. C-PHY DC Characteristics.....   | 32 |
| Figure 7. C-PHY Possible $\Delta V_{CPTX}$ and $\Delta V_{OD}$ Distortions of Single-Ended HS Signals .....           | 32 |
| Figure 8. C-PHY Ideal Single-Ended and Resulting Differential High-Speed Signals .....                                | 32 |
| Figure 9. GMSL3 Video Latency.....  | 33 |
| Figure 10. GPI-to-GPO Delay and Skew .....  | 33 |
| Figure 11. D-PHY High-Speed Data Transmission in Bursts.....  | 33 |
| Figure 12. D-PHY Data Clock Timing .....  | 33 |
| Figure 13. Switching the Clock Lane between Clock Transmission and Low-Power Mode .....                               | 34 |
| Figure 14. D-PHY High-Speed Skew Calibration.....   | 34 |
| Figure 15. C-PHY High-Speed Data Transmission in Bursts.....  | 34 |
| Figure 16. I <sup>2</sup> C Timing Parameters.....  | 34 |
| Figure 17. SPI Main-Mode Timing Parameters.....   | 35 |
| Figure 18. SPI Subordinate-Mode Timing Parameters .....   | 35 |
| Figure 19. Single Link .....  | 36 |
| Figure 20. Dual Link, Separate Data.....  | 36 |
| Figure 21. Dual Link, Data Aggregation .....  | 37 |
| Figure 22. Dual Link, Data Aggregation and Replication .....  | 37 |
| Figure 23. Pixel Mode .....   | 42 |
| Figure 24. Tunnel Mode.....   | 43 |
| Figure 25. Video Frame Format for Bandwidth Calculation .....   | 45 |
| Figure 26. Line Fault Detection Location Options.....   | 46 |
| Figure 27. Typical GMSL Link Application Circuit for Coax Cable.....  | 47 |
| Figure 28. Typical GMSL Link Application Circuit for Twisted Pair (Line-Fault Pair #1: LMN0 and LMN1, Option #2) .... | 48 |
| Figure 29. GMSL3 Video Output of Separate Ports.....  | 49 |
| Figure 30. GMSL3 Video Aggregated and Replicated .....  | 50 |
| Figure 31. SPI Bridge.....  | 52 |
| Figure 32. Video Timing .....   | 53 |
| Figure 33. End-to-End Packet Spacing.....   | 54 |
| Figure 34. Standard High-Speed GPIO .....   | 57 |
| Figure 35. Standard I <sup>2</sup> C GPIO .....   | 57 |
| Figure 36. GMSL3/2 Lock Time .....  | 59 |
| Figure 37. Coax PoC Layout Example.....   | 62 |
| Figure 38. STP Layout Example .....   | 63 |
| Figure 39. I <sup>2</sup> C Write Packet Format .....   | 65 |
| Figure 40. I <sup>2</sup> C Read Packet Format .....  | 65 |
| Figure 41. UART Protocol for Base Mode .....  | 65 |
| Figure 42. UART Data Format for Base Mode.....  | 66 |
| Figure 43. UART Synchronization Frame .....   | 66 |
| Figure 44. UART Acknowledge Frame .....   | 67 |
| Figure 45. UART Write Packet Format .....   | 67 |
| Figure 46. UART Read Packet Format.....   | 67 |
| Figure 47. I <sup>2</sup> C CRC Engine .....  | 68 |
| Figure 48. I <sup>2</sup> C Multiple-Byte Write with CRC.....   | 68 |
| Figure 49. I <sup>2</sup> C Single-Byte Write with CRC .....  | 68 |
| Figure 50. I <sup>2</sup> C Multiple-Byte Read with CRC .....   | 68 |
| Figure 51. I <sup>2</sup> C Single-Byte Read with CRC.....  | 68 |
| Figure 52. UART CRC Engine .....  | 69 |
| Figure 53. UART Multiple-Byte Write Transactions with CRC .....   | 69 |

Figure 54. UART Single-Byte Write Transaction with CRC .....69  
Figure 55. UART Multiple-Byte Read Transaction with CRC.....69  
Figure 56. UART Single-Byte Read Transaction with CRC .....70

---

**LIST OF TABLES**

---

|           |   |    |
|-----------|---|----|
| Table 1.  | Typical Maximum Cable Length vs. Attenuation.....                       | 1  |
| Table 2.  | Recommended Operating Conditions.....                                   | 29 |
| Table 3.  | External Component Requirements.....                                    | 29 |
| Table 4.  | ESD Protection .....  | 30 |
| Table 5.  | SPI Latching Edge and Speed.....  | 40 |
| Table 6.  | Typical GPIO Delays for Forward-Link and Reverse-Link Transmission..... | 41 |
| Table 7.  | Forward- and Reverse-Link Bandwidth Utilization .....                   | 45 |
| Table 8.  | Coax Mode Line-Fault Configuration Options.....                         | 47 |
| Table 9.  | STP Mode Line Fault Configuration Options for LMN0/LMN1 .....           | 47 |
| Table 10. | STP Mode Line-Fault Configuration Options for LMN2/LMN3 .....           | 47 |
| Table 11. | Video-Pattern Generator Pixel Clock Selection.....                      | 50 |
| Table 12. | CFG0 Input Map.....   | 54 |
| Table 13. | CFG1 Input Map.....   | 55 |
| Table 14. | MFP Pin Function Map.....   | 55 |
| Table 15. | Control- and Side-Channel Typical Rise and Fall Times.....              | 56 |

## Absolute Maximum Ratings

(All voltages with respect to ground)

|  |                 |   |                                     |
|--|-----------------|---|-------------------------------------|
| V <sub>DDIO</sub> .....                              | -0.3V to +3.9V  | SIO_ (Inactive State) ( <a href="#">Note 1</a> ) .....  | -0.3V to +1.1V                      |
| V <sub>DD18</sub> .....                              | -0.3V to +2.0V  | D-PHY, C-PHY Pins ( <a href="#">Note 2</a> ) .....  | -0.3V to (V <sub>TERM</sub> + 0.1V) |
| V <sub>DD</sub> .....                                | -0.3V to +2.0V  | XRES, X2 .....  | -0.3V to (V <sub>DD18</sub> + 0.3V) |
| V <sub>TERM</sub> .....                              | -0.3V to +1.32V | All Other Pins ( <a href="#">Note 3</a> ) .....   | -0.3V to (V <sub>DDIO</sub> + 0.3V) |
| CAP_VDD .....  | -0.3V to +1.2V  | Continuous Power Dissipation (Multilayer Board) (T <sub>A</sub> = +70°C, derate 40mW/°C above +70°C.) ..... | mW to 2200 mW                       |
| SIO_ (Active State) ( <a href="#">Note 1</a> ) ..... | +0.5V to +2.0V  | Storage Temperature Range .....   | -40°C to +150°C                     |
|  |                 | Soldering Temperature (Reflow) .....  | +260°C                              |

**Note 1:** Active state means device is powered-up, and not in sleep or power-down mode. Inactive means device is not powered-up, or powered-up in sleep or power-down mode.

**Note 2:** V<sub>TERM</sub> ≤ +1.26V.

**Note 3:** V<sub>DDIO</sub> = specified maximum voltage or 3.9V, whichever is lower.

Stresses beyond those listed under "Absolute Maximum Ratings" may cause permanent damage to the device. These are stress ratings only, and functional operation of the device at these or any other conditions beyond those indicated in the operational sections of the specifications is not implied. Exposure to absolute maximum rating conditions for extended periods may affect device reliability.

## Package Information

### 48-Pin TQFN-SW

|  |  |
|--|--|
| Package Code                                 | T4877Y ( <a href="#">Click on Land Pattern Number link below for additional details.</a> ) |
| Outline Number                               | <a href="#">21-100045</a>  |
| Land Pattern Number                          | <a href="#">90-100016</a>  |
| <b>Thermal Resistance, Four-Layer Board:</b> |  |
| Junction to Ambient (θ <sub>JA</sub> )       | 25°C/W   |
| Junction to Case (θ <sub>JC</sub> )          | 1°C/W  |

For the latest package outline information and land patterns (footprints), go to [www.analog.com/packages](http://www.analog.com/packages). Note that a "+", "#", or "-" in the package code indicates RoHS status only. Package drawings may show a different suffix character, but the drawing pertains to the package regardless of RoHS status.

Package thermal resistances were obtained using the method described in JEDEC specification JESD51-7, using a four-layer board in still air. For detailed information on package thermal considerations, refer to [www.analog.com/thermal-tutorial](http://www.analog.com/thermal-tutorial).

## Electrical Characteristics

( $V_{DD18} = 1.7V$  to  $1.9V$ ,  $V_{DD} = 0.95V$  to  $1.05V$  or  $V_{DD} = 1.14V$  to  $1.26V$ ,  $V_{DDIO} = 1.7V$  to  $3.6V$ ,  $V_{TERM} = 1.14$  to  $1.26V$ ,  $T_A = -40^\circ C$  to  $+105^\circ C$ , EP connected to PCB ground, typical values are at  $V_{DD18} = V_{DDIO} = 1.8V$ ,  $V_{DD} = 1.0V$ ,  $V_{TERM} = 1.2V$ ,  $T_A = 25^\circ C$ , unless otherwise noted. ([Note 4](#)))

| PARAMETER   | SYMBOL                   | CONDITIONS   |  | MIN               | TYP               | MAX               | UNITS    |
|---|--------------------------|--|--|-------------------|-------------------|-------------------|----------|
| <b>DC ELECTRICAL CHARACTERISTICS / GMSL3 REVERSE-CHANNEL SERIAL I/O (SIOAP, SIOAN, SIOBP, SIOBN)—SEE <a href="#">Figure 2</a></b> |                          |  |  |                   |                   |                   |          |
| Output-Voltage Swing (Single-Ended)   | $V_O$                    | GMSL2 mode   | $R_L = 100\Omega \pm 1\%$ ,<br>( $V_{OH} - V_{OL}$ ) for all outputs | 190               | 250               | 310               | mV       |
| Output-Voltage Swing (Differential)   | $V_{ODT}$                | GMSL2 mode   | $R_L = 100\Omega \pm 1\%$ ,<br>peak-to-peak differential voltage     | 380               | 500               | 620               | mV       |
| Output-Voltage Swing (Single-Ended)   | $V_O$                    | 12Gbps forward data rate (GMSL3 mode)  | $R_L = 100\Omega \pm 1\%$ ,<br>( $V_{OH} - V_{OL}$ ) for all outputs | 110               | 150               | 190               | mV       |
| Output-Voltage Swing (Differential)   | $V_{ODT}$                | 12Gbps forward data rate (GMSL3 mode)  | $R_L = 100\Omega \pm 1\%$ ,<br>peak-to-peak differential voltage     | 220               | 300               | 380               | mV       |
| Change in $V_{OD}$ Between Complementary Output States  | $\Delta V_{OD}$          | $R_L = 100\Omega \pm 1\%$ , $ V_{OD(H)} - V_{OD(L)} $                                    |  |                   |                   | 25                | mV       |
| Differential Output Offset Voltage  | $V_{OS}$                 | $R_L = 100\Omega \pm 1\%$ ,<br>offset voltage in each output state                       | GMSL2 mode   | $V_{DD18} - 0.45$ | $V_{DD18} - 0.3$  | $V_{DD18} - 0.15$ | V        |
|   |                          |  | GMSL3 mode   | $V_{DD18} - 0.4$  | $V_{DD18} - 0.25$ | $V_{DD18} - 0.1$  |          |
| Change in $V_{OS}$ Between Complimentary Output States  | $\Delta V_{OS}$          | $R_L = 100\Omega \pm 1\%$ , $ V_{OD(H)} - V_{OD(L)} $                                    |  |                   |                   | 25                | mV       |
| Output Termination Resistance (Internal)  | $R_T$                    | Any pin to $V_{DD18}$  |  | 50                | 55                | 60                | $\Omega$ |
| <b>DC ELECTRICAL CHARACTERISTICS / C-PHY AND D-PHY LP TRANSMITTER</b>   |                          |  |  |                   |                   |                   |          |
| High-Level Output Voltage   | $V_{OH}$                 | See <a href="#">Figure 5</a> , <a href="#">Figure 6</a>                                  |  | 0.95              | 1.2               | 1.3               | V        |
| Low-Level Output Voltage  | $V_{OL}$                 | See <a href="#">Figure 5</a> , <a href="#">Figure 6</a>                                  |  | -50               |                   | 50                | mV       |
| Output Impedance  | $Z_{OLP}$                | <a href="#">(Note 12)</a>  |  | 110               |                   |                   | $\Omega$ |
| <b>DC ELECTRICAL CHARACTERISTICS / D-PHY HS TRANSMITTER</b>   |                          |  |  |                   |                   |                   |          |
| HS Transmit Static Common-Mode Voltage  | $V_{CMTX}$               | See <a href="#">Figure 5</a>   |  | 150               | 200               | 250               | mV       |
| $V_{CMTX}$ Mismatch when Output is Differential-1 or Differential-0   | $ \Delta V_{CMTX(1,0)} $ | $\Delta V_{CMTX(1,0)} = (V_{CMTX(1)} - V_{CMTX(0)})/2$ ,<br>See <a href="#">Figure 4</a> |  |                   |                   | 5                 | mV       |
| HS Transmit Differential Voltage  | $ V_{OD} $               | See <a href="#">Figure 3</a>   |  | 140               | 200               | 270               | mV       |
| $V_{OD}$ Mismatch when Output is Differential-1 or Differential-0   | $ \Delta V_{OD} $        | See <a href="#">Figure 4</a>   |  |                   |                   | 14                | mV       |
| HS Output High Voltage  | $V_{OHHS}$               | See <a href="#">Figure 5</a>   |  |                   |                   | 360               | mV       |
| Single-Ended Output Impedance   | $Z_{OS}$                 |  |  | 40                | 50                | 62.5              | $\Omega$ |

( $V_{DD18} = 1.7V$  to  $1.9V$ ,  $V_{DD} = 0.95V$  to  $1.05V$  or  $V_{DD} = 1.14V$  to  $1.26V$ ,  $V_{DDIO} = 1.7V$  to  $3.6V$ ,  $V_{TERM} = 1.14$  to  $1.26V$ ,  $T_A = -40^\circ C$  to  $+105^\circ C$ , EP connected to PCB ground, typical values are at  $V_{DD18} = V_{DDIO} = 1.8V$ ,  $V_{DD} = 1.0V$ ,  $V_{TERM} = 1.2V$ ,  $T_A = 25^\circ C$ , unless otherwise noted. (Note 4))

| PARAMETER   | SYMBOL                     | CONDITIONS   | MIN              | TYP        | MAX              | UNITS      |
|---|----------------------------|--|------------------|------------|------------------|------------|
| Single-Ended Output Impedance Mismatch  | $\Delta Z_{OS}$            |  |                  |            | 10               | %          |
| <b>DC ELECTRICAL CHARACTERISTICS / C-PHY HS TRANSMITTER</b>   |                            |  |                  |            |                  |            |
| HS Transmit Static Common-Point Voltage   | $V_{CPTX}$                 | See <a href="#">Figure 6</a> , ( <a href="#">Note 7</a> , <a href="#">Note 9</a> ) | 175              | 225 to 250 | 310              | mV         |
| $V_{CPTX}$ Mismatch when Output is in any of the Six High-Speed States  | $ \Delta V_{CPTX(HS)} $    | See <a href="#">Figure 7</a>   |                  |            | 9                | mV         |
| HS Transmit Differential Voltage of the Differential Strong 1 and Strong 0  | $ \Delta V_{OD} _{strong}$ | See <a href="#">Figure 8</a> , ( <a href="#">Note 7</a> )                          |                  |            | 300              | mV         |
| HS Transmit Differential Voltage of the Differential Weak 1 and Weak 0  | $ \Delta V_{OD} _{weak}$   | See <a href="#">Figure 8</a> , ( <a href="#">Note 7</a> )                          | 97               |            |                  | mV         |
| $V_{OD}$ Mismatch Between the Absolute Values of the Differential Strong 1 and Strong 0 Output Voltage is any of the Six Possible High-Speed States | $ \Delta V_{OD} $          | See <a href="#">Figure 7</a>   |                  |            | 17               | mV         |
| HS Output High Voltage  | $V_{OHHS}$                 | See <a href="#">Figure 6</a> , ( <a href="#">Note 7</a> )                          |                  |            | 425              | mV         |
| Single-Ended Output Impedance   | $Z_{OS}$                   |  | 40               | 50         | 60               | $\Omega$   |
| Single-Ended Output Impedance Mismatch  | $\Delta Z_{OS}$            |  |                  |            | 10               | %          |
| <b>DC ELECTRICAL CHARACTERISTICS / I/O PINS (GPIO)</b>  |                            |  |                  |            |                  |            |
| High-Level Input Voltage  | $V_{IH}$                   |  | 0.7 x $V_{DDIO}$ |            |                  | V          |
| Low-Level Input Voltage   | $V_{IL}$                   |  |                  |            | 0.3 x $V_{DDIO}$ | V          |
| High-Level Output Voltage   | $V_{OH}$                   | $I_{OH} = -4mA$  | $V_{DDIO} - 0.4$ |            |                  | V          |
| Low-Level Output Voltage  | $V_{OL}$                   | $I_{OL} = 4mA$   |                  |            | 0.4              | V          |
| Input Current   | $I_{IN}$                   | $V_{IN} = 0$ to $V_{DDIO}$ . All pull-up/pull-down devices disabled.               |                  |            | 1                | $\mu A$    |
| Input Capacitance   | $C_{IN}$                   |  | 5                |            |                  | pF         |
| Input Pull-Up/Pull-Down Resistance  | $R_{IN}$                   | 40k $\Omega$ enabled   | 40               |            |                  | k $\Omega$ |
|   |                            | 1M $\Omega$ enabled  | 1                |            |                  | M $\Omega$ |
| <b>DC ELECTRICAL CHARACTERISTICS / OPEN-DRAIN PINS (SDA_, SCL_, SDA_RX, TX_SCL, LOCK, ERRB/LFLTb, ODO)</b>  |                            |  |                  |            |                  |            |
| High-Level Input Voltage  | $V_{IH}$                   |  | 0.7 x $V_{DDIO}$ |            |                  | V          |
| Low-Level Input Voltage   | $V_{IL}$                   |  |                  |            | 0.3 x $V_{DDIO}$ | V          |
| Low-Level Open-Drain Output Voltage   | $V_{OL}$                   | $I_{OL} = 4mA$   |                  |            | 0.4              | V          |

( $V_{DD18} = 1.7V$  to  $1.9V$ ,  $V_{DD} = 0.95V$  to  $1.05V$  or  $V_{DD} = 1.14V$  to  $1.26V$ ,  $V_{DDIO} = 1.7V$  to  $3.6V$ ,  $V_{TERM} = 1.14$  to  $1.26V$ ,  $T_A = -40^\circ C$  to  $+105^\circ C$ , EP connected to PCB ground, typical values are at  $V_{DD18} = V_{DDIO} = 1.8V$ ,  $V_{DD} = 1.0V$ ,  $V_{TERM} = 1.2V$ ,  $T_A = 25^\circ C$ , unless otherwise noted. ([Note 4](#)))

| PARAMETER  | SYMBOL       | CONDITIONS   | MIN                   | TYP  | MAX                   | UNITS       |
|--|--------------|--|-----------------------|------|-----------------------|-------------|
| Input Current  | $I_{IN}$     | $V_{IN} = 0$ to $V_{DDIO}$ . All pull-up/pull-down devices disabled. |                       |      | 1                     | $\mu A$     |
| Input Capacitance  | $C_{IN}$     |  |                       | 3    |                       | pF          |
| Internal Pull-Up Resistor  | $R_{PU}$     | 40k $\Omega$ enabled   |                       | 40   |                       | k $\Omega$  |
|  |              | 1M $\Omega$ enabled  |                       | 1    |                       | M $\Omega$  |
| <b>DC ELECTRICAL CHARACTERISTICS / PWDNB INPUT</b>   |              |  |                       |      |                       |             |
| High-Level Input Voltage   | $V_{IH}$     |  | $0.7 \times V_{DDIO}$ |      |                       | V           |
| Low-Level Input Voltage  | $V_{IL}$     |  |                       |      | $0.3 \times V_{DDIO}$ | V           |
| Input Current  | $I_{IN}$     | $V_{IN} = 0$ to $V_{DDIO}$   |                       |      | 6                     | $\mu A$     |
| Internal Pull-Down Resistance  | $R_{PD}$     |  |                       | 1    |                       | M $\Omega$  |
| Input Capacitance  | $C_{IN}$     |  |                       | 3    |                       | pF          |
| <b>DC ELECTRICAL CHARACTERISTICS / PUSH-PULL OUTPUTS</b>   |              |  |                       |      |                       |             |
| High-Level Output Voltage  | $V_{OH}$     | $I_{OH} = -4mA$  | $V_{DDIO} - 0.4$      |      |                       | V           |
| Low-Level Output Voltage   | $V_{OL}$     | $I_{OL} = 4mA$   |                       |      | 0.4                   | V           |
| <b>DC ELECTRICAL CHARACTERISTICS / LINE FAULT DETECTION, (See <a href="#">Figure 26</a>, <a href="#">Figure 28</a>)</b>  |              |  |                       |      |                       |             |
| Open Pin Voltage   | $V_{O0}$     | LMN0, LMN2   |                       | 1.25 |                       | V           |
|  | $V_{O1}$     | LMN1, LMN3   |                       | 0.75 |                       |             |
| <b>DC ELECTRICAL CHARACTERISTICS / REFERENCE CLOCK INPUT REQUIREMENTS (CRYSTAL), (X1/OSC, X2)</b>                        |              |  |                       |      |                       |             |
| X1 Input Capacitance   | $C_{IN\_X1}$ |  |                       | 3    |                       | pF          |
| X2 Input Capacitance   | $C_{IN\_X2}$ |  |                       | 1    |                       | pF          |
| X2 Limit Resistor  | $R_{LIM}$    |  |                       | 1.2  |                       | k $\Omega$  |
| Feedback Resistor  | $R_{FB}$     |  |                       | 10   |                       | k $\Omega$  |
| Transconductance   | $g_m$        |  |                       | 28   |                       | mA/V        |
| <b>DC ELECTRICAL CHARACTERISTICS / REFERENCE CLOCK INPUT REQUIREMENTS (X1/OSC DRIVEN BY EXTERNAL CLOCK, X2 FLOATING)</b> |              |  |                       |      |                       |             |
| High-Level Input Voltage   | $V_{IH}$     |  | 0.9                   |      |                       | V           |
| Low-Level Input Voltage  | $V_{IL}$     |  |                       |      | 0.4                   | V           |
| X1 Input Capacitance   | $C_{IN\_X1}$ |  |                       | 3    |                       | pF          |
| Input Resistance   | $R_{IN}$     |  |                       | 10   |                       | k $\Omega$  |
| <b>DC ELECTRICAL CHARACTERISTICS / POWER SUPPLY CURRENTS</b>   |              |  |                       |      |                       |             |
| Supply Current   | $I_{DD}$     | 2x 12Gbps input, 2x 4-lane output, 2.5Gbps/lane                      | $V_{DD} = 1.05V$      | 365  | 850                   | mA          |
|  |              |  | $V_{DD} = 1.26V$      | 365  | 850                   |             |
|  |              |  | $V_{DD18} = 1.9V$     | 210  | 250                   |             |
|  |              |  | $V_{TERM} = 1.26V$    | 31   | 40                    |             |
|  | $I_{DDIO}$   |  | $V_{DDIO} = 1.9V$     | 44   |                       | $\mu A/MHz$ |

( $V_{DD18} = 1.7V$  to  $1.9V$ ,  $V_{DD} = 0.95V$  to  $1.05V$  or  $V_{DD} = 1.14V$  to  $1.26V$ ,  $V_{DDIO} = 1.7V$  to  $3.6V$ ,  $V_{TERM} = 1.14$  to  $1.26V$ ,  $T_A = -40^\circ C$  to  $+105^\circ C$ , EP connected to PCB ground, typical values are at  $V_{DD18} = V_{DDIO} = 1.8V$ ,  $V_{DD} = 1.0V$ ,  $V_{TERM} = 1.2V$ ,  $T_A = 25^\circ C$ , unless otherwise noted. ([Note 4](#)))

| PARAMETER   | SYMBOL               | CONDITIONS  |                      | MIN | TYP  | MAX | UNITS    |
|---|----------------------|---|----------------------|-----|--|-----|----------|
| Maximum $V_{DDIO}$ Supply Current ( <a href="#">Note 8</a> )  |                      | Per toggling GPIO,<br>$C_L = 20pF$  | $V_{DDIO} = 3.6V$    |     | 81   |     |          |
| <b>DC ELECTRICAL CHARACTERISTICS / POWER-DOWN CURRENT</b>   |                      |   |                      |     |  |     |          |
| Maximum Power-Down Current  | $I_{DD}$             | $V_{DDIO}$ at 3.6V  | $T_A = +25^\circ C$  |     | 6  |     | $\mu A$  |
|   |                      |   | $T_A = +105^\circ C$ |     | 7  |     |          |
|   |                      | $V_{TERM}$ at 1.26V   | $T_A = +25^\circ C$  |     | < 1  |     |          |
|   |                      |   | $T_A = +105^\circ C$ |     | < 1  |     |          |
|   |                      | $V_{DD18}$ at 1.9V  | $T_A = +25^\circ C$  |     | < 1  |     |          |
|   |                      |   | $T_A = +105^\circ C$ |     | 28   |     |          |
| $V_{DD}$ at 1.26V   | $T_A = +25^\circ C$  |   | 6                    |     |  |     |          |
|   | $T_A = +105^\circ C$ |   | 6                    |     |  |     |          |
| <b>DC ELECTRICAL CHARACTERISTICS / SLEEP CURRENT</b>  |                      |   |                      |     |  |     |          |
| Maximum Sleep Current   | $I_{DD}$             | $V_{DDIO}$ at 3.6V  | $T_A = +25^\circ C$  |     | 9  |     | $\mu A$  |
|   |                      |   | $T_A = +105^\circ C$ |     | 9  |     |          |
|   |                      | $V_{TERM}$ at 1.26V   | $T_A = +25^\circ C$  |     | < 1  |     |          |
|   |                      |   | $T_A = +105^\circ C$ |     | < 1  |     |          |
|   |                      | $V_{DD18}$ at 1.9V  | $T_A = +25^\circ C$  |     | 17   |     |          |
|   |                      |   | $T_A = +105^\circ C$ |     | 47   |     |          |
| $V_{DD}$ at 1.26V   | $T_A = +25^\circ C$  |   | 7                    |     |  |     |          |
|   | $T_A = +105^\circ C$ |   | 6                    |     |  |     |          |
| <b>AC ELECTRICAL CHARACTERISTICS / GMSL3 FORWARD-CHANNEL SWITCHING CHARACTERISTICS</b>                              |                      |   |                      |     |  |     |          |
| Lock Time   | $t_{LOCK}$           | From power-up, one-shot reset, or rising edge of PWDNB to rising edge of LOCK. See <a href="#">Figure 36</a>                    |                      |     | 68   |     | ms       |
| Maximum Video Initialization Time   | $t_{VIDEOSTART}$     | Time from GMSL3 video packets at SIO_ to valid packets at the CSI-2 output (assumes link locked and registers configured).      |                      |     | $0.1 + (6600 \times T_{PCLK})$                 |     | ms       |
| Maximum Video Latency   | $t_{VL}$             | Time from the first pixel in a GMSL3 packet at SIO_ to the first pixel in the CSI-2 output packet. See <a href="#">Figure 9</a> |                      |     | $1 \text{ video line} + (128 \times T_{PCLK})$ |     | s        |
| PWDNB Hold Time   | $t_{HOLD\_PWDNB}$    | The minimum duration PWDNB must be held LOW to reset the chip.  |                      |     | 1  |     | ms       |
| <b>AC ELECTRICAL CHARACTERISTICS / GMSL3 REVERSE CHANNEL SERIAL OUTPUTS (SIO_P, SIO_N) (<a href="#">Note 5</a>)</b> |                      |   |                      |     |  |     |          |
| Serial Output Rise Time   | $t_R$                | 20% to 80%, $V_O = 250mV$ , $R_L = 100\Omega$   |                      |     | 2300   |     | ps       |
| Serial Output Fall Time   | $t_F$                | 80% to 20%, $V_O = 250mV$ , $R_L = 100\Omega$   |                      |     | 2300   |     | ps       |
| Total Serial Output Jitter  | $t_{TSOJ}$           | PRBS7, single-ended or differential output  |                      |     | 0.15   |     | UI (p-p) |
| Deterministic Serial Output Jitter  | $t_{DSOJ}$           | PRBS7, single-ended or differential output  |                      |     | 0.1  |     | UI (p-p) |
|   | $t_{GPDR}$           | Delay-compensated mode  |                      |     | 15   |     | $\mu s$  |

( $V_{DD18} = 1.7V$  to  $1.9V$ ,  $V_{DD} = 0.95V$  to  $1.05V$  or  $V_{DD} = 1.14V$  to  $1.26V$ ,  $V_{DDIO} = 1.7V$  to  $3.6V$ ,  $V_{TERM} = 1.14$  to  $1.26V$ ,  $T_A = -40^\circ C$  to  $+105^\circ C$ , EP connected to PCB ground, typical values are at  $V_{DD18} = V_{DDIO} = 1.8V$ ,  $V_{DD} = 1.0V$ ,  $V_{TERM} = 1.2V$ ,  $T_A = 25^\circ C$ , unless otherwise noted. ([Note 4](#)))

| PARAMETER   | SYMBOL                    | CONDITIONS  | MIN   | TYP            | MAX  | UNITS              |
|---|---------------------------|---|-------|----------------|------|--------------------|
| GPI-GPO Delay Reverse Path  |                           | See <a href="#">Figure 10</a>   |       | 6              |      |                    |
| GPI-GPO Skew Reverse Path   | $t_{SKEW}$                | Delay-compensated mode<br>See <a href="#">Figure 10</a>                               |       | 7              |      | ns                 |
| <b>AC ELECTRICAL CHARACTERISTICS / CSI-2 HS TRANSMITTER, CONFIGURED AS D-PHY</b>  |                           |   |       |                |      |                    |
| Common-Level Variations, HF   | $\Delta V_{CMTX(HF)}$     | > 450MHz, See <a href="#">Figure 4 (Note 5)</a>                                       |       |                | 15   | mV <sub>RMS</sub>  |
| Common-Level Variations, LF   | $\Delta V_{CMTX(LF)}$     | 50MHz to 450MHz, See <a href="#">Figure 4 (Note 5)</a>                                |       |                | 25   | mV <sub>PEAK</sub> |
| 20% to 80% Rise Time and Fall Time  | $t_R$ and $t_F$           | <a href="#">(Note 5)</a>  |       |                | 0.4  | UI                 |
|   |                           |   | 50    |                |      | ps                 |
| Tx Differential Return Loss   | $S_{ddTX}$                | $f_{MAX} = 1.0GHz$<br>$f_{MAX} = 1.5GHz$  |       | -10            |      | dB                 |
|   |                           |   |       | -8             |      |                    |
| Tx Common Mode Return Loss  | $S_{ccTX}$                | $f_{MAX} = 1.5GHz$  |       | -7             |      | dB                 |
| Data-Lane Bit Rate  | $D_{LBR}$                 |   | 80    |                | 2500 | Mbps               |
| Clock-Lane Frequency  | $C_{LFREQ}$               |   | 40    |                | 1250 | MHz                |
| CSI-2 Output Inter Packet Spacing   | $t_{SPACE}$               |   |       | 300 +<br>370UI |      | ns                 |
| <b>AC ELECTRICAL CHARACTERISTICS / D-PHY AND C-PHY LP TRANSMITTER (<a href="#">Note 5</a>)</b>                                  |                           |   |       |                |      |                    |
| 15% to 85% Fall Time  | $t_{FLP}$                 | <a href="#">(Note 6)</a>  |       |                | 25   | ns                 |
| 30% to 85% Rise Time  | $t_{REOT}$                | See <a href="#">Figure 11</a> , <a href="#">Figure 15</a> , <a href="#">(Note 11)</a> |       |                | 35   | ns                 |
| Load Capacitance  | $C_{LOAD}$                | <a href="#">(Note 6)</a>  | 0     |                | 70   | pF                 |
| <b>AC ELECTRICAL CHARACTERISTICS / D-PHY DATA-CLOCK TIMING (<a href="#">Note 5</a>)</b>   |                           |   |       |                |      |                    |
| UI Instantaneous  | $U_{INST}$                |   | 0.4   |                | 12.5 | ns                 |
| UI Variation  | $\Delta UI$               | $UI \geq 1ns$ , within a single burst   | -10%  |                | 10%  | UI                 |
|   |                           | $0.667ns < UI < 1ns$ , within a single burst  | -5%   |                | 5%   |                    |
| Data to Clock Skew  | $t_{SKEW}$                | 0.08Gbps to 1.0Gbps, See <a href="#">Figure 12</a>                                    | -0.15 |                | 0.15 | $U_{INST}$         |
|   |                           | > 1.0Gbps to 1.5Gbps, See <a href="#">Figure 12</a>                                   | -0.20 |                | 0.20 |                    |
| Static Data to Clock Skew (Tx)  | $t_{SKEW(TX)}$<br>Static  | > 1.5Gbps, See <a href="#">Figure 12</a>  | -0.20 |                | 0.20 | $U_{INST}$         |
| Dynamic Data to Clock Skew (Tx)   | $t_{SKEW(TX)}$<br>Dynamic | > 1.5Gbps, See <a href="#">Figure 12</a>  | -0.15 |                | 0.15 | $U_{INST}$         |
| <b>AC ELECTRICAL CHARACTERISTICS / CSI-2 D-PHY GLOBAL OPERATION TIMING (<a href="#">Note 5</a>)</b>                             |                           |   |       |                |      |                    |
| Time the Transmitter Drives the HS Clock Before any Associated Data Lane Beginning the Transition from LP Mode to HS Mode       | $t_{CLK-PRE}$             | See <a href="#">Figure 13</a>   |       | 8              |      | $U_{INST}$         |
| Time the Transmitter Drives the Clock Lane LP-00 Line State Immediately Before the HS-0 Line State Starting the HS Transmission | $t_{CLK-PREPARE}$         | See <a href="#">Figure 13</a>   |       | 38             | 95   | ns                 |

( $V_{DD18} = 1.7V$  to  $1.9V$ ,  $V_{DD} = 0.95V$  to  $1.05V$  or  $V_{DD} = 1.14V$  to  $1.26V$ ,  $V_{DDIO} = 1.7V$  to  $3.6V$ ,  $V_{TERM} = 1.14$  to  $1.26V$ ,  $T_A = -40^{\circ}C$  to  $+105^{\circ}C$ , EP connected to PCB ground, typical values are at  $V_{DD18} = V_{DDIO} = 1.8V$ ,  $V_{DD} = 1.0V$ ,  $V_{TERM} = 1.2V$ ,  $T_A = 25^{\circ}C$ , unless otherwise noted. ([Note 4](#)))

| PARAMETER   | SYMBOL                           | CONDITIONS  | MIN                  | TYP | MAX                  | UNITS              |
|---|----------------------------------|---|----------------------|-----|----------------------|--------------------|
| $T_{CLK-PREPARE}$ + Time the Transmitter Drives the HS-0 State Before Starting the Clock  | $t_{CLK-PREPARE} + t_{CLK-ZERO}$ | See <a href="#">Figure 13</a>   | 300                  |     |                      | ns                 |
| Transmitted Time Interval from the Start of $T_{HS-TRAIL}$ or $T_{CLK-TRAIL}$ , to the Start of the LP-11 State Following an HS Burst | $t_{EOT}$                        | See <a href="#">Figure 11</a> , <a href="#">Figure 13</a> , and <a href="#">Figure 14</a> |                      |     | $105 + 12 \times UI$ | ns                 |
| Time the Transmitter Drives LP-11 Following an HS Burst   | $t_{HS-EXIT}$                    | See <a href="#">Figure 11</a> , <a href="#">Figure 13</a> , and <a href="#">Figure 14</a> | 100                  |     |                      | ns                 |
| Time the Transmitter Drives the Data Lane LP-00 Line State Immediately Before the HS-0 Line State Starting the HS Transmission        | $t_{HS-PREPARE}$                 | See <a href="#">Figure 11</a> , <a href="#">Figure 13</a> , and <a href="#">Figure 14</a> | $40 + 4 \times UI$   |     | $85 + 6 \times UI$   | ns                 |
| $T_{HS-PREPARE}$ + Time the Transmitter Drives the HS-0 State Before Transmitting the Sync Sequence                                   | $t_{HS-PREPARE} + T_{HS-ZERO}$   | See <a href="#">Figure 11</a>   | $145 + 10 \times UI$ |     |                      | ns                 |
| Time the Transmitter Drives the Flipped Differential State After Last Payload Data Bit of an HS Transmission Burst                    | $t_{HS-TRAIL}$                   | See <a href="#">Figure 11</a> , <a href="#">Figure 14</a>                                 | $60 + 4 \times UI$   |     |                      | ns                 |
| Initialization  | $t_{INIT}$                       |   | 100                  |     |                      | $\mu s$            |
| Transmitted Length of Any Low-Power State Period  | $t_{LPX}$                        | See <a href="#">Figure 11</a> , <a href="#">Figure 13</a> , and <a href="#">Figure 14</a> | 50                   |     |                      | ns                 |
| Time the Transmitter Drives the Skew-Calibration Sync Pattern, 0xFFFF   | $t_{SKEWCAL\_SYNC}$              | See <a href="#">Figure 14</a>   |                      | 16  |                      | UI                 |
| Time the Transmitter Drives the Skew-Calibration Pattern in the Initial Skew-Calibration Mode   | $t_{SKEWCAL}$                    | See <a href="#">Figure 14</a>   |                      |     | 100                  | $\mu s$            |
|   |                                  |   | $2^{15}$             |     |                      | UI                 |
| Time the Transmitter Drives the Skew-Calibration Pattern in the Periodic Skew-Calibration Mode.                                       | $T_{SKEWCAL}$                    | See <a href="#">Figure 14</a>   |                      |     | 10                   | $\mu s$            |
|   |                                  |   | $2^{10}$             |     |                      | UI                 |
| <b>AC ELECTRICAL CHARACTERISTICS / CSI-2 HS TRANSMITTER, CONFIGURED AS C-PHY</b>  |                                  |   |                      |     |                      |                    |
| Common-Level Variations ( <a href="#">Note 5</a> )  | $\Delta V_{CPTX(HF)}$            | > 450MHz  |                      |     | 15                   | mV <sub>RMS</sub>  |
|   | $\Delta V_{CPTX(LF)}$            | 50MHz to 450MHz   |                      |     | 25                   | mV <sub>PEAK</sub> |

( $V_{DD18} = 1.7V$  to  $1.9V$ ,  $V_{DD} = 0.95V$  to  $1.05V$  or  $V_{DD} = 1.14V$  to  $1.26V$ ,  $V_{DDIO} = 1.7V$  to  $3.6V$ ,  $V_{TERM} = 1.14$  to  $1.26V$ ,  $T_A = -40^\circ C$  to  $+105^\circ C$ , EP connected to PCB ground, typical values are at  $V_{DD18} = V_{DDIO} = 1.8V$ ,  $V_{DD} = 1.0V$ ,  $V_{TERM} = 1.2V$ ,  $T_A = 25^\circ C$ , unless otherwise noted. ([Note 4](#)))

| PARAMETER  | SYMBOL              | CONDITIONS  | MIN   | TYP                          | MAX   | UNITS   |
|--|---------------------|---|-------|------------------------------|-------|---------|
| Rise Time  | $t_R$               | Strong 0 to weak 1 transition, $-58mV$ to $+58mV$ , $Z_{ID} = 100\Omega$ ( <a href="#">Note 5</a> )   |       |                              | 0.285 | UI      |
| Fall time  | $t_F$               | Strong 1 to weak 0 transition, $+58mV$ to $-58mV$ , $Z_{ID} = 100\Omega$ ( <a href="#">Note 5</a> )   |       |                              | 0.285 | UI      |
| Rise Time and Fall Time Limit  | $t_{RISE-FALL-MAX}$ | $-58mV$ to $+58mV$ , $Z_{ID} = 100\Omega$ ( <a href="#">Note 5</a> , <a href="#">Note 10</a> )  |       |                              | 360   | ps      |
| Differential-Mode Reflection Coefficient ( <a href="#">Note 13</a> )   | $S_{ddTX}$          | $f_h = 1.25GHz$   |       | -12                          |       | dB      |
|  |                     | $f_{MAX} = 1.875GHz$  |       | -9                           |       |         |
| Common-Mode Reflection Coefficient ( <a href="#">Note 13</a> )   | $S_{ccTX}$          | $f_{MAX} = 1.875GHz$  |       | -10                          |       | dB      |
| C-PHY Lane Bit Rate  | $C_{BR}$            |   | 182   |                              | 4571  | Mbps    |
| CSI-2 Output Inter-Packet Spacing  | $t_{SPACE}$         |   |       | 300 +<br>370 x UI            |       | ns      |
| UI Instantaneous   | $UI_{INST}$         |   | 0.4   |                              | 12.5  | ns      |
| <b>AC ELECTRICAL CHARACTERISTICS / CSI-2 C-PHY GLOBAL OPERATION TIMING—SEE <a href="#">Figure 14</a> (<a href="#">Note 5</a>)</b>            |                     |   |       |                              |       |         |
| Time that the Transmitter Drives the 3-Wire LP-000 Line State Immediately Before the HS <sub>x</sub> Line State Starting the HS Transmission | $t_{3-PREPARE}$     | ( <a href="#">Note 5</a> )  | 38    |                              | 95    | ns      |
| Time the Transmitter Drives LP-111 After an HS Burst.  | $t_{3-HS-EXIT}$     | ( <a href="#">Note 5</a> )  | 100   |                              |       | ns      |
| Transmitted Length of Any Low-Power State Period   | $t_{LPX}$           | ( <a href="#">Note 4</a> , <a href="#">Note 5</a> )   | 50    |                              |       | ns      |
| Initialization Time  | $t_{INIT}$          | ( <a href="#">Note 5</a> )  | 100   |                              |       | $\mu s$ |
| <b>AC ELECTRICAL CHARACTERISTICS / I<sup>2</sup>C/UART PORT TIMING—SEE <a href="#">Figure 16</a></b>   |                     |   |       |                              |       |         |
| I <sup>2</sup> C/UART Bit Rate   |                     |   | 9.6   |                              | 1000  | kbps    |
| Output Fall Time   | $t_F$               | 70% to 30%, $C_L = 20pF$ to $100pF$ , $1k\Omega$ pull-up to $V_{DDIO}$  |       | $20 \times V_{DDIO}/5$<br>5V | 150   | ns      |
| I <sup>2</sup> C/UART Wake Time  | $t_{WAKEUP}$        | From power-up, or rising edge of PWDNB to local register access. For remote register access, I <sup>2</sup> C/UART wake time is the same as lock time ( $t_{LOCK}$ ). |       | 13.0                         | 15.5  | ms      |
| <b>AC ELECTRICAL CHARACTERISTICS / I<sup>2</sup>C TIMING—SEE <a href="#">Figure 16</a></b>   |                     |   |       |                              |       |         |
| SCL Clock Frequency  | $f_{SCL}$           | Low $f_{SCL}$ range: (I2CMSTBT = 010, I2CSLVSH = 10)  | 9.6   |                              | 100   | kHz     |
|  |                     | Mid $f_{SCL}$ range: (I2CMSTBT 101, I2CSLVSH = 01)  | > 100 |                              | 400   |         |
|  |                     | High $f_{SCL}$ range: (I2CMSTBT = 111, I2CSLVSH = 00)   | > 400 |                              | 1000  |         |
|  | $t_{HD:STA}$        | $f_{SCL}$ range, Low  | 4     |                              |       | $\mu s$ |

( $V_{DD18} = 1.7V$  to  $1.9V$ ,  $V_{DD} = 0.95V$  to  $1.05V$  or  $V_{DD} = 1.14V$  to  $1.26V$ ,  $V_{DDIO} = 1.7V$  to  $3.6V$ ,  $V_{TERM} = 1.14$  to  $1.26V$ ,  $T_A = -40^\circ C$  to  $+105^\circ C$ , EP connected to PCB ground, typical values are at  $V_{DD18} = V_{DDIO} = 1.8V$ ,  $V_{DD} = 1.0V$ ,  $V_{TERM} = 1.2V$ ,  $T_A = 25^\circ C$ , unless otherwise noted. ([Note 4](#)))

| PARAMETER   | SYMBOL       | CONDITIONS                 | MIN   | TYP         | MAX  | UNITS   |
|---|--------------|----------------------------|-------|-------------|------|---------|
| Start Condition Hold Time   |              | fSCL range, Mid            | 0.6   |             |      |         |
|   |              | fSCL range, High           | 0.26  |             |      | $\mu s$ |
| Low Period of SCL Clock   | $t_{LOW}$    | fSCL range, Low            | 4.7   |             |      | $\mu s$ |
|   |              | fSCL range, Mid            | 1.3   |             |      | $\mu s$ |
|   |              | fSCL range, High           | 0.5   |             |      | $\mu s$ |
| High Period of SCL Clock  | $t_{HIGH}$   | fSCL range, Low            | 4     |             |      | $\mu s$ |
|   |              | fSCL range, Mid            | 0.6   |             |      | $\mu s$ |
|   |              | fSCL range, High           | 0.26  |             |      | $\mu s$ |
| Repeated Start Condition Setup Time   | $t_{SU:STA}$ | fSCL range, Low            | 4.7   |             |      | $\mu s$ |
|   |              | fSCL range, Mid            | 0.6   |             |      | $\mu s$ |
|   |              | fSCL range, High           | 0.26  |             |      | $\mu s$ |
| Data Hold Time  | $t_{HD:DAT}$ | fSCL range, Low            | 0     |             |      | ns      |
|   |              | fSCL range, Mid            | 0     |             |      | ns      |
|   |              | fSCL range, High           | 0     |             |      | ns      |
| Data Setup Time   | $t_{SU:DAT}$ | fSCL range, Low            | 250   |             |      | ns      |
|   |              | fSCL range, Mid            | 100   |             |      | ns      |
|   |              | fSCL range, High           | 50    |             |      | ns      |
| Setup Time for Stop Condition   | $t_{SU:STO}$ | fSCL range, Low            | 4     |             |      | $\mu s$ |
|   |              | fSCL range, Mid            | 0.6   |             |      | $\mu s$ |
|   |              | fSCL range, High           | 0.26  |             |      | $\mu s$ |
| Bus Free Time   | $t_{BUF}$    | fSCL range, Low            | 4.7   |             |      | $\mu s$ |
|   |              | fSCL range, Mid            | 1.3   |             |      | $\mu s$ |
|   |              | fSCL range, High           | 0.5   |             |      | $\mu s$ |
| Data Valid Time   | $t_{VD:DAT}$ | fSCL range, Low            |       |             | 3.45 | $\mu s$ |
|   |              | fSCL range, Mid            |       |             | 0.9  | $\mu s$ |
|   |              | fSCL range, High           |       |             | 0.45 | $\mu s$ |
| Data Valid Acknowledge Time   | $t_{VD:ACK}$ | fSCL range, Low            |       |             | 3.45 | $\mu s$ |
|   |              | fSCL range, Mid            |       |             | 0.9  | $\mu s$ |
|   |              | fSCL range, High           |       |             | 0.45 | $\mu s$ |
| Pulse Width of Spikes Suppressed  | $t_{SP}$     | fSCL range, Low            |       |             | 50   | ns      |
|   |              | fSCL range, Mid            |       |             | 50   | ns      |
|   |              | fSCL range, High           |       |             | 50   | ns      |
| Capacitive Load on Each Bus Line  | $C_B$        | ( <a href="#">Note 5</a> ) |       |             | 100  | pF      |
| <b>AC ELECTRICAL CHARACTERISTICS / SPI MAIN—SEE <a href="#">Figure 17 (Note 14)</a></b> |              |                            |       |             |      |         |
| Programmable Operating Frequency Range  | $f_{MCK}$    | ( <a href="#">Note 5</a> ) | 0.588 |             | 25   | MHz     |
| SCLK Period   | $t_{MCK}$    |                            |       | $1/f_{MCK}$ |      | ns      |

( $V_{DD18} = 1.7V$  to  $1.9V$ ,  $V_{DD} = 0.95V$  to  $1.05V$  or  $V_{DD} = 1.14V$  to  $1.26V$ ,  $V_{DDIO} = 1.7V$  to  $3.6V$ ,  $V_{TERM} = 1.14$  to  $1.26V$ ,  $T_A = -40^\circ C$  to  $+105^\circ C$ , EP connected to PCB ground, typical values are at  $V_{DD18} = V_{DDIO} = 1.8V$ ,  $V_{DD} = 1.0V$ ,  $V_{TERM} = 1.2V$ ,  $T_A = 25^\circ C$ , unless otherwise noted. ([Note 4](#)))

| PARAMETER   | SYMBOL                | CONDITIONS   | MIN             | TYP         | MAX  | UNITS    |
|---|-----------------------|--|-----------------|-------------|------|----------|
| SCLK Output Pulse-Width High/Low  | $t_{MCH}$ , $t_{MCL}$ | $C_L = 5pF$ ( <a href="#">Note 5</a> )   | $t_{MCK/2} - 3$ | $t_{MCK/2}$ |      | ns       |
| MOSI Data Output Delay  | $t_{MOD}$             | After SCLK falling edge ( <a href="#">Note 5</a> )   | -6              |             | 3    | ns       |
| MISO Input Setup Time   | $t_{MIS}$             | Before programmed sampling edge ( <a href="#">Note 5</a> )   | 13.5            |             |      | ns       |
| MISO Input Hold Time  | $t_{MIH}$             | After programmed sampling edge ( <a href="#">Note 5</a> )  | -2              |             |      | ns       |
| <b>AC ELECTRICAL CHARACTERISTICS / SPI SUBORDINATE—SEE <a href="#">Figure 18</a> (<a href="#">Note 14</a>)</b>    |                       |  |                 |             |      |          |
| Operating Frequency   | $f_{SCK}$             | ( <a href="#">Note 5</a> )   |                 |             | 25   | MHz      |
| SCLK Period   | $t_{SCK}$             |  |                 | $1/f_{SCK}$ |      | ns       |
| MISO Data Output Delay  | $t_{SOD}$             | After SCLK falling edge, ( <a href="#">Note 5</a> )  | 3               |             | 12.5 | ns       |
| MOSI Input Setup Time   | $t_{SIS}$             | Before SCLK rising edge  | 5               |             |      | ns       |
| MOSI Input Hold Time  | $t_{SIH}$             | After SCLK rising edge   | 3               |             |      | ns       |
| <b>AC ELECTRICAL CHARACTERISTICS / REFERENCE CLOCK INPUT REQUIREMENTS (CRYSTAL) (X1/OSC, X2)</b>                  |                       |  |                 |             |      |          |
| Frequency   | $f_{REF}$             |  |                 | 25          |      | MHz      |
| Frequency Stability + Frequency Tolerance   | $f_{TN}$              |  | -200            |             | +200 | ppm      |
| <b>AC ELECTRICAL CHARACTERISTICS / REFERENCE CLOCK INPUT REQUIREMENTS (EXTERNAL INPUT ON X1/OSC, X2 FLOATING)</b> |                       |  |                 |             |      |          |
| Frequency   | $f_{REF}$             |  |                 | 25          |      | MHz      |
| Frequency Stability + Frequency Tolerance   | $f_{TN}$              |  | -200            |             | +200 | ppm      |
| Duty Cycle  | DC                    |  | 40              | 50          | 60   | %        |
| Input Jitter  | $t_{JIN}$             | Forward data rate = 12Gbps bit rate, Reverse data rate = 187.5Mbps, RoR not used by serializer, Sinusoidal jitter < 1MHz (rising edge) |                 |             | 150  | ps (p-p) |
|   |                       | Forward data rate = 12Gbps bit rate, Reverse data rate = 187.5Mbps, RoR used by serializer, Sinusoidal jitter < 1MHz (rising edge)     |                 |             | 75   |          |
| Input Rise Time   | $t_R$                 | 10% to 90%   |                 | 5           |      | ns       |
| Input Fall Time   | $t_F$                 | 90% to 10%   |                 | 5           |      | ns       |

**Note 4:** Limits are 100% tested at  $T_A = +105^\circ C$ , unless otherwise noted. Limits over the operating temperature range and relevant supply voltage range are guaranteed by design and characterization. Maximum supply currents are specified for  $T_J = +105^\circ C$ .

**Note 5:** Not production tested. Guaranteed by design and characterization.

**Note 6:**  $C_{LOAD}$  includes the low-frequency equivalent transmission line capacitance. The capacitance of Tx and Rx are always assumed as < 10pF. The distributed line capacitance can be up to 50pF for a transmission line with 2ns delay.

**Note 7:** Value when driving into load impedance  $Z_{ID} = 100\Omega$ .

**Note 8:** MFP pin speed programmed to fastest setting (TTS = 00). See the [MFP Function Map and Slew Settings](#) section for details on MFP speed programming.

**Note 9:** Typical value of  $V_{CPTX}$  should be in the specified range depending upon the supply voltage used for each implementation.

**Note 10:** Measured as average across any 50mV segment of the output signal transition.

**Note 11:** The rise-time of  $t_{REOT}$  starts from the HS common-level at the moment the differential amplitude drops below 70mV, due to stopping the differential drive.

**Note 12:** Though no maximum value for  $Z_{OLP}$  is specified, the LP transmitter output impedance ensures the  $t_{RLP}/t_{FLP}$  specification is met.

**Note 13:** Differential-Mode and Common-Mode reflection coefficients are compliant with MIPI C-PHY V1.0 requirements over all specified operating frequencies.

**Note 14:** Measured at 25MHz.

### Typical Operating Characteristics

( $V_{TERM} = 1.2V$ ,  $V_{DD18} = 1.8V$ ,  $V_{DDIO} = 1.8V$ ,  $V_{DD} = 1.0V$ ,  $T_A = +25^\circ C$  unless otherwise noted. PRBS24 data. Single GMSL PHY configuration at 6Gbps or 12Gbps: SIOA or SIOB GMSL input enabled, data output 4-lane Port A or Port B. Single GMSL PHY configuration at 3Gbps: SIOA or SIOB GMSL input enabled, data output on 2-lane Port A or Port B. Dual GMSL PHY configuration: SIOA (6Gbps or 12Gbps) data output on 4-lane CSI-2 Port A, SIOB (6Gbps or 12Gbps) data output on 4-lane CSI-2 Port B. SIOA (3Gbps) data output on 2-lane CSI-2 Port A, SIOB (3Gbps) data output on 2-lane CSI-2 Port B).

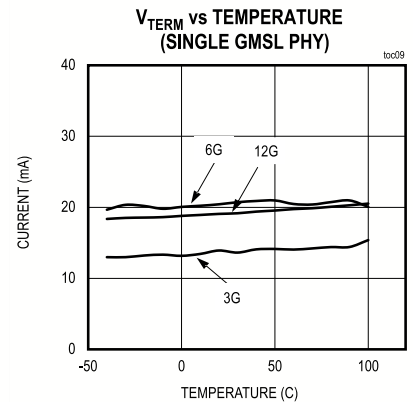
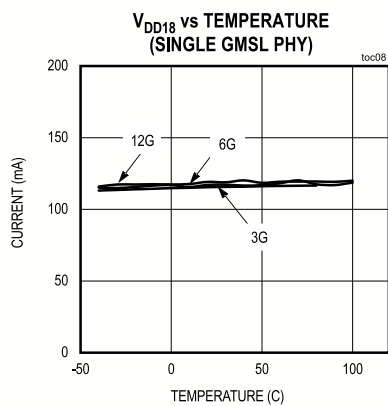
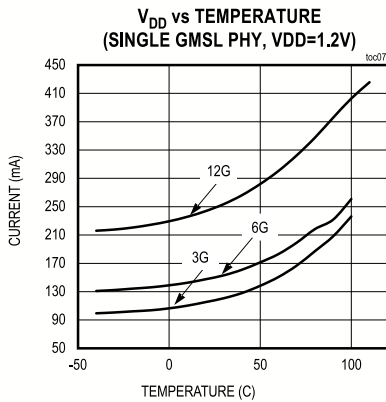
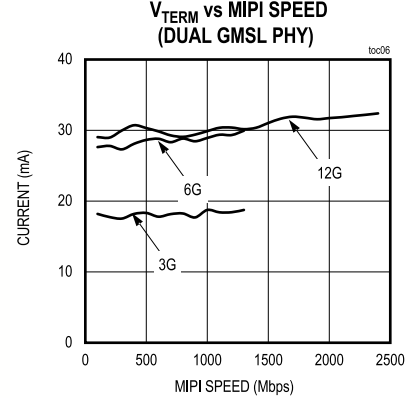
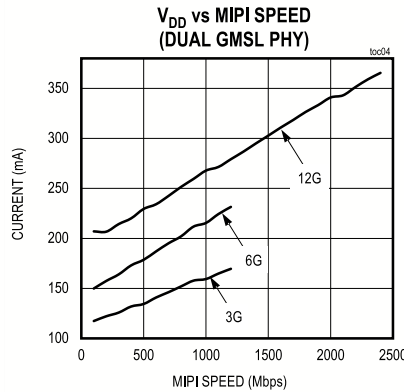
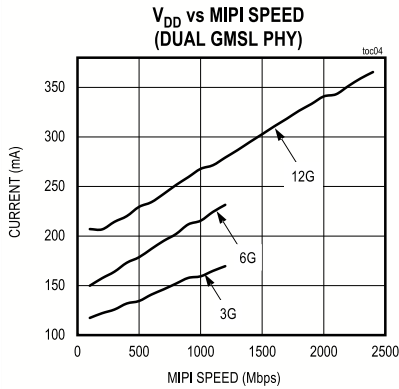
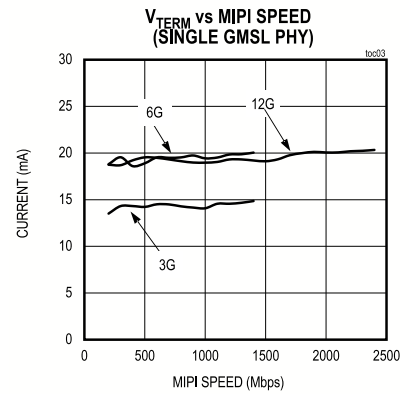
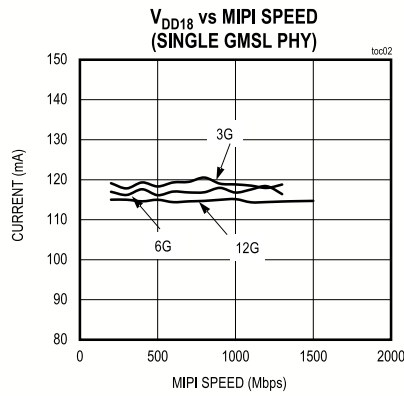
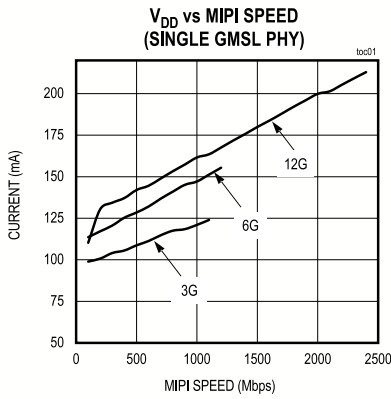

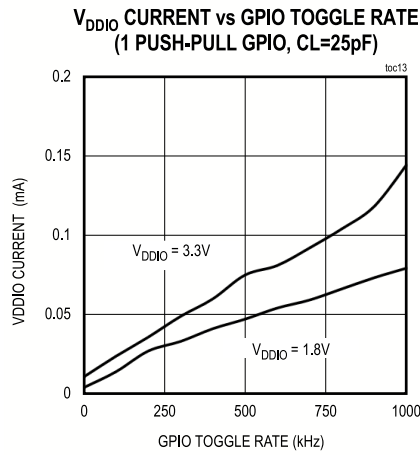
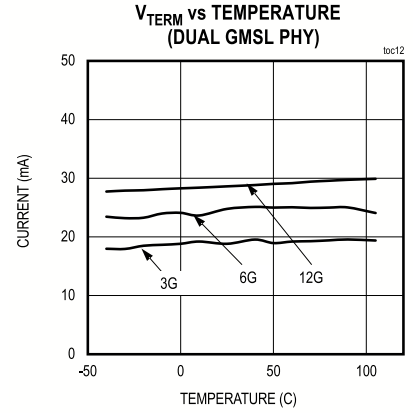
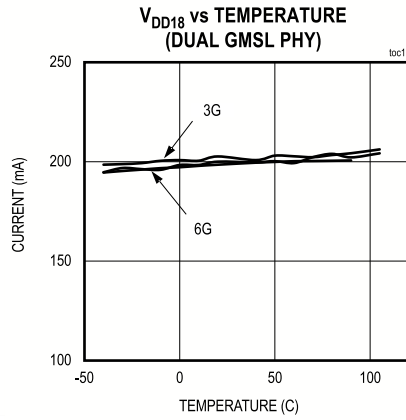
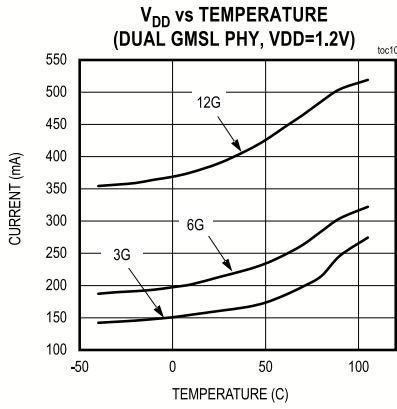

Pin Configuration

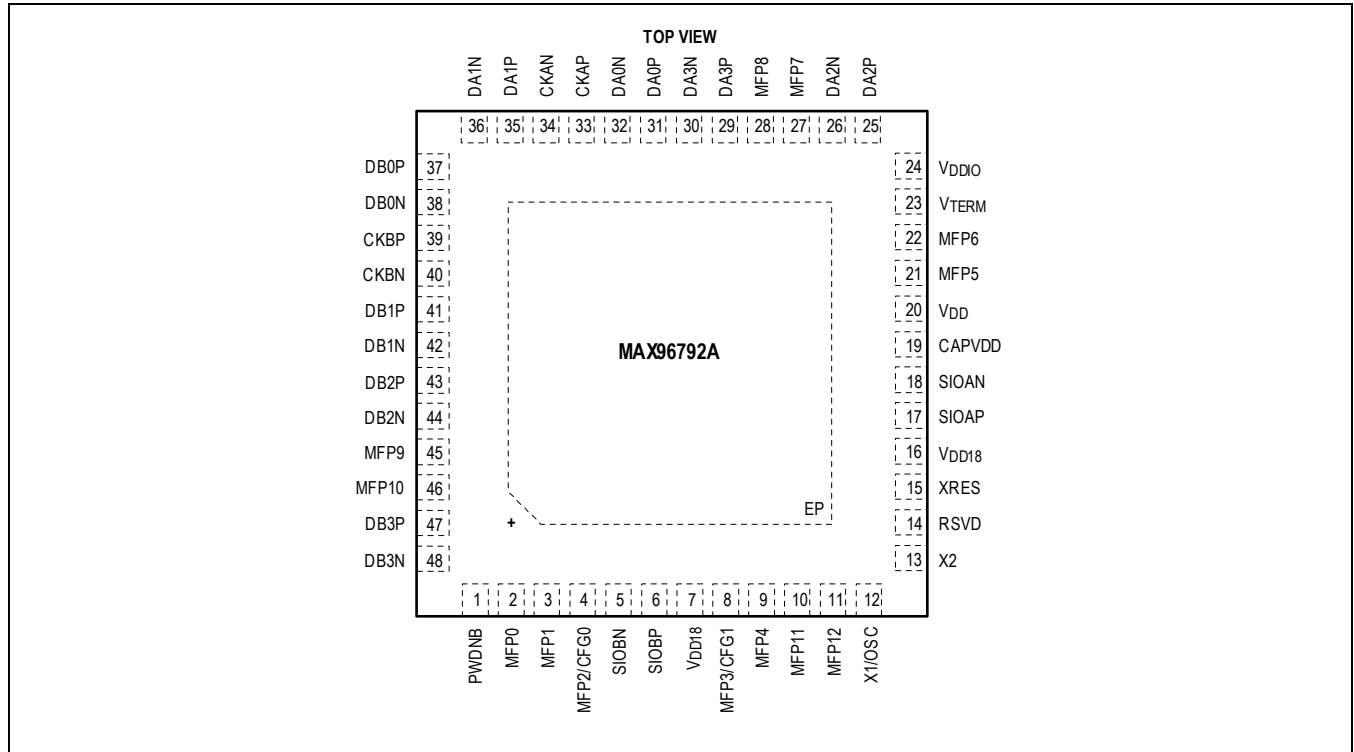

Pin Descriptions

| PIN   | NAME  | FUNCTION MODE | FUNCTION   |
|---|-------|---------------|--|
|   |       | GMSL3/2       |  |
| <b>GMSL3/2 SERIAL LINK (NOTE: LEAVE PINS OPEN IF UNUSED)</b>  |       |               |  |
| 5   | SIOBN | SIOBN         | Inverted Twisted-Pair Serial-Data Input/Output B   |
| 6   | SIOBP | SIOBP         | Noninverted Coax/Twisted Pair Serial Data Input/Output B   |
| 17  | SIOAP | SIOAP         | Noninverted Coax/Twisted-Pair Serial-Data Input/Output A   |
| 18  | SIOAN | SIOAN         | Inverted Twisted-Pair Serial-Data Input/Output A   |
| <b>CSI-2 INTERFACE (*) INDICATES DEFAULT STATE AFTER POWER-UP (NOTE: LEAVE PINS OPEN IF UNUSED)</b> |       |               |  |
| 25  | DA2P  | DA2P          | CSI-2 Port A Data Lane 2 Noninverted Output (D-PHY 4-Lane Mode).   |
| 26  | DA2N  | DA2N          | CSI-2 Port A Data Lane 2 Inverted Output (D-PHY 4-Lane Mode).  |
| 29  | DA3P  | DA3P          | CSI-2 Port A Data Lane 3 Noninverted Output (D-PHY 4-Lane Mode).   |
| 30  | DA3N  | DA3N          | CSI-2 Port A Data Lane 3 Inverted Output (D-PHY 4-Lane Mode).  |
| 31  | DA0P  | DA0P*<br>DD0A | DA0P: CSI-2 Port A Data Lane 0 Noninverted Output (D-PHY 4-Lane Mode).<br>DD0A: CSI-2 Port D Data Lane 0 A-Output (C-PHY 2-Lane Mode). |
| 32  | DA0N  | DA0N*<br>DD0B | DA0N: CSI-2 Port A Data Lane 0 Inverted Output (D-PHY 4-Lane Mode).<br>DD0B: CSI-2 Port D Data Lane 0 B-Output (C-PHY 2-Lane Mode).    |
| 33  | CKAP  | CKAP*<br>DD0C | CKAP: CSI-2 Port A Clock Lane Noninverted Output (D-PHY 4-Lane Mode).<br>DD0C: CSI-2 Port D Data Lane 0 C-Output (C-PHY 2-Lane Mode).  |
| 34  | CKAN  | CKAN*<br>DD1A | CKAN: CSI-2 Port A Clock Lane Inverted Output (D-PHY 4-Lane Mode).<br>DD1A: CSI-2 Port D Data Lane 1 A-Output (C-PHY 2-Lane Mode).     |
| 35  | DA1P  | DA1P*<br>DD1B | DA1P: CSI-2 Port A Data Lane 1 Noninverted Output (D-PHY 4-Lane Mode).<br>DD1B: CSI-2 Port D Data Lane 1 B-Output (C-PHY 2-Lane Mode). |

| PIN   | NAME      | FUNCTION MODE  | FUNCTION   |
|---|-----------|--|--|
|   |           | GMSL3/2  |  |
| 36  | DA1N      | DA1N*<br>DD1C  | DA1N: CSI-2 Port A Data Lane 1 Inverted Output (D-PHY 4-Lane Mode).<br>DD1C: CSI-2 Port D Data Lane 1 C-Output (C-PHY 2-Lane Mode).  |
| 37  | DB0P      | DB0P*<br>DE0A  | DB0P: CSI-2 Port B Data Lane 0 Noninverted Output (D-PHY 4-Lane Mode).<br>DE0A: CSI-2 Port E Data Lane 0 A-Output (C-PHY 2-Lane Mode).   |
| 38  | DB0N      | DB0N*<br>DE0B  | DB0N: CSI-2 Port B Data Lane 0 Inverted Output (D-PHY 4-Lane Mode).<br>DE0B: CSI-2 Port E Data Lane 0 B-Output (C-PHY 2-Lane Mode).  |
| 39  | CKBP      | CKBP*<br>DE0C  | CKBP: CSI-2 Port B Clock Lane Noninverted Output (D-PHY 4-Lane Mode).<br>DE0C: CSI-2 Port E Data Lane 0 C-Output (C-PHY 2-Lane Mode).  |
| 40  | CKBN      | CKBN*<br>DE1A  | CKBN: CSI-2 Port B Clock Lane Inverted Output (D-PHY 4-Lane Mode).<br>DE1A: CSI-2 Port E Data Lane 1 A-Output (C-PHY 2-Lane Mode).   |
| 41  | DB1P      | DB1P*<br>DE1B  | DB1P: CSI-2 Port B Data Lane 1 Noninverted Output (D-PHY 4-Lane Mode).<br>DE1B: CSI-2 Port E Data Lane 1 B-Output (C-PHY 2-Lane Mode).   |
| 42  | DB1N      | DB1N*<br>DE1C  | DB1N: CSI-2 Port B Data Lane 1 Inverted Output (D-PHY 4-Lane Mode).<br>DE1C: CSI-2 Port E Data Lane 1 C-Output (C-PHY 2-Lane Mode).  |
| 43  | DB2P      | DB2P   | CSI-2 Port B Data Lane 2 Noninverted Output (D-PHY 4-Lane Mode).   |
| 44  | DB2N      | DB2N   | CSI-2 Port B Data Lane 2 Inverted Output (D-PHY 4-Lane Mode).  |
| 47  | DB3P      | DB3P   | CSI-2 Port B Data Lane 3 Noninverted Output (D-PHY 4-Lane Mode).   |
| 48  | DB3N      | DB3N   | CSI-2 Port B Data Lane 3 Inverted Output (D-PHY 4-Lane Mode).  |
| <b>MULTIFUNCTION PINS (NOTE: LEAVE PINS OPEN IF UNUSED)</b> |           |  |  |
| 2   | MFP0      | GPIO0*<br>SDA1<br>RX1<br>SDA2<br>RX2<br>SCLK<br>FRSYNC_OUT<br>VS2<br>DE1/DV1<br>MS | GPIO0: Configurable General-Purpose Input or Output. Power-up default is GPIO general-purpose input with a 1MΩ pull-down to ground.<br>SDA1: Pass-Through I <sup>2</sup> C Data Input/Open-Drain Output with an Internal 40kΩ Pull-Up to V <sub>DDIO</sub> .<br>RX1: Pass-Through UART Input with an Internal 40kΩ Pull-Up to V <sub>DDIO</sub> .<br>SDA2: Pass-Through I <sup>2</sup> C Data Input/Open-Drain Output with an Internal 40kΩ Pull-Up to V <sub>DDIO</sub> .<br>RX2: Pass-Through UART Input with an Internal 40kΩ Pull-Up to V <sub>DDIO</sub> .<br>SCLK: SPI Clock. When configured as a main, push-pull clock output. When configured as a subordinate, clock input with internal 1MΩ pull-down to ground.<br>FRSYNC_OUT: Frame Sync Push-Pull Output.<br>VS2: Video Stream Vertical Sync Monitor Push-Pull Output.<br>DE1/DV1: Video Stream Data Enable or Data Valid Monitor Push-Pull Output.<br>MS: UART Mode Select with Internal 1MΩ Pull-Down to Ground. MS state can also be temporarily overwritten by a register write. |
| 3   | MFP1      | LOCK*<br>SCL1<br>TX1<br>SCL2<br>TX2<br>GPIO1                                       | LOCK: Open-Drain Lock Indication Output with an Internal 40kΩ Pull-Up to V <sub>DDIO</sub> .<br>SCL1: Pass-Through I <sup>2</sup> C Clock Input/Open-Drain Output with an Internal 40kΩ Pull-Up to V <sub>DDIO</sub> .<br>TX1: Pass-Through UART Open-Drain Output with an Internal 40kΩ Pull-Up to V <sub>DDIO</sub> .<br>SCL2: Pass-Through I <sup>2</sup> C Clock Input/Open-Drain Output with an Internal 40kΩ Pull-Up to V <sub>DDIO</sub> .<br>TX2: Pass-Through UART Open-Drain Output with an Internal 40kΩ Pull-Up to V <sub>DDIO</sub> .<br>GPIO1: General-Purpose Input or Output.  |
| 4   | MFP2/CFG0 | GPO2*<br>SS1<br>BNE<br>CFG0  | CFG0: Configuration Pin. Voltage at pin sets device mode, which is latched at power-up. Connect to a resistor divider between V <sub>DDIO</sub> and EP. See <a href="#">Table 12</a> .<br>GPO2*: General-purpose output. Power-up default is high impedance.<br>SS1: SPI Subordinate Select. When configured as the main, Subordinate 1 Select push-pull output.<br>BNE: When Configured as SPI Subordinate, SPI Buffer Not Empty Push-Pull Output. When BNE is high, SPI data is available.   |
| 8   | MFP3/CFG1 | GPO3*<br>CFG1<br>VS1   | GPO3: General-Purpose Push-Pull Output. Power-up default is high impedance.  |

| PIN | NAME  | FUNCTION MODE   | FUNCTION  |
|-----|-------|---|---|
|     |       | GMSL3/2   |   |
|     |       | DE0/DV0<br>SS2  | CFG1: Configuration Pin. Voltage at pin sets device mode, which is latched at power-up. Connect to a resistor divider between V <sub>DDIO</sub> and EP. See <a href="#">Table 13</a> . VS1: Video Stream Vertical Sync Monitor Push-Pull Output.<br>DE0/DV0: Video Stream Data Enable or Data Valid Monitor Push-Pull Output.<br>SS2: SPI Subordinate Select. When configured as the main, Subordinate 2 Select push-pull output.   |
| 9   | MFP4  | ERRB*<br>GPIO4<br>RO(Alt)                                 | ERRB: Open-Drain Error Indication Output with an Internal 40kΩ Pull-Up to V <sub>DDIO</sub> . When ERRB is low, a data error, line fault, or interrupt is detected. ERRB is high when PWDNB is low.<br>GPIO4: General-Purpose Input or Output.<br>RO(Alt): When Configured as a Subordinate, SPI Mode-Select Input with an Internal 1MΩ Pull-Down to Ground. When RO is high, enables a main read from MISO. When RO is low, enables a main write to MOSI.  |
| 21  | MFP5  | RX1*<br>RX2<br>SDA1<br>GPIO5<br>SDA2<br>MOSI<br>LOCK(Alt) | RX1: Pass-Through UART Input with an Internal 40kΩ Pull-Up to V <sub>DDIO</sub> (Default 1Mbps Rate).<br>RX2: Pass-Through UART Input with an Internal 40kΩ Pull-Up to V <sub>DDIO</sub> .<br>SDA1: Pass-Through I <sup>2</sup> C Data Input/Open-Drain Output with an Internal 40kΩ Pull-Up to V <sub>DDIO</sub> .<br>GPIO5: Configurable General-Purpose Input or Output. Power-up default with a receiver enabled and open-drain driver high with an internal 40kΩ pull-up to V <sub>DDIO</sub> .<br>SDA2: Pass-Through I <sup>2</sup> C Data Input/Open-Drain Output with an Internal 40kΩ Pull-Up to V <sub>DDIO</sub> .<br>MOSI: SPI Main Out Subordinate In. When configured as main, the push-pull output drives data to the external subordinate. When configured as a subordinate, input with an internal 1MΩ pull-down to ground that receives data from external main.<br>LOCK(Alt): Alternate Lock Indicator. Open-drain lock indication output with an internal 40kΩ pull-up to V <sub>DDIO</sub> . |
| 22  | MFP6  | TX1*<br>TX2<br>SCL2<br>SCL1<br>GPIO6<br>MISO              | TX1: Pass-Through UART Output with an Internal 40kΩ Pull-Up to V <sub>DDIO</sub> (Default 1Mbps Rate).<br>TX2: Pass-Through UART Output with an Internal 40kΩ Pull-Up to V <sub>DDIO</sub> .<br>SCL2: Pass-Through I <sup>2</sup> C Clock Input/Open-Drain Output with an Internal Pull-Up to V <sub>DDIO</sub> .<br>SCL1: Pass-Through I <sup>2</sup> C Clock Input/Open-Drain Output with an Internal Pull-Up to V <sub>DDIO</sub> .<br>GPIO6: Configurable General-Purpose Input or Output. Power-up default with a receiver enabled and open-drain driver high with an internal 40kΩ pull-up to V <sub>DDIO</sub> .<br>MISO: SPI Main In Subordinate Out. When configured as a main, input with an internal 1MΩ pull-down to ground that receives data from the external subordinate. When configured as a subordinate, push-pull output that drives data to an external main.  |
| 27  | MFP7  | GPI7*<br>LMN0<br>RO                                       | GPI7: General-Purpose Input with a 1MΩ Pull-Down to Ground.<br>LMN0: Line Fault Monitor Input.<br>RO: When Configured as a Subordinate, SPI Mode-Select Input with an Internal 1MΩ Pull-Down to Ground. When RO is high, enables a main read from MISO. When RO is low, enables a main write to MOSI.   |
| 28  | MFP8  | GPI8*<br>LMN1   | GPI8: General-Purpose Input with a 1MΩ Pull-Down to Ground.<br>LMN1: Line Fault Monitor Input.  |
| 45  | MFP9  | GPI9*<br>LMN2   | GPI9: General-Purpose Input with a 1MΩ Pull-Down to Ground.<br>LMN2: Line Fault Monitor Input.  |
| 46  | MFP10 | GPI10*<br>LMN3  | GPI10: General-Purpose Input with a 1MΩ Pull-Down to Ground.<br>LMN3: Line Fault Monitor Input.   |
| 10  | MFP11 | SDA<br>RX*  | RX: UART Input with Internal 40kΩ Pull-Up to V <sub>DDIO</sub> (SDA or RX Selected by CFG0 at Power-Up).  |

| PIN   | NAME              | FUNCTION MODE             | FUNCTION  |
|---|-------------------|---------------------------|---|
|   |                   | GMSL3/2                   |   |
|   |                   | GPI11_ODO11               | SDA: I <sup>2</sup> C Data Input/Open-Drain Output with an Internal 40kΩ Pull-Up to V <sub>DDIO</sub> (SDA or RX Selected by CFG0 at Power-Up).<br>GPI11_ODO11: General-Purpose Input and/or Open-Drain Output with an Internal 40kΩ Pull-Up to V <sub>DDIO</sub> .   |
| 11  | MFP12             | SCL<br>TX*<br>GPI12_ODO12 | TX: UART Open-Drain Output with an Internal 40kΩ Pull-Up to V <sub>DDIO</sub> (SCL or TX Selected by CFG0 at Power-Up).<br>SCL: I <sup>2</sup> C Clock Input/Open-Drain Output with an Internal 40kΩ Pull-Up to V <sub>DDIO</sub> (SCL or TX Selected by CFG0 at Power-Up).<br>GPI12_ODO12: General-Purpose Input and/or Open-Drain Output with an Internal 40kΩ Pull-Up to V <sub>DDIO</sub> . |
| <b>MISCELLANEOUS – SEE <a href="#">Table 3</a></b>  |                   |                           |   |
| 1   | PWDNB             | PWDNB                     | PWDNB: Active-Low, Power-Down Input with an Internal 1MΩ Pull-Down to Ground. Set PWDNB Low to Enter Power-Down Mode.   |
| 12  | X1/OSC            | X1/OSC                    | Crystal/Oscillator Input. If a crystal is used, connect to one terminal of a 25MHz ±200ppm crystal and connect a load capacitor from X1/OSC to EP (load capacitor value depends on crystal used). If an oscillator is used, supply a 25MHz ±200ppm signal.  |
| 13  | X2                | X2                        | Crystal Input. Connect to one terminal of a 25MHz ±200ppm crystal and connect a load capacitor from X1/OSC to EP (load capacitor value depends on crystal used). Leave open if an oscillator is used.   |
| 15  | XRES              | XRES                      | Used to Calibrate SIO Output Driver Swings. Connect a 402Ω ±1% resistor between XRES and EP.  |
| 19  | CAP_VDD           | CAP_VDD                   | Decoupling Capacitor for 1V Core Supply.  |
| 14  | RSVD              | RSVD                      | Reserved. Do not connect.   |
| <b>POWER SUPPLIES – SEE <a href="#">Table 3</a></b> |                   |                           |   |
| 16  | V <sub>DD18</sub> | V <sub>DD18</sub>         | 1.8V Analog Supply.   |
| 7   | V <sub>DD18</sub> | V <sub>DD18</sub>         | 1.8V Analog Supply.   |
| 20  | V <sub>DD</sub>   | V <sub>DD</sub>           | 1.0V Core Supply. This pin includes an optional on-chip LDO. Connect a 0.95V to 1.05V supply to bypass LDO. Connect a 1.14V to 1.26V supply to use the internal 1.0V regulator. To use the internal 1V regulator, first write REG_ENABLE = 1, and then write REG_MNL = 1. Place decoupling capacitor connected to PCB ground plane as close to pin as possible.                                 |
| 24  | V <sub>DDIO</sub> | V <sub>DDIO</sub>         | 1.8V to 3.3V I/O supply.  |
| 23  | V <sub>TERM</sub> | V <sub>TERM</sub>         | 1.14V to 1.26V MIPI supply. Bypass V <sub>TERM</sub> to EP with a 0.1μF capacitor placed as close as possible to the device.  |
| EP  | EP                | EP                        | Exposed Pad. EP is internally connected to device ground. EP MUST be connected to the PCB ground plane through an array of vias for proper thermal and electrical performance.  |

**Functional Block Diagram**  
**Block Diagram**

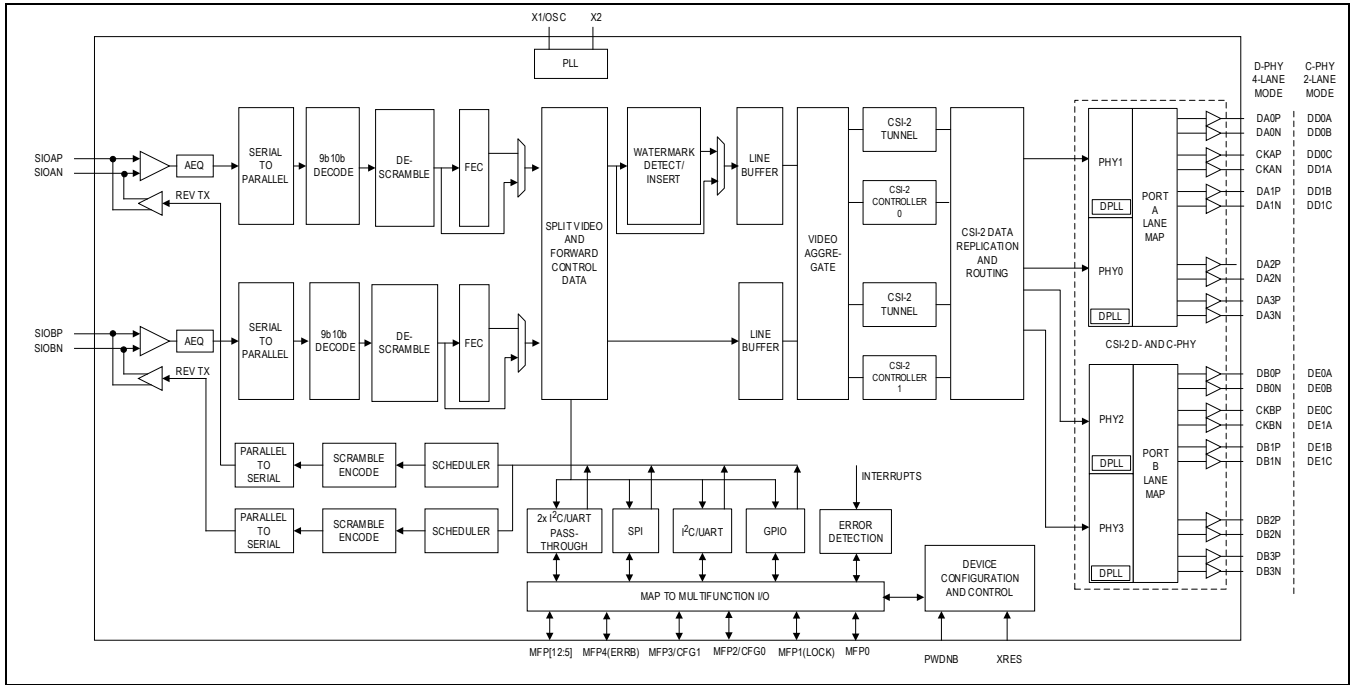

## Configuration Pin Connections

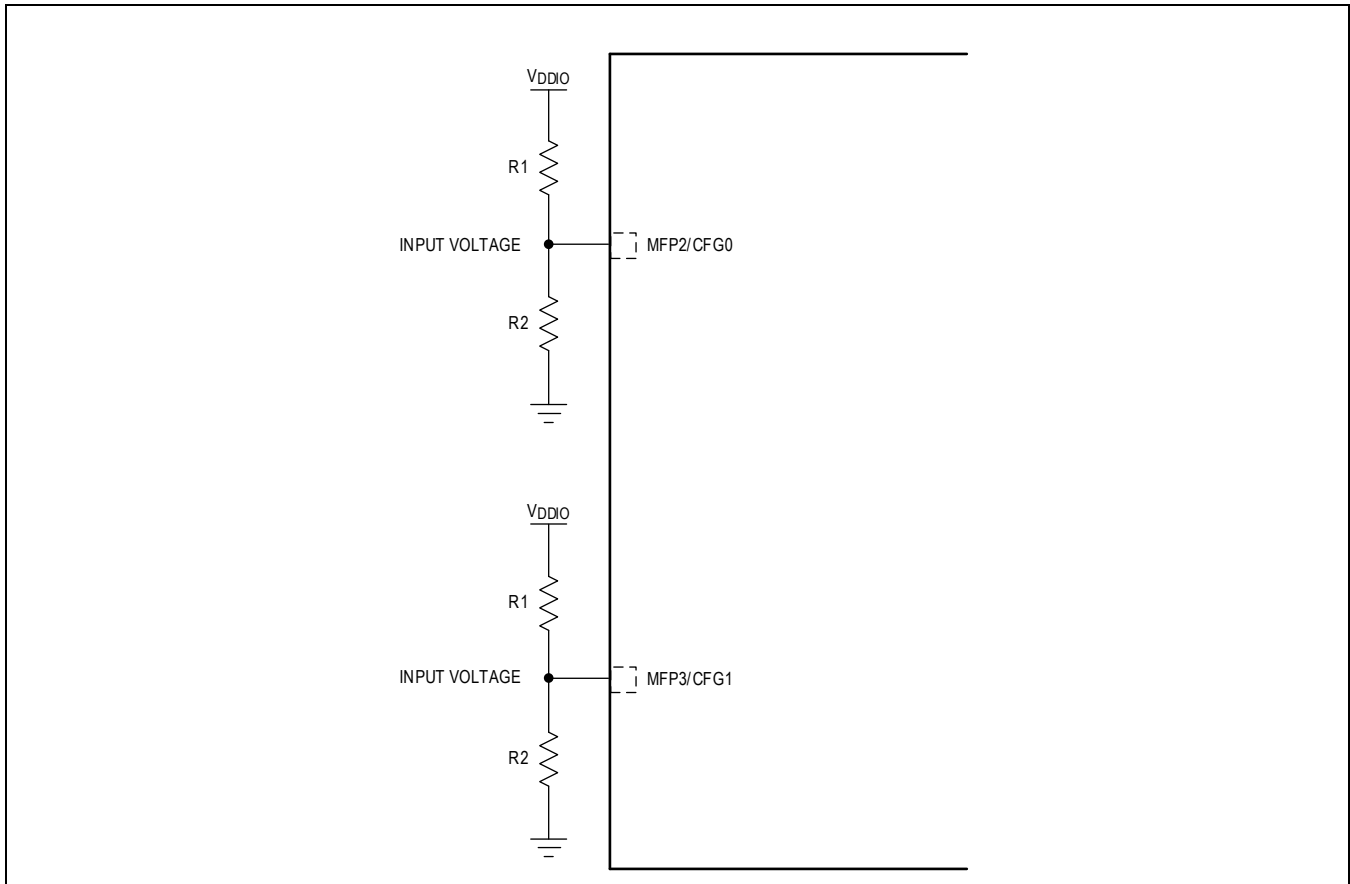

Figure 1. Configuration Pin Connection

## Detailed Description

### Additional Documentation

This data sheet contains electrical specifications, pin and functional descriptions, feature overviews, and register definitions. The following information is needed to correctly design with this device:

- The **GMSL3 Channel Specification** and **GMSL2 Channel Specification** contain physical layer requirements for the PCB traces, cables, and connectors for GMSL3 12Gbps PAM4 links and GMSL2 3Gbps or 6Gbps NRZ links, respectively.
- The **GMSL3 Hardware Design** and **GMSL2 Hardware Design Guide** contain recommendations for PCB design, applications circuits, selection of external components, and guidelines for use of GMSL3 and GMSL2 signal integrity tools.
- The **GMSL3 User Guide** and **GMSL2 User Guide** contain detailed programming guidelines for device features.
- **Errata sheets** contain deviations from published device specifications, and are specific to part number and revision ID.

Contact the factory for these documents and additional guidance on MAX96792A features.

## Recommended Operating Conditions

**Table 2. Recommended Operating Conditions**

| PARAMETER                                      | PIN NAME          | NOMINAL VOLTAGE | MIN  | TYP | MAX  | UNIT              |
|--|-------------------|-----------------|------|-----|------|-------------------|
| Supply Voltage Range                           | V <sub>TERM</sub> |                 | 1.14 | 1.2 | 1.26 | V                 |
|  | V <sub>DD18</sub> |                 | 1.7  | 1.8 | 1.9  |                   |
|  | V <sub>DD</sub>   | 1.0V            | 0.95 | 1.0 | 1.05 |                   |
|  |                   | 1.2V            | 1.14 | 1.2 | 1.26 |                   |
|  | V <sub>DDIO</sub> | 1.8V            | 1.7  | 1.8 | 1.9  |                   |
| 3.3V   |                   | 3.0             | 3.3  | 3.6 |      |                   |
| Maximum Supply Noise*                          | V <sub>TERM</sub> |                 |      | 50  |      | mV <sub>P-P</sub> |
|  | V <sub>DD18</sub> |                 |      | 25  |      |                   |
|  | V <sub>DD</sub>   | 1.0V            |      | 50  |      |                   |
|  |                   | 1.2V            |      | 50  |      |                   |
|  | V <sub>DDIO</sub> | 1.8V            |      | 50  |      |                   |
| 3.3V   |                   |                 | 100  |     |      |                   |
| Operating Junction Temperature, T <sub>J</sub> |                   |                 | -40  |     | +125 | °C                |

\* Supply noise < 1MHz. Assume supply voltage ripple to be symmetric around the measured DC supply voltage. For example, 25mV<sub>P-P</sub> means ±12.5mV peak voltage.

## External Component Requirements

**Table 3. External Component Requirements**

| COMPONENT                                | SYMBOL            | CONDITION   | VALUE                             | UNIT |
|--|-------------------|---|-----------------------------------|------|
| XRES                                     | R <sub>XRES</sub> | Connect R <sub>XRES</sub> resistor between XRES pin and ground.   | 402 ±1%.<br>Use a single resistor | Ω    |
| Line-Fault Pull-Down Resistor            | R <sub>PD</sub>   | Connect to ground at far end of Coax/STP cable; only required if line-fault detection is used.  | 49.9 ±1%                          | kΩ   |
| Line-Fault Series Resistor - Coax Mode   | R <sub>EXT1</sub> | LMN0, LMN1, LMN2, or LMN3   | 48.7 ±1%                          | kΩ   |
|  | R <sub>EXT2</sub> |   | DNI                               |      |
| Line-Fault Series Resistor - STP Mode    | R <sub>EXT1</sub> | See the Line-Fault section in <a href="#">Detailed Description</a> for STP mode.  | 48.7 ±1%                          | kΩ   |
|  | R <sub>EXT2</sub> | See the Line-Fault section in <a href="#">Detailed Description</a> for STP mode.  | 42.2 ±1%                          |      |
| Link Isolation Capacitors                | C <sub>LINK</sub> | Place close to the SIO_ pins (5, 6, 17, 18) used in the application.  | 0.1                               | μF   |
| Coax Mode Termination Resistor           | R <sub>TERM</sub> | In Coax mode, connect R <sub>TERM</sub> between unused SIO pin and ground on each coax link.  | 49.9 ±1%                          | Ω    |
| Crystal                                  |                   | Place as close as possible to pins 12 and 13.   | 25MHz ±200ppm                     |      |
| Crystal Load Capacitors                  |                   | Use crystal loading capacitor guidance from the crystal manufacturer. Select values that compensate for the X1 and X2 input, and PCB node capacitances. Place the capacitors as close as possible to pin 12 (X1/OSC) and pin 13 (X2). |                                   |      |
| V <sub>DDIO</sub> Decoupling Capacitor*  |                   | Place a 0.01μF capacitor as close as possible to pin 24. Include a minimum of 10μF bulk decoupling on the PCB.  | 0.01 + 10                         | μF   |
| V <sub>DD18</sub> Decoupling Capacitors* |                   | Place a 0.01μF capacitor as close as possible to pins 7 and 16. Connect both V <sub>DD18</sub> pins together and include a minimum of 10μF bulk decoupling on the PCB.  | (2x) 0.01 + 10                    | μF   |
| V <sub>TERM</sub> Decoupling Capacitor*  |                   | Place a 0.01μF capacitor as close as possible to pin 23. Include a minimum of 10μF bulk decoupling on the PCB.  | 0.01 + 10                         | μF   |

|  |        |   |                              |    |
|--|--------|---|------------------------------|----|
| V <sub>DD</sub> Decoupling Capacitor*            |        | Place a 0.1μF capacitor as close as possible to pin 20. Include a minimum of 10μF bulk decoupling on the PCB.   | 0.1 + 10                     | μF |
| CAP_VDD Decoupling Capacitor                     |        | Place a 0.1μF capacitor as close as possible to pin 19. Include a minimum of 10μF bulk decoupling near the pin. | 0.1 + 10                     | μF |
| Open-Drain Pull-Up Resistors                     |        | Application-specific. Quantity and values depend on multifunction GPIO pin configurations.                      |                              |    |
| Resistors for Configuration Pin Resistor-Divider | R1, R2 | Place resistor-divider close to pin 4 (MFP2/CFG0).  | See <a href="#">Table 12</a> | Ω  |
|  | R1, R2 | Place resistor-divider close to pin 8 (MFP3/CFG1).  | See <a href="#">Table 13</a> | Ω  |

\* With exception of CAP\_VDD, power supply decoupling capacitor values are recommendations only. The board designer determines the necessary decoupling for the specific application.

## ESD Protection

**Table 4. ESD Protection**

| PARAMETER      | SYMBOL           | CONDITIONS   | MIN | TYP | MAX | UNIT |
|----------------|------------------|--|-----|-----|-----|------|
| SIO__          | V <sub>ESD</sub> | Human Body Model (HBM), R <sub>D</sub> = 1.5kΩ, C <sub>S</sub> = 100pF     |     | ±8  |     | kV   |
|                |                  | ISO10605, R <sub>D</sub> = 330Ω, C <sub>S</sub> = 150pF, Contact Discharge |     | ±6  |     |      |
|                |                  | ISO10605, R <sub>D</sub> = 330Ω, C <sub>S</sub> = 150pF, Air Discharge     |     | ±6  |     |      |
|                |                  | AEC-Q100-011 Rev-C1, Charged Device Model (CDM)                            |     | 750 |     | V    |
| All Other Pins | V <sub>ESD</sub> | Human Body Model (HBM), R <sub>D</sub> = 1.5kΩ, C <sub>S</sub> = 100pF     |     | ±4  |     | kV   |
|                |                  | AEC-Q100-011 Rev-C1, Charged Device Model (CDM)                            |     | 750 |     | V    |

Functional Diagrams

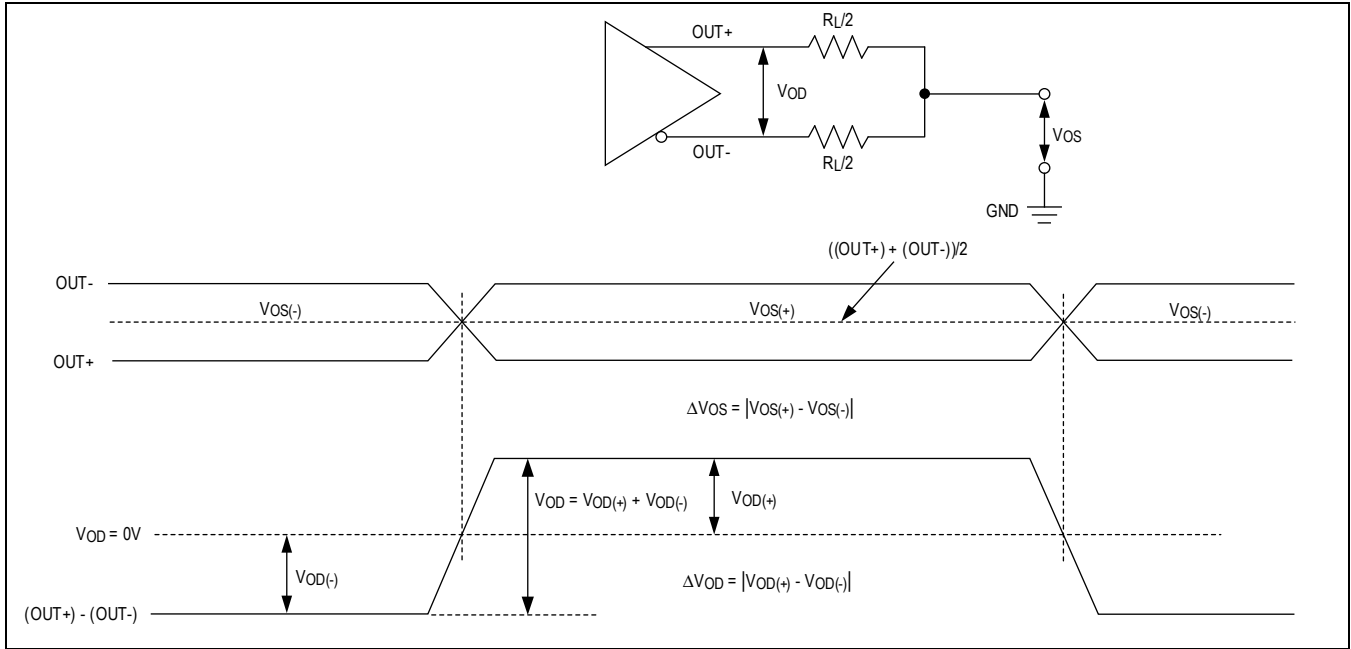

Figure 2. GMSL3 Reverse-Channel Serial Outputs

**Contact factory for  
“Ideal Single-Ended and Resulting Differential High-Speed Signals”  
figure.**

Figure 3. Ideal Single-Ended and Resulting Differential High-Speed Signals

**Contact factory for  
“Possible  $\Delta V_{CMTX}$  and  $\Delta V_{OD}$  Distortions of Single-Ended HS Signals”  
figure.**

Figure 4. Possible  $\Delta V_{CMTX}$  and  $\Delta V_{OD}$  Distortions of Single-Ended HS Signals

**Contact factory for  
“D-PHY LP Signaling Levels”  
figure.**

*Figure 5. D-PHY Signaling Levels*

**Contact factory for  
“C-PHY DC Characteristics”  
figure.**

*Figure 6. C-PHY DC Characteristics*

**Contact factory for  
“C-PHY Possible  $\Delta V_{CPTX}$  and  $\Delta V_{OD}$  Distortions of  
Single-Ended HS Signals”  
figure.**

*Figure 7. C-PHY Possible  $\Delta V_{CPTX}$  and  $\Delta V_{OD}$  Distortions of Single-Ended HS Signals*

**Contact factory for  
“C-PHY Ideal Single-Ended and Resulting Differential High-Speed Signals”  
figure.**

*Figure 8. C-PHY Ideal Single-Ended and Resulting Differential High-Speed Signals*

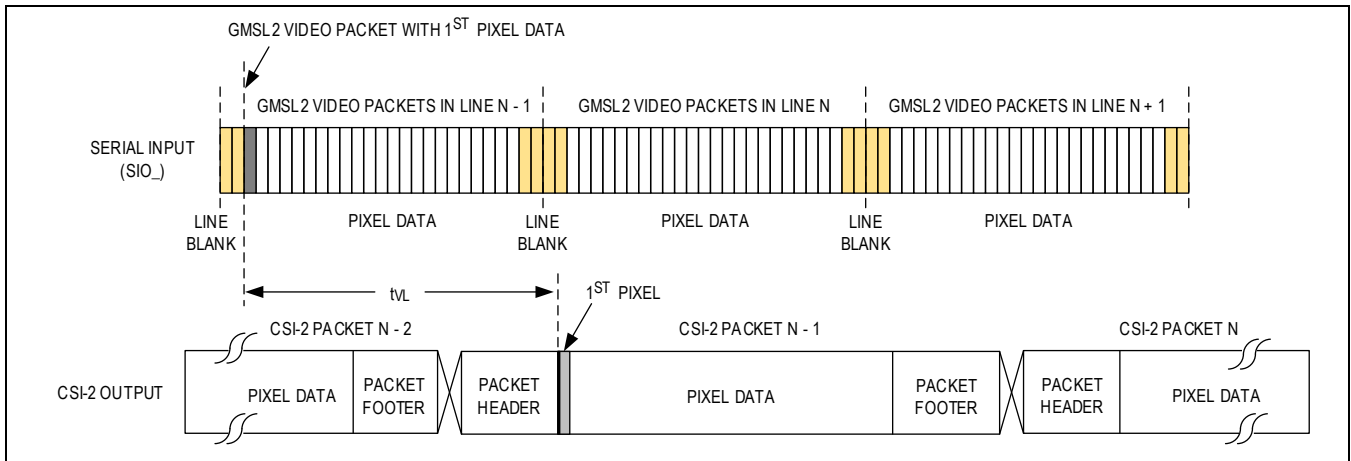

Figure 9. GMSL3 Video Latency

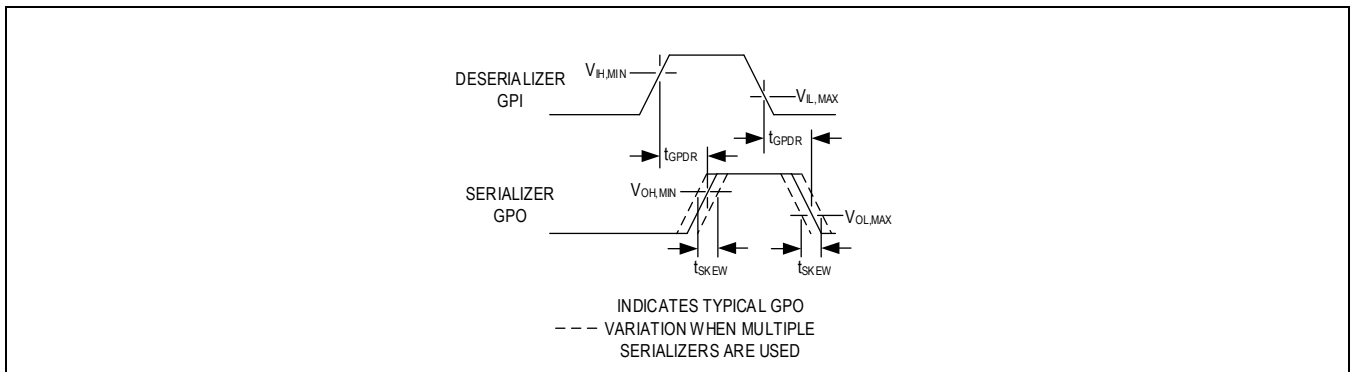

Figure 10. GPI-to-GPO Delay and Skew

**Contact factory for  
“D-PHY High-Speed Data Transmission in Bursts”  
figure.**

Figure 11. D-PHY High-Speed Data Transmission in Bursts

**Contact factory for  
“D-PHY Data Clock Timing” figure.**

Figure 12. D-PHY Data Clock Timing

**Contact factory for  
“Switching the Clock Lane between Clock Transmission  
and Low-Power Mode” figure.**

Figure 13. Switching the Clock Lane between Clock Transmission and Low-Power Mode

**Contact factory for  
“D-PHY High-Speed Skew Calibration”  
figure.**

Figure 14. D-PHY High-Speed Skew Calibration

**Contact factory for  
“C-PHY High-Speed Data Transmission in Bursts”  
figure.**

Figure 15. C-PHY High-Speed Data Transmission in Bursts

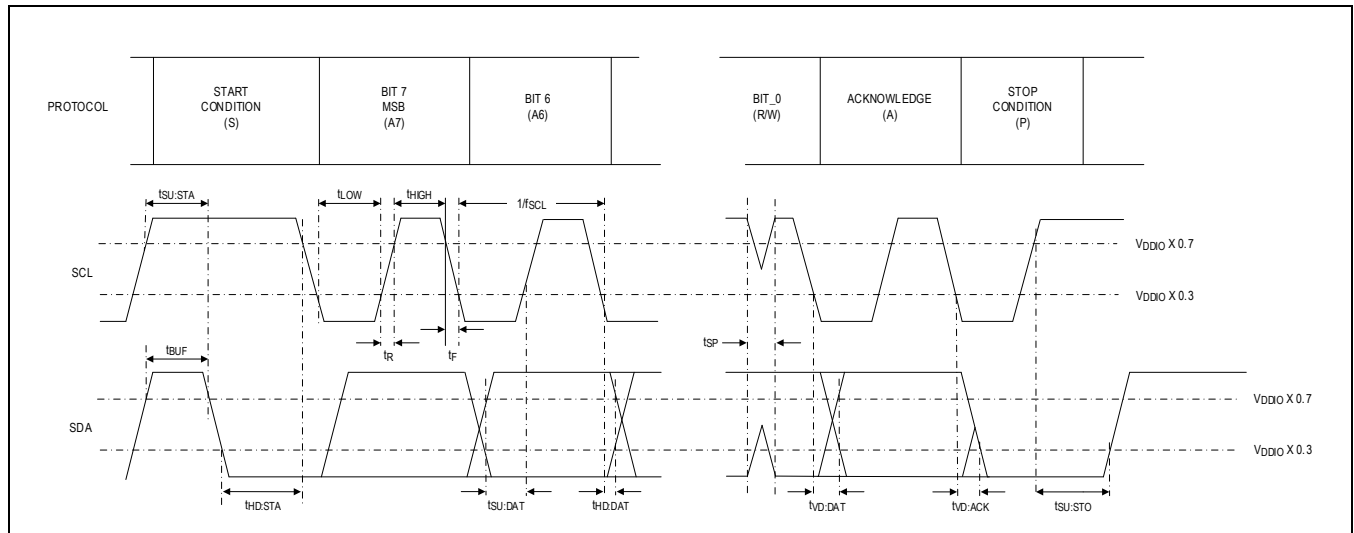

Figure 16. I<sup>2</sup>C Timing Parameters

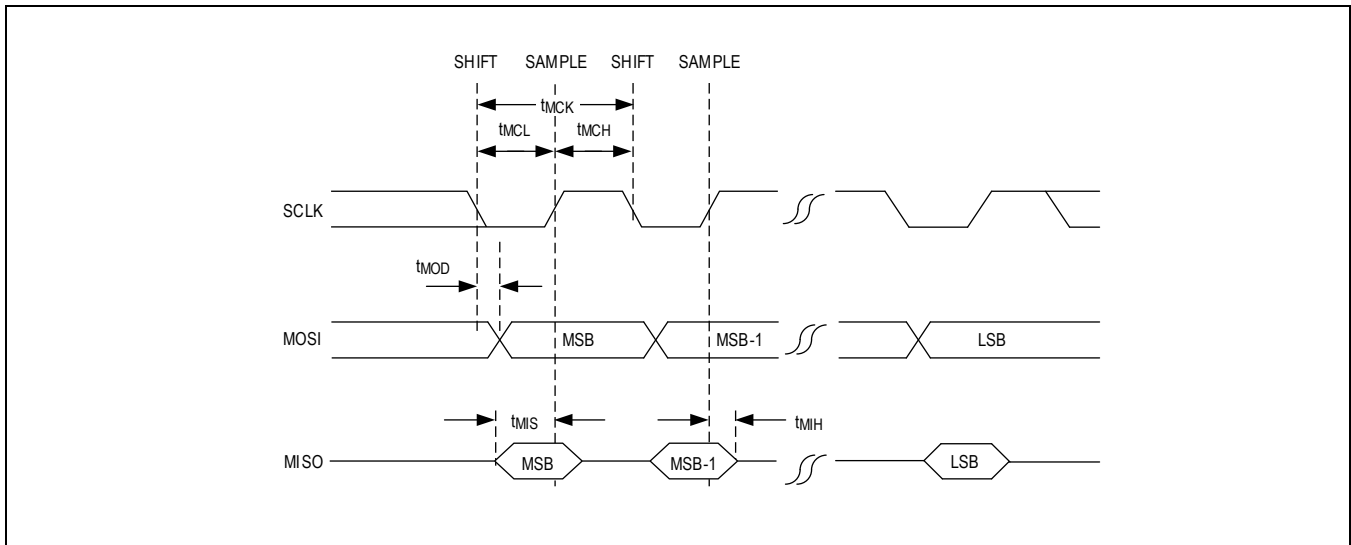

Figure 17. SPI Main-Mode Timing Parameters

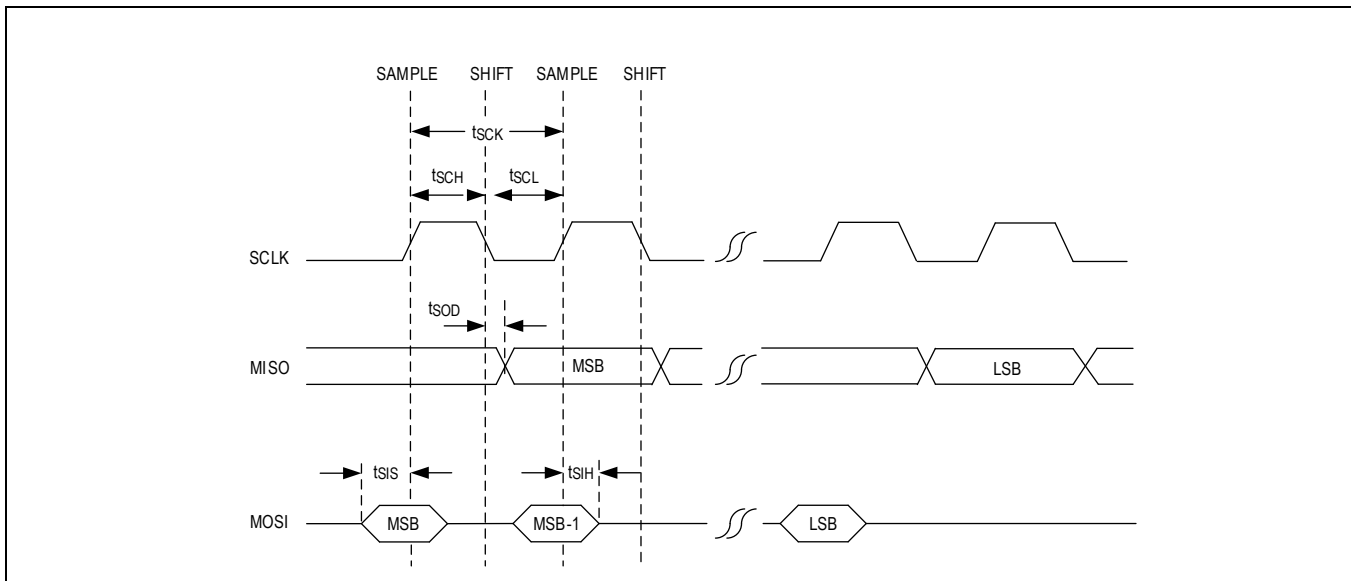

Figure 18. SPI Subordinate-Mode Timing Parameters

### Introduction

Analog Devices' GMSL3 serializers and deserializers provide high-speed, low bit-error-rate, bidirectional serial data transport. They support a comprehensive suite of sensor and communication interfaces over a single wire. The MAX96792A deserializer supports two modes of operation to transmit MIPI CSI-2 data over the line. Pixel mode offers flexible video data transfer, while Tunneling mode provides bandwidth-efficient CSI-2 video data transfer with inherent end-to-end data integrity.

GMSL3 deserializers support up to 12Gbps forward and 187.5Mbps reverse packetized-data transmission over each fixed-speed link. The MAX96792A's inputs can be aggregated such that incoming data from two remotely located sensors is combined and routed to any available combination of CSI-2 outputs. Once aggregated, the data can also be replicated to drive two SoCs.

The following sections provide a brief overview of the device functions and features. Contact the factory for additional information, and details on configuration of each function and feature.

## Product Overview

The MAX96792A GMSL3/2 dual-channel deserializer converts data on single or dual GMSL serial inputs to CSI-2 packets on one or two CSI-2 output ports. It also sends and receives side-channel data, enabling full-duplex transmission of forward-path sensor data and bidirectional data over low-cost 50Ω coax or 100Ω STP cables that meet the GMSL3 channel specifications.

The MAX96792A's CSI-2 output interfaces are configurable as C-PHY or D-PHY. The interfaces can be configured as dual four-lane D-PHY v1.2 or a dual two-lane C-PHY v1.0 output ports. The number of active D-PHY v1.2 data lanes is programmable as one, two, three, or four lanes. The C-PHY interface is programmable as one or two lanes. It supports data types including RAW8/10/12/14/16/20, RGB555/666/888/YUV422 8/10-bit, user-defined, and generic long-packet data types. It also supports up to 16 virtual channels.

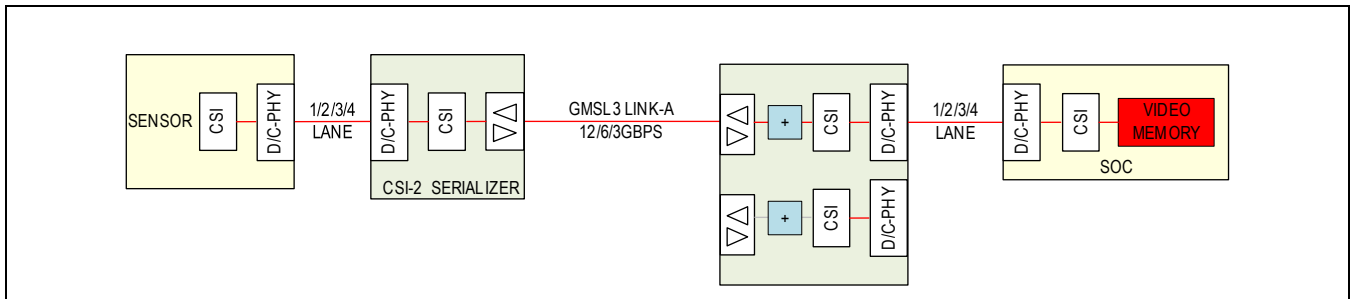

Figure 19. Single Link

A basic use-case is a single sensor having a MIPI D-PHY output, as shown in [Figure 19](#) with the sensor's output sent to an SoC at a data rate of 3Gbps, 6Gbps, or 12Gbps. Two GMSL2 or GMSL3 serializers can be used with one MAX96792A deserializer to connect two sensors to one or two SoCs. The cable types, sensor timing, and data rates do not have to be the same, the links can be set to either forward rate (both 6Gbps or 12Gbps). See [Figure 20](#). Data from Link A and Link B are output on separate, dedicated CSI-2 ports for capture by the SoC. Dedicated ports allow an SoC with slower D-PHY lanes to capture data from two sources.

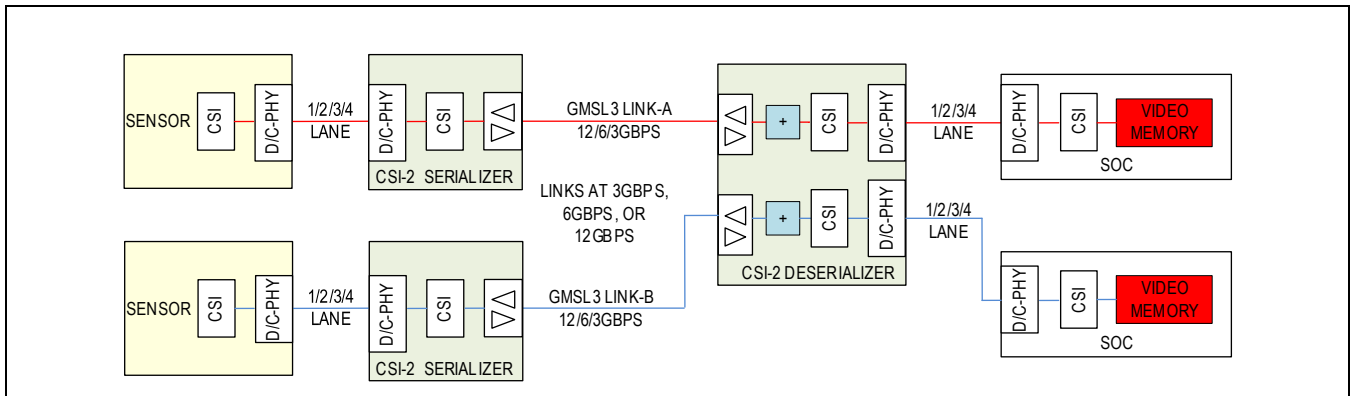

Figure 20. Dual Link, Separate Data

The MAX96792A supports data aggregation, as detailed in [Figure 21](#). The sources can have different video timing and resolution, the serial links can be set to either forward rate (3Gbps, 6Gbps, or 12Gbps). The SoC identifies the video source by reading the packet's virtual channel or data type. If both sources use the same virtual channel or data type, the MAX96792A can assign a different virtual channel and/or data type (16 are available) if the part is operated in the pixel mode. The aggregated data can be replicated and output on both MIPI ports, allowing multiple SoCs to process the same data, as shown in [Figure 22](#).

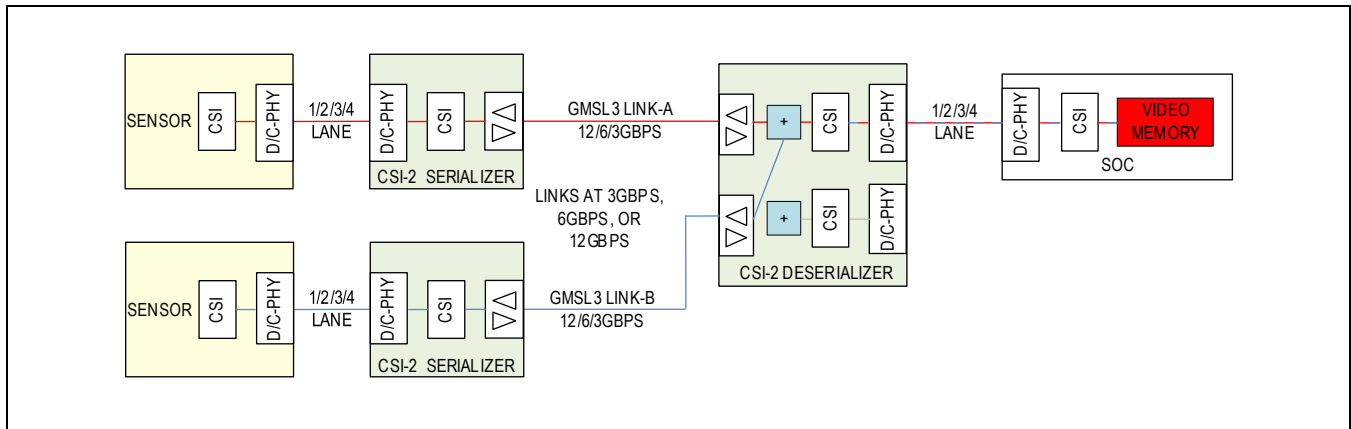

Figure 21. Dual Link, Data Aggregation

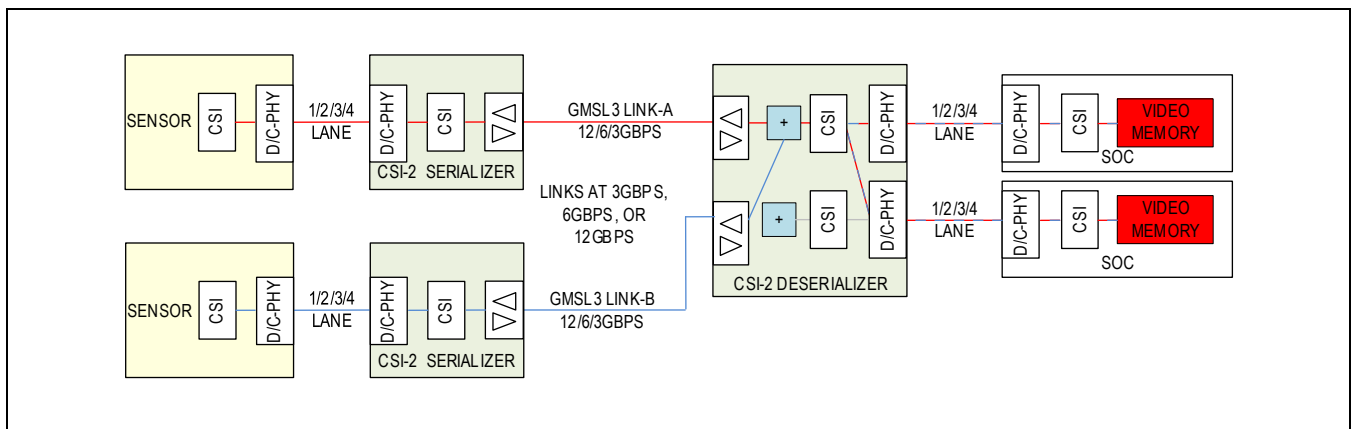

Figure 22. Dual Link, Data Aggregation and Replication

The MAX96792A is an ideal sensor deserializer when cameras are connected to an SoC with CSI-2 input. It also supports RADAR and LIDAR sensors, where a high-speed SPI is generally required.

### GMSL3 Overview

GMSL3 is a fixed-rate protocol designed to carry multiple types of communication channels concurrently. The link bit rate is based on a constant-frequency link clock generated from the 25MHz crystal oscillator or from an external reference frequency. The link clock is not related to the video pixel clock beyond the natural constraint that the video bandwidth cannot exceed the available link bandwidth.

GMSL3 uses a packet-based protocol to seamlessly share the link bandwidth between communication channels in a flexible way. Bandwidth allocation is dynamic so that if a certain channel is not active, it does not consume any link bandwidth, and all the remaining active channels can share the full link bandwidth. Maximum packet size is limited to prevent a single channel from utilizing the link bandwidth for an extended time. In most cases, available link bandwidth exceeds the bandwidth requirement. Idle packets are used to fill in the unused link bandwidth. The same data protocol is used on forward and reverse channels, and for both video and control-channel data.

GMSL3 supports a comprehensive suite of common embedded communication protocols. All devices utilize a primary I<sup>2</sup>C/UART control-channel interface that an electronic control unit (ECU) uses to access serializer and deserializer registers, as well as peripheral devices. This access can be initiated from either end of the link. Devices include two additional I<sup>2</sup>C/UART ports to access lower priority local registers or communicate with remote peripherals. These passthrough ports do not have access to the device registers.

An SPI main/subordinate is also included. The serial peripheral interface (SPI) enables a host SPI main on one side of the GMSL3 link to control a peripheral SPI subordinate on the opposite side. The host can be located at either end of the link or can swap ends by reprogramming the GMSL3 devices. A GMSL3 device can be configured as either an SPI main

or a subordinate. The SPI port functions exclusively as a pass-through port without access to serializer or deserializer registers.

All GMSL3 devices include a versatile suite of general purpose input/output (GPIO) pins that work with the GMSL3 peripheral communication protocols. In general, the GPIOs function as user-defined inputs or outputs, whose states can be either automatically forwarded across the link or controlled by register settings. GPIOs are typically used to tunnel low-speed (< 100Kbps) signals over the GMSL3 link, although they also support rates in excess of 1MHz. A GPIO tunnel can be set up in the forward or reverse direction.

GMSL3 provides extensive data integrity and safety features, including watermark generation/detection, cyclic redundancy check (CRC) error detection for control and video data, and error correction code (ECC) protection of video memory. Watermark generation and detection verify the video image is not frozen. CRC error detection identifies errors in the video or control-data streams. For control-channel CRC errors, automatic retransmission of the flagged packet maximizes control-channel speed and reliability. The internal video memory includes ECC protection to detect and correct internally-corrupted pixel data.

GMSL3 devices incorporate numerous link-margin optimization and monitoring functions that ensure high link margin and robust functionality. Continuous (1Hz) adaptive equalization optimizes link margin to adapt to environmental changes and cable aging. An eye-opening monitor function provides continuous link-margin diagnosis and includes various threshold alarm levels that trigger runtime alerts upon detecting link degradation. Pseudorandom binary sequencing (PRBS) checking verifies correct link and video channel operation.

#### **Link Error Generator**

Each GMSL link includes a configurable error generator that injects errors into the outgoing data stream immediately before transmission. The deserializer injects errors into the reverse channel and the serializer injects errors into the forward channel. The receiving device detects, counts, and flags the errors, enabling a thorough validation of the system's response to error conditions of varying severity.

#### **Video Pipeline in Pixel Mode**

The video channel receives and decodes video data received from the GMSL3 serializer and transports it to the CSI-2 output ports. It supports data types including RGB888, RGB666, RGB565, YUV422-8, RAW8, RAW10, RAW12, RAW14, RAW16, RAW20, user-defined, embedded, and null. Video input data consists of color, horizontal sync (HS), and vertical sync (VS) synchronous to the PCLK. Video flows through the design as described in the following sections.

#### **Watermarking**

The watermarking block detects a frozen frame failure in a frame-based processing system between the generator and detector. This feature specifically detects frozen frames caused by SoCs in safety-critical applications. It does not detect frozen frames that occur before the watermark generator or after the watermark detector. Most GMSL2 and GMSL3 devices contain both a watermark generator and detector. This allows both serializers and deserializers to insert or detect a watermark in a safety-relevant video stream. The watermark generator inserts a time-varying watermark that is highly redundant and robust to image processing and display stream compression. The watermark detector looks for this time-varying watermark, and failure to detect all the generated watermarks indicates a frozen-frame failure between the generator and detector in a frame-based processing system. Upon detection of this error condition, the watermark detector can generate an interrupt and/or blank the output video, returning the display to a safe state in less than 500ms.

#### **Video (Data) Line CRC**

The MAX96792A includes a 32-bit video-line CRC error checker to guarantee the integrity of each video line transported across the GMSL3 link. A video-line CRC is generated on the serializer side of the link, and is transferred over the link to the MAX96792A along with the corresponding video data. The MAX96792A compares the CRC received from the serializer with the CRC it generated for a given video line. Any discrepancy between the CRC codes indicates an error in the video data.

#### **Vertical and Data Enable or Data Valid Sync Outputs**

The MAX96792A can output the vertical sync (VS) and data enable/data valid (DE/DV) of a video stream to monitor video timing by a processor. This feature provides access to VS and DE/DV signals unavailable directly at the CSI-2 output. VS and/or DE/DV outputs are alternate functions of MFP0 and MFP3.

### Control-Channel and Side Channels

A  $\mu\text{C}$  or other controller can send and receive control and side-channel data over the GMSL3 serial link simultaneously with high-speed video data. The MAX96792A supports the following interfaces:

- Primary I<sup>2</sup>C/UART (internal access)
- Pass-through I<sup>2</sup>C/UART
- SPI
- GPIO
- All the above interfaces can pass data through the GMSL3 link, but the GMSL3 device registers can be accessed and configured only through the primary I<sup>2</sup>C/UART interface.

The side channel, with its various interfaces, is accessed using multifunction pins. Multifunction pins have a default function and can be programmed to an alternate function after power-up. Due to a practical limit in the number of pins available on a given device, not all interfaces can be simultaneously supported. See [Pin Descriptions](#) and [Table 14](#) for default and alternate multifunction pin functions, as well as available combinations of interfaces.

### Primary I<sup>2</sup>C/UART

The primary I<sup>2</sup>C/UART is located on the SDA\_RX and SCL\_TX pins of each GMSL3 device. The I<sup>2</sup>C (SDA, SCL) or UART (Tx, Rx) interface is selected by the CFG0 pin voltage at power-up (see [Table 12](#)). The selected interface provides main access to both GMSL3 registers and device registers from either end of the link.

The main microcontroller ( $\mu\text{C}$ ) can reside on either end of the link (usually the serializer side for display applications and deserializer side for camera applications). The MAX96792A supports dual main microcontrollers, provided that software arbitration (such as token passing) is used to prevent packet collisions. The control channel allows only one main  $\mu\text{C}$  to communicate at a time.

To configure peripheral devices over the link, the GMSL3 serializer and deserializer must use the same control-channel interface (both I<sup>2</sup>C or both UART). Unlike legacy GMSL1 devices, there is no I<sup>2</sup>C-to-UART conversion capability. I<sup>2</sup>C/UART outputs are open-drain and require appropriately-sized external pull-up resistors for proper operation.

For detailed main channel programming information, see the [Control-Channel Programming](#) section under [Applications Information](#).

### I<sup>2</sup>C/UART CRC and Message Counter

The MAX96792A provides additional functional safety by adding an optional CRC to I<sup>2</sup>C/UART read/write transactions and a separate message counter for read and write packets. These features are disabled by default and can be enabled by register programming. The CRC and message counter can be used together or individually. The CRC and message counter features only apply to device register read/write transactions and are not supported for pass-through traffic. The CRC and/or message counter can be enabled in the serializer, deserializer, or both.

The first CRC byte covers the data for the first 6 bytes: Device Address, Register Address MSB, Register Address LSB, Message Counter MSB, Message Counter LSB, and the first data byte. If there are multiple data bytes after the first byte, then a CRC byte is appended after each subsequent data byte. The CRC engine is reset to 0 after each CRC calculation is completed, meaning a fresh CRC calculation is done for each additional byte. The CRC polynomial for I<sup>2</sup>C/UART is  $P(x) = x^8 + x^6 + x^3 + x^2 + 1$ .

### Pass-Through I<sup>2</sup>C/UART

The MAX96792A has two pass-through I<sup>2</sup>C/UART channels. These channels do not have access to registers in either the GMSL3 serializer or deserializer; they simply tunnel the I<sup>2</sup>C or UART signal across the GMSL3 link. This allows I<sup>2</sup>C channels to be separated so that no multimain conflicts occur. I<sup>2</sup>C/UART outputs are open-drain and require appropriately-sized external pull-up resistors for proper operation.

### Serial Peripheral Interface (SPI)

The MAX96792A enables a host SPI main on one side of the GMSL3 link to control a peripheral SPI subordinate on the opposite side. Communication may be in either direction across the GMSL3 link.

The SPI clock range is 600kHz to 25MHz. Care must be taken to meet set-up and hold-time requirements when using at speeds higher than 20MHz. Set the speed rating for each MFP correctly for reliable operation. [Table 5](#) specifies the recommended drive strength and latching edge for the SPI as a function of SCLK speed.

**Table 5. SPI Latching Edge and Speed**

| FREQUENCY        | V <sub>DDIO</sub> | LATCHING EDGE       | PIOX_SLEW[1:0] |
|------------------|-------------------|---------------------|----------------|
| < 12.5MHz        | 1.7V to 2.24V     | Opposite from Shift | 01             |
|                  | 2.25V to 3.6V     |                     | 10             |
| 12.5MHz to 25MHz | 1.7V to 2.24V     | Opposite from Shift | 00             |
|                  | 2.25V to 3.6V     |                     | 01             |

### General Purpose Input and Output (GPIO)

The MAX96792A provides up to 13 GPIO/GPO/GPI, dependent on device feature utilization. GPIOs are typically used to tunnel low-speed (< 100Kbps) signals over the GMSL3 link, although it also supports rates in excess of 1MHz. A GPIO tunnel can be set up in the forward or reverse direction. MFP pins can be programmed as GPI, GPO (push-pull output), or ODO (open-drain output).

Each GPIO pin can be configured as an input, output, or input/output by programming the GPIO\_TX\_EN and GPIO\_RX\_EN register bits of each GPIO pin. Note that unwanted loop behavior is avoided for pins configured as input/output; when the pin is driven by a transition received from the remote side, the driven GPIO transition is not transmitted back. GPIO pins may alternately be controlled and read solely from registers.

Most GPIO pins can be programmed for 1MΩ or 40kΩ pull-up or pull-down (or none).

When a GPIO is programmed as GPO, the GPO can generally be programmed for open-drain or push-pull output.

A GPIO packet has 32 possible GPIO channel IDs. Each GPI is mapped to a channel ID according to the GPIO\_TX\_ID register. On the receiving end, each GPO outputs the received data with a programmed GPIO channel ID corresponding to the GPIO\_RX\_ID register for that pin. This provides flexibility in determining which GPIO input drives which GPIO output.

GPIO transmissions are transition-based: a GPIO packet is created and transmitted on the GMSL3 link when a rising-edge or falling-edge transition is detected at a GPIO pin. Several GPIO transitions at different GPIO pins can be grouped into a single packet. These pin transitions can be transmitted in two different modes: regular and delay-compensated.

The GPIO channel is not bandwidth efficient and should be used for low-speed signals only. Each GPIO transition uses 40 bits to 80 bits on the GMSL3 link for transmit and 40 bits to 60 bits on the reverse (due to received ACK packets). Bandwidth usage values vary based on channel configuration: automatic repeat request (ARQ) enable, CRC enable, and double-header enable, all impact channel bandwidth usage.

The state of each GPIO can be read or written by register, either locally or remotely, over the GMSL3 link by a μC using the control-channel I<sup>2</sup>C/UART interface. In non-delay-compensated mode, channel latency is not fixed. The GPI transition is sent as soon as possible, based on priority and available link bandwidth. This variable delay is a result of multiple communication channels sharing the link. Use non-delay-compensated mode with signals tolerant to delay variation (i.e. μC interrupts). Priority can be set for GPI pins using registers. If no priority is set, GPI transitions are transmitted in the order they occur. However, when priority is set, transitions on GPI with higher priority are transmitted earlier.

Typical GMSL3 device delays for forward-link and reverse-link rates are shown in [Table 6](#).

**Table 6. Typical GPIO Delays for Forward-Link and Reverse-Link Transmission**

| DIRECTION   | DELAY COMPENSATION (TX_COMP_EN) | DELAY |
|---|---------------------------------|-------|
| GPIO forwarding from serializer to deserializer (6/3Gbps forward channel)   | 0                               | 1µs   |
|   | 1                               | 3.5µs |
| GPIO forwarding from deserializer to serializer (187.5Mbps reverse channel) | 0                               | 6µs   |
|   | 1                               | 15µs  |

**Delay in Non-Delay-Compensated Mode**

In the non-delay-compensated mode, the value of the transition is transmitted along with the GPIO channel ID. Note that GPIO channel latency is not fixed; the GMSL3 link has variable delay as a result of multiple communication channels sharing the link. A maximum latency limit is established by the GMSL3 bandwidth-sharing scheme, but significant fluctuation remains. Use the non-delay-compensated GPIO mode with signals invariant to the delay variations (e.g., µC interrupts).

**Delay-Compensated Mode**

In the delay-compensated mode (also called jitter compensation or jitter minimization compensation), a timestamp value is transmitted in addition to the value of the transition and GPIO channel ID. This timestamp is a high-resolution value sampled by an internal 600MHz clock that records when the GPIO transition is detected at the input. The remote-side chip uses the timestamp value to wait and output the GPIO transition after a total fixed delay from the GPIO input transition. This method mitigates possible variable latency issues by making the total GPIO input-to-output delay a precise, fixed value. Use the delay-compensated GPIO mode for signals for which the relative timing of rising and falling edges are important (e.g., pulse-width modulation (PWM), camera frame-sync, radar ramp trigger, and low-speed universal asynchronous receiver-transmitter (UART) signals). The delay-compensated mode is enabled using TX\_COMP\_EN register fields for each GPIO.

**Frame-Sync**

In surround-view camera applications, the sensors usually require a frame-sync signal to synchronize the output of a frame with the other cameras in the system. Most GPIOs can be configured as GPI and linked to a frame-sync signal generated by a surround-view camera ECU.

**Control-Channel Retransmission on Error****Automatic Repeat Request/Automatic Retransmission (ARQ)**

Communications channels with control data (I<sup>2</sup>C/UART, GPIO, SPI) are relatively low bandwidth, but require the highest data-integrity protection. An optional automatic packet retransmission method, ARQ, is employed here. ARQ works in conjunction with 16-bit packet CRC to detect if packets are received without error.

Packets are appended with a 2-bit sequence number at the transmit side and an acknowledge packet is sent from the receiver side upon successful receipt of each data packet. These packets are stored on the transmit side until acknowledged. If the acknowledge packet does not arrive in a predetermined interval, or the sequence number of the acknowledge packet does not match the expected value, the packet waiting at the top of the queue is automatically retransmitted.

The acknowledge packet uses the same header field as low-bandwidth packets, but begins with a different special symbol to distinguish it from regular data packets. This simplified format keeps retransmission exchanges independent from the communication channel. Note that this smaller packet format contains no data, obviating the need for full 16-bit CRC. Instead, the header symbol is sent twice in the packet, and the instances are checked against each other to ensure a match. The acknowledge packets also include a 2-bit sequence number that is the same sequence number of the correctly received data packet. The data packet transmitter tracks the acknowledged packets.

## Other Functions

The devices include a video crossbar. The crossbar can be used to reorder the color and sync signals.

GMSL3 devices incorporate numerous link-margin optimization and monitoring functions to ensure high link margin. Continuous (1Hz) adaptive equalization (AEQ) optimizes link margin to adapt to environmental changes and cable aging. An eye-opening monitor function for continuous link-margin diagnosis with various threshold alarm levels is available for runtime alerts of link degradation. PRBS checking verifies correct link and video-channel operation.

## Tunnel and Pixel Modes

The MAX96792A is specifically designed for advanced driver assistance systems (ADAS) where data integrity is a key safety requirement. Prior GMSL2 solutions supported only Pixel mode for transporting received data from a MIPI CSI-2 interface over the GMSL link.

In Pixel mode, the received CSI-2 data is depacketized at the serializer's CSI-2 input interface. The received CSI-2 packet header includes an error correction code (ECC), which is checked and removed at the serializer input. The received CSI-2 packet footer contains the CSI-2 cyclic redundancy check (CRC), which is also checked and removed.

Video line pixel data and video routing information, such as data type and virtual channel, are received and extracted at the CSI-2 interface. Both video pixel data, control channel data and routing information are input to a scheduler in the serializer. The scheduler packetizes and encapsulates the data using GMSL protocol and sequences data transmission across the GMSL link. Video data transport across the GMSL link is protected by line CRCs that are part of the GMSL protocol.

The deserializer receives the GMSL packets and verifies the GMSL2 line CRCs. A CSI-2 interface at the deserializer output encapsulates each video line using CSI-2 protocol and outputs it in CSI-2 format across a CSI-2 interface to the SoC. See [Figure 23](#).

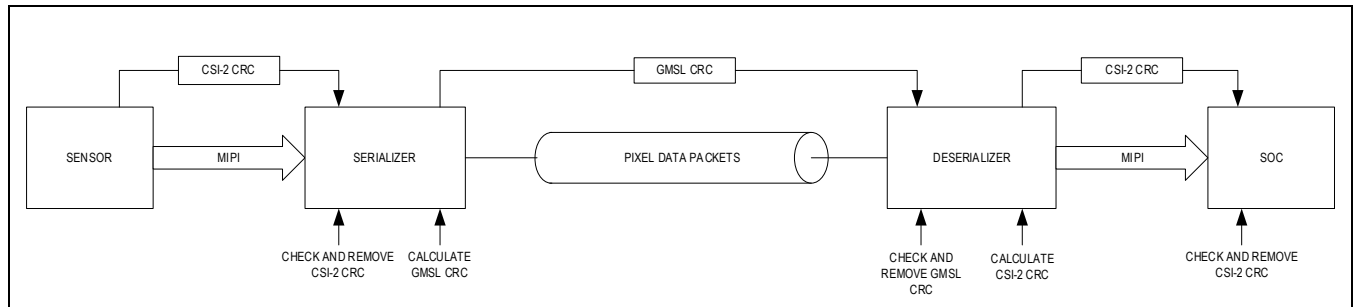

Figure 23. Pixel Mode

In Tunneling mode, the received CSI-2 ECC byte and CRC bytes are checked at the serializer input. These, as well as routing and pixel data, are received as a byte stream. The byte stream is split into smaller packets that are encapsulated using GMSL2 protocol.

The serializer adds a line CRC protecting transmission across the GMSL channel. This CRC covers the entire GMSL2 packetized byte stream for a video line. See [Figure 24](#). The deserializer receives the transmitted GMSL2 packets and control channel packets, checks and removes the GMSL CRC, separates video data from control data, and reconstructs each received CSI-2 packet that is the output to the SoC on a CSI-2 interface. A CRC is calculated on the video data output on the CSI-2 interface. This CRC is compared by the deserializer to the original CRC received from the video source. This comparison guarantees that the entire data packet output on the standard MIPI interface is identical to that received at the serializer input. Tunneling mode is more bandwidth-efficient if multiple data types are being sent. Because data received at the serializer input and data output from the deserializer are verified to be identical, Tunneling mode does not allow for processing of the video data, such as watermarking or lossy data compression. Different data rate and different lane count on serializer and deserializer are still possible.

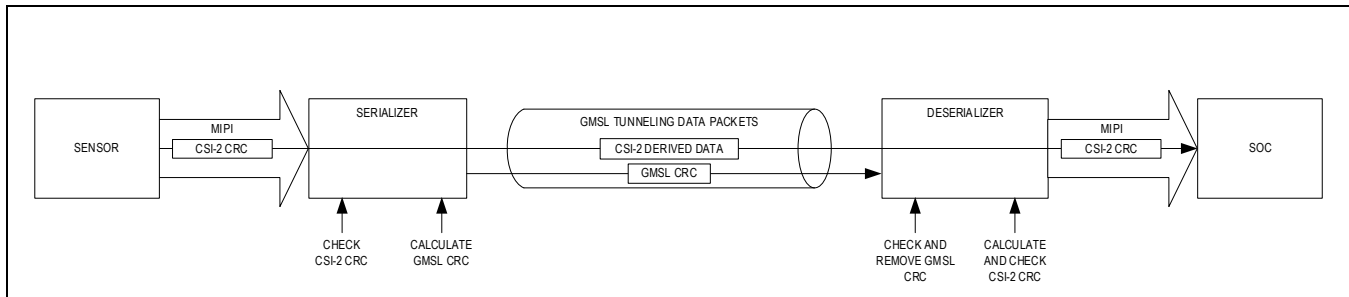

Figure 24. Tunnel Mode

### Forward-Error Correction (FEC)

The MAX96792A supports a Reed-Solomon FEC for added link robustness. The Reed-Solomon encoding adds a 6-bit correction word to every 121 bits of data for an effective throughput of 93.3% in return for a bit error rate (BER) reduction from  $10^{-15}$  to  $10^{-55}$ . The maximum payload of the 12Gbps GMSL3 link with FEC is 9.7Gbps. The primary need for FEC in GMSL3 products arises from higher bit-rates and higher-loss links (longer cables, more connectors). FEC is required for GMSL3 mode using PAM4 signaling (12Gbps), but is an option for GMSL2 mode (6Gbps or 3Gbps) using Non-Return to Zero (NRZ) signaling.

The FEC block processes data in blocks of 128 symbols. Each symbol is 18 bits wide. It is possible to correct up to three symbol errors (up to 54 bit errors if the errors are a continuous burst) detected in a block of 2,560 bits. If the number of errors in a block are higher, there are uncorrected errors. These errors are flagged by the CRC part of the FEC block. The FEC block contains error counters, both for corrected and uncorrected errors, and the FEC input bit-error rate is a good indication of link quality. Keep the FEC input BER  $< 10^{-7}$  for error-free operation.

#### Features:

- Burst error correction capability equivalent to two to three link symbols.
- Debug capability to enable analyzing quality of received data.
  - Number of errors corrected, number of uncorrectable errors.
  - Interrupt output when uncorrectable errors exceed threshold.

#### Notes:

- Correction is available for all data traffic in the GMSL lanes supporting FEC.
- Enabling FEC reduces the available bandwidth by 6.7%.
- FEC adds approximately 4300 UI latency to the link.
- When FEC is used, it must be on in both the serializer and deserializer.

### Functional Safety Features

The MAX96792A integrates a number of safety features, including power-on-self test (POST), which includes logic built-in self test (LBIST), memory built-in self test (MBIST), and a power manager that reports undervoltage/overvoltage conditions. The host interface (I<sup>2</sup>C/UART) has an optional CRC capability and optional Message Counter for I<sup>2</sup>C/UART traffic.

At power-up, LBIST verifies that key logic blocks are correctly functioning and free of latent faults. MBIST checks the line-buffer memories to ensure data is stored correctly before being sent to the MIPI output ports. The POST produces a pass/fail result that can be read through a register for each test. A POST failure on start-up does not prevent the device from operation, but is reflected in registers POST\_LBIST\_PASSED and POST\_MBIST\_PASSED.

A register CRC (REGCRC) detects unintended changes in the configuration registers. A CRC value for the configuration registers is computed and stored on demand at start-up. During operation, the REGCRC block periodically calculates the CRC of the configuration registers and compares the calculated value to the stored value. A mismatch can be reported through ERRB.

## GMSL3 Physical Layer

Analog Devices' GMSL3 serial link family has transmitter and receiver capabilities enabled simultaneously, allowing full - duplex operation on a single wire. A single cable between the serializer and deserializer delivers data transmitted from each end of the link. Forward transmission refers to data sent from the serialzier to the deserializer. Reverse transmission refers to data sent from the deserializer to the serializer.

Fixed forward rate options of 3Gbps, 6Gbps, or 12Gbps are available for both coax and STP. The reverse rate is fixed at 187.5Mbps.

### Cabling Options

MAX96792A devices support either 50Ω coax or 100Ω STP cabling. Cable attenuation and return loss characteristics must stay within the requirements of the GMSL3 channel specification to achieve robust full-duplex link performance. These requirements vary with selected link rate. The available link rates and adaptive equalization support a wide range of cabling options.

Coax or STP mode and data rates are configured upon start-up and determine which cabling option applies. In Coax mode, use only the noninverted SIO pins. AC-couple and terminate the unused SIO pins using the series connection of a 100nF capacitor and a 49.9Ω resistor. In the STP configuration, both the noninverted and inverted pins are enabled by default.

Maximum cable length is limited by the frequency-dependent attenuation of the cable. Additionally, PCB and inline connectors degrade the return loss characteristic of the cable assembly. The GMSL3 channel specification allows two inline connectors, and provides detailed requirements for cable attenuation and return loss, as well as insertion loss and return loss requirements for PCB traces. In general, any physical channel implementation compliant with the GMSL3 channel specification can be used with reliable results. Contact the factory for the GMSL3 channel specification document.

Coax or STP operation of the GMSL inputs is determined by the level of CFG1 pin at power-up. The GMSL links are configured the same by default, but can be changed after power-up by register programming. See [Table 13](#).

### GMSL3 Bandwidth Sharing

The GMLS forward link bandwidth is shared flexibly between different communication channels requesting the link for packet transmissions. This flexibility comes from packet-based transmission format and dynamic bandwidth allocation: if a certain channel is not active, it does not consume any link bandwidth, leaving the full link bandwidth available for all active communication channels to share. The packet-based protocol fulfills this sharing requirement. The maximum non-video packet size is limited to 64 words to prevent one channel from monopolizing the link bandwidth and ensure other channels are served. Other bandwidth-sharing mechanisms are discussed in the following section.

A bandwidth sharing scheme is employed for multiple pending requests of the same priority setting to avoid creating buffer overflows. Without bandwidth sharing, a burst data request from a channel can cause buffer overflow in other communications channels on the link. Bandwidth sharing, however, considers predefined bandwidth share ratios and recent bandwidth usage averages of each type of communication channel to avoid buffer overflows and ensure all channels are served.

The arbiter continuously measures the bandwidth usage of each channel and filters the data according to analysis of the moving averages. This data is then compared to assigned bandwidth share ratios. To ensure link bandwidth parity, the arbiter takes this recent bandwidth usage information to decide which channel is allocated to use the link for each new packet transmission request. Consider a link allocated for either video or SPI communications, where video is assigned 90% link share and SPI is given 5% share. A burst SPI transmission request on this link can cause video overflow buffering if the SPI bandwidth share exceeds 10% of the total. To avoid video buffering, SPI is allotted no more than 10% of the link to preserve the remaining 90% for video communications.

### GMSL3 Bandwidth Calculations

The GMSL3 forward link has a fixed link rate of 3Gbps, 6Gbps, or 12Gbps. The reverse link rate is also fixed at 187.5Mbps. The GMSL3 protocol and line coding overhead is roughly 14%. Forward-error correction, used for 12Gbps forward rate, adds 6.7%. This leaves approximately 2.6Gbps, 5.2Gbps, or 9.7Gbps of data throughput in the forward direction, and 162Mbps in the reverse direction.

Ensure the worst use cases do not exceed the available throughput of the forward and reverse links. Analog Devices' evaluation kit (EVK) GUI includes a bandwidth (BW) calculator for initial bandwidth requirements estimates. Analog

Devices also has other tools to calculate link bandwidth utilization. Consult the factory for high-bandwidth use cases for error-free performance. See [Figure 25](#) for definitions of terms.

[Table 7](#) provides estimates of the bandwidth utilization for each communication channel.

**Table 7. Forward- and Reverse-Link Bandwidth Utilization**

| DATA                      | APPROXIMATE BANDWIDTH UTILIZATION  |
|---------------------------|--|
| Video (Forward Path Only) | $H \times V \times \text{fps} \times \text{bpp} \times (1 + (\% \text{ horizontal blanking})/100 + (\% \text{ vertical blanking})/100) \times 1.16$<br>Maximum bandwidth is limited by pixel clock rate PCLK.<br>Pixel mode: PCLK = MIPI data rate/bpp<br>Pixel mode (double pixel mode): PCLK = MIPI data rate/(2* <i>bpp</i> )<br>Tunneling mode: PCLK = MIPI data rate/24<br>Maximum PCLK = 600MHz for 6Gbps or 12Gbps link rate<br>Maximum PCLK = 300MHz for 3Gbps link rate |
| I <sup>2</sup> C          | 18 to 60 x I <sup>2</sup> C clock rate, depending on available link bandwidth  |
| UART                      | 6 x UART bit rate, 5.5 x when parity bit enabled   |
| SPI                       | 2.5 x SPI rate   |
| GPIO                      | 60 x GPIO transition rate without delay compensation<br>80 x GPIO transition rate with delay compensation  |

Note: Bandwidth utilization for all control-channel and side-channel communication increases by 6.7% when FEC is enabled. FEC is required for 12Gbps operation.

Definitions:

H = Horizontal resolution

V = Vertical resolution

fps = Frames per second

bpp = Bits per pixel

MIPI data rate = Aggregate data rate of all lanes in the MIPI

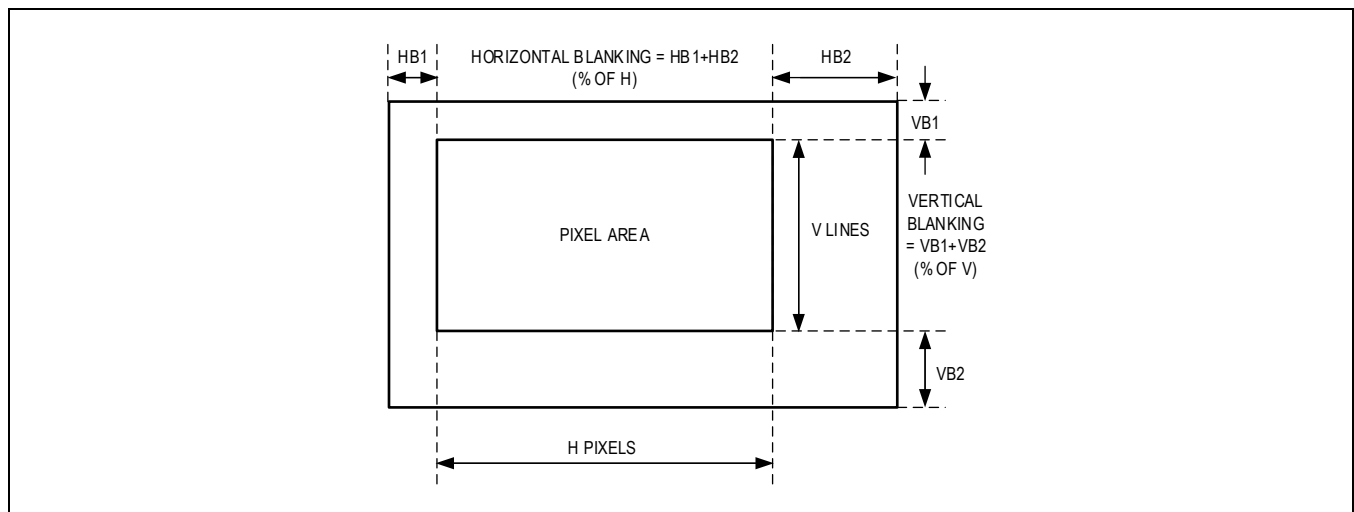

Figure 25. Video Frame Format for Bandwidth Calculation

### Eye-Opening Monitor (EOM)

The EOM enables GMSL2 parts to monitor the link margin on an active link and generate an interrupt if it falls below an acceptable level. For example, if a cable is damaged, the link can run error free, but have less link margin than desired. This allows proactive reaction to deteriorating cable performance before any link errors occur. GMSL2 devices can measure the horizontal or vertical eye opening of the equalizer's output. The measurement is activated automatically at a  $\sim 1\text{Hz}$  rate once a link is active. The EOM block compares the data sampled at the center of the eye with a sample offset in phase for the horizontal EOM or offset in voltage for the vertical EOM. The eye-opening is then reported, and the EOM can trigger an interrupt or a reset if the opening falls below user-defined thresholds. Note that the EOM is a recommended diagnostic for GMSL2 mode (3Gbps or 6Gbps), not for GMSL3-mode (12Gbps).

### Line-Fault

GMSL deserializers include a novel line-fault detection circuit. It detects and reports open-circuit, short-to-battery, short-to-ground, and line-to-line short. The line-fault monitor requires external resistors  $R_{EXT1}$  and  $R_{PD}$  in Coax mode, and  $R_{EXT1}$ ,  $R_{EXT2}$ , and  $R_{PD}$  in STP mode connected to the LMN\_ pins as detailed in the following sections.

The line-fault monitor is disabled by default, configuration options are available through registers, and status can be read by the register. If unmasked, a line-fault condition asserts ERRB. Line-fault detection cannot be used in conjunction with Power-over-Coax (POC) or AC-coupled ground applications. The line-fault monitor pins offer flexible connection and programming in either Coax or STP applications.

[Figure 26](#) illustrates the two configuration options for the location of line-fault detection. The Local-Side Serializer Configuration is typically used for display links and Local-Side Deserializer Configuration for camera links; however, either configuration can be used on any device serial link system. Additionally, either applies to Coax or STP mode.

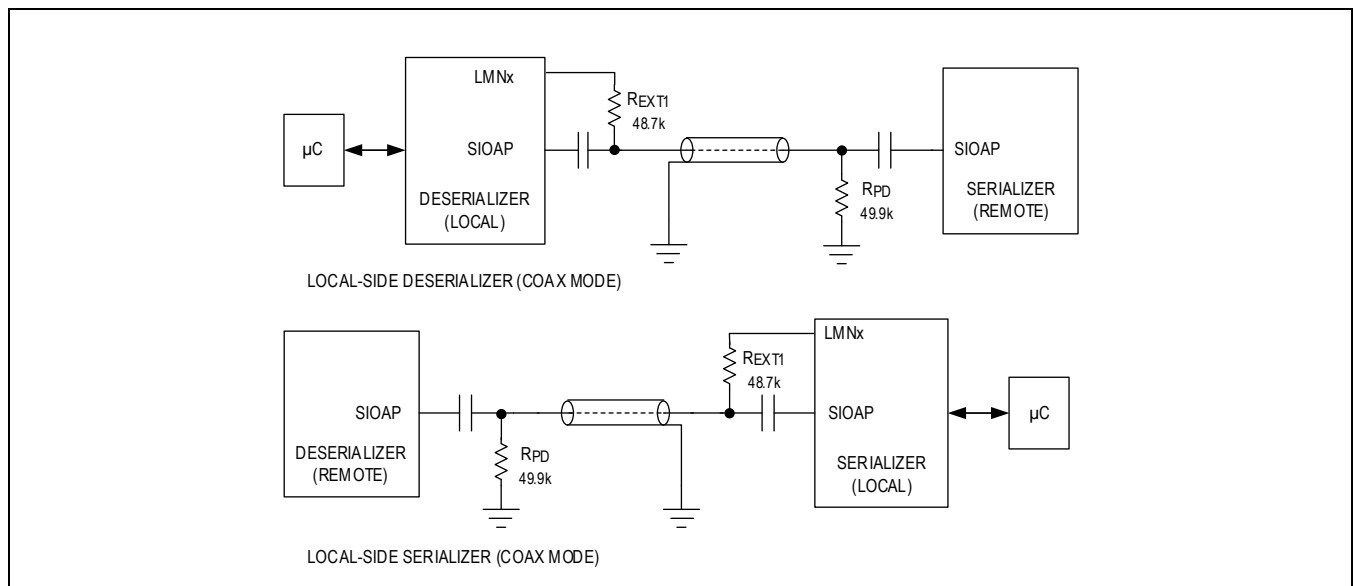

Figure 26. Line Fault Detection Location Options

The LMNx pins (LMN0 to LMN3) are typically mapped to different multifunctional pins on each unique part and package options. Some parts may have up to four line-fault detectors, depending on the package options and pin availability.

**Coax Mode**

In Coax applications, any LMNx pin can be used. The local side sources the line-fault. The local-side device requires a single 48.7kΩ resistor ( $R_{EXT1}$ ) connected directly from any of the LMNx pins to the serial link.  $R_{EXT2}$  is not used in Coax applications. The remote side of the serial link requires a 49.9kΩ resistor ( $R_{PD}$ ) connected from the serial link to GND. Any of the line-monitor pins can be used in Coax applications.

**Table 8. Coax Mode Line-Fault Configuration Options**

| SIGNAL         | SIOAP              | SIOBP              |
|----------------|--------------------|--------------------|
| Line-Fault Pin | LMNx (any LMN pin) | LMNx (any LMN pin) |
| $R_{EXT1}$     | 48.7kΩ             | 48.7kΩ             |

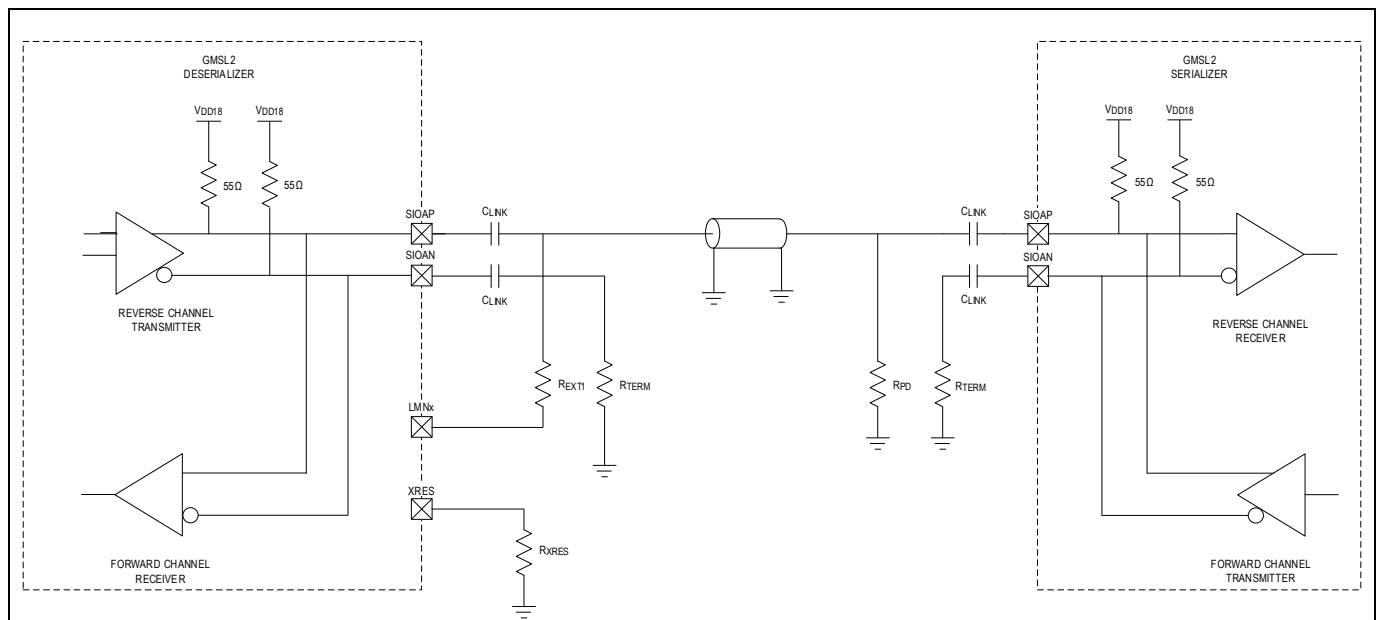

Figure 27. Typical GMSL Link Application Circuit for Coax Cable

**STP Mode**

If the serial link is operating in Twisted-pair mode, connect one line to an even-numbered pin (LMN0/2) and other line to an odd-numbered pin (LMN1/3) on the local side. For reliable line-fault detection, the even-numbered pins (i.e., LMN0 and LMN2) must be connected to the line using a 42.2kΩ resistor ( $R_{EXT2}$ ); the odd-numbered pins (i.e., LMN1 and LMN3) must use a 48.7kΩ resistor ( $R_{EXT1}$ ) to connect to the line (as with single-ended mode)). On the remote side, both lines require a 49.9kΩ resistor ( $R_{PD}$ ) connected to GND.

For full operation of line-fault detection in twisted-pair applications, use either LMN0/1 or LMN2/3 pairs. This pairing is required for proper operation of the line-to-line short detection; however, this pairing is not necessary for the detection of other fault conditions.

Line-Fault Pair #1 (LMN0/LMN1) Resistor Values and Connection Choices in STP Mode

**Table 9. STP Mode Line Fault Configuration Options for LMN0/LMN1**

| LINE FAULT PAIR #1: LMN0 AND LMN1 | SIOAP                                    | SIOAN                                    |
|-----------------------------------|--|--|
| Option #1                         | LMN0: $R_{EXT2}$ = 42.2kΩ to serial link | LMN1: $R_{EXT1}$ = 48.7kΩ to serial link |
| Option #2                         | LMN1: $R_{EXT1}$ = 48.7kΩ to serial link | LMN0: $R_{EXT2}$ = 42.2kΩ to serial link |

Line-Fault Pair #2 (LMN2/LMN3) Resistor Values and Connection Choices in STP Mode

**Table 10. STP Mode Line-Fault Configuration Options for LMN2/LMN3**

| LINE FAULT PAIR #2: LMN2 AND LMN3 | SIOAP   | SIOPN   |
|-----------------------------------|---|---|
| Option #1                         | LMN2: $R_{EXT2} = 42.2k\Omega$ to serial link | LMN3: $R_{EXT1} = 48.7k\Omega$ to serial link |
| Option #2                         | LMN3: $R_{EXT1} = 48.7k\Omega$ to serial link | LMN2: $R_{EXT2} = 42.2k\Omega$ to serial link |

Identical options apply to the GMSL B-port (SIOBP and SIOBN pins).

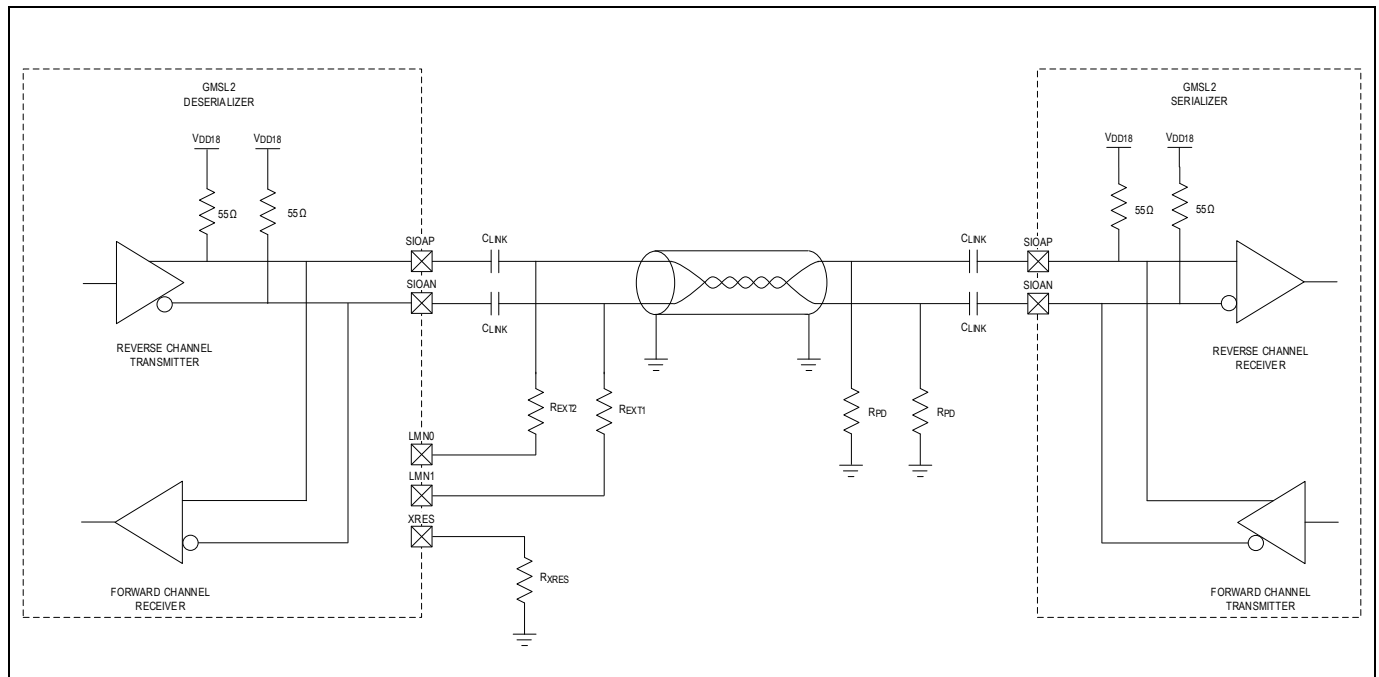

Figure 28. Typical GMSL Link Application Circuit for Twisted Pair (Line-Fault Pair #1: LMN0 and LMN1, Option #2)

### Adaptive Equalization (AEQ)

The GMSL3 devices automatically adapt the forward path receiver characteristics to compensate for insertion loss and return loss characteristics of the channel, which consist of the cables, connectors, and PCBs. This approach optimizes performance on any channel that meets the GMSL3 channel specifications.

The equalizer architecture makes GMSL3 links robust against noise, crosstalk, and reflections. Initial adaptation is performed during link lock and then invoked at a rate of approximately 1Hz to track temperature and voltage variations. The adaptation process optimizes the equalizer coefficients to maximize the eye-opening by using the built-in eye opening monitor.

### Video Pipes

In the GMSL3 Pixel mode, the transportation of video data is based on the concept of video pipes. Carrying data in pipes allows GMSL3 to bridge different digital video interfaces (i.e., parallel YUV422 source to CSI-2 sink), and perform watermark generation and detection. A pipe carries a video stream (or streams) and video synchronization data, and operates in one of three modes. In all modes, a pipe can carry multiple concurrent video streams, with each stream having different virtual channels and data types as follows:

- Mode 1: Streams with constant bits per pixel (bpp) of up to 24bpp. The bpp of the streams must be the same.
- Mode 2: Streams with 16, 14, 12, 10, or 8bpp. Streams less than 16bpp are padded with zeros.
- Mode 3: Streams with two different bpp rates. The bpp of one stream must be twice the bpp of the other stream. The highest bpp stream is 24bpp.

Modes 1 and 3 carry data at full bandwidth, but put more restrictions on bpp than Mode 2. Mode 2 allows streams with different bpp rates, but streams of less than 16bpp are carried using more bandwidth than necessary on the GMSL3 link (because of zero-padding). Mode 1 or 3 is sufficient for most applications. Mode 2 requires less programming and is more convenient if the application does not require maximum link bandwidth.

The MAX96792A has two video pipes, one for each GMSL3 port. Each of the two pipes has a dedicated video-line buffer. Each 32k byte (256kb) video-line buffer has the capacity for a line length of up to 4,096 24-bit pixels in pixel mode and 5,461 24-bit pixels in tunneling mode (line blanking pixels not included in both modes). The number of pipes used by all serializers connected to the MAX96792A cannot exceed two pipes.

Before data enters a line buffer, it goes through a crosspoint switch and a DT and VC reassignment stage. If the video source has a CSI-2 output, packet DT and VC can be left as-is or reassigned through register programming. Up to 16 DT/VC incoming pairs can be mapped to 16 DT/VC outgoing pairs.

If the video source does not have a CSI-2 output, a DT and VC can be programmed in the MAX96792A for insertion into the CSI-2 output packet. The crosspoint switch can change the order of the bits in the incoming video pixel data to any order, if desired.

A line buffer stores a complete line of video data before the data is available for readout by an aggregator. Each buffer connects to two aggregators, but only one aggregator (as programmed by the user) can read a line of data out of the buffer at a time. Once data is read out, it cannot be read out a second time by the same aggregator or by the other aggregator. However, in a time-domain multiplexed fashion, both aggregators can be programmed to read from the same buffer.

Data is read out from line memory on a first-come, first-served basis. When a complete line of data has filled a line memory, it is read out. The order in which the line memories reach filled status is the order in which they are read out.

In Pixel mode, video data can be routed according to DT or VC, based on the source CSI-2 packet's DT/VC, or by a DT/VC assigned or reassigned by the MAX96792A. For example, data in Pipe Y with VC0 can be programmed to be read out by Aggregator A, while data in Pipe Y with VC1 can be programmed to be read out by Aggregator B. In Tunneling mode, data cannot be routed by VC or DT, but is simply sent to the programmed aggregator.

The aggregator forwards the line of video or data from the line buffer, and video-synchronization data to its associated CSI-2 controller for packet generation. Packets can be output on the controller's port or replicated by routing them to the other port. For example, CSI-2 Controller 0 can output packets on D-PHY Port A or also route them for output of D-PHY Port B.

A D-PHY or C-PHY port can only accept packets from one controller; it cannot aggregate packets from the two controllers.

To prevent buffer overflow, program the CSI-2 port data rate to a rate equal to or greater than the incoming data rate. Programming the output rate to be faster than the bandwidth of the incoming video or data increases packet spacing (LP time between packets).

No reformatting of the data occurs in Tunneling mode. It is a requirement for functional safety that the video data is unchanged, such that it can be compared against the tunneled CSI-2 CRC by the host.

After data exits a retiming buffer, it goes through a crosspoint switch, and a DT and VC reassignment stage. If the video source has a CSI-2 output, packet DT and VC can each be left as-is, or reassigned by register programming.

[Figure 29](#) shows the MAX96792A operating with the input data from each input port kept separate, while [Figure 30](#) shows the ability to combine the data from each input port onto both output ports.

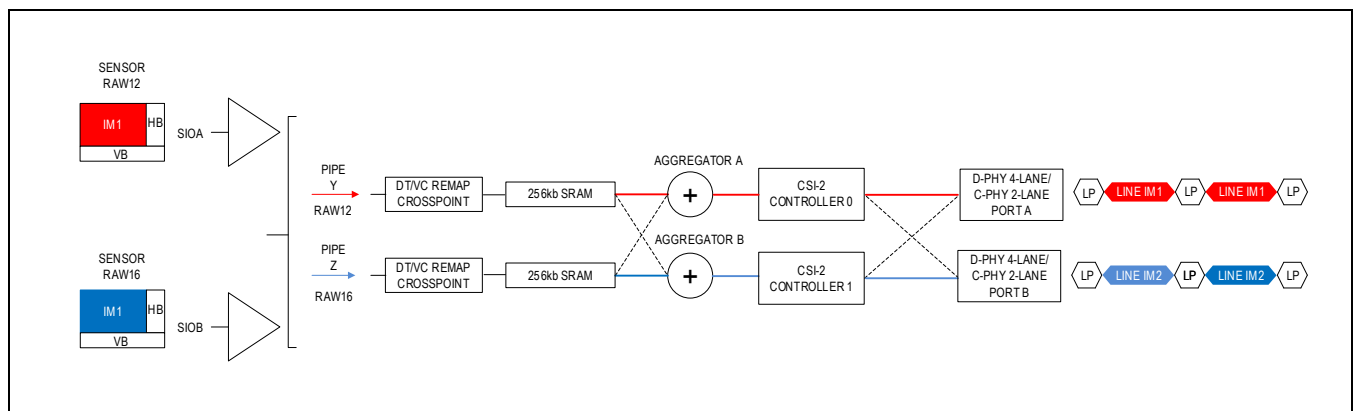

Figure 29. GMSL3 Video Output of Separate Ports

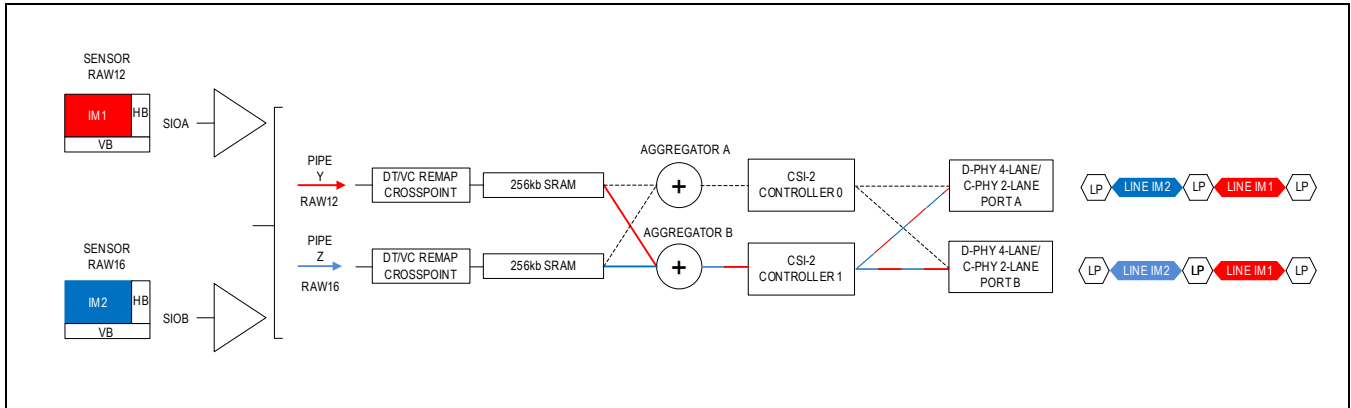

Figure 30. GMSL3 Video Aggregated and Replicated

**Video-Timing Generator (VTG)**

The VTG can substitute HS, VS, and DE signals with the signals it generates as defined by the configuration registers. The VTG can generate almost any type of SYNC-signal set pattern in various modes to start the generated patterns. With proper register programming, it is possible to generate any desired PCLK output frequency without an attached serializer. The VTG can generate a test pattern at any resolution with internally-generated clocks.

**RGB888 Video-Pattern Generator**

The built-in RGB888 VPG can be used for debug purposes. Video of any resolution can be generated by the VPG without a GMSL connection, or video from the peripheral can be replaced by the video-pattern generated by the VPG as programmed from the configuration registers (see PATGEN\_1 register block). The VPG can generate checkerboard and gradient patterns using RGB888 data. The pixel clock for the VPG is sourced internally and is configured using the following registers:

**Table 11. Video-Pattern Generator Pixel Clock Selection**

| 0x38[1] | 0x38[0] | 0x1FC[7]<br>PATGEN_CLK_SRC | PIXEL CLOCK (MHz) |
|---------|---------|----------------------------|-------------------|
| 0       | 0       | x                          | 25                |
| 0       | 1       | x                          | 75                |
| 1       | x       | 0                          | 150               |
| 1       | x       | 1                          | 600               |

**Pseudorandom Binary Sequence (PRBS)**

**Video PRBS**

The video channel of the serializer implements a PRBS pattern generator that operates with bit-error verification in the deserializer to test channel operation. The PRBS generator works with the clock received from the source.

**Link PRBS**

The link PRBS test is an evaluation tool to validate error-free operation across the GMSL channel using a PRBS-7 data pattern. It can be useful for the prototyping and verification phases of the GMSL SerDes devices.

The link PRBS floods the entire link bandwidth with PRBS-7 data. Regularly packetized data such as video and control channel commands cannot be sent during the test. Once the test is enabled, the control channel is lost, and remote communication is unavailable. To properly operate the link PRBS test, access to both local and remote device registers is required without the serial link as the control-channel transmission medium. This can be achieved only by accessing the control interfaces on both the serializer and deserializer to configure the link PRBS generator/checker on each end of the link.

### Video-Memory ECC Protection

The integrity of data propagating through the video pipeline's memory is guaranteed by ECC, which corrects 1-bit errors and detects 1-bit or 2-bit errors per 32 bits of video data. This functionality provides protection of data unprotected by the CRCs of the incoming GMSL stream or outgoing camera serial interface (CSI) stream, eliminating the possibility that internally-generated bit errors might corrupt the outgoing CSI-2 stream. The state of the ERRB pin can be used to detect the presence of errors. Intentional memory-error injection is available for diagnosis.

### Scheduler/Arbiter

A scheduler transmits packets with high priority values before lower priority values. Each communication transmit adapter sets a priority for the packet request before transmitting data to the remote side. The priority value is 2 bits, which allows for the following settings: 0 = low, 1 = normal, 2 = high, and 3 = urgent. The scheduler, provided sufficient link bandwidth, chooses to transmit the packet with the highest priority among the pending active requests. Priority levels become more important as link bandwidth becomes scarce. Assign prioritization accordingly.

In most cases, each transmitter adapter should use the normal priority setting (priority = 1) to allow the scheduler to choose the transmission schedule based on recent bandwidth usage. Packet priority can be increased if packets require low latency or have waited for a specified period of time. For example, packets with requirements on maximum latency can have increased priority if the packet request is not serviced until half of the maximum latency requirement has elapsed. This can also be used for communications channels with continuous data flow (e.g., video). Priority can be increased when the transmit adapter data buffer approaches overflow. Conversely, register configuration allows the priority settings of each channel to be overridden. This option is useful if the host  $\mu$ C wants to prioritize one channel over the others.

Communications channels with very relaxed latency requirements can use the low-priority setting (priority = 0). These low-priority packets are not serviced by the scheduler if there are any pending requests of a higher priority setting. In this arrangement, link-bandwidth assignment can reach the theoretical maximum for video. Low-priority packets can then be transmitted during video horizontal-blanking time, during which the video-channel bandwidth usage drops considerably.

### Control-Channel CRC Generation and Checking

Every packet (excluding idle and acknowledge packets) can be protected by a 16-bit packet CRC. Each packet type can be individually configured to enable or disable packet CRC. By default, all control-channel packets transporting I<sup>2</sup>C, UART, SPI, or GPIO data have packet CRC. For the forward control-channel, the CRC is generated for each controlchannel packet transported across the link to the deserializer. In the deserializer, a CRC is calculated based on the packet content and is compared to the received CRC. A mismatch results in automatic retransmission of the packet. Similarly, for the reverse channel, the CRC is generated in the deserializer and checked in the serializer. A mismatch results in automatic retransmission of the control channel packet.

For a GPIO, each packet transmitted across the link represents a GPIO transition and its routing information. Thus, each transition results in a 16-bit CRC being transported across the link, adding to bandwidth consumption.

Note that as acknowledge packets contain no data and the header is repeated, CRC is unnecessary.

The 16-bit packet CRC generator polynomial is:  $x^{16} + x^{15} + x^2 + 1$ .

## Serial Peripheral Interface (SPI)

The MAX96792A includes one SPI bridge, enabling a host SPI main on one side of the GMSL3 link to control a peripheral SPI subordinate on the opposite side. Communication can be in either direction across the GMSL link.

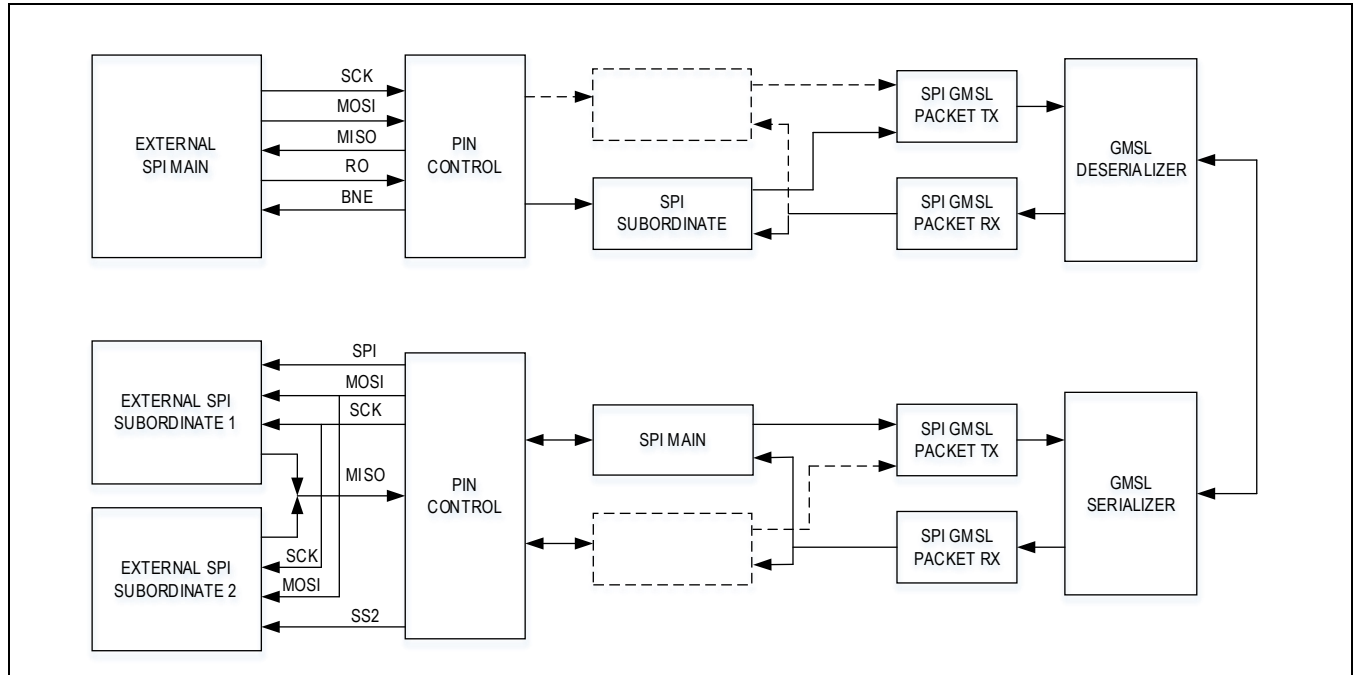

Figure 31. SPI Bridge

## CSI-2 Output Interface

### Lane Configurations and Data Rates

Video data is output to unidirectional MIPI CSI-2 v1.3 output ports. Each port can be configured to use either D-PHY v1.2 or C-PHY v1.0. The interface offers a high degree of flexibility. When configured as D-PHY, each interface supports either one, two, three, or four differential lanes. Up to four lanes on each port are supported if the part is configured to use one or two ports. When configured as C-PHY, each port supports either one or two lanes/trios. To ease PCB layout, lane swapping is supported independently of the number of lanes used. For example, when the device is configured to enable a single lane, that lane can be any one of the four lanes available within that port. If two lanes are enabled, those two lanes can be any two lanes within the port. Lane polarity swapping within a lane is also supported.

### CSI-2 Virtual Channel and Data Type Interleaving

The device supports virtual channels, including virtual-channel extension (VCX) introduced in CSI-2 v2.0, enabling up to 16 virtual channels.

### Video PRBS Generator/Checker

GMSL3 devices include built-in video PRBS generators/checkers for video link testing. For example, a serializer's PRBS generator can be used in conjunction with a deserializer's PRBS checker to test the GMSL2 video channel that connects the two devices. In this case, the MAX96792A's PRBS checker functionality compares the received PRBS stream with the predicted PRBS data to establish any errors.

The MAX96792A also includes the video PRBS generator functionality to test downstream video devices that receive video through the MAX96792A's CSI-2 output. This includes GMSL serializers connected in a loopback configuration with CSI and GMSL video paths being tested at the same time.

Note that all link bandwidth is not used by the video channel alone. So, it is possible to have a bit error on the link that does not cause a video PRBS error.

To run the video PRBS test, first enable the PRBS generator on the transmitter side, then enable the checker on the receiver side. The PRBS checker automatically syncs itself to the incoming PRBS pattern. If it is unable to sync within a

few cycles, it then asserts the PRBS\_FAIL register. To stop the PRBS test, first turn the checker off on the receiver side, then turn the generator off on the transmitter side.

PRBS errors can be read from the VPRBS\_ERR register on the deserializer side. Any PRBS error causes the ERFB pin to go low in the deserializer by default (see VPRBS\_ERR\_OEN and VPRBS\_ERR\_FLAG register bits).

Note that the video channel shares link bandwidth. So, it is possible to have a bit error on the link that does not cause a video PRBS error.

### MIPI CSI-2 Output Raw PRBS Generator

The MAX96792A facilitates MIPI PHY characterization by generating PRBS output streams in the HS transmit mode directly from each C/D-PHY output lane. The available patterns are PRBS9, PRBS11, and PRBS18, and the resulting output data is a continuous stream not packetized by the CSI-2 controllers.

### Lane Deskew

The device's CSI-2 interface, configured to use D-PHY, supports interlane deskew by transmitting deskew patterns from the transmitter when the bit transmission rate is 1.5Gbps/lane and above. Deskew is optional for data rates lower than 1.5Gbps/lane. Deskew must be turned on using DESKEW\_INIT and DESKEW\_PER registers for each MIPI PHY. Refer to the GMSL2 user guide for details on configuring the lane deskew function.

### Minimum Blanking

The minimum horizontal blanking period needed by the CSI-2 serializers and deserializers is the maximum of either 40 pixels or  $300\text{ns} + 370\text{UI}$  (where UI is defined as the period of CSI-2 lane rate). For most cases, 40 pixels is the larger number. The minimum vertical sync width is one video line. The minimum vertical front porch is one video line. The recommended vertical back porch is one video line.

The minimum vertical back porch in pixel mode is the maximum of:

- 40 pixels
- $300\text{ns} + 370\text{UI}$

The minimum vertical back porch in tunneling mode is the maximum of:

- 40 pixels
- $200\text{ PCLK periods} + 233\text{ns}$ , where  $\text{PCLK} = \text{total MIPI data rate}/24$
- $300\text{ns} + 370\text{UI}$

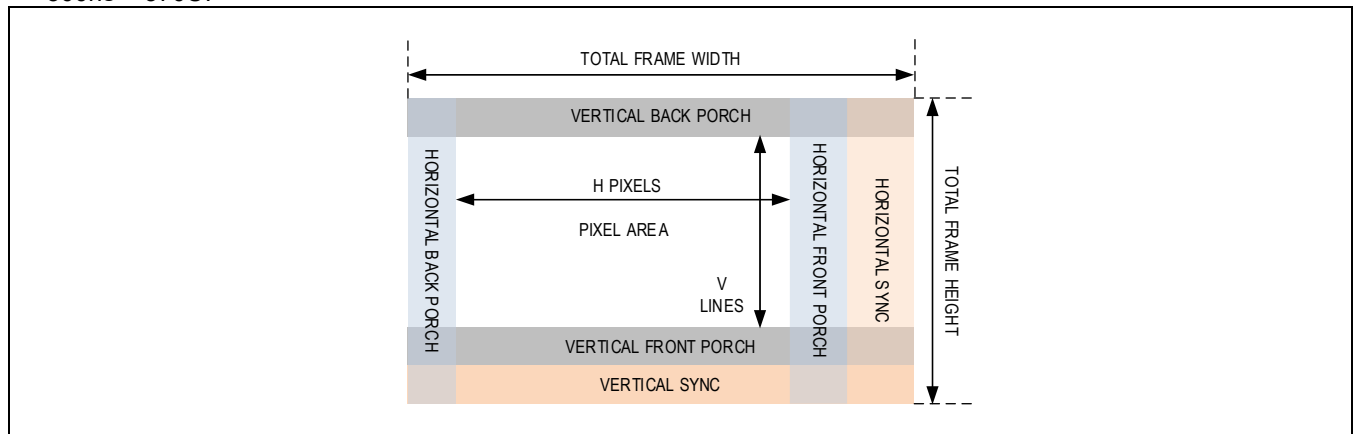

Figure 32. Video Timing

**MIPI End-to-End Packet Spacing**

When in Tunneling mode, timing requirements must be met to avoid a false line-CRC error flag. [Figure 33](#) shows that the end-to-end packet spacing (L1, L2, ... LN, LE, LS) must be a minimum of  $200 \times \text{PCLK} + 233\text{ns}$ , where PCLK is the total MIPI data rate/24. This limit is typically a concern for the line-end short packets, which follow the last long data packet of a frame. An alternate solution is to disable the line-CRC check and rely on the MIPI CSI-2 packet CRC, which is a valid verification of error-free data reception.

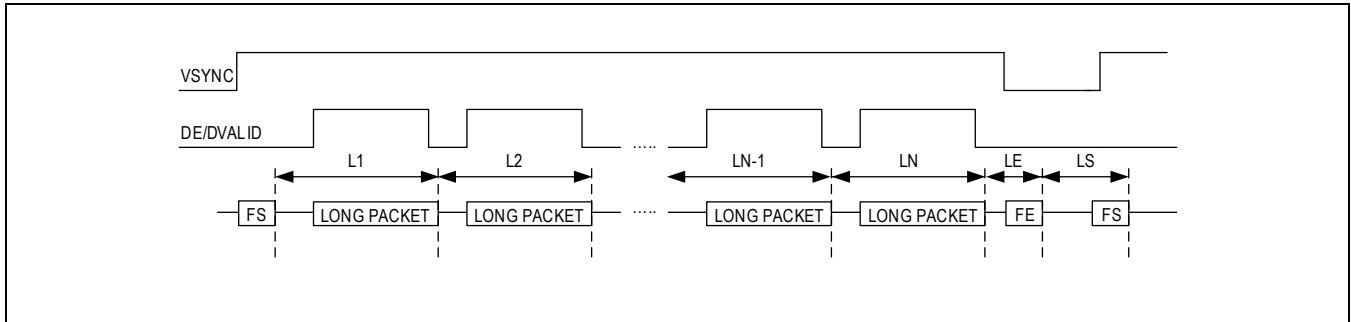

Figure 33. End-to-End Packet Spacing

**CFG Latch at Power-Up Pins**

At power-up or after reset, the voltages at the CFG pins (set by the voltage divider) are sampled. The sampled level is used to set the initial value of certain registers.

**Table 12. CFG0 Input Map**

| CFG0 INPUT VOLTAGE SPECIFICATION<br>(Notes a, b) (% of V <sub>DDIO</sub> ) |       |       | SUGGESTED RESISTOR VALUES<br>(1% TOLERANCE) (Note c) |        | MAPPED CONFIGURATION<br>(Note d, e) |                |
|--|-------|-------|--|--------|-------------------------------------|----------------|
| MIN  | TYP   | MAX   | R1 (Ω)   | R2 (Ω) | I <sup>2</sup> CSEL                 | DEVICE ADDRESS |
| 0.0%   | 0.0%  | 11.7% | OPEN   | 10k    | I <sup>2</sup> C                    | 0x50           |
| 16.9%  | 20.2% | 23.6% | 80.6k  | 20.5k  |                                     | 0x54           |
| 28.8%  | 31.2% | 35.5% | 68.1k  | 32.4k  |                                     | 0x98           |
| 40.7%  | 44.0% | 47.4% | 56.2k  | 44.2k  |                                     | 0xD4           |
| 52.6%  | 56.0% | 59.3% | 44.2k  | 56.2k  | UART                                | 0xD4           |
| 64.5%  | 67.9% | 71.2% | 32.4k  | 68.1k  |                                     | 0x98           |
| 76.4%  | 79.8% | 83.1% | 20.5k  | 80.6k  |                                     | 0x54           |
| 88.3%  | 100%  | 100%  | 10k  | OPEN   |                                     | 0x50           |

**Notes:**

- Resistor-divider tolerance, V<sub>DDIO</sub> supply ripple, and external loading must not cause the CFG0 input voltage to exceed the maximum or minimum limits.
- Other than the CFG0 input resistor-divider, any load on CFG0 must be  $\geq 25 \times (R1 + R2)$ .
- Each resistor in the voltage divider must be  $\leq 100\text{k}\Omega$ .
- I<sup>2</sup>CSEL: I<sup>2</sup>C or UART interface for SDA\_RX and SCL\_TX.
- When this address is selected, both serial inputs are automatically enabled. A single serial input can be programmed after power-up, if desired.

Table 13. CFG1 Input Map

| SPECIFICATION (Notes a, b)<br>(% of V <sub>DDIO</sub> ) |        |       | SUGGESTED<br>RESISTOR VALUES<br>(1% TOLERANCE)<br>(Note c) |        | MAPPED CONFIGURATION       |                        |                                  |                      |
|---|--------|-------|--|--------|----------------------------|------------------------|----------------------------------|----------------------|
| MIN   | TYP    | MAX   | R1 (Ω)   | R2 (Ω) | COAX OR<br>TWISTED<br>PAIR | DATA<br>RATE<br>[Gbps] | FORWARD<br>CHANNEL<br>MODULATION | TUNNEL/PIXEL<br>MODE |
| 0.0%  | 0.0%   | 11.7% | OPEN   | 10k    | STP                        | 6                      | NRZ                              | Tunnel               |
| 16.9%   | 20.2%  | 23.6% | 80.6k  | 20.5k  |                            | 12                     | PAM4                             |                      |
| 28.8%   | 32.1%  | 35.5% | 68.1k  | 32.4k  |                            | 3                      | NRZ                              | Pixel                |
| 40.7%   | 44.0%  | 47.4% | 56.2k  | 44.2k  |                            | 6                      |                                  |                      |
| 52.6%   | 56.0%  | 59.3% | 44.2k  | 56.2k  | COAX                       | 6                      | PAM4                             | Tunnel               |
| 64.5%   | 67.95% | 71.2% | 32.4k  | 68.1k  |                            | 12                     |                                  |                      |
| 76.4%   | 79.8%  | 83.1% | 20.5k  | 80.6k  |                            | 3                      | NRZ                              | Pixel                |
| 88.3%   | 100%   | 100%  | 10k  | OPEN   |                            | 6                      | NRZ                              |                      |

**Notes:**

- Resistor-divider tolerance, V<sub>DDIO</sub> supply ripple, and external loading must not cause the CFG1 input voltage to exceed the maximum or minimum limit.
- Other than the CFG1 input resistor-divider, any load on CFG1 must be  $\geq 25 \times (R1 + R2)$ .
- Each resistor in the voltage-divider must be  $\leq 100k\Omega$ .

**MFP Function Map and Slew Settings**

Side-channel functions, such as SPI and pass-through I2C/UART, are enabled by programming multifunction pins. Each MFP has several possible functions, but only one can be used at a time. Some functions require only a single MFP, but most are implemented across a group of MFPs. For example, LOCK is a single MFP, but SPI takes several MFPs. MFP functions are selected to suit each use case by programming the appropriate registers.

The [Pin Descriptions](#) table shows default and alternate functions for each MFP. [Table 14](#) also shows priority, left to right, with highest priority on the left. Disable a higher-priority function when enabling a lower-priority function, both by register writes.

Each MFP has a programmable slew setting that sets the transition time, as shown in [Table 15](#). Slew settings listed as I2C apply to pass-through I2C pins when pass-through I2C is enabled. The pin slew default in [Table 14](#) suits the MFP's normal application requirements. Except for I2C/UART and GPI\_ODO functions, where transition times are fixed, the transition time of each speed group can be changed from the default value through register programming.

Transition times depend on the transition-time setting and V<sub>DDIO</sub> supply voltage. See [Table 15](#) for typical transition times.

Table 14. MFP Pin Function Map

| PIN  | LATCH<br>ON<br>POWER-<br>UP | I <sup>2</sup> C/UART | SPI         | OTHER<br>FUNCTIONS             | GPIO  | POWER-UP<br>DEFAULT                          | PIN SLEW<br>DEFAULT<br>(BINARY) |
|------|-----------------------------|-----------------------|-------------|--------------------------------|-------|--|---------------------------------|
| MFP0 |                             | SDA1_RX1,<br>SDA2_RX2 | SCLK        | FSYNC_OUT, VS2,<br>DE2/DV2, MS | GPIO0 | GPI<br>(1MΩ to GND)                          | 10                              |
| MFP1 |                             | SCL1_TX1,<br>SCL2_TX2 |             | LOCK                           | GPIO1 | LOCK<br>(ODO, 40kΩ to<br>V <sub>DDIO</sub> ) | 11                              |
| MFP2 | CFG0                        |                       | BNE,<br>SS1 |                                | GPO2  | DISABLED<br>(Hi-Z)                           | 11                              |
| MFP3 | CFG1                        |                       | SS2         | VS1, DE1/DV1                   | GPO3  | DISABLED<br>(Hi-Z)                           | 11                              |

|       |  |                       |         |           |             |  |    |
|-------|--|-----------------------|---------|-----------|-------------|--|----|
| MFP4  |  |                       | RO(Alt) | ERRB      | GPIO4       | ERRB<br>(ODO, 40kΩ to V <sub>DDIO</sub> )      | 11 |
| MFP5  |  | SDA1_RX1,<br>SDA2_RX2 | MOSI    | LOCK(Alt) | GPIO5       | RX1<br>(40kΩ to V <sub>DDIO</sub> )            | 10 |
| MFP6  |  | SCL1_TX1,<br>SCL2_TX2 | MISO    |           | GPIO6       | TX1<br>(40kΩ to V <sub>DDIO</sub> )            | 10 |
| MFP7  |  |                       | RO      | LMN0      | GPI7        | GPI7<br>(1MΩ to GND)                           | NA |
| MFP8  |  |                       |         | LMN1      | GPI8        | GPI8<br>(1MΩ to GND)                           | NA |
| MFP9  |  |                       |         | LMN2      | GPI9        | GPI9<br>(1MΩ to GND)                           | NA |
| MFP10 |  |                       |         | LMN3      | GPI10       | GPI10<br>(1MΩ to GND)                          | NA |
| MFP11 |  | SDA_RX                |         |           | GPI11_ODO11 | SDA or RX<br>(ODO, 40kΩ to V <sub>DDIO</sub> ) | NA |
| MFP12 |  | SCL_TX                |         |           | GPI12_ODO12 | SCL or TX<br>(ODO, 40kΩ to V <sub>DDIO</sub> ) | NA |

All MFP pins are Hi-Z in power-down state.

All MFP IOs are latched in Sleep mode.

Hi-Z – 1MΩ pull-up/pull-down is disabled and input/output is disabled.

Latched – Value of input before Sleep mode entered remains latched in Sleep mode and after return to Power-up mode.

ODO = Open-drain output

**Table 15. Control- and Side-Channel Typical Rise and Fall Times**

| PIN SLEW         | RISE TIME (ns)<br>(20% to 80%), C <sub>L</sub> = 10pF |                          | FALL TIME (ns)<br>(80% to 20%), C <sub>L</sub> = 10pF |                          |
|------------------|---|--------------------------|---|--------------------------|
|                  | V <sub>DDIO</sub> = 1.8V                              | V <sub>DDIO</sub> = 3.3V | V <sub>DDIO</sub> = 1.8V                              | V <sub>DDIO</sub> = 3.3V |
| 00               | 1.0   | 0.6                      | 0.8   | 0.5                      |
| 01               | 2.1   | 1.1                      | 2.0   | 1.1                      |
| 10               | 4.0   | 2.3                      | 4.3   | 2.3                      |
| 11               | 9.0   | 5.0                      | 10.0  | 5.0                      |
| I <sup>2</sup> C | NA  | NA                       | 40  | 30                       |

**MFP Pin Equivalent Circuits**

In general, MFP pins can all be classified as either programmable high-speed GPIO or programmable I<sup>2</sup>C/ODO GPIOs. Equivalent circuit representations are shown in [Figure 34](#) and [Figure 35](#).

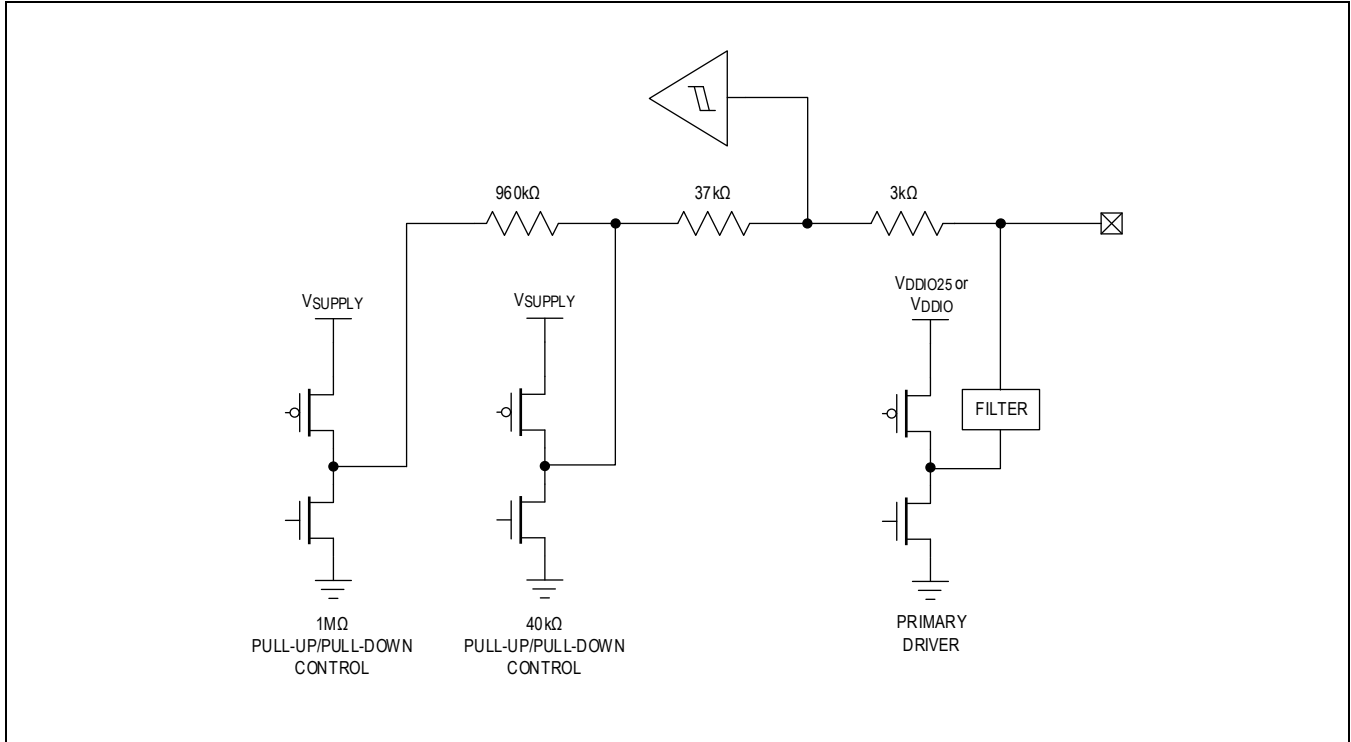

Figure 34. Standard High-Speed GPIO

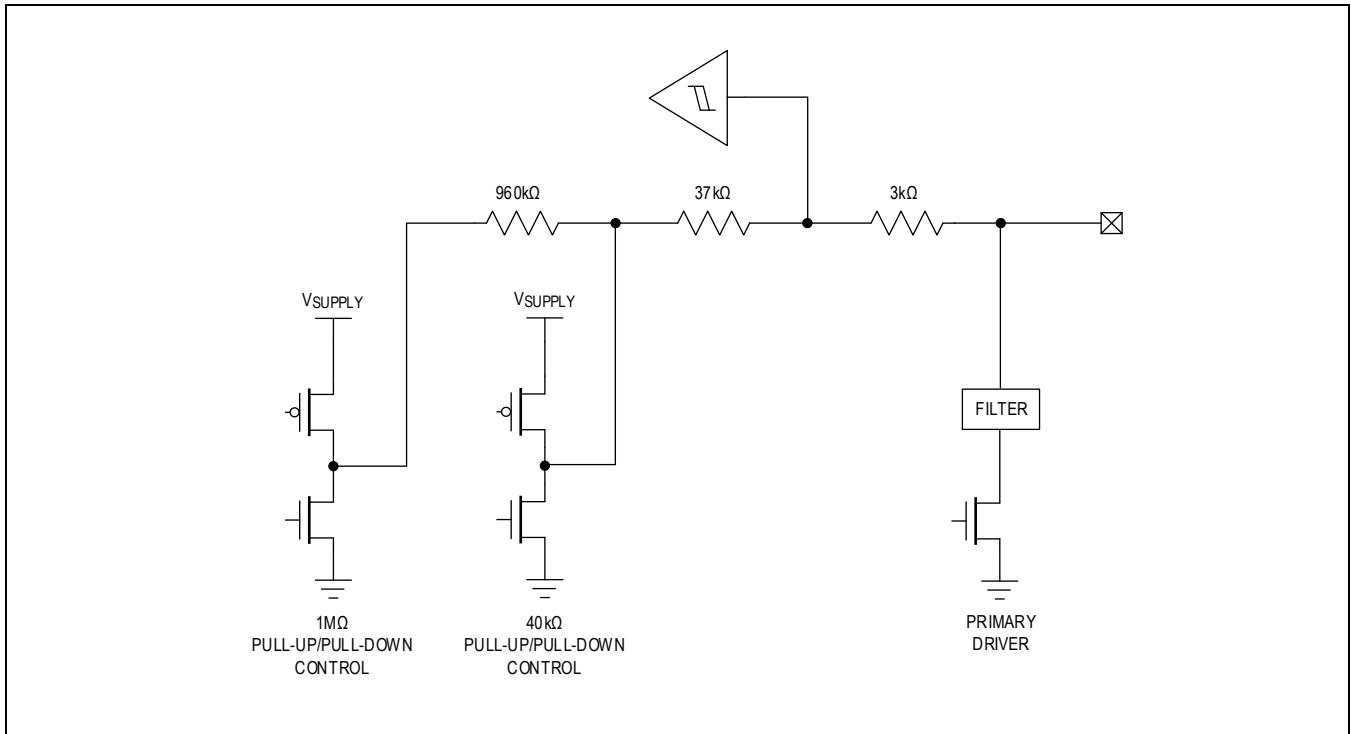

Figure 35. Standard I<sup>2</sup>C GPIO

## Power-Up and Link Start-Up

GMSL3 ICs are in power-down mode when the PWDNB pin is low or when any of the power supplies are down. Registers and configurations are set to default reset conditions.

The serializer and deserializer may power up in any order. After all power supplies are up and PWDNB is released, each starts its power-up sequence and performs these actions in sequence:

1. Latch at power-up CFG pin levels. Set the internal registers according to the selected configuration (selected by CFG0, CFG1).
2. The control channel (I<sup>2</sup>C or UART) is functional on local side. The device registers are writable and readable.
3. The link is established based on the following settings:
  - Single-link auto-selection mode (AUTO\_LINK = 1 and LINK\_CFG = 1 or 2): Automatically select the PHY to establish a GMSL3 link by periodically trying to handshake using PHY A and PHY B.
  - Single-link manual-selection mode (AUTO\_LINK = 1 and LINK\_CFG = 1 or 2): Set LINK\_EN\_B to 0 and keep LINK\_EN\_A at 1 to establish a link using PHY A. Set LINK\_EN\_A to 0 and keep LINK\_EN\_B at 1 to establish a link using PHY B.
  - Reverse-splitter mode. Link A and Link B (AUTO\_LINK = 1 and LINK\_CFG = 3) are selected: Mode aggregates data from both links within the deserializer to output on one or two MIPI output ports.
4. Each enabled PHY performs link calibration, equalizer adaptation, and data-channel locking. Both serializer devices will set their LOCK pin/bit high, and each of the LOCKED bits and LOCK pin on the serializer will be set high.
5. The control channel is available from the remote side.

The entire link-up process, from the time that the last part's PWDNB input is brought high, takes typically 65ms for any channels that meet the GMSL3 channel specifications.

After the devices are linked, they can be configured. This can be done locally or over the control-channel, by a microcontroller on either the serializer or deserializer side.

## Device Reset

There are three general reset options available through register writes:

- RESET\_ALL resets all blocks including all registers, digital blocks, and analog blocks. This process is similar to driving the PWDNB pin low and then high. Note: If Sleep mode is used, do not use RESET\_ALL, as it returns the device to Sleep mode.
- Setting RESET\_LINK resets all GMSL PHY-related digital logic and data pipelines. After this bit is set, all control registers are still accessible through the local control-channel and their values are preserved. The link and data pipelines are held in RESET until RESET\_LINK is cleared.
- RESET\_ONESHOT resets all GMSL PHY-related digital logic and data pipelines, and then automatically clears itself. This is similar to setting and clearing RESET\_LINK.

Program the registers that affect GMSL link operation (i.e., TX\_RATE, RX\_RATE, CXTP\_A/B, AUTO\_LINK, LINK\_CFG, GMSL2) first, followed by RESET\_ONESHOT, or set these registers when RESET\_LINK = 1, and then set RESET\_LINK = 0. Setting LINK\_CFG = 3 is a special case that requires writing LINK\_CFG = 3 and RESET\_ONESHOT = 1 in the same register byte write.

## Link and Video Lock

### Link Lock

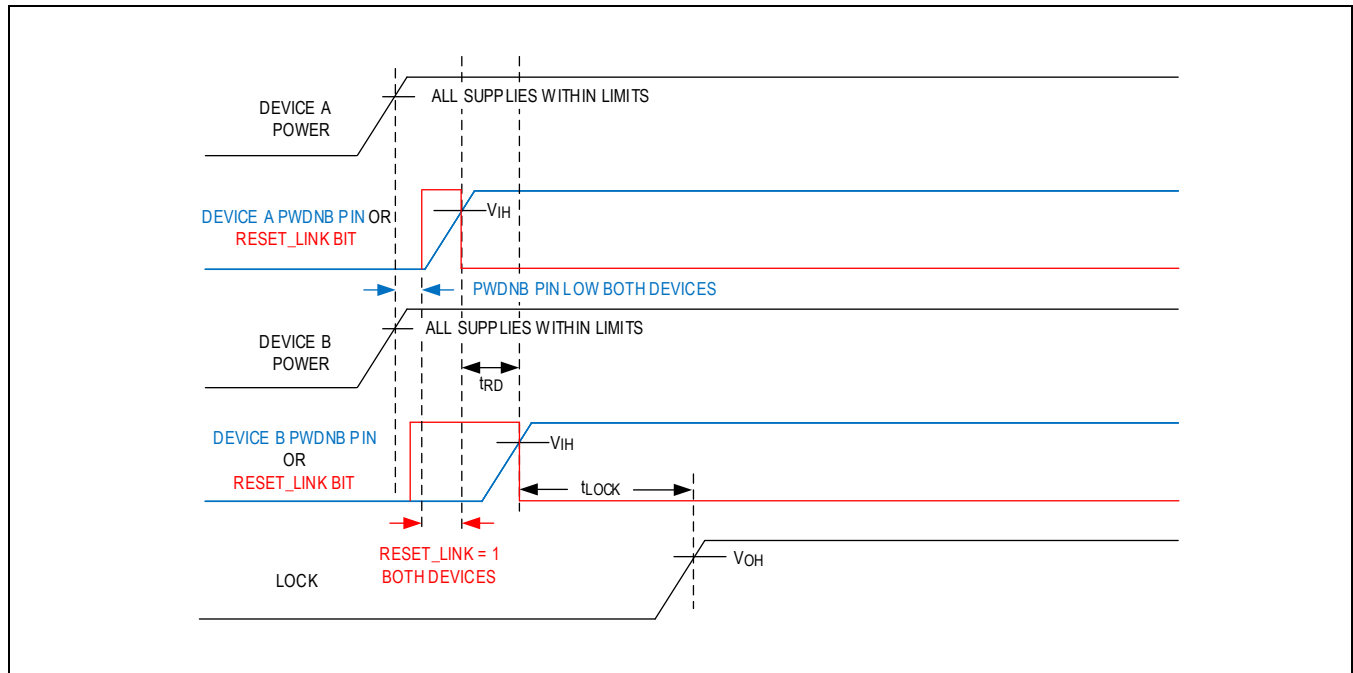

Figure 36. GMSL3/2 Lock Time

Figure 36 illustrates the sequence that is used to characterize GMSL3/2 link lock time. Device A is the first device (serializer or deserializer) to power-up or resume operation from a RESET\_LINK state. Device B is the device (deserializer or serializer) at the other end of the GMSL link.

Link lock indicates that the data receive paths are locked (forward channel in the deserializer, reverse channel in the serializer). Video and control channel functions (I<sup>2</sup>C/UART, SPI, GPIO, audio) can be used immediately after link lock is asserted.

The device will establish single link GMSL3/2 connectivity and link lock automatically following power-up. This is an indication that the cable is plugged in, and the system is up and running. Lock is obtained with no interaction between the  $\mu$ C and GMSL devices. Both serializers and deserializers have an open-drain LOCK output pin and a related status register.

Dual-link and splitter configurations require additional user programming. For guidance on enabling these configurations and optimizing the lock time, contact the factory.

The GMSL3/2 link uses the crystal as the reference clock for GMSL3/2 links, so a valid video input (PCLK) is not needed for the GMSL3/2 link to lock.

#### Notes:

- The lock sequence is initiated by the release of the PWDNB pin or the RESET\_LINK bit in either the serializer or the deserializer.
- The lock time is measured from the later of the PWDNB or the RESET\_LINK release on either the serializer or the deserializer to LOCK being asserted.
- The PWDNB/RESET\_LINK states on the two sides of the link must have overlap when both the devices are in PWDNB/RESET\_LINK mode prior to the lock process starting.
- If RESET\_LINK is used to initiate the lock, the PWDNB is assumed to be high after power-up (normal operation).
- If PWDNB is used to initiate the lock, the RESET\_LINK is assumed to be low after power-up (normal operation).
- Device A is the first device (serializer or deserializer) to be powered up. Device B is the device (deserializer or serializer) at the other end of the GMSL link.

- To achieve the specified lock time, time delay  $t_{RD}$  (delay between release of the PWDNB/RESET\_LINK on the two devices), must be less than 90ms. If this timing cannot be guaranteed, contact the factory for guidance.
- Lock time and maximum allowed  $t_{RD}$  vary between different families of GMSL devices. They depend on the characteristics of both the serializer and deserializer. The typical lock time of a specific link can be best estimated as the longer of the lock times specified in each device data sheet. Similarly, the maximum permission  $t_{RD}$  for a specific link can be estimated as the smaller of the values specified in each device data sheet. For further guidance, contact the factory.
- If there is an instantaneous interruption to link lock, a period of 100ms following loss of lock should be provided to enable the link to automatically recover prior to any ECU initiated resets being issued. This will minimize any disruptions caused by a transient loss in connectivity.

### Video Lock

Video lock bit indicates the deserializer is receiving valid video data. After the GMSL3 link is locked, the deserializer video output PLL starts its locking sequence. The deserializer normally starts outputting video data several milliseconds after it asserts line lock, provided it is receiving video packets from the serializer. The video lock status is typically read from a register. However, the deserializer LOCK pin behavior can be changed by a register setting so that the LOCK pin is asserted only when the deserializer is outputting video.

### Error and Fault-Condition Monitoring

The MAX96792A deserializer has an open-drain, multipurpose error-reporting and interrupt status output. The active-low ERRB pin is driven by the logical OR of a wide variety of error and event status indicators. The ability of each error condition to drive ERRB is maskable by register settings. Each error and event that can drive ERRB has a status flag within a sub-block of registers, so the reason for assertion of ERRB can be determined by reading the register status. Errors can be automatically forwarded across the link from a serializer so that certain serializer errors, such as CSI-2 input-CRC, can be automatically flagged by the MAX96792A's ERRB output.

The following are key points for reference:

- ERRB is enabled by default.
- ERRB has a 40k pull-up to  $V_{DDIO}$  by default.
- If the device powers down ( $PWDNB = 0$  or undervoltage), ERRB transitions to an high-Z state.
- For ERRB to go low in the power-down state, an external pull-down to ground is needed.

### Clocking

The MAX96792A requires an external reference clock source to generate internal device clocks. The external reference can be a 25MHz crystal or oscillator with  $\pm 200$ ppm accuracy.

### Spread-Spectrum Clocking

Spread-spectrum clocking is used to mitigate electromagnetic interference emitted from the devices. Narrow frequency peaks of the clock signal are reduced by modulating the internal 6GHz clock at a rate of 25kHz with a saw-tooth profile that extends the frequency by  $\pm 1250$ ppm.

### Power Supplies

There is no required sequence to bring up the device power supplies. An on-chip power management block manages the power domains during power-up.

The MAX96792A provides flexible power supply configurations.

The 1V core supply can be provided directly or through an internal low dropout (LDO) regulator. To minimize power dissipation, connect  $1.0V \pm 5\%$  to  $V_{DD}$ . If  $V_{DD} < 1.1V$  and  $CAP\_V_{DD} < 1.05V$ , the regulator is automatically disabled at power-up and low-resistance switches connect  $V_{DD}$  to the internal supply rails. When using the internal LDO, connect  $1.2V \pm 5\%$  to  $V_{DD}$ , and following power-up, write  $REG\_ENABLE = 1$ , then write  $REG\_MNL = 1$  as part of the device initialization to enable the internal LDO.

The  $V_{DDIO}$  supply for the GPIO pins can be 1.8V to 3.3V for flexibility in accommodating devices interfacing to the part. The allowable supply voltage range is 1.7V (1.8V -5%) to 3.6V (3.3V +9%).

$V_{DD18}$  is the analog supply. Connect  $1.8V \pm 5\%$ .

$V_{TERM}$  is the D-PHY/C-PHY driver and termination supply. Connect  $1.2V \pm 5\%$ .

Power supply ramp-time recommendation:  $20\mu\text{s} < \text{ramp time} < 2\text{ms}$ . Power supply ramps must be monotonic. Once the supply voltage reaches the minimum supply voltage limit, it should not be allowed to drop below the specification.

Proper power supply bypassing of all supplies is essential for high-frequency circuit stability. See [Table 3](#). See [Table 2](#) for power supply tolerances and noise requirements. Contact the factory for guidance on sharing supplies and optimizing supply decoupling.

The MAX96792A provides extensive power supply diagnostics capabilities. Undervoltage detection is included for all power supplies. Moderate undervoltage conditions on the  $V_{DD18}$  and  $V_{DDIO}$  supply voltages can be indicated using either the ERRB pin or by reading the register field associated with the power supply undervoltage flag. The power manager detects an undervoltage condition on the  $V_{DD}$  supply, which can corrupt the register configuration, and cause a reset. Similarly, a severe undervoltage condition on  $V_{DD18}$  or  $V_{DDIO}$  also results in a reset. When a reset occurs, device configuration reverts to the power-up default state when the supplies have recovered, and the host device must initiate the power-on initialization procedure to return the device to full operation.

Overvoltage detection is also provided for all supply voltages. As in the case of undervoltage events, the ERRB pin reports an overvoltage situation in addition to a dedicated internal interrupt flag. No further action is taken by the power manager during an overvoltage situation, and the device continues to operate, although it may sustain damage depending on the duration and magnitude of the overvoltage event.

When relying on the ERRB pin to convey the occurrence of an undervoltage event, connect an external  $1\text{M}\Omega$  resistor between the ERRB pin and ground, because ERRB is not a power-up default MFP function. As a result, following a reset triggered by an undervoltage event, the ERRB MFP pin reverts to high impedance as opposed to ERRB. During an error state, the host device expects ERRB to drive logic low, and the presence of the aforementioned resistor enables the appropriate logic level to be maintained following the reset, alerting the host device that attention is required.

### Power Standby and Sleep Mode

A power manager block is present in all GMSL3 products. Its primary function is to monitor supply voltages, and control power-down (standby) and sleep modes.

There are two ways to enter low-power mode while all power supplies are active: asserting the PWDNB pin or invoking the sleep state. Both states offer very-low-power supply currents.

Asserting the PWDNB pin (active-low) places the device in standby power mode, and resets the digital registers and configurations to their default power-up conditions. Any supply dropping below its internal threshold settings also places the device in power-down mode.

The sleep state preserves critical register settings and configurations. Retained registers are detailed in the Register Table. The device can be put into the sleep state through an I<sup>2</sup>C/UART command. The resume state restores the device to the presleep condition without the need for additional register writes. Resume is invoked by an I<sup>2</sup>C command or a low-frequency clock beacon transmitted from the main device over the GMSL3 link. Note that GPIO levels set by received values from the other side of the link are not retained when entering Sleep mode. Disable GPIO receive and set GPIO values to known levels before entering Sleep mode.

### PCB Layout Guidelines for GMSL

Proper circuit board design techniques are required for optimal GMSL link performance. This includes having at least a four-layer board to provide a proper ground plane reference, adequate thermal impedance, DC supply pin bypassing, power-over-coax or line-fault design, and high-speed GMSL trace impedance matching.

#### Ground Plane

A consistent ground plane, generally the second layer, is recommended to provide isolation from the high-speed GMSL traces, and other traces and components that can couple noise onto the GMSL signals. This also simplifies the design of impedance-matched transmission lines. The ground plane is also key to providing a low thermal impedance to the device's exposed paddle.

### High-Speed GMSL Traces

Proper transmission-line design techniques are needed to achieve optimal GMSL link performance. The characteristic impedance must be closely matched to the desired impedance (50Ω single-ended or 100Ω differential). Any mismatch increases insertion-loss and causes reflections (degrade return-loss). The suggested layout practices are:

- Use only 100Ω differential or 50Ω single-ended traces.
- Minimize length of high-speed traces.
- Minimize pad stubs by placing component pads directly on the signal trace.
- Use ground cutouts under pads as required, (1.3x area of pad).
- Follow vendor layout recommendations for components, including connectors.
- Avoid sharp bends on high-speed traces.
- Place AC-coupling capacitors within 500mils of the SIOx pins.
- Place the GMSL device as close to the serial-link connector as possible to minimize insertion loss.
- Stitch ground layers together with vias near high-speed traces.

### Power-Over-Coax (PoC) Layout

When used, the PoC circuit must provide a low DC-series resistance to the power supply while minimizing the loading of the GMSL forward and reverse signals. The PoC circuit wants to behave as a Bias-Tee, and this requires proper layout techniques for optimal GMSL link performance, including:

- Place the smallest valued inductor (highest SRF) on the GMSL signal trace.
- Place the next smallest valued inductor after the smallest.
- Use ground cutouts as needed under first two inductors and resistors. See [Figure 37](#).
- Place the PoC as close to the device as possible, within 1/2 UI (most important for the deserializer).

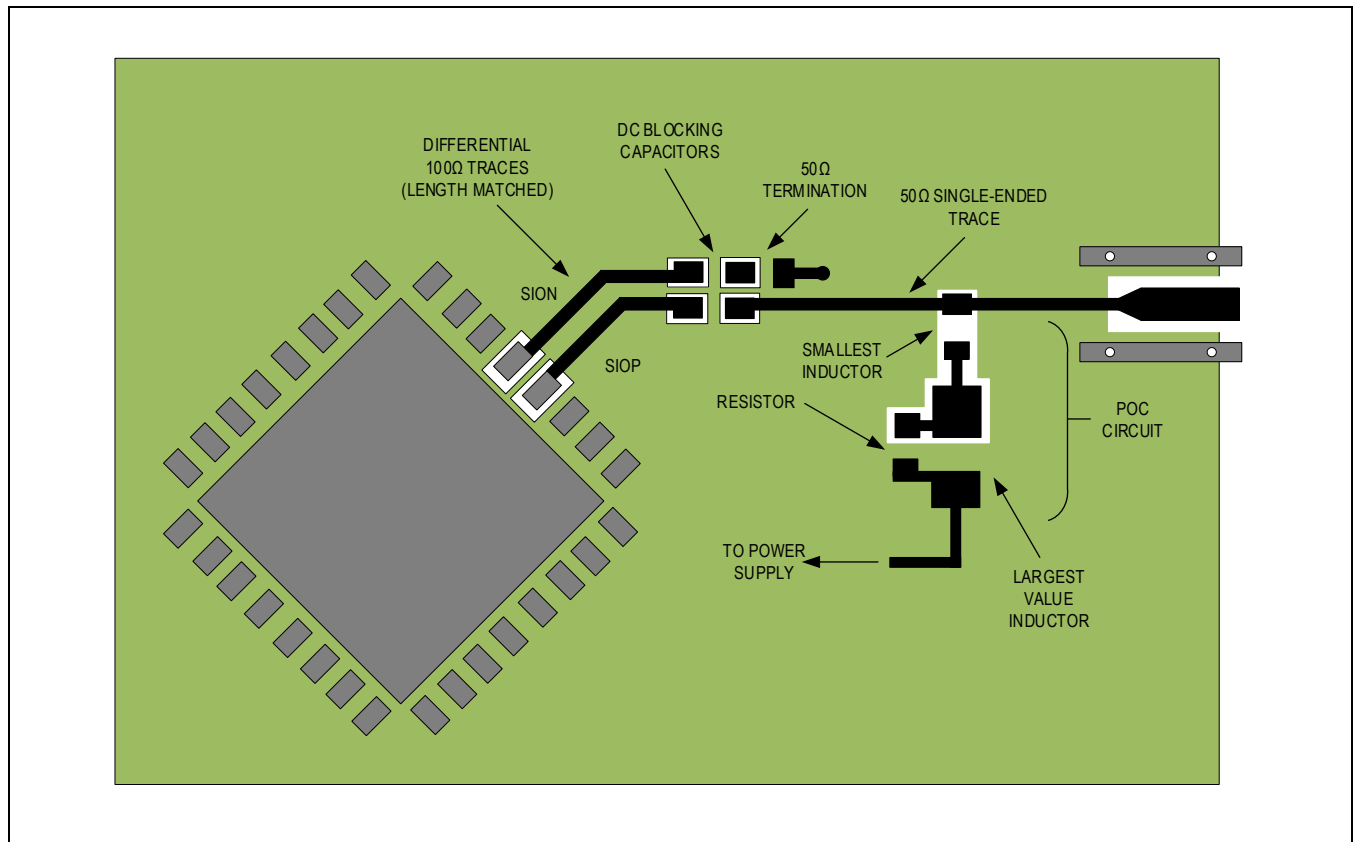

Figure 37. Coax PoC Layout Example

### Shielded Twisted-Pair (STP) Layout

STP designs require the differential traces to closely maintain a differential impedance of  $100\Omega$ . Use ground cutouts under AC-coupling capacitors and line-fault resistors. See [Figure 38](#).

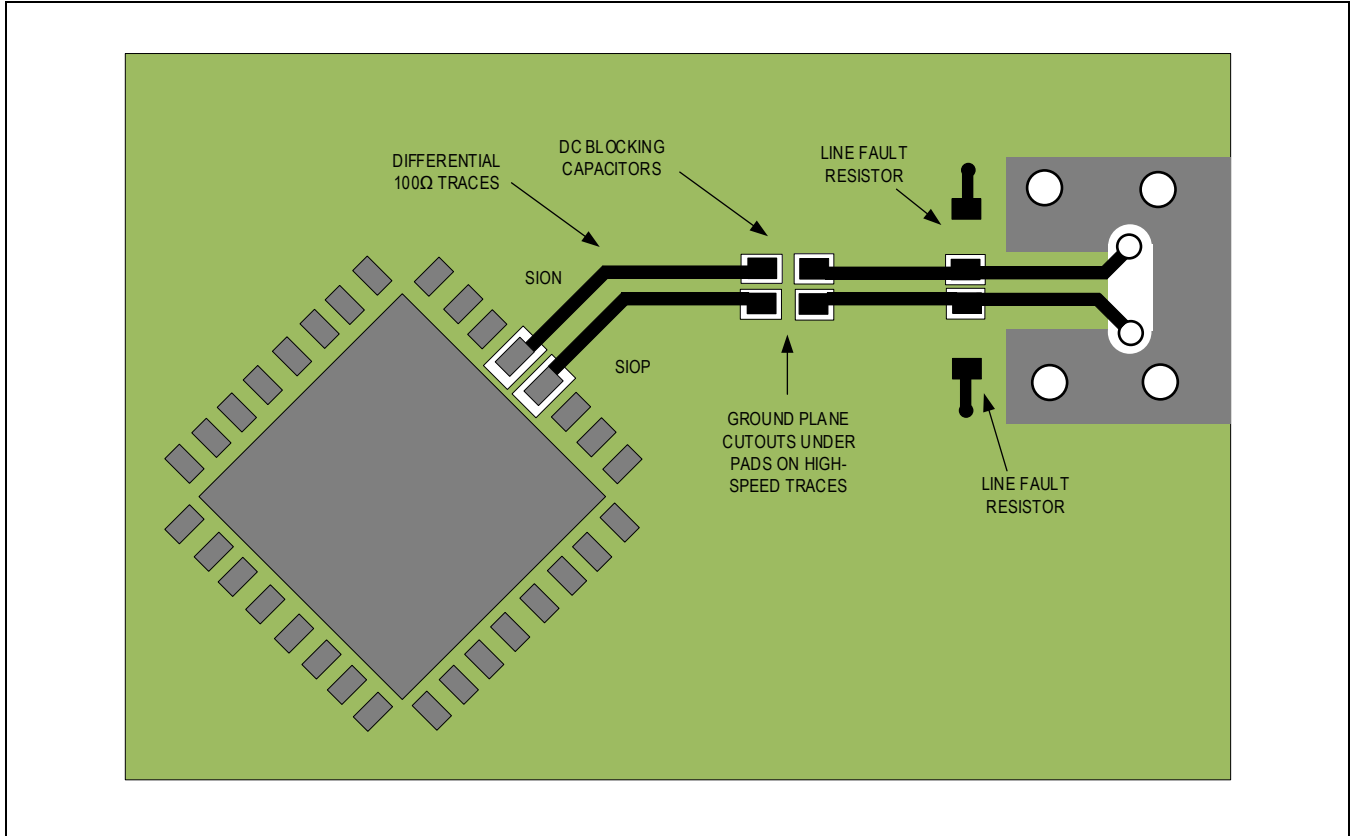

Figure 38. STP Layout Example

### Thermal Management

Power consumption of GMSL3 devices varies based on use case. Take care to provide sufficient heat dissipation with proper board and cooling design techniques. The package exposed pad must be connected to the PCB ground plane by an array of vias. This approach simultaneously provides the lowest electrical and thermal impedances.

System thermal management must keep the operating junction temperature below  $+125^{\circ}\text{C}$  to avoid impacting device reliability.

Refer to Tutorial 4083 ([www.analog.com/thermal-tutorial](http://www.analog.com/thermal-tutorial)) for further guidance.

## Applications Information

### Software Programming Model

Analog Devices' automotive serializers and deserializers follow a general software programming model. Except for features that require in-operation control-channel accesses such as ASIL safety measures and interrupt handling, use the following programming model:

1. Set the impacted functional blocks to disabled or reset mode. Place the part in IDLE state to stop all side-channel and video traffic, followed by a register write (`RESET_LINK = 1`) to stop the GMSL link.
2. Fully configure the settings for each feature before it is enabled.
3. Establish the link by setting `RESET_LINK = 0` and wait for the link to lock.
4. Start video and side-channel traffic.

If changing the configuration of a feature during the operation of other features, disable the reconfigured feature, change its settings, and re-enable it.

### Programming Notes

#### Mandatory Register Programming

Make the following register writes to ensure proper operation. Without these writes, the operation of the device, as specified in the data sheet, cannot be guaranteed.

If the part is used with  $V_{DD} = 1.2V$ , execute the following register writes during initialization:

Set bit [2] = '1' in register 0x10

Set bit [4] = '1' in register 0x12

#### Primary I<sup>2</sup>C/UART Tunnel

By default, the primary I<sup>2</sup>C/UART control channel is also sent to the remote-side device and any peripheral connections. This allows control of the GMSL devices from either end of the link. For multimain configurations, with microcontrollers connected to both the serializer and deserializer, disable the remote control-channel through register settings to prevent bus contention.

#### Control-Channel Programming

At power-up, GMSL3 device registers are accessed and configured only through the primary I<sup>2</sup>C/UART interface. The pass-through I<sup>2</sup>C/UART interfaces can be enabled for access to the device registers through register control.

#### Conventional I<sup>2</sup>C/UART Control-Channel Programming

##### Host-to-Peripheral Primary I<sup>2</sup>C and Pass-Through I<sup>2</sup>C Communication

When communicating between a host and peripheral, main and pass-through I<sup>2</sup>C operations are the same. A passthrough I<sup>2</sup>C across the GMSL3 link connects the host's I<sup>2</sup>C main to the peripheral's I<sup>2</sup>C subordinate. This logically connects separated I<sup>2</sup>C buses, enabling I<sup>2</sup>C transactions across the serial link to occur (with some delay) as if performed on the same physical I<sup>2</sup>C bus. The GMSL3 serializer and deserializer are intermediary devices; the host I<sup>2</sup>C main connects to a GMSL2 device I<sup>2</sup>C subordinate, and the peripheral I<sup>2</sup>C subordinate connects to a GMSL3 device I<sup>2</sup>C main. For example, when the host I<sup>2</sup>C main transacts on one side of the link (local-side), data is forwarded to the other side (remote-side) by the I<sup>2</sup>C subordinate of the local-side GMSL2 device. Data is then received by the I<sup>2</sup>C main of the remote-side GMSL2 device, which in turn generates the same I<sup>2</sup>C transaction with the peripheral subordinate I<sup>2</sup>C. The remote-side GMSL3 device sends back any I<sup>2</sup>C data expected by the local-side. Note, this device does not support passthrough I<sup>2</sup>C/UART channels to access the primary I<sup>2</sup>C/UART control-channel on the remote side.

The I<sup>2</sup>C interface uses clock stretching (holding SCL low) to account for timing differences between the main and subordinate, and to allow time for data to be forwarded and received across the serial link. All local-side I<sup>2</sup>C devices must support clock stretching by the GMSL3 device. Remote-side I<sup>2</sup>C devices are not required to support clock stretching.

SDA and SCL lines operate as both an input and open-drain output. Pull-up resistors are required on SDA and SCL.

Each transmission consists of a START condition sent by a main, followed by the device's 7-bit subordinate address plus a R/W bit, register address bytes, one or more data bytes, and finally a STOP condition.

Register addresses are 16 bits wide. Single or multiple data bytes can be written or read (by address auto-increments).

**I<sup>2</sup>C Write Packet Format**

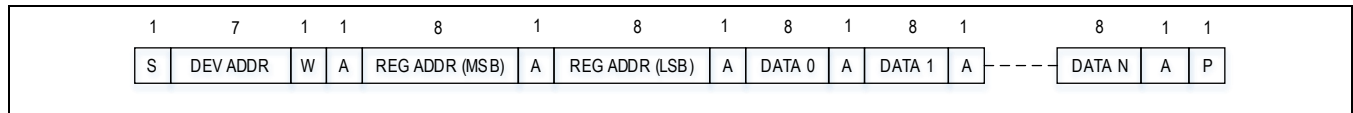

Figure 39. I<sup>2</sup>C Write Packet Format

**I<sup>2</sup>C Read Packet Format**

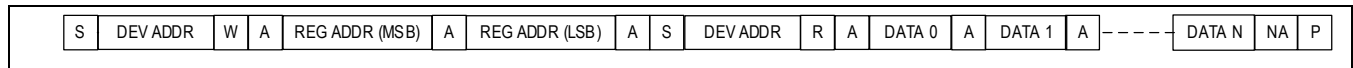

Figure 40. I<sup>2</sup>C Read Packet Format

**Primary I<sup>2</sup>C Host-to-GMSL2 Device Communication**

The primary I<sup>2</sup>C main has access to GMSL3 serializer and deserializer registers. The primary can program GMSL3 device registers to change the pass-through I<sup>2</sup>C/UART interface as I<sup>2</sup>C or UART.

**Main UART**

When the main I<sup>2</sup>C/UART is configured as a UART, there are two operating modes: Base and Bypass.

**UART Base Mode**

In Base mode, the microcontroller communicates with the serializer and deserializer, where registers in these and peripheral devices can be accessed. Base mode is typically enabled by default at power-up. In Base mode, the  $\mu$ C is the host and can access the registers of both the serializer and deserializer from either side of the link using the GMSL3 UART-packet protocol. The  $\mu$ C can also program the peripherals on the remote side by sending the UART packets to the serializer or deserializer. The  $\mu$ C communicates with a UART peripheral in Base mode (through INTTYPE register settings). The device addresses of the serializer and deserializer in this mode are programmable. In Base mode, the serializer, deserializer, and peripheral registers can be written and read using the half-duplex GMSL3 UART protocol. Base mode is enabled by default at power-up.

Figure 41 shows the UART protocol for writing and reading in Base mode.

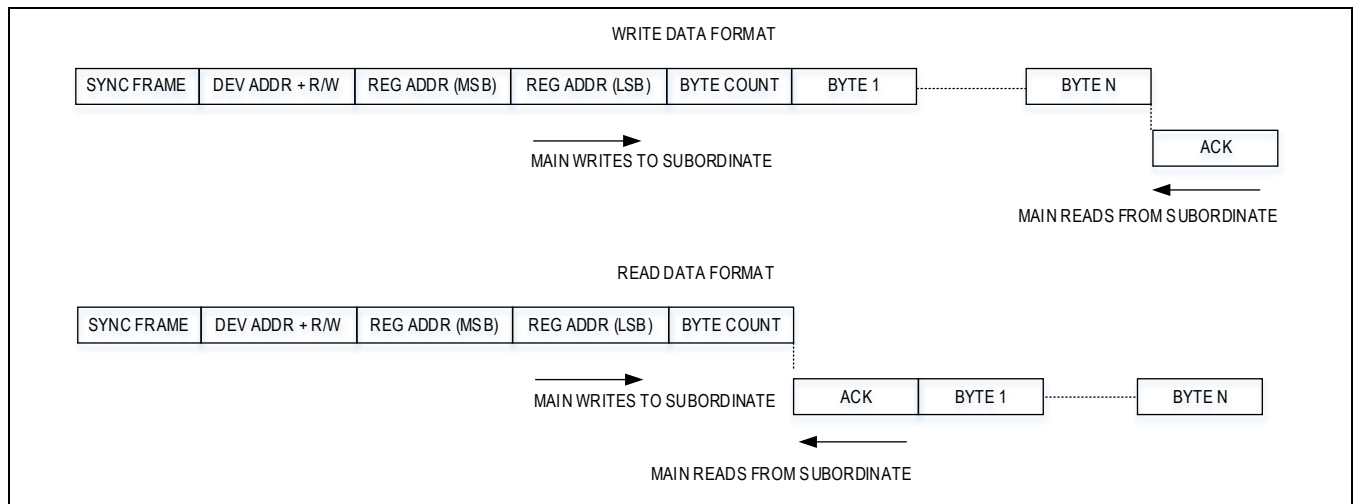

Figure 41. UART Protocol for Base Mode

**UART Bypass Mode**

In Bypass mode, the serializer/deserializer ignore UART commands from the  $\mu$ C, and the  $\mu$ C communicates only with the peripherals using its own defined UART protocol. The  $\mu$ C cannot access the serializer/deserializer’s registers in this mode. The UART transactions are simply sent over the GMSL3 link. Ignoring UART transactions prevents inadvertent misprogramming of serializer and deserializer registers. The device addresses of the serializer and deserializer in this mode are not programmable.

**Switching Between UART Base and Bypass Modes**

There are two ways to switch between Base and Bypass modes: programming the BYPASS\_TO register and using the device MS pin.

When setting Bypass mode through register, BYPASS\_TO is programmed to have a timeout (2ms, 8ms, or 32ms). Bypass mode is active only as long as there is UART activity. When there is no UART activity for the selected timeout, both devices exit Bypass mode, and the bit is automatically cleared.

When in UART Bypass mode, random data may be output if link lock is lost. This issue can be avoided by not enabling UART Bypass mode until all initial device programming is completed.

When set by the MS pin, a high-level puts the device into Bypass mode, and a low-level puts the device in Base mode. MS is set on the fly and is not latched on power-up.

**UART Frame Format**

Regular UART frames with an even-parity bit are used to carry 1 byte of data each. A frame consists of a low-start bit followed by 8 data bits, a parity bit, and a high-stop bit. The parity bit is high if the number of 1s in the 8-bit data is odd; otherwise, it is low. There must be at least 1 high-stop bit. If the next frame is in the same packet, there can be no more than 4 high bits from the end of the stop bit to the beginning of the next start bit. Note that for a parity-bit error, the packet, starting from the frame with the error, is discarded. The start of each frame is always a high-to-low transition (i.e., stop-bit is high and start-bit is low). The phaser calibrates the length of 1 UART bit in terms of the internal oscillator clock using the synchronization frame (i.e., the first frame of a UART packet transmission). In Bypass mode, the parity bit is enabled by default, but the frames are not checked for parity errors. Either even or odd parity can be used. The parity bit is passed with UART data transmissions; the recipient of the data must perform error checking. The parity bit can optionally be disabled before entering Bypass mode. Note that the bit rate in Bypass mode must be the same bit rate last used in Base mode. See [Figure 42](#).

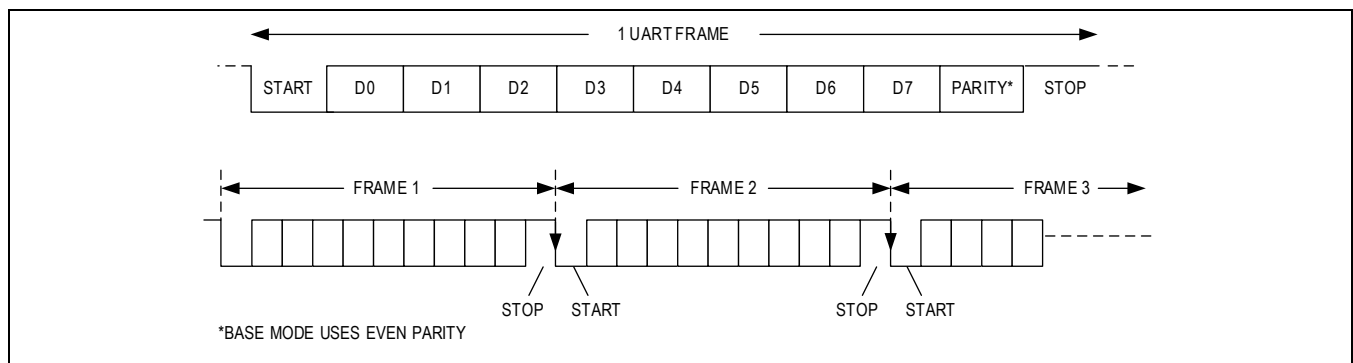

Figure 42. UART Data Format for Base Mode

**Synchronization Frame**

The serializer/deserializer must calibrate internal bit-length counters with the UART bit rate for proper recovery of UART frames. The μC sends a synchronization frame (a regular UART frame with the value 0x79) as the first frame of each data packet. The synchronization frame allows the addressed device to calibrate the bit length in terms of the device’s internal 150 MHz clock. A synchronization frame must be properly detected before the subsequent frames of the packet can be correctly received. When the line stays high for at least 32 bits, the packet boundary is reset and the framer begins waiting for the next synchronization frame. See [Figure 43](#).

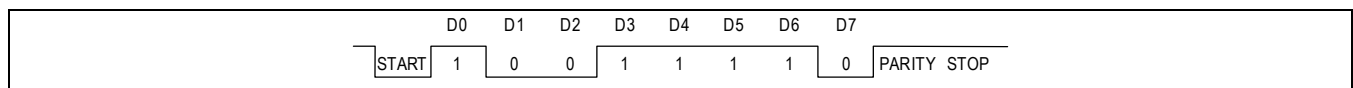

Figure 43. UART Synchronization Frame

### Acknowledge Frame

When a packet is successfully received, the addressed device responds with an acknowledge frame to inform the  $\mu\text{C}$  that no errors are detected in the transmitted packet. The acknowledge frame is sent after the last bit of a valid packet is received. The acknowledge frame is a regular UART frame (value 0xC3). Data written to the serializer/deserializer registers do not take effect until after the acknowledge byte is sent. See [Figure 44](#).

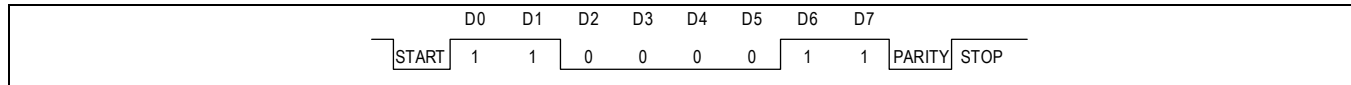

Figure 44. UART Acknowledge Frame

### Write Packet

Write packets consist of a 5-byte packet header followed by 1 or more data bytes. A packet is recognized as a write packet when the LSB of the device address frame is 0. The addressed device responds with an Acknowledge frame if no errors are detected while receiving a valid write packet. Byte Count indicates the number of data bytes to be written; this number cannot be zero. See [Figure 45](#).

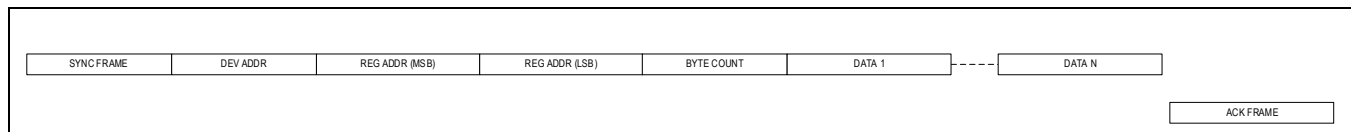

Figure 45. UART Write Packet Format

### Read Packet

Read packets consist of 5 bytes. The LSB of the device address frame is 1 for read packets. If no errors are detected while receiving a valid read packet, the addressed device responds with an Acknowledge frame followed by 1 or more data bytes. Byte Count indicates the number of data bytes to be read; this number cannot be zero. See [Figure 46](#).

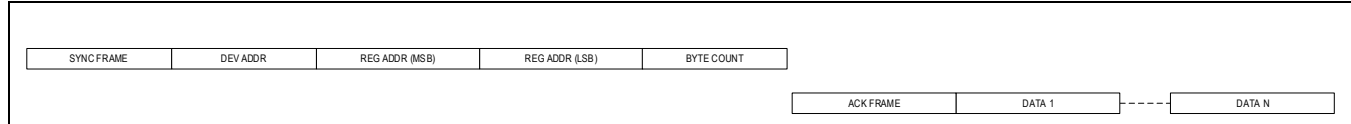

Figure 46. UART Read Packet Format

### I<sup>2</sup>C/UART Control-Channel Programming with Optional CRC and Message Counter

The MAX96792A provides additional functional safety by adding an optional CRC to I<sup>2</sup>C/UART read/write transactions and a separate Message Counter for read and write packets. These features are disabled by default at power-up, but can be enabled by register settings. The CRC and Message Counter can be used together or individually. The CRC and Message Counter features only apply to device register read/write transactions and are not supported for pass-through traffic. The CRC and/or Message Counter can be enabled in the serializer, deserializer, or both.

#### I<sup>2</sup>C/UART CRC and Message Counter Options

At power-up, the I<sup>2</sup>C/UART CRC and Message Counter features are disabled by default in the MAX96792A. Both features can be enabled or disabled through register control.

#### I<sup>2</sup>C Writes with CRC

To provide additional functional safety for ADAS applications, the MAX96792A supports the addition of a CRC to I<sup>2</sup>C transactions. When enabled, the main  $\mu\text{C}$  must compute and send a CRC byte after each data byte. See [Figure 47](#). For each single-byte or multibyte write, the serializer first clears the CRC engine. The first CRC includes the device address byte, register address bytes, message counter bytes, and first data byte. For all following data bytes, the CRC engine is reset and the CRC byte covers the additional data byte. See [Figure 48](#) and [Figure 49](#). The serializer receives the data byte, calculates the CRC using an identical CRC engine, and verifies a match before accepting the data byte. If the CRCs do not match, a write is not accepted, a NACK is transmitted, and the error counter is triggered.

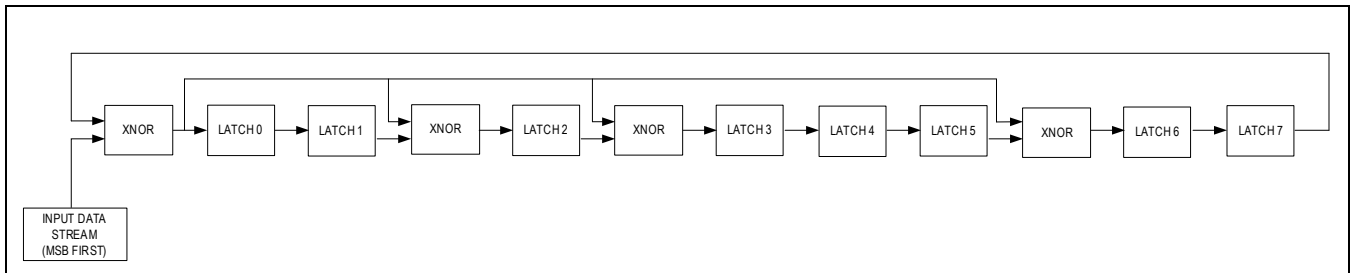

Figure 47. I<sup>2</sup>C CRC Engine

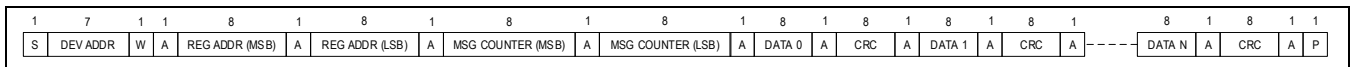

Figure 48. I<sup>2</sup>C Multiple-Byte Write with CRC

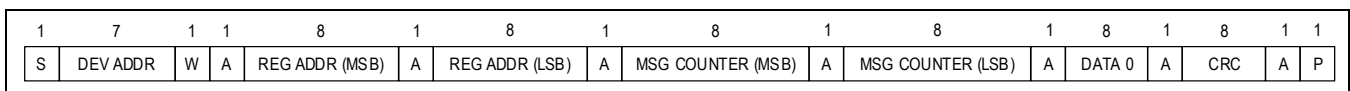

Figure 49. I<sup>2</sup>C Single-Byte Write with CRC

**I<sup>2</sup>C Reads with CRC**

For I<sup>2</sup>C reads of the MAX96792A's registers, the device's CRC engine clears and then uses the outgoing device address byte, register address bytes, message counter bytes, and first data byte to calculate the CRC byte. This is added to the data stream directly after the corresponding data byte. The CRC engine is subsequently cleared again for all other data bytes. See [Figure 50](#) and [Figure 51](#). When the μC receives the I<sup>2</sup>C read data, either through the MAX96792A or directly from the device on the other side of the link, the μC's CRC engine should calculate a CRC byte for each data byte and compare with the transmitted CRC byte.

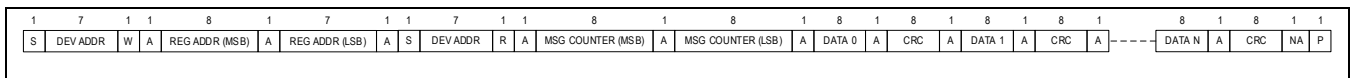

Figure 50. I<sup>2</sup>C Multiple-Byte Read with CRC

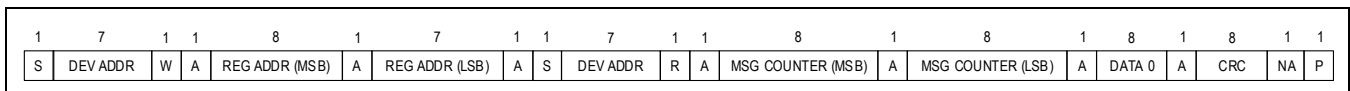

Figure 51. I<sup>2</sup>C Single-Byte Read with CRC

**Message Counter Writes**

An additional functional safety feature of the MAX96792A is a Message Counter, which can be used with the I<sup>2</sup>C/UART CRC feature. If enabled, the device expects a 2-byte message count from the μC, indicating the number of writes being sent. The MAX96792A counts the number of write transactions and compares it with the count sent by the μC. If the two counts match, the write is accepted. If the two counts do not match, the write is rejected, a NACK is sent in return, and the error counter is incremented. A programmable threshold for the error counter asserts ERRB, when reached.

**Message Counter Reads**

For read transactions, the MAX96792A sends the Message Counter value to the μC along with the requested data. The μC should compare the sent message count against its stored value and accept the data if the counts match. Note that a read transaction has a repeated start condition, with the device address byte sent twice. This results in each read transaction incrementing the Message Counter twice, once for each device address byte. If the two Message Counter values do not agree, the data should be rejected.

If a read is requested from the last used registers address, resulting in only one device address byte, the Message Counter is incremented once.

If the Message Counter values for the MAX96792A and μC do not agree, the device's Message Counter can be reset using a register write and the μC's counter should also be reset. If the μC is reset, or if its Message Counter is reset for any reason, the devices' counter must be reset using a register write as well.

**UART Writes with CRC**

To provide additional functional safety for ADAS applications, the MAX96792A supports the addition of a CRC to UART transactions. When enabled, the main  $\mu\text{C}$  must compute and send a CRC byte after each data byte. See [Figure 52](#). For each single-byte or multibyte write, first clear the CRC engine. The first CRC includes the sync frame, device address byte, register address bytes, message counter bytes, and the first data byte. All bytes are sent LSB first. For all following data bytes, the CRC engine is reset, and the CRC byte covers the additional data byte. See [Figure 53](#) and [Figure 54](#). The MAX96792A receives the data byte, calculates the CRC using an identical CRC engine, and verifies a match before accepting the data byte. If the CRCs do not match, a write is not accepted, a NACK is transmitted, and the error counter is triggered.

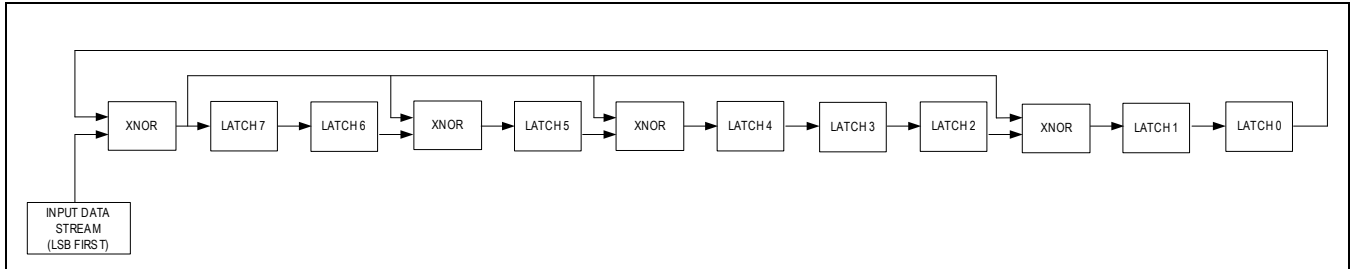

Figure 52. UART CRC Engine

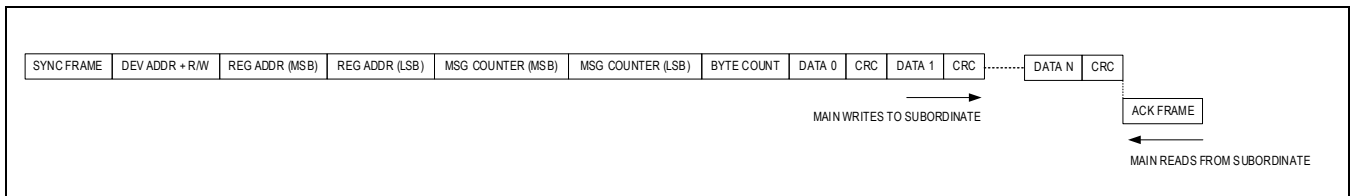

Figure 53. UART Multiple-Byte Write Transactions with CRC

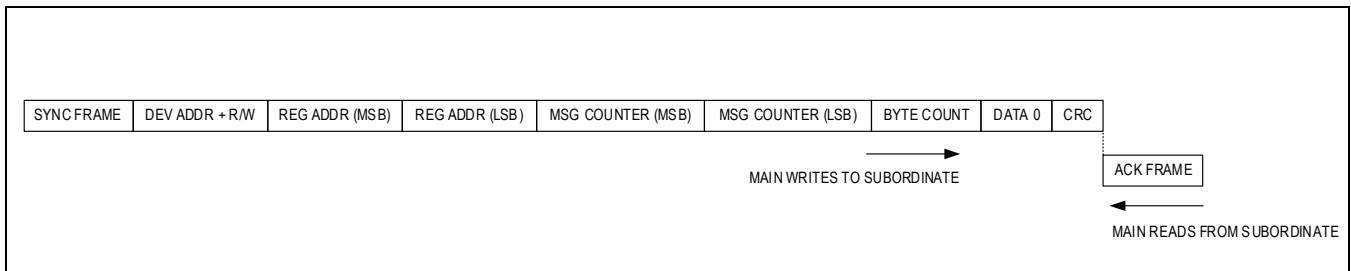

Figure 54. UART Single-Byte Write Transaction with CRC

**UART Reads with CRC**

For UART reads of MAX96792A's registers, the device's CRC engine clears and then uses the outgoing sync frame, device address byte, register address bytes, message counter bytes, and the first data byte to calculate the CRC byte. This is added to the data stream directly after the corresponding data byte. All bytes are sent LSB first. The CRC engine is subsequently cleared again for all other data bytes. See [Figure 55](#) and [Figure 56](#). When the  $\mu\text{C}$  receives the UART read data, either through the serializer on the other side of the link or directly from the MAX96792A, the  $\mu\text{C}$ 's CRC engine can calculate a CRC byte for each data byte and compare with the transmitted CRC byte. The ACK frame is not included in the CRC calculation because the  $\mu\text{C}$  is looking for the ACK value of 0xC3. If there is an error, the  $\mu\text{C}$  treats the frame as a NACK and rejects the data. Note that the read command from the  $\mu\text{C}$  does not include CRC.

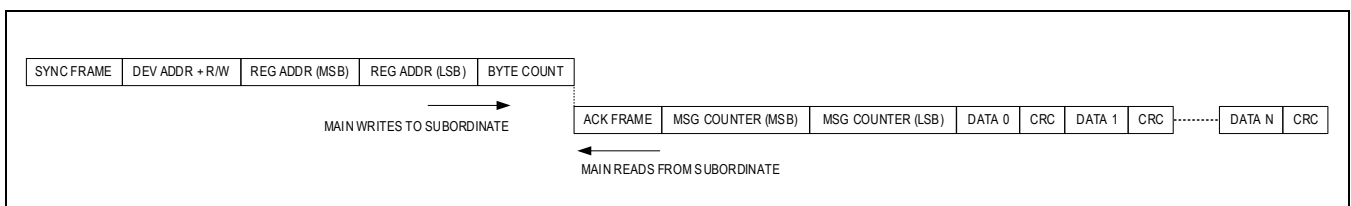

Figure 55. UART Multiple-Byte Read Transaction with CRC

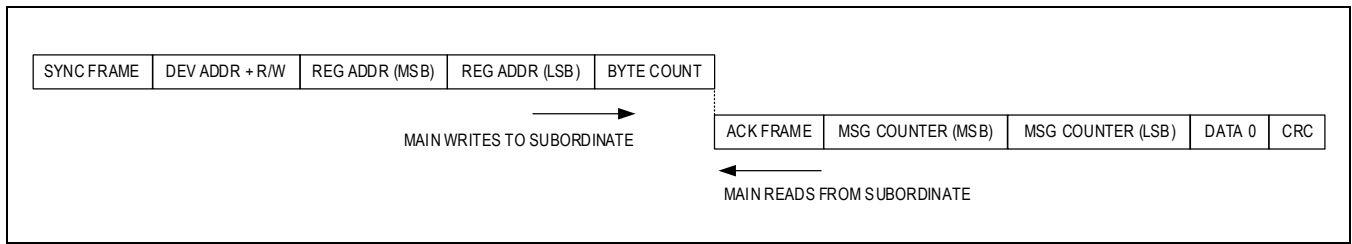
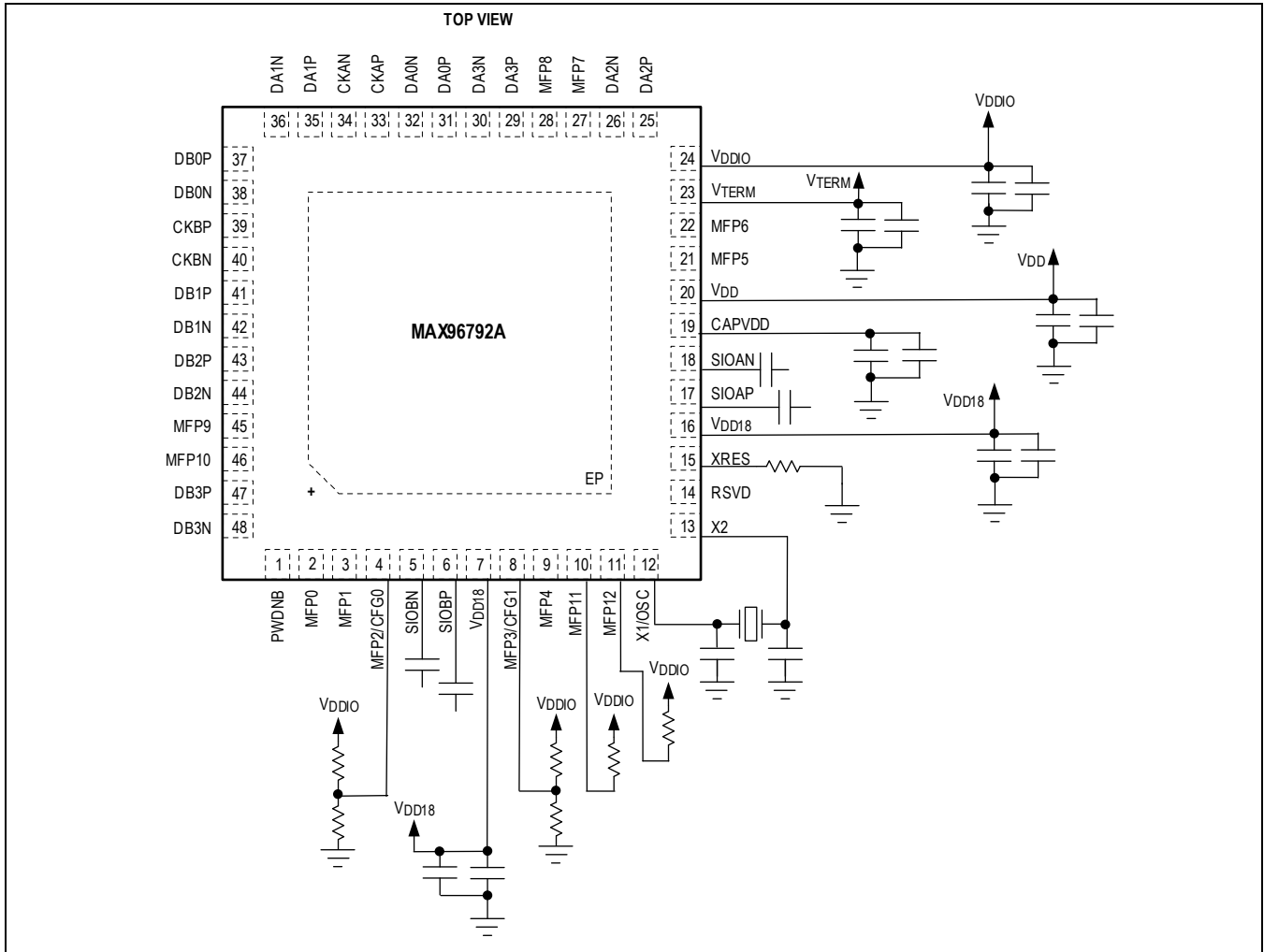

Figure 56. UART Single-Byte Read Transaction with CRC

Typical Application Circuits

See [Table 3](#).



Ordering Information

| PART NUMBER       | TEMP RANGE      | PIN-PACKAGE    |
|-------------------|-----------------|----------------|
| MAX96792AGTM/VY+  | -40°C to +105°C | 48-Pin SW TQFN |
| MAX96792AGTM/VY+T | -40°C to +105°C | 48-Pin SW TQFN |

+ Denotes a lead(Pb)-free/RoHS-compliant package.

T = Tape and reel

/V Denotes automotive qualified

Y Denotes side-wettable flank

## Register Map

MAX96792A

### Reserved, Unused, and Read-Only Register Bits

Not all register bits in the register space are shown in the register table. Any bit not explicitly defined in the register table should be treated as reserved and not be modified. When a write is required to a register with both defined and undefined register bits, first read the register's contents, then create a new register value by only changing the defined bits, and finally, write the new byte to the register (Read/Replace/Write).

In this document, default values are provided for read-only register bits. Read-only bit states are changed at power-up according to the actual state of the device. To avoid overwriting these bits, treat read-only bits as undefined.

See [Programming Notes section for important mandatory register writes on start-up](#).

Note: \*Indicates the register is stored when entering sleep mode and is restored upon exit.

| AD<br>DR<br>ES<br>S | R<br>E<br>S<br>E<br>T | NAME                       | MSB                  |          |                    |                |                |                  |                | LSB       |  |
|---------------------|-----------------------|----------------------------|----------------------|----------|--------------------|----------------|----------------|------------------|----------------|-----------|--|
| <b>DEV</b>          |                       |                            |                      |          |                    |                |                |                  |                |           |  |
| 0x0<br>0            | 0x<br>90              | <a href="#">REG0[7:0]</a>  | DEV_ADDR[6:0]        |          |                    |                |                |                  |                | CFG_BLOCK |  |
| 0x0<br>1            | 0x<br>02              | <a href="#">REG1[7:0]</a>  | IIC_2_EN             | IIC_1_EN | DIS_LOCAL_CC       | DIS_REM_C<br>C | TX_RATE[1:0]   |                  | RX_RATE[1:0]   |           |  |
| 0x0<br>2            | 0x<br>63              | <a href="#">REG2[7:0]</a>  | –                    | VID_EN_Z | VID_EN_Y           | –              | –              | –                | –              | –         |  |
| 0x0<br>3            | 0x<br>53              | <a href="#">REG3[7:0]</a>  | LOCK_CFG             | PT_SWAP  | UART_2_EN          | UART_1_E<br>N  | –              | DIS_REM_CC<br>_B | –              | –         |  |
| 0x0<br>4            | 0x<br>C2              | <a href="#">REG4[7:0]</a>  | GMSL3_B              | GMSL3_A  | –                  | –              | TX_RATE_B[1:0] |                  | RX_RATE_B[1:0] |           |  |
| 0x0<br>5            | 0x<br>C0              | <a href="#">REG5[7:0]</a>  | LOCK_EN              | ERRB_EN  | LOCK_ALT_E<br>N    | –              | PU_LF3         | PU_LF2           | PU_LF1         | PU_LF0    |  |
| 0x0<br>6            | 0x<br>C0              | <a href="#">REG6[7:0]</a>  | GMSL2_B              | GMSL2_A  | DIS_REM_CC<br>_2_B | I2CSEL         | –              | –                | –              | –         |  |
| 0x0<br>7            | 0x<br>27              | <a href="#">REG7[7:0]</a>  | CMP_VTER<br>M_STATUS | –        | –                  | –              | –              | –                | –              | –         |  |
| 0x0<br>D            | 0x<br>B6              | <a href="#">REG13[7:0]</a> | DEV_ID[7:0]          |          |                    |                |                |                  |                |           |  |

| AD DR ES S   | R E S E T | NAME                              | MSB                |                    |                     |                 |                         |                  |                | LSB              |  |
|--------------|-----------|-----------------------------------|--------------------|--------------------|---------------------|-----------------|-------------------------|------------------|----------------|------------------|--|
| 0x0<br>E     | 0x<br>03  | <a href="#">REG14[7:0]</a>        | -                  | -                  | -                   | -               | DEV_REV[3:0]            |                  |                |                  |  |
| 0x0<br>F     | 0x<br>00  | <a href="#">REG15[7:0]</a>        | -                  | -                  | -                   | -               | -                       | -                | -              | GMSL1_CP<br>BL   |  |
| 0x2<br>6     | 0x<br>22  | <a href="#">REG26[7:0]</a>        | -                  | LF_1[2:0]          |                     |                 | -                       | LF_0[2:0]        |                |                  |  |
| 0x2<br>7     | 0x<br>22  | <a href="#">REG27[7:0]</a>        | -                  | LF_3[2:0]          |                     |                 | -                       | LF_2[2:0]        |                |                  |  |
| 0x3<br>8     | 0x<br>00  | <a href="#">IO_CHK0[7:0]</a><br>1 | PIN_DRV_EN_0[7:0]  |                    |                     |                 |                         |                  |                |                  |  |
| OVERLAP      |           |                                   |                    |                    |                     |                 |                         |                  |                |                  |  |
| <b>TCTRL</b> |           |                                   |                    |                    |                     |                 |                         |                  |                |                  |  |
| 0x0<br>8     | 0x<br>00  | <a href="#">PWR0[7:0]</a>         | VDDBAD_STATUS[2:0] |                    |                     | CMP_STATUS[4:0] |                         |                  |                |                  |  |
| 0x0<br>9     | 0x<br>00  | <a href="#">PWR1[7:0]</a>         | -                  | -                  | PORZ_STATUS[5:0]    |                 |                         |                  |                |                  |  |
| 0x0<br>C     | 0x<br>15  | <a href="#">PWR4[7:0]</a>         | -                  | DIS_LOCA<br>L_WAKE | WAKE_EN_B           | WAKE_EN_<br>A   | -                       | -                | -              | -                |  |
| 0x1<br>0     | 0x<br>11  | <a href="#">CTRL0[7:0]</a>        | RESET_ALL          | RESET_LI<br>NK     | RESET_ONE<br>SHOT   | AUTO_LINK       | SLEEP                   | REG_ENABLE       | LINK_CFG[1:0]  |                  |  |
| 0x1<br>1     | 0x<br>0A  | <a href="#">CTRL1[7:0]</a>        | -                  | -                  | -                   | -               | -                       | CXTP_B           | -              | CXTP_A           |  |
| 0x1<br>2     | 0x<br>04  | <a href="#">CTRL2[7:0]</a>        | -                  | -                  | RESET_ONE<br>SHOT_B | REG_MNL         | -                       | -                | -              | -                |  |
| 0x1<br>3     | 0x<br>10  | <a href="#">CTRL3[7:0]</a>        | -                  | -                  | LINK_MODE[1:0]      |                 | LOCKED                  | ERROR            | CMU_LOCK<br>ED | RESET_LI<br>NK_B |  |
| 0x1<br>8     | 0x<br>A0  | <a href="#">INTR0[7:0]</a>        | -                  | -                  | -                   | -               | AUTO_ER<br>R_RST_E<br>N | DEC_ERR_THR[2:0] |                |                  |  |
| 0x1<br>9     | 0x<br>00  | <a href="#">INTR1[7:0]</a>        | PKT_CNT_EXP[3:0]   |                    |                     |                 | AUTO_CN<br>T_RST_EN     | PKT_CNT_THR[2:0] |                |                  |  |

| ADDRESS     | REGISTER | NAME                       | MSB             |                |                 |                |                 |                |                | LSB                 |
|-------------|----------|----------------------------|-----------------|----------------|-----------------|----------------|-----------------|----------------|----------------|---------------------|
| 0x1A        | 0x0B     | <a href="#">INTR2[7:0]</a> | -               | -              | REM_ERR_OEN     | -              | LFLT_INT_OEN    | IDLE_ERR_OEN   | DEC_ERR_OEN_B  | DEC_ERR_OEN_A       |
| 0x1B        | 0x00     | <a href="#">INTR3[7:0]</a> | -               | -              | REM_ERR_FLAG    | -              | LFLT_INT        | IDLE_ERR_FLAG  | DEC_ERR_FLAG_B | DEC_ERR_FLAG_A      |
| 0x1C        | 0x09     | <a href="#">INTR4[7:0]</a> | EOM_ERR_OEN_B   | EOM_ERR_OEN_A  | FEC_RX_ERR_OEN  | -              | MAX_RT_OEN      | RT_CNT_OEN     | PKT_CNT_OEN    | WM_ERR_OEN          |
| 0x1D        | 0x00     | <a href="#">INTR5[7:0]</a> | EOM_ERR_FLAG_B  | EOM_ERR_FLAG_A | FEC_RX_ERR_FLAG | -              | MAX_RT_FLAG     | RT_CNT_FLAG    | PKT_CNT_FLAG   | WM_ERR_FLAG         |
| 0x1E        | 0x1C     | <a href="#">INTR6[7:0]</a> | VDDCMP_INT_OEN  | -              | VDDBAD_INT_OEN  | FSYNC_ERR_OEN  | LCRC_ERR_OEN    | VPRBS_ERR_OEN  | -              | VID_PXL_CRC_ERR_OEN |
| 0x1F        | 0x00     | <a href="#">INTR7[7:0]</a> | VDDCMP_INT_FLAG | -              | VDDBAD_INT_FLAG | FSYNC_ERR_FLAG | LCRC_ERR_FLAG   | VPRBS_ERR_FLAG | -              | VID_PXL_CRC_ERR     |
| 0x20        | 0xFF     | <a href="#">INTR8[7:0]</a> | ERR_TX_EN       | -              | ERR_TX_EN_B     | ERR_TX_ID[4:0] |                 |                |                |                     |
| 0x21        | 0xFF     | <a href="#">INTR9[7:0]</a> | ERR_RX_EN       | -              | ERR_RX_EN_B     | ERR_RX_ID[4:0] |                 |                |                |                     |
| 0x22        | 0x00     | <a href="#">CNT0[7:0]</a>  | DEC_ERR_A[7:0]  |                |                 |                |                 |                |                |                     |
| 0x23        | 0x00     | <a href="#">CNT1[7:0]</a>  | DEC_ERR_B[7:0]  |                |                 |                |                 |                |                |                     |
| 0x24        | 0x00     | <a href="#">CNT2[7:0]</a>  | IDLE_ERR[7:0]   |                |                 |                |                 |                |                |                     |
| 0x25        | 0x00     | <a href="#">CNT3[7:0]</a>  | PKT_CNT[7:0]    |                |                 |                |                 |                |                |                     |
| <b>GMSL</b> |          |                            |                 |                |                 |                |                 |                |                |                     |
| 0x28        | 0x60     | <a href="#">TX0[7:0]</a>   | -               | -              | -               | -              | -               | -              | RX_FEC_EN      | -                   |
| 0x29        | 0x08     | <a href="#">TX1[7:0]</a>   | LINK_PRBS_GEN   | -              | -               | ERRG_EN_A      | -               | -              | -              | -                   |
| 0x2A        | 0x20     | <a href="#">TX2[7:0]</a>   | ERRG_CNT[1:0]   |                | ERRG_RATE[1:0]  |                | ERRG_BURST[2:0] |                |                | ERRG_PER            |

| ADDRESS   | RESET | NAME                        | MSB               |                  |                    |                    |                  |                |               | LSB           |
|-----------|-------|-----------------------------|-------------------|------------------|--------------------|--------------------|------------------|----------------|---------------|---------------|
| 0x2B      | 0x44  | <a href="#">TX3[7:0]</a>    | -                 | -                | RX_FEC_ACTIVE      | -                  | -                | -              | -             | -             |
| 0x2C      | 0x00  | <a href="#">RX0[7:0]</a>    | PKT_CNT_LBW[1:0]  |                  | -                  | -                  | PKT_CNT_SEL[3:0] |                |               |               |
| 0x2D      | 0x28  | <a href="#">RX1[7:0]</a>    | LINK_PRBS_CHK     | -                | -                  | -                  | -                | -              | -             | -             |
| 0x2F      | 0x00  | <a href="#">RX3[7:0]</a>    | -                 | -                | -                  | LINK_PRBS_CHK_PAM4 | -                | -              | -             | -             |
| 0x30      | 0x41  | <a href="#">GPIOA[7:0]</a>  | -                 | -                | GPIO_FWD_CDLY[5:0] |                    |                  |                |               |               |
| 0x31      | 0x88  | <a href="#">GPIOB[7:0]</a>  | GPIO_TX_WNDW[1:0] |                  | GPIO_REV_CDLY[5:0] |                    |                  |                |               |               |
| <b>CC</b> |       |                             |                   |                  |                    |                    |                  |                |               |               |
| 0x40      | 0x26  | <a href="#">I2C_0[7:0]</a>  | -                 | -                | SLV_SH[1:0]        | -                  | SLV_TO[2:0]      |                |               |               |
| 0x41      | 0x56  | <a href="#">I2C_1[7:0]</a>  | -                 | MST_BT[2:0]      |                    |                    | -                | MST_TO[2:0]    |               |               |
| 0x42      | 0x00  | <a href="#">I2C_2[7:0]</a>  | SRC_A[6:0]        |                  |                    |                    |                  |                |               | -             |
| 0x43      | 0x00  | <a href="#">I2C_3[7:0]</a>  | DST_A[6:0]        |                  |                    |                    |                  |                |               | -             |
| 0x44      | 0x00  | <a href="#">I2C_4[7:0]</a>  | SRC_B[6:0]        |                  |                    |                    |                  |                |               | -             |
| 0x45      | 0x00  | <a href="#">I2C_5[7:0]</a>  | DST_B[6:0]        |                  |                    |                    |                  |                |               | -             |
| 0x47      | 0x00  | <a href="#">I2C_7[7:0]</a>  | UART_RX_OVERFLOW  | UART_TX_OVERFLOW | -                  | -                  | -                | I2C_TIMED_OUT  | REM_ACK_ACKED | REM_ACK_RECVD |
| 0x48      | 0x42  | <a href="#">UART_0[7:0]</a> | -                 | -                | REM_MS_EN          | LOC_MS_EN          | BYPASS_DIS_PAR   | BYPASS_TO[1:0] |               | BYPASS_EN     |
| 0x49      | 0x96  | <a href="#">UART_1[7:0]</a> | BITLEN_LSB[7:0]   |                  |                    |                    |                  |                |               |               |

| ADDRESS             | RESET | NAME                           | MSB                  |                     |                 |             |                      |                     |               | LSB |
|---------------------|-------|--------------------------------|----------------------|---------------------|-----------------|-------------|----------------------|---------------------|---------------|-----|
| 0x4A                | 0x80  | <a href="#">UART_2[7:0]</a>    | OUT_DELAY[1:0]       |                     | BITLEN_MSB[5:0] |             |                      |                     |               |     |
| 0x4C                | 0x26  | <a href="#">I2C_PT_0[7:0]</a>  | -                    | -                   | SLV_SH_PT[1:0]  |             | -                    | SLV_TO_PT[2:0]      |               |     |
| 0x4D                | 0x56  | <a href="#">I2C_PT_1[7:0]</a>  | -                    | MST_BT_PT[2:0]      |                 |             | -                    | MST_TO_PT[2:0]      |               |     |
| 0x4E                | 0x00  | <a href="#">I2C_PT_2[7:0]</a>  | -                    | I2C_TIME<br>D_OUT_2 | -               | -           | -                    | I2C_TIMED_O<br>UT_1 | -             | -   |
| 0x4F                | 0x88  | <a href="#">UART_PT_0[7:0]</a> | BITLEN_MA<br>N_CFG_2 | DIS_PAR_<br>2       | -               | -           | BITLEN_M<br>AN_CFG_1 | DIS_PAR_1           | -             | -   |
| <b>CFGH VIDEO_X</b> |       |                                |                      |                     |                 |             |                      |                     |               |     |
| 0x50                | 0x00  | <a href="#">RX0[7:0]</a>       | RX_CRC_E<br>N        | -                   | -               | -           | -                    | -                   | STR_SEL[1:0]  |     |
| <b>CFGH VIDEO_Y</b> |       |                                |                      |                     |                 |             |                      |                     |               |     |
| 0x51                | 0x01  | <a href="#">RX0[7:0]</a>       | RX_CRC_E<br>N        | -                   | -               | -           | -                    | -                   | STR_SEL[1:0]  |     |
| <b>CFGH VIDEO_Z</b> |       |                                |                      |                     |                 |             |                      |                     |               |     |
| 0x52                | 0x02  | <a href="#">RX0[7:0]</a>       | RX_CRC_E<br>N        | -                   | -               | -           | -                    | -                   | STR_SEL[1:0]  |     |
| <b>CFGH VIDEO_U</b> |       |                                |                      |                     |                 |             |                      |                     |               |     |
| 0x53                | 0x03  | <a href="#">RX0[7:0]</a>       | RX_CRC_E<br>N        | -                   | -               | -           | -                    | -                   | STR_SEL[1:0]  |     |
| <b>CFGH INFOFR</b>  |       |                                |                      |                     |                 |             |                      |                     |               |     |
| 0x60                | 0xF0  | <a href="#">TR0[7:0]</a>       | TX_CRC_E<br>N        | RX_CRC_E<br>EN      | -               | -           | PRIO_VAL[1:0]        |                     | PRIO_CFG[1:0] |     |
| 0x61                | 0xB0  | <a href="#">TR1[7:0]</a>       | BW_MULT[1:0]         |                     |                 | BW_VAL[5:0] |                      |                     |               |     |
| 0x63                | 0x00  | <a href="#">TR3[7:0]</a>       | -                    | -                   | -               | -           | -                    | TX_SRC_ID[2:0]      |               |     |
| 0x64                | 0xFF  | <a href="#">TR4[7:0]</a>       | RX_SRC_SEL[7:0]      |                     |                 |             |                      |                     |               |     |

| AD<br>DR<br>ES<br>S | R<br>E<br>S<br>E<br>T | NAME                      | MSB             |               |                  |                |               |                      |                    | LSB            |
|---------------------|-----------------------|---------------------------|-----------------|---------------|------------------|----------------|---------------|----------------------|--------------------|----------------|
| <b>CFGL SPI</b>     |                       |                           |                 |               |                  |                |               |                      |                    |                |
| 0x6<br>8            | 0x<br>F0              | <a href="#">TR0[7:0]</a>  | TX_CRC_E<br>N   | RX_CRC_<br>EN | -                | -              | PRIO_VAL[1:0] | PRIO_CFG[1:0]        |                    |                |
| 0x6<br>9            | 0x<br>B0              | <a href="#">TR1[7:0]</a>  | BW_MULT[1:0]    |               |                  | BW_VAL[5:0]    |               |                      |                    |                |
| 0x6<br>B            | 0x<br>00              | <a href="#">TR3[7:0]</a>  | -               | -             | -                | -              | -             | TX_SRC_ID[2:0]       |                    |                |
| 0x6<br>C            | 0x<br>FF              | <a href="#">TR4[7:0]</a>  | RX_SRC_SEL[7:0] |               |                  |                |               |                      |                    |                |
| 0x6<br>D            | 0x<br>98              | <a href="#">ARQ0[7:0]</a> | -               | -             | MATCH_SRC<br>_ID | ACK_SRC_I<br>D | EN            | DIS_DBL_ACK<br>_RETX | -                  | -              |
| 0x6<br>E            | 0x<br>72              | <a href="#">ARQ1[7:0]</a> | -               | MAX_RT[2:0]   |                  |                | -             | -                    | MAX_RT_E<br>RR_OEN | RT_CNT_O<br>EN |
| 0x6<br>F            | 0x<br>00              | <a href="#">ARQ2[7:0]</a> | MAX_RT_E<br>RR  | RT_CNT[6:0]   |                  |                |               |                      |                    |                |
| <b>CFGC CC</b>      |                       |                           |                 |               |                  |                |               |                      |                    |                |
| 0x7<br>0            | 0x<br>F0              | <a href="#">TR0[7:0]</a>  | TX_CRC_E<br>N   | RX_CRC_<br>EN | -                | -              | PRIO_VAL[1:0] | PRIO_CFG[1:0]        |                    |                |
| 0x7<br>1            | 0x<br>B0              | <a href="#">TR1[7:0]</a>  | BW_MULT[1:0]    |               |                  | BW_VAL[5:0]    |               |                      |                    |                |
| 0x7<br>3            | 0x<br>00              | <a href="#">TR3[7:0]</a>  | -               | -             | -                | -              | -             | TX_SRC_ID[2:0]       |                    |                |
| 0x7<br>4            | 0x<br>FF              | <a href="#">TR4[7:0]</a>  | RX_SRC_SEL[7:0] |               |                  |                |               |                      |                    |                |
| 0x7<br>5            | 0x<br>98              | <a href="#">ARQ0[7:0]</a> | -               | -             | MATCH_SRC<br>_ID | ACK_SRC_I<br>D | EN            | DIS_DBL_ACK<br>_RETX | -                  | -              |
| 0x7<br>6            | 0x<br>72              | <a href="#">ARQ1[7:0]</a> | -               | MAX_RT[2:0]   |                  |                | -             | -                    | MAX_RT_E<br>RR_OEN | RT_CNT_O<br>EN |
| 0x7<br>7            | 0x<br>00              | <a href="#">ARQ2[7:0]</a> | MAX_RT_E<br>RR  | RT_CNT[6:0]   |                  |                |               |                      |                    |                |
| <b>CFGL GPIO</b>    |                       |                           |                 |               |                  |                |               |                      |                    |                |

| ADDRESS            | REGISTER | NAME                      | MSB             |             |              |            |               |                  |                | LSB       |  |
|--------------------|----------|---------------------------|-----------------|-------------|--------------|------------|---------------|------------------|----------------|-----------|--|
| 0x78               | 0xF0     | <a href="#">TR0[7:0]</a>  | TX_CRC_EN       | RX_CRC_EN   | -            | -          | PRIO_VAL[1:0] |                  | PRIO_CFG[1:0]  |           |  |
| 0x79               | 0xB0     | <a href="#">TR1[7:0]</a>  | BW_MULT[1:0]    |             |              |            | BW_VAL[5:0]   |                  |                |           |  |
| 0x7B               | 0x00     | <a href="#">TR3[7:0]</a>  | -               | -           | -            | -          | -             |                  | TX_SRC_ID[2:0] |           |  |
| 0x7C               | 0xFF     | <a href="#">TR4[7:0]</a>  | RX_SRC_SEL[7:0] |             |              |            |               |                  |                |           |  |
| 0x7D               | 0x98     | <a href="#">ARQ0[7:0]</a> | -               | -           | MATCH_SRC_ID | ACK_SRC_ID | EN            | DIS_DBL_ACK_RETX | -              | -         |  |
| 0x7E               | 0x72     | <a href="#">ARQ1[7:0]</a> | -               | MAX_RT[2:0] |              |            | -             | -                | MAX_RT_EN      | RT_CNT_EN |  |
| 0x7F               | 0x00     | <a href="#">ARQ2[7:0]</a> | MAX_RT_EN       | RT_CNT[6:0] |              |            |               |                  |                |           |  |
| <b>CFG_C IIC_X</b> |          |                           |                 |             |              |            |               |                  |                |           |  |
| 0x80               | 0xF0     | <a href="#">TR0[7:0]</a>  | TX_CRC_EN       | RX_CRC_EN   | -            | -          | PRIO_VAL[1:0] |                  | PRIO_CFG[1:0]  |           |  |
| 0x81               | 0xB0     | <a href="#">TR1[7:0]</a>  | BW_MULT[1:0]    |             |              |            | BW_VAL[5:0]   |                  |                |           |  |
| 0x83               | 0x00     | <a href="#">TR3[7:0]</a>  | -               | -           | -            | -          | -             |                  | TX_SRC_ID[2:0] |           |  |
| 0x84               | 0xFF     | <a href="#">TR4[7:0]</a>  | RX_SRC_SEL[7:0] |             |              |            |               |                  |                |           |  |
| 0x85               | 0x98     | <a href="#">ARQ0[7:0]</a> | -               | -           | MATCH_SRC_ID | ACK_SRC_ID | EN            | DIS_DBL_ACK_RETX | -              | -         |  |
| 0x86               | 0x72     | <a href="#">ARQ1[7:0]</a> | -               | MAX_RT[2:0] |              |            | -             | -                | MAX_RT_EN      | RT_CNT_EN |  |
| 0x87               | 0x00     | <a href="#">ARQ2[7:0]</a> | MAX_RT_EN       | RT_CNT[6:0] |              |            |               |                  |                |           |  |
| <b>CFG_C IIC_Y</b> |          |                           |                 |             |              |            |               |                  |                |           |  |
| 0x88               | 0xF0     | <a href="#">TR0[7:0]</a>  | TX_CRC_EN       | RX_CRC_EN   | -            | -          | PRIO_VAL[1:0] |                  | PRIO_CFG[1:0]  |           |  |

| ADDRESS         | RESET | NAME                            | MSB             |               |              |             |           |                  |                | LSB         |
|-----------------|-------|---------------------------------|-----------------|---------------|--------------|-------------|-----------|------------------|----------------|-------------|
| 0x89            | 0xB0  | <a href="#">TR1[7:0]</a>        | BW_MULT[1:0]    |               | BW_VAL[5:0]  |             |           |                  |                |             |
| 0x8B            | 0x00  | <a href="#">TR3[7:0]</a>        | -               | -             | -            | -           | -         | TX_SRC_ID[2:0]   |                |             |
| 0x8C            | 0xFF  | <a href="#">TR4[7:0]</a>        | RX_SRC_SEL[7:0] |               |              |             |           |                  |                |             |
| 0x8D            | 0x98  | <a href="#">ARQ0[7:0]</a>       | -               | -             | MATCH_SRC_ID | ACK_SRC_ID  | EN        | DIS_DBL_ACK_RETX | -              | -           |
| 0x8E            | 0x72  | <a href="#">ARQ1[7:0]</a>       | -               | MAX_RT[2:0]   |              |             | -         | -                | MAX_RT_ERR_OEN | RT_CNT_OEN  |
| 0x8F            | 0x00  | <a href="#">ARQ2[7:0]</a>       | MAX_RT_ERR      | RT_CNT[6:0]   |              |             |           |                  |                |             |
| <b>VID_RX Y</b> |       |                                 |                 |               |              |             |           |                  |                |             |
| 0x112           | 0x32  | <a href="#">VIDEO_RX0[7:0]</a>  | LCRC_ERR        | -             | -            | -           | -         | LINE_CRC_SEL     | LINE_CRC_EN    | DIS_PKT_DET |
| 0x115           | 0x40  | <a href="#">VIDEO_RX3[7:0]</a>  | -               | HD_TR_MODE    | DLOCKED      | VLOCKED     | HLOCKED   | DTRACKEN         | VTRACKEN       | HTRACKEN    |
| 0x118           | 0x02  | <a href="#">VIDEO_RX6[7:0]</a>  | -               | -             | -            | -           | LIM_HEART | -                | -              | -           |
| 0x11A           | 0x02  | <a href="#">VIDEO_RX8[7:0]</a>  | VID_BLK_LEN_ERR | VID_LOCK      | VID_PKT_DET  | VID_SEQ_ERR | -         | -                | -              | -           |
| 0x11C           | 0x00  | <a href="#">VIDEO_RX10[7:0]</a> | VID_OVERFLOW    | MASK_VIDEO_DE | -            | -           | -         | -                | -              | -           |
| <b>VID_RX Z</b> |       |                                 |                 |               |              |             |           |                  |                |             |
| 0x124           | 0x32  | <a href="#">VIDEO_RX0[7:0]</a>  | LCRC_ERR        | -             | -            | -           | -         | LINE_CRC_SEL     | LINE_CRC_EN    | DIS_PKT_DET |
| 0x127           | 0x40  | <a href="#">VIDEO_RX3[7:0]</a>  | -               | HD_TR_MODE    | DLOCKED      | VLOCKED     | HLOCKED   | DTRACKEN         | VTRACKEN       | HTRACKEN    |
| 0x12A           | 0x02  | <a href="#">VIDEO_RX6[7:0]</a>  | -               | -             | -            | -           | LIM_HEART | -                | -              | -           |
| 0x12C           | 0x02  | <a href="#">VIDEO_RX8[7:0]</a>  | VID_BLK_LEN_ERR | VID_LOCK      | VID_PKT_DET  | VID_SEQ_ERR | -         | -                | -              | -           |

| AD DR ES S            | R E S E T | NAME                                | MSB                   |                   |                       |                    |                 |                       |                    | LSB                |
|-----------------------|-----------|-------------------------------------|-----------------------|-------------------|-----------------------|--------------------|-----------------|-----------------------|--------------------|--------------------|
| 0x12E                 | 0x00      | <a href="#">VIDEO_RX1_0[7:0]</a>    | VID_OVERF<br>LOW      | MASK_VI<br>DEO_DE | -                     | -                  | -               | -                     | -                  | -                  |
| <b>VIDEO_PIPE_SEL</b> |           |                                     |                       |                   |                       |                    |                 |                       |                    |                    |
| 0x160                 | 0x03      | <a href="#">VIDEO_PIPE_EN[7:0]</a>  | -                     | -                 | -                     | -                  | -               | -                     | -                  | VIDEO_PIPE_EN[1:0] |
| 0x161                 | 0x32      | <a href="#">VIDEO_PIPE_SEL[7:0]</a> | -                     | -                 | VIDEO_PIPE_SEL_Z[2:0] |                    |                 | VIDEO_PIPE_SEL_Y[2:0] |                    |                    |
| 0x162                 | 0x00      | <a href="#">LINK_SEL[7:0]</a>       | -                     | -                 | -                     | -                  | SPI_LINK_SELECT | UART_2_LINK_SELECT    | UART_1_LINK_SELECT | UART_0_LINK_SELECT |
| <b>SPI</b>            |           |                                     |                       |                   |                       |                    |                 |                       |                    |                    |
| 0x170                 | 0x08      | <a href="#">SPI_0[7:0]</a>          | SPI_LOC_ID[1:0]       |                   | SPI_CC_TRG_ID[1:0]    |                    | SPI_IGNR_ID     | SPI_CC_EN             | MST_SLVN           | SPI_EN             |
| 0x171                 | 0x1D      | <a href="#">SPI_1[7:0]</a>          | SPI_LOC_N[5:0]        |                   |                       |                    |                 |                       | SPI_BASE_Prio[1:0] |                    |
| 0x172                 | 0x03      | <a href="#">SPI_2[7:0]</a>          | REQ_HOLD_OFF[2:0]     |                   |                       | FULL_SCK_SETUP     | SPI_MOD3_F      | SPI_MOD3              | SPIM_SS2_ACT_H     | SPIM_SS1_ACT_H     |
| 0x173                 | 0x00      | <a href="#">SPI_3[7:0]</a>          | SPIM_SS_DLY_CLKS[7:0] |                   |                       |                    |                 |                       |                    |                    |
| 0x174                 | 0x00      | <a href="#">SPI_4[7:0]</a>          | SPIM_SCK_LO_CLKS[7:0] |                   |                       |                    |                 |                       |                    |                    |
| 0x175                 | 0x00      | <a href="#">SPI_5[7:0]</a>          | SPIM_SCK_HI_CLKS[7:0] |                   |                       |                    |                 |                       |                    |                    |
| 0x176                 | 0x00      | <a href="#">SPI_6[7:0]</a>          | -                     | -                 | BNE                   | SPIS_RWN           | SS_IO_EN_2      | SS_IO_EN_1            | BNE_IO_EN          | RWN_IO_EN          |
| 0x177                 | 0x00      | <a href="#">SPI_7[7:0]</a>          | SPI_RX_OVRFLW         | SPI_TX_OVRFLW     | RO_ALT                | SPIS_BYTE_CNT[4:0] |                 |                       |                    |                    |
| 0x178                 | 0x00      | <a href="#">SPI_8[7:0]</a>          | REQ_HOLD_OFF_TO[7:0]  |                   |                       |                    |                 |                       |                    |                    |
| <b>WM</b>             |           |                                     |                       |                   |                       |                    |                 |                       |                    |                    |

| AD<br>DR<br>ES<br>S | R<br>E<br>S<br>E<br>T | NAME                           | MSB            |              |          |             |             |          |                  | LSB          |
|---------------------|-----------------------|--------------------------------|----------------|--------------|----------|-------------|-------------|----------|------------------|--------------|
| 0x1<br>90           | 0x<br>00              | <a href="#">WM_0[7:0]</a>      | WM_LEN         | WM_MODE[2:0] |          |             | WM_DET[1:0] |          | -                | WM_EN        |
| 0x1<br>92           | 0x<br>50              | <a href="#">WM_2[7:0]</a>      | -              | -            | -        | -           | HsyncPol    | VsyncPol | WM_NPFILT[1:0]   |              |
| 0x1<br>94           | 0x<br>10              | <a href="#">WM_4[7:0]</a>      | -              | -            | -        | -           | -           | -        | WM_MASKMODE[1:0] |              |
| 0x1<br>95           | 0x<br>00              | <a href="#">WM_5[7:0]</a>      | -              | -            | -        | -           | -           | -        | WM_DETOU<br>T    | WM_ERRO<br>R |
| 0x1<br>96           | 0x<br>00              | <a href="#">WM_6[7:0]</a>      | WM_TIMER[7:0]  |              |          |             |             |          |                  |              |
| 0x1<br>AE           | 0x<br>00              | <a href="#">WM_WREN_0[7:0]</a> | WM_WREN_L[7:0] |              |          |             |             |          |                  |              |
| 0x1<br>AF           | 0x<br>00              | <a href="#">WM_WREN_1[7:0]</a> | WM_WREN_H[7:0] |              |          |             |             |          |                  |              |
| <b>VRX Y</b>        |                       |                                |                |              |          |             |             |          |                  |              |
| 0x1<br>E0           | 0x<br>00              | <a href="#">CROSS_0[7:0]</a>   | -              | CROSS0_I     | CROSS0_F | CROSS0[4:0] |             |          |                  |              |
| 0x1<br>E1           | 0x<br>01              | <a href="#">CROSS_1[7:0]</a>   | -              | CROSS1_I     | CROSS1_F | CROSS1[4:0] |             |          |                  |              |
| 0x1<br>E2           | 0x<br>02              | <a href="#">CROSS_2[7:0]</a>   | -              | CROSS2_I     | CROSS2_F | CROSS2[4:0] |             |          |                  |              |
| 0x1<br>E3           | 0x<br>03              | <a href="#">CROSS_3[7:0]</a>   | -              | CROSS3_I     | CROSS3_F | CROSS3[4:0] |             |          |                  |              |
| 0x1<br>E4           | 0x<br>04              | <a href="#">CROSS_4[7:0]</a>   | -              | CROSS4_I     | CROSS4_F | CROSS4[4:0] |             |          |                  |              |
| 0x1<br>E5           | 0x<br>05              | <a href="#">CROSS_5[7:0]</a>   | -              | CROSS5_I     | CROSS5_F | CROSS5[4:0] |             |          |                  |              |
| 0x1<br>E6           | 0x<br>06              | <a href="#">CROSS_6[7:0]</a>   | -              | CROSS6_I     | CROSS6_F | CROSS6[4:0] |             |          |                  |              |
| 0x1<br>E7           | 0x<br>07              | <a href="#">CROSS_7[7:0]</a>   | -              | CROSS7_I     | CROSS7_F | CROSS7[4:0] |             |          |                  |              |

| AD<br>DR<br>ES<br>S | R<br>E<br>S<br>E<br>T | NAME                                | MSB |               |           |              |  |  | LSB |
|---------------------|-----------------------|-------------------------------------|-----|---------------|-----------|--------------|--|--|-----|
| 0x1<br>E8           | 0x<br>08              | <a href="#">CROSS_8[7:<br/>0]</a>   | -   | CROSS8_I      | CROSS8_F  | CROSS8[4:0]  |  |  |     |
| 0x1<br>E9           | 0x<br>09              | <a href="#">CROSS_9[7:<br/>0]</a>   | -   | CROSS9_I      | CROSS9_F  | CROSS9[4:0]  |  |  |     |
| 0x1<br>EA           | 0x<br>0A              | <a href="#">CROSS_10[7:<br/>:0]</a> | -   | CROSS10<br>_I | CROSS10_F | CROSS10[4:0] |  |  |     |
| 0x1<br>EB           | 0x<br>0B              | <a href="#">CROSS_11[7:<br/>:0]</a> | -   | CROSS11<br>_I | CROSS11_F | CROSS11[4:0] |  |  |     |
| 0x1<br>EC           | 0x<br>0C              | <a href="#">CROSS_12[7:<br/>:0]</a> | -   | CROSS12<br>_I | CROSS12_F | CROSS12[4:0] |  |  |     |
| 0x1<br>ED           | 0x<br>0D              | <a href="#">CROSS_13[7:<br/>:0]</a> | -   | CROSS13<br>_I | CROSS13_F | CROSS13[4:0] |  |  |     |
| 0x1<br>EE           | 0x<br>0E              | <a href="#">CROSS_14[7:<br/>:0]</a> | -   | CROSS14<br>_I | CROSS14_F | CROSS14[4:0] |  |  |     |
| 0x1<br>EF           | 0x<br>0F              | <a href="#">CROSS_15[7:<br/>:0]</a> | -   | CROSS15<br>_I | CROSS15_F | CROSS15[4:0] |  |  |     |
| 0x1<br>F0           | 0x<br>10              | <a href="#">CROSS_16[7:<br/>:0]</a> | -   | CROSS16<br>_I | CROSS16_F | CROSS16[4:0] |  |  |     |
| 0x1<br>F1           | 0x<br>11              | <a href="#">CROSS_17[7:<br/>:0]</a> | -   | CROSS17<br>_I | CROSS17_F | CROSS17[4:0] |  |  |     |
| 0x1<br>F2           | 0x<br>12              | <a href="#">CROSS_18[7:<br/>:0]</a> | -   | CROSS18<br>_I | CROSS18_F | CROSS18[4:0] |  |  |     |
| 0x1<br>F3           | 0x<br>13              | <a href="#">CROSS_19[7:<br/>:0]</a> | -   | CROSS19<br>_I | CROSS19_F | CROSS19[4:0] |  |  |     |
| 0x1<br>F4           | 0x<br>14              | <a href="#">CROSS_20[7:<br/>:0]</a> | -   | CROSS20<br>_I | CROSS20_F | CROSS20[4:0] |  |  |     |
| 0x1<br>F5           | 0x<br>15              | <a href="#">CROSS_21[7:<br/>:0]</a> | -   | CROSS21<br>_I | CROSS21_F | CROSS21[4:0] |  |  |     |
| 0x1<br>F6           | 0x<br>16              | <a href="#">CROSS_22[7:<br/>:0]</a> | -   | CROSS22<br>_I | CROSS22_F | CROSS22[4:0] |  |  |     |

| AD<br>DR<br>ES<br>S | R<br>E<br>S<br>E<br>T | NAME                          | MSB                |            |            |                  |   |   |   | LSB            |
|---------------------|-----------------------|-------------------------------|--------------------|------------|------------|------------------|---|---|---|----------------|
| 0x1<br>F7           | 0x<br>17              | <a href="#">CROSS_23[7:0]</a> | -                  | CROSS23_I  | CROSS23_F  | CROSS23[4:0]     |   |   |   |                |
| 0x1<br>F8           | 0x<br>18              | <a href="#">CROSS_HS[7:0]</a> | -                  | CROSS_HS_I | CROSS_HS_F | CROSS_HS[4:0]    |   |   |   |                |
| 0x1<br>F9           | 0x<br>19              | <a href="#">CROSS_VS[7:0]</a> | -                  | CROSS_VS_I | CROSS_VS_F | CROSS_VS[4:0]    |   |   |   |                |
| 0x1<br>FA           | 0x<br>1A              | <a href="#">CROSS_DE[7:0]</a> | -                  | CROSS_DE_I | CROSS_DE_F | CROSS_DE[4:0]    |   |   |   |                |
| 0x1<br>FB           | 0x<br>00              | <a href="#">PRBS_ERR[7:0]</a> | VPRBS_ERR[7:0]     |            |            |                  |   |   |   |                |
| 0x1<br>FC           | 0x<br>80              | <a href="#">VPRBS[7:0]</a>    | PATGEN_C<br>LK_SRC | -          | VPRBS_FAIL | VPRBS_CH<br>K_EN | - | - | - | VIDEO_LO<br>CK |
| 0x1<br>FD           | 0x<br>1B              | <a href="#">CROSS_27[7:0]</a> | ALT_CROS<br>SBAR   | CROSS27_I  | CROSS27_F  | CROSS27[4:0]     |   |   |   |                |
| 0x1<br>FE           | 0x<br>1C              | <a href="#">CROSS_28[7:0]</a> | -                  | CROSS28_I  | CROSS28_F  | CROSS28[4:0]     |   |   |   |                |
| 0x1<br>FF           | 0x<br>1D              | <a href="#">CROSS_29[7:0]</a> | -                  | CROSS29_I  | CROSS29_F  | CROSS29[4:0]     |   |   |   |                |
| <b>VRX Z</b>        |                       |                               |                    |            |            |                  |   |   |   |                |
| 0x2<br>00           | 0x<br>00              | <a href="#">CROSS_0[7:0]</a>  | -                  | CROSS0_I   | CROSS0_F   | CROSS0[4:0]      |   |   |   |                |
| 0x2<br>01           | 0x<br>01              | <a href="#">CROSS_1[7:0]</a>  | -                  | CROSS1_I   | CROSS1_F   | CROSS1[4:0]      |   |   |   |                |
| 0x2<br>02           | 0x<br>02              | <a href="#">CROSS_2[7:0]</a>  | -                  | CROSS2_I   | CROSS2_F   | CROSS2[4:0]      |   |   |   |                |
| 0x2<br>03           | 0x<br>03              | <a href="#">CROSS_3[7:0]</a>  | -                  | CROSS3_I   | CROSS3_F   | CROSS3[4:0]      |   |   |   |                |
| 0x2<br>04           | 0x<br>04              | <a href="#">CROSS_4[7:0]</a>  | -                  | CROSS4_I   | CROSS4_F   | CROSS4[4:0]      |   |   |   |                |
| 0x2<br>05           | 0x<br>05              | <a href="#">CROSS_5[7:0]</a>  | -                  | CROSS5_I   | CROSS5_F   | CROSS5[4:0]      |   |   |   |                |

| AD<br>DR<br>ES<br>S | R<br>E<br>S<br>E<br>T | NAME                                | MSB |               |           |              |  | LSB |
|---------------------|-----------------------|-------------------------------------|-----|---------------|-----------|--------------|--|-----|
| 0x2<br>06           | 0x<br>06              | <a href="#">CROSS_6[7:<br/>0]</a>   | -   | CROSS6_I      | CROSS6_F  | CROSS6[4:0]  |  |     |
| 0x2<br>07           | 0x<br>07              | <a href="#">CROSS_7[7:<br/>0]</a>   | -   | CROSS7_I      | CROSS7_F  | CROSS7[4:0]  |  |     |
| 0x2<br>08           | 0x<br>08              | <a href="#">CROSS_8[7:<br/>0]</a>   | -   | CROSS8_I      | CROSS8_F  | CROSS8[4:0]  |  |     |
| 0x2<br>09           | 0x<br>09              | <a href="#">CROSS_9[7:<br/>0]</a>   | -   | CROSS9_I      | CROSS9_F  | CROSS9[4:0]  |  |     |
| 0x2<br>0A           | 0x<br>0A              | <a href="#">CROSS_10[7:<br/>:0]</a> | -   | CROSS10<br>_I | CROSS10_F | CROSS10[4:0] |  |     |
| 0x2<br>0B           | 0x<br>0B              | <a href="#">CROSS_11[7:<br/>:0]</a> | -   | CROSS11<br>_I | CROSS11_F | CROSS11[4:0] |  |     |
| 0x2<br>0C           | 0x<br>0<br>C          | <a href="#">CROSS_12[7:<br/>:0]</a> | -   | CROSS12<br>_I | CROSS12_F | CROSS12[4:0] |  |     |
| 0x2<br>0D           | 0x<br>0<br>D          | <a href="#">CROSS_13[7:<br/>:0]</a> | -   | CROSS13<br>_I | CROSS13_F | CROSS13[4:0] |  |     |
| 0x2<br>0E           | 0x<br>0E              | <a href="#">CROSS_14[7:<br/>:0]</a> | -   | CROSS14<br>_I | CROSS14_F | CROSS14[4:0] |  |     |
| 0x2<br>0F           | 0x<br>0F              | <a href="#">CROSS_15[7:<br/>:0]</a> | -   | CROSS15<br>_I | CROSS15_F | CROSS15[4:0] |  |     |
| 0x2<br>10           | 0x<br>10              | <a href="#">CROSS_16[7:<br/>:0]</a> | -   | CROSS16<br>_I | CROSS16_F | CROSS16[4:0] |  |     |
| 0x2<br>11           | 0x<br>11              | <a href="#">CROSS_17[7:<br/>:0]</a> | -   | CROSS17<br>_I | CROSS17_F | CROSS17[4:0] |  |     |
| 0x2<br>12           | 0x<br>12              | <a href="#">CROSS_18[7:<br/>:0]</a> | -   | CROSS18<br>_I | CROSS18_F | CROSS18[4:0] |  |     |
| 0x2<br>13           | 0x<br>13              | <a href="#">CROSS_19[7:<br/>:0]</a> | -   | CROSS19<br>_I | CROSS19_F | CROSS19[4:0] |  |     |
| 0x2<br>14           | 0x<br>14              | <a href="#">CROSS_20[7:<br/>:0]</a> | -   | CROSS20<br>_I | CROSS20_F | CROSS20[4:0] |  |     |

| AD<br>DR<br>ES<br>S | R<br>E<br>S<br>E<br>T | NAME                           | MSB                |            |                  |                  |        |        |               | LSB            |
|---------------------|-----------------------|--------------------------------|--------------------|------------|------------------|------------------|--------|--------|---------------|----------------|
| 0x2<br>15           | 0x<br>15              | <a href="#">CROSS_21[7:0]</a>  | -                  | CROSS21_I  | CROSS21_F        | CROSS21[4:0]     |        |        |               |                |
| 0x2<br>16           | 0x<br>16              | <a href="#">CROSS_22[7:0]</a>  | -                  | CROSS22_I  | CROSS22_F        | CROSS22[4:0]     |        |        |               |                |
| 0x2<br>17           | 0x<br>17              | <a href="#">CROSS_23[7:0]</a>  | -                  | CROSS23_I  | CROSS23_F        | CROSS23[4:0]     |        |        |               |                |
| 0x2<br>18           | 0x<br>18              | <a href="#">CROSS_HS[7:0]</a>  | -                  | CROSS_HS_I | CROSS_HS_F       | CROSS_HS[4:0]    |        |        |               |                |
| 0x2<br>19           | 0x<br>19              | <a href="#">CROSS_VS[7:0]</a>  | -                  | CROSS_VS_I | CROSS_VS_F       | CROSS_VS[4:0]    |        |        |               |                |
| 0x2<br>1A           | 0x<br>1A              | <a href="#">CROSS_DE[7:0]</a>  | -                  | CROSS_DE_I | CROSS_DE_F       | CROSS_DE[4:0]    |        |        |               |                |
| 0x2<br>1B           | 0x<br>00              | <a href="#">VPRBS_ERR[7:0]</a> | VPRBS_ERR[7:0]     |            |                  |                  |        |        |               |                |
| 0x2<br>1C           | 0x<br>80              | <a href="#">VPRBS[7:0]</a>     | PATGEN_C<br>LK_SRC | -          | VPRBS_FAIL       | VPRBS_CH<br>K_EN | -      | -      | -             | VIDEO_LO<br>CK |
| 0x2<br>1D           | 0x<br>1B              | <a href="#">CROSS_27[7:0]</a>  | ALT_CROS<br>SBAR   | CROSS27_I  | CROSS27_F        | CROSS27[4:0]     |        |        |               |                |
| 0x2<br>1E           | 0x<br>1C              | <a href="#">CROSS_28[7:0]</a>  | -                  | CROSS28_I  | CROSS28_F        | CROSS28[4:0]     |        |        |               |                |
| 0x2<br>1F           | 0x<br>1D              | <a href="#">CROSS_29[7:0]</a>  | -                  | CROSS29_I  | CROSS29_F        | CROSS29[4:0]     |        |        |               |                |
| <b>VRX_PATGEN_0</b> |                       |                                |                    |            |                  |                  |        |        |               |                |
| 0x2<br>40           | 0x<br>03              | <a href="#">PATGEN_0[7:0]</a>  | GEN_VS             | GEN_HS     | GEN_DE           | VS_INV           | HS_INV | DE_INV | VTG_MODE[1:0] |                |
| 0x2<br>41           | 0x<br>00              | <a href="#">PATGEN_1[7:0]</a>  | GRAD_MOD<br>E      | -          | PATGEN_MODE[1:0] |                  | -      | -      | -             | VS_TRIG        |
| 0x2<br>42           | 0x<br>00              | <a href="#">VS_DLY_2[7:0]</a>  | VS_DLY_2[7:0]      |            |                  |                  |        |        |               |                |
| 0x2<br>43           | 0x<br>00              | <a href="#">VS_DLY_1[7:0]</a>  | VS_DLY_1[7:0]      |            |                  |                  |        |        |               |                |

| AD<br>DR<br>ES<br>S | R<br>E<br>S<br>E<br>T | NAME                           | MSB |  |  |  |  |  |  | LSB            |
|---------------------|-----------------------|--------------------------------|-----|--|--|--|--|--|--|----------------|
| 0x2<br>44           | 0x<br>00              | <a href="#">VS_DLY_0[7:0]</a>  |     |  |  |  |  |  |  | VS_DLY_0[7:0]  |
| 0x2<br>45           | 0x<br>00              | <a href="#">VS_HIGH_2[7:0]</a> |     |  |  |  |  |  |  | VS_HIGH_2[7:0] |
| 0x2<br>46           | 0x<br>00              | <a href="#">VS_HIGH_1[7:0]</a> |     |  |  |  |  |  |  | VS_HIGH_1[7:0] |
| 0x2<br>47           | 0x<br>00              | <a href="#">VS_HIGH_0[7:0]</a> |     |  |  |  |  |  |  | VS_HIGH_0[7:0] |
| 0x2<br>48           | 0x<br>00              | <a href="#">VS_LOW_2[7:0]</a>  |     |  |  |  |  |  |  | VS_LOW_2[7:0]  |
| 0x2<br>49           | 0x<br>00              | <a href="#">VS_LOW_1[7:0]</a>  |     |  |  |  |  |  |  | VS_LOW_1[7:0]  |
| 0x2<br>4A           | 0x<br>00              | <a href="#">VS_LOW_0[7:0]</a>  |     |  |  |  |  |  |  | VS_LOW_0[7:0]  |
| 0x2<br>4B           | 0x<br>00              | <a href="#">V2H_2[7:0]</a>     |     |  |  |  |  |  |  | V2H_2[7:0]     |
| 0x2<br>4C           | 0x<br>00              | <a href="#">V2H_1[7:0]</a>     |     |  |  |  |  |  |  | V2H_1[7:0]     |
| 0x2<br>4D           | 0x<br>00              | <a href="#">V2H_0[7:0]</a>     |     |  |  |  |  |  |  | V2H_0[7:0]     |
| 0x2<br>4E           | 0x<br>00              | <a href="#">HS_HIGH_1[7:0]</a> |     |  |  |  |  |  |  | HS_HIGH_1[7:0] |
| 0x2<br>4F           | 0x<br>00              | <a href="#">HS_HIGH_0[7:0]</a> |     |  |  |  |  |  |  | HS_HIGH_0[7:0] |
| 0x2<br>50           | 0x<br>00              | <a href="#">HS_LOW_1[7:0]</a>  |     |  |  |  |  |  |  | HS_LOW_1[7:0]  |
| 0x2<br>51           | 0x<br>00              | <a href="#">HS_LOW_0[7:0]</a>  |     |  |  |  |  |  |  | HS_LOW_0[7:0]  |
| 0x2<br>52           | 0x<br>00              | <a href="#">HS_CNT_1[7:0]</a>  |     |  |  |  |  |  |  | HS_CNT_1[7:0]  |
| 0x2<br>53           | 0x<br>00              | <a href="#">HS_CNT_0[7:0]</a>  |     |  |  |  |  |  |  | HS_CNT_0[7:0]  |

| AD<br>DR<br>ES<br>S | R<br>E<br>S<br>E<br>T | NAME                                | MSB |  |  |  |  |  |  | LSB                 |
|---------------------|-----------------------|-------------------------------------|-----|--|--|--|--|--|--|---------------------|
| 0x2<br>54           | 0x<br>00              | <a href="#">V2D_2[7:0]</a>          |     |  |  |  |  |  |  | V2D_2[7:0]          |
| 0x2<br>55           | 0x<br>00              | <a href="#">V2D_1[7:0]</a>          |     |  |  |  |  |  |  | V2D_1[7:0]          |
| 0x2<br>56           | 0x<br>00              | <a href="#">V2D_0[7:0]</a>          |     |  |  |  |  |  |  | V2D_0[7:0]          |
| 0x2<br>57           | 0x<br>00              | <a href="#">DE_HIGH_1[7:0]</a>      |     |  |  |  |  |  |  | DE_HIGH_1[7:0]      |
| 0x2<br>58           | 0x<br>00              | <a href="#">DE_HIGH_0[7:0]</a>      |     |  |  |  |  |  |  | DE_HIGH_0[7:0]      |
| 0x2<br>59           | 0x<br>00              | <a href="#">DE_LOW_1[7:0]</a>       |     |  |  |  |  |  |  | DE_LOW_1[7:0]       |
| 0x2<br>5A           | 0x<br>00              | <a href="#">DE_LOW_0[7:0]</a>       |     |  |  |  |  |  |  | DE_LOW_0[7:0]       |
| 0x2<br>5B           | 0x<br>00              | <a href="#">DE_CNT_1[7:0]</a>       |     |  |  |  |  |  |  | DE_CNT_1[7:0]       |
| 0x2<br>5C           | 0x<br>00              | <a href="#">DE_CNT_0[7:0]</a>       |     |  |  |  |  |  |  | DE_CNT_0[7:0]       |
| 0x2<br>5D           | 0x<br>00              | <a href="#">GRAD_INCR[7:0]</a>      |     |  |  |  |  |  |  | GRAD_INCR[7:0]      |
| 0x2<br>5E           | 0x<br>00              | <a href="#">CHKR_COLOR_A_L[7:0]</a> |     |  |  |  |  |  |  | CHKR_COLOR_A_L[7:0] |
| 0x2<br>5F           | 0x<br>00              | <a href="#">CHKR_COLOR_A_M[7:0]</a> |     |  |  |  |  |  |  | CHKR_COLOR_A_M[7:0] |
| 0x2<br>60           | 0x<br>00              | <a href="#">CHKR_COLOR_A_H[7:0]</a> |     |  |  |  |  |  |  | CHKR_COLOR_A_H[7:0] |
| 0x2<br>61           | 0x<br>00              | <a href="#">CHKR_COLOR_B_L[7:0]</a> |     |  |  |  |  |  |  | CHKR_COLOR_B_L[7:0] |
| 0x2<br>62           | 0x<br>00              | <a href="#">CHKR_COLOR_B_M[7:0]</a> |     |  |  |  |  |  |  | CHKR_COLOR_B_M[7:0] |
| 0x2<br>63           | 0x<br>00              | <a href="#">CHKR_COLOR_B_H[7:0]</a> |     |  |  |  |  |  |  | CHKR_COLOR_B_H[7:0] |

| AD DR ES S     | R E S E T | NAME                            | MSB                |                 |                |                 |         |            |                | LSB              |
|----------------|-----------|---------------------------------|--------------------|-----------------|----------------|-----------------|---------|------------|----------------|------------------|
| 0x2<br>64      | 0x<br>00  | <a href="#">CHKR_RPT_A[7:0]</a> | CHKR_RPT_A[7:0]    |                 |                |                 |         |            |                |                  |
| 0x2<br>65      | 0x<br>00  | <a href="#">CHKR_RPT_B[7:0]</a> | CHKR_RPT_B[7:0]    |                 |                |                 |         |            |                |                  |
| 0x2<br>66      | 0x<br>00  | <a href="#">CHKR_ALT[7:0]</a>   | CHKR_ALT[7:0]      |                 |                |                 |         |            |                |                  |
| <b>GPIO0 0</b> |           |                                 |                    |                 |                |                 |         |            |                |                  |
| 0x2<br>B0      | 0x<br>83  | <a href="#">GPIO_A[7:0]</a>     | RES_CFG            | -               | TX_COMP_E<br>N | GPIO_OUT        | GPIO_IN | GPIO_RX_EN | GPIO_TX_E<br>N | GPIO_OUT<br>_DIS |
| 0x2<br>B1      | 0x<br>A0  | <a href="#">GPIO_B[7:0]</a>     | PULL_UPDN_SEL[1:0] |                 | OUT_TYPE       | GPIO_TX_ID[4:0] |         |            |                |                  |
| 0x2<br>B2      | 0x<br>40  | <a href="#">GPIO_C[7:0]</a>     | OVR_RES_<br>CFG    | GPIO_RE<br>CVED | -              | GPIO_RX_ID[4:0] |         |            |                |                  |
| <b>GPIO1 1</b> |           |                                 |                    |                 |                |                 |         |            |                |                  |
| 0x2<br>B3      | 0x<br>84  | <a href="#">GPIO_A[7:0]</a>     | RES_CFG            | -               | TX_COMP_E<br>N | GPIO_OUT        | GPIO_IN | GPIO_RX_EN | GPIO_TX_E<br>N | GPIO_OUT<br>_DIS |
| 0x2<br>B4      | 0x<br>A1  | <a href="#">GPIO_B[7:0]</a>     | PULL_UPDN_SEL[1:0] |                 | OUT_TYPE       | GPIO_TX_ID[4:0] |         |            |                |                  |
| 0x2<br>B5      | 0x<br>41  | <a href="#">GPIO_C[7:0]</a>     | OVR_RES_<br>CFG    | -               | -              | GPIO_RX_ID[4:0] |         |            |                |                  |
| <b>GPIO2 2</b> |           |                                 |                    |                 |                |                 |         |            |                |                  |
| 0x2<br>B6      | 0x<br>81  | <a href="#">GPIO_A[7:0]</a>     | RES_CFG            | -               | TX_COMP_E<br>N | GPIO_OUT        | GPIO_IN | GPIO_RX_EN | GPIO_TX_E<br>N | GPIO_OUT<br>_DIS |
| 0x2<br>B7      | 0x<br>22  | <a href="#">GPIO_B[7:0]</a>     | PULL_UPDN_SEL[1:0] |                 | OUT_TYPE       | GPIO_TX_ID[4:0] |         |            |                |                  |
| 0x2<br>B8      | 0x<br>42  | <a href="#">GPIO_C[7:0]</a>     | OVR_RES_<br>CFG    | -               | -              | GPIO_RX_ID[4:0] |         |            |                |                  |
| <b>GPIO3 3</b> |           |                                 |                    |                 |                |                 |         |            |                |                  |
| 0x2<br>B9      | 0x<br>81  | <a href="#">GPIO_A[7:0]</a>     | RES_CFG            | -               | TX_COMP_E<br>N | GPIO_OUT        | GPIO_IN | GPIO_RX_EN | GPIO_TX_E<br>N | GPIO_OUT<br>_DIS |

| AD DR ES S     | R E S E T | NAME                        | MSB                |   |            |                 |         |            |            | LSB          |
|----------------|-----------|-----------------------------|--------------------|---|------------|-----------------|---------|------------|------------|--------------|
| 0x2 BA         | 0x 23     | <a href="#">GPIO_B[7:0]</a> | PULL_UPDN_SEL[1:0] |   | OUT_TYPE   | GPIO_TX_ID[4:0] |         |            |            |              |
| 0x2 BB         | 0x 43     | <a href="#">GPIO_C[7:0]</a> | OVR_RES_CFG        | - | -          | GPIO_RX_ID[4:0] |         |            |            |              |
| <b>GPIO4 4</b> |           |                             |                    |   |            |                 |         |            |            |              |
| 0x2 BC         | 0x 81     | <a href="#">GPIO_A[7:0]</a> | RES_CFG            | - | TX_COMP_EN | GPIO_OUT        | GPIO_IN | GPIO_RX_EN | GPIO_TX_EN | GPIO_OUT_DIS |
| 0x2 BD         | 0x A4     | <a href="#">GPIO_B[7:0]</a> | PULL_UPDN_SEL[1:0] |   | OUT_TYPE   | GPIO_TX_ID[4:0] |         |            |            |              |
| 0x2 BE         | 0x 44     | <a href="#">GPIO_C[7:0]</a> | OVR_RES_CFG        | - | -          | GPIO_RX_ID[4:0] |         |            |            |              |
| <b>GPIO5 5</b> |           |                             |                    |   |            |                 |         |            |            |              |
| 0x2 BF         | 0x 84     | <a href="#">GPIO_A[7:0]</a> | RES_CFG            | - | TX_COMP_EN | GPIO_OUT        | GPIO_IN | GPIO_RX_EN | GPIO_TX_EN | GPIO_OUT_DIS |
| 0x2 C0         | 0x A5     | <a href="#">GPIO_B[7:0]</a> | PULL_UPDN_SEL[1:0] |   | OUT_TYPE   | GPIO_TX_ID[4:0] |         |            |            |              |
| 0x2 C1         | 0x 45     | <a href="#">GPIO_C[7:0]</a> | OVR_RES_CFG        | - | -          | GPIO_RX_ID[4:0] |         |            |            |              |
| <b>GPIO6 6</b> |           |                             |                    |   |            |                 |         |            |            |              |
| 0x2 C2         | 0x 83     | <a href="#">GPIO_A[7:0]</a> | RES_CFG            | - | TX_COMP_EN | GPIO_OUT        | GPIO_IN | GPIO_RX_EN | GPIO_TX_EN | GPIO_OUT_DIS |
| 0x2 C3         | 0x A6     | <a href="#">GPIO_B[7:0]</a> | PULL_UPDN_SEL[1:0] |   | OUT_TYPE   | GPIO_TX_ID[4:0] |         |            |            |              |
| 0x2 C4         | 0x 46     | <a href="#">GPIO_C[7:0]</a> | OVR_RES_CFG        | - | -          | GPIO_RX_ID[4:0] |         |            |            |              |
| <b>GPIO7 7</b> |           |                             |                    |   |            |                 |         |            |            |              |
| 0x2 C5         | 0x 81     | <a href="#">GPIO_A[7:0]</a> | RES_CFG            | - | TX_COMP_EN | GPIO_OUT        | GPIO_IN | GPIO_RX_EN | GPIO_TX_EN | GPIO_OUT_DIS |
| 0x2 C6         | 0x A7     | <a href="#">GPIO_B[7:0]</a> | PULL_UPDN_SEL[1:0] |   | OUT_TYPE   | GPIO_TX_ID[4:0] |         |            |            |              |

| AD DR ES S       | R E S E T    | NAME                        | MSB                |   |            |                 |         |            |            | LSB          |
|------------------|--------------|-----------------------------|--------------------|---|------------|-----------------|---------|------------|------------|--------------|
| 0x2<br>C7        | 0x<br>47     | <a href="#">GPIO C[7:0]</a> | OVR_RES_CFG        | - | -          | GPIO_RX_ID[4:0] |         |            |            |              |
| <b>GPIO8 8</b>   |              |                             |                    |   |            |                 |         |            |            |              |
| 0x2<br>C8        | 0x<br>81     | <a href="#">GPIO A[7:0]</a> | RES_CFG            | - | TX_COMP_EN | GPIO_OUT        | GPIO_IN | GPIO_RX_EN | GPIO_TX_EN | GPIO_OUT_DIS |
| 0x2<br>C9        | 0x<br>A8     | <a href="#">GPIO B[7:0]</a> | PULL_UPDN_SEL[1:0] |   | OUT_TYPE   | GPIO_TX_ID[4:0] |         |            |            |              |
| 0x2<br>CA        | 0x<br>48     | <a href="#">GPIO C[7:0]</a> | OVR_RES_CFG        | - | -          | GPIO_RX_ID[4:0] |         |            |            |              |
| <b>GPIO9 9</b>   |              |                             |                    |   |            |                 |         |            |            |              |
| 0x2<br>CB        | 0x<br>81     | <a href="#">GPIO A[7:0]</a> | RES_CFG            | - | TX_COMP_EN | GPIO_OUT        | GPIO_IN | GPIO_RX_EN | GPIO_TX_EN | GPIO_OUT_DIS |
| 0x2<br>CC        | 0x<br>A9     | <a href="#">GPIO B[7:0]</a> | PULL_UPDN_SEL[1:0] |   | OUT_TYPE   | GPIO_TX_ID[4:0] |         |            |            |              |
| 0x2<br>CD        | 0x<br>49     | <a href="#">GPIO C[7:0]</a> | OVR_RES_CFG        | - | -          | GPIO_RX_ID[4:0] |         |            |            |              |
| <b>GPIO10 10</b> |              |                             |                    |   |            |                 |         |            |            |              |
| 0x2<br>CE        | 0x<br>81     | <a href="#">GPIO A[7:0]</a> | RES_CFG            | - | TX_COMP_EN | GPIO_OUT        | GPIO_IN | GPIO_RX_EN | GPIO_TX_EN | GPIO_OUT_DIS |
| 0x2<br>CF        | 0x<br>A<br>A | <a href="#">GPIO B[7:0]</a> | PULL_UPDN_SEL[1:0] |   | OUT_TYPE   | GPIO_TX_ID[4:0] |         |            |            |              |
| 0x2<br>D0        | 0x<br>4A     | <a href="#">GPIO C[7:0]</a> | OVR_RES_CFG        | - | -          | GPIO_RX_ID[4:0] |         |            |            |              |
| <b>GPIO11 11</b> |              |                             |                    |   |            |                 |         |            |            |              |
| 0x2<br>D1        | 0x<br>81     | <a href="#">GPIO A[7:0]</a> | RES_CFG            | - | TX_COMP_EN | GPIO_OUT        | GPIO_IN | GPIO_RX_EN | GPIO_TX_EN | GPIO_OUT_DIS |
| 0x2<br>D2        | 0x<br>A<br>B | <a href="#">GPIO B[7:0]</a> | PULL_UPDN_SEL[1:0] |   | OUT_TYPE   | GPIO_TX_ID[4:0] |         |            |            |              |
| 0x2<br>D3        | 0x<br>4B     | <a href="#">GPIO C[7:0]</a> | OVR_RES_CFG        | - | -          | GPIO_RX_ID[4:0] |         |            |            |              |

| AD<br>DR<br>ES<br>S | R<br>E<br>S<br>E<br>T | NAME                           | MSB                |                    |                   |                  |                |            |                | LSB              |
|---------------------|-----------------------|--------------------------------|--------------------|--------------------|-------------------|------------------|----------------|------------|----------------|------------------|
| <b>GPIO12 12</b>    |                       |                                |                    |                    |                   |                  |                |            |                |                  |
| 0x2<br>D4           | 0x<br>81              | <a href="#">GPIO_A[7:0]</a>    | RES_CFG            | -                  | TX_COMP_E<br>N    | GPIO_OUT         | GPIO_IN        | GPIO_RX_EN | GPIO_TX_E<br>N | GPIO_OUT<br>_DIS |
| 0x2<br>D5           | 0x<br>A<br>C          | <a href="#">GPIO_B[7:0]</a>    | PULL_UPDN_SEL[1:0] |                    | OUT_TYPE          | GPIO_TX_ID[4:0]  |                |            |                |                  |
| 0x2<br>D6           | 0x<br>4<br>C          | <a href="#">GPIO_C[7:0]</a>    | OVR_RES_<br>CFG    | -                  | -                 | GPIO_RX_ID[4:0]  |                |            |                |                  |
| <b>CMU</b>          |                       |                                |                    |                    |                   |                  |                |            |                |                  |
| 0x3<br>02           | 0x<br>00              | <a href="#">CMU2[7:0]</a>      | -                  | PFDDIV_RSHORT[2:0] |                   |                  | -              | -          | -              | -                |
| <b>BACKTOP</b>      |                       |                                |                    |                    |                   |                  |                |            |                |                  |
| 0x3<br>08           | 0x<br>01              | <a href="#">BACKTOP1[7:0]</a>  | CSIPLLU_L<br>OCK   | CSIPLLZ_<br>LOCK   | CSIPLLY_LO<br>CK  | CSIPLLX_L<br>OCK | LINE_SPL<br>2  | -          | -              | BACKTOP_<br>EN   |
| 0x3<br>0B           | 0x<br>00              | <a href="#">BACKTOP4[7:0]</a>  | VS_VC2_L[7:0]      |                    |                   |                  |                |            |                |                  |
| 0x3<br>0C           | 0x<br>00              | <a href="#">BACKTOP5[7:0]</a>  | VS_VC2_H[7:0]      |                    |                   |                  |                |            |                |                  |
| 0x3<br>0D           | 0x<br>00              | <a href="#">BACKTOP6[7:0]</a>  | VS_VC3_L[7:0]      |                    |                   |                  |                |            |                |                  |
| 0x3<br>0E           | 0x<br>00              | <a href="#">BACKTOP7[7:0]</a>  | VS_VC3_H[7:0]      |                    |                   |                  |                |            |                |                  |
| 0x3<br>12           | 0x<br>00              | <a href="#">BACKTOP11[7:0]</a> | -                  | cmd_overfl<br>ow3  | cmd_overflow<br>2 | -                | -              | LMO_Z      | LMO_Y          | -                |
| 0x3<br>13           | 0x<br>02              | <a href="#">BACKTOP12[7:0]</a> | -                  | -                  | -                 | -                | -              | -          | CSI_OUT_E<br>N | -                |
| 0x3<br>14           | 0x<br>00              | <a href="#">BACKTOP13[7:0]</a> | soft_vc_y[3:0]     |                    |                   |                  | -              | -          | -              | -                |
| 0x3<br>15           | 0x<br>00              | <a href="#">BACKTOP14[7:0]</a> | -                  | -                  | -                 | -                | soft_vc_z[3:0] |            |                |                  |

| ADDRESS | RESET | NAME                            | MSB                                    |                     |  |                                   |  |   | LSB               |
|---------|-------|---------------------------------|--|---------------------|--|-----------------------------------|--|---|-------------------|
| 0x316   | 0x00  | <a href="#">BACKTOP15 [7:0]</a> | soft_dt_y_h[1:0]                       | -                   | -                                      | -                                 | -                                      | - | -                 |
| 0x317   | 0x00  | <a href="#">BACKTOP16 [7:0]</a> | soft_dt_z_h[3:0]                       |                     |  | soft_dt_y_l[3:0]                  |  |   |                   |
| 0x318   | 0x00  | <a href="#">BACKTOP17 [7:0]</a> | -                                      | -                   | -                                      | -                                 | -                                      | - | soft_dt_z_l[1:0]  |
| 0x319   | 0x00  | <a href="#">BACKTOP18 [7:0]</a> | soft_bpp_z_h[2:0]                      |                     |  | soft_bpp_y[4:0]                   |  |   |                   |
| 0x31A   | 0x00  | <a href="#">BACKTOP19 [7:0]</a> | -                                      | -                   | -                                      | -                                 | -                                      | - | soft_bpp_z_l[1:0] |
| 0x31B   | 0x00  | <a href="#">BACKTOP20 [7:0]</a> | phy0_csi_tx_dpll_fb_fraction_in_l[7:0] |                     |  |                                   |  |   |                   |
| 0x31C   | 0x00  | <a href="#">BACKTOP21 [7:0]</a> | -                                      | bpp8dblz            | bpp8dbly                               | -                                 | phy0_csi_tx_dpll_fb_fraction_in_h[3:0] |   |                   |
| 0x31D   | 0x2F  | <a href="#">BACKTOP22 [7:0]</a> | override_bpp_vc_dty                    | -                   | phy0_csi_tx_dpll_fb_fraction_predef_en | phy0_csi_tx_dpll_predef_freq[4:0] |  |   |                   |
| 0x31E   | 0x00  | <a href="#">BACKTOP23 [7:0]</a> | phy1_csi_tx_dpll_fb_fraction_in_l[7:0] |                     |  |                                   |  |   |                   |
| 0x31F   | 0x00  | <a href="#">BACKTOP24 [7:0]</a> | -                                      | bpp8dblz_mode       | bpp8dbly_mode                          | -                                 | phy1_csi_tx_dpll_fb_fraction_in_h[3:0] |   |                   |
| 0x320   | 0x2F  | <a href="#">BACKTOP25 [7:0]</a> | -                                      | override_bpp_vc_dtz | phy1_csi_tx_dpll_fb_fraction_predef_en | phy1_csi_tx_dpll_predef_freq[4:0] |  |   |                   |
| 0x321   | 0x00  | <a href="#">BACKTOP26 [7:0]</a> | phy2_csi_tx_dpll_fb_fraction_in_l[7:0] |                     |  |                                   |  |   |                   |
| 0x322   | 0x00  | <a href="#">BACKTOP27 [7:0]</a> | yuv_8_10_mux_mode4                     | yuv_8_10_mux_mode3  | yuv_8_10_mux_mode2                     | yuv_8_10_mux_mode1                | phy2_csi_tx_dpll_fb_fraction_in_h[3:0] |   |                   |
| 0x323   | 0x2F  | <a href="#">BACKTOP28 [7:0]</a> | -                                      | -                   | phy2_csi_tx_dpll_fb_fraction_predef_en | phy2_csi_tx_dpll_predef_freq[4:0] |  |   |                   |
| 0x324   | 0x00  | <a href="#">BACKTOP29 [7:0]</a> | phy3_csi_tx_dpll_fb_fraction_in_l[7:0] |                     |  |                                   |  |   |                   |

| ADDRESS         | REGISTER | NAME                             | MSB                |                |  |                                   |  |                 |                   | LSB               |
|-----------------|----------|----------------------------------|--------------------|----------------|--|-----------------------------------|--|-----------------|-------------------|-------------------|
| 0x325           | 0x00     | <a href="#">BACKTOP30 [7:0]</a>  | BACKTOP_W_FRAME    | -              | -                                      | -                                 | phy3_csi_tx_dpll_fb_fraction_in_h[3:0] |                 |                   |                   |
| 0x326           | 0x2F     | <a href="#">BACKTOP31 [7:0]</a>  | -                  | -              | phy3_csi_tx_dpll_fb_fraction_predef_en | phy3_csi_tx_dpll_predef_freq[4:0] |  |                 |                   |                   |
| 0x327           | 0x00     | <a href="#">BACKTOP32 [7:0]</a>  | -                  | bpp10dblz_mode | bpp10dbly_mode                         | -                                 | -                                      | bpp10dblz       | bpp10dbly         | -                 |
| 0x328           | 0x00     | <a href="#">BACKTOP33 [7:0]</a>  | -                  | -              | -                                      | -                                 | -                                      | bpp12dblz       | bpp12dbly         | -                 |
| <b>MIPI_PHY</b> |          |                                  |                    |                |  |                                   |  |                 |                   |                   |
| 0x330           | 0x04     | <a href="#">MIPI_PHY0 [7:0]</a>  | force_csi_out_en   | -              | -                                      | phy_1x4b_22                       | phy_1x4a_22                            | phy_2x4         | -                 | phy_4x2           |
| 0x331           | 0x00     | <a href="#">MIPI_PHY1 [7:0]</a>  | t_hs_przero[1:0]   |                | t_hs_prep[1:0]                         |                                   | -                                      | -               | t_clk_przero[1:0] |                   |
| 0x332           | 0xF4     | <a href="#">MIPI_PHY2 [7:0]</a>  | phy_Stdbyn[3:0]    |                |  | t_lpx[1:0]                        |  | t_hs_trail[1:0] |                   |                   |
| 0x333           | 0x4E     | <a href="#">MIPI_PHY3 [7:0]</a>  | phy1_lane_map[3:0] |                |  | phy0_lane_map[3:0]                |  |                 |                   |                   |
| 0x334           | 0xE4     | <a href="#">MIPI_PHY4 [7:0]</a>  | phy3_lane_map[3:0] |                |  | phy2_lane_map[3:0]                |  |                 |                   |                   |
| 0x335           | 0x00     | <a href="#">MIPI_PHY5 [7:0]</a>  | t_clk_prep[1:0]    |                | phy1_pol_map[2:0]                      |                                   | phy0_pol_map[2:0]                      |                 |                   |                   |
| 0x336           | 0x00     | <a href="#">MIPI_PHY6 [7:0]</a>  | phy_cp1            | phy_cp0        | phy3_pol_map[2:0]                      |                                   | phy2_pol_map[2:0]                      |                 |                   |                   |
| 0x339           | 0x00     | <a href="#">MIPI_PHY9 [7:0]</a>  | phy_cp0_dst[1:0]   |                | -                                      | -                                 | -                                      | -               | -                 | phy_cp0_overflow  |
| 0x33A           | 0x02     | <a href="#">MIPI_PHY10 [7:0]</a> | phy_cp0_src[1:0]   |                | -                                      | -                                 | -                                      | -               | -                 | phy_cp0_underflow |
| 0x33B           | 0x00     | <a href="#">MIPI_PHY11 [7:0]</a> | phy_cp1_dst[1:0]   |                | -                                      | -                                 | -                                      | -               | -                 | phy_cp1_overflow  |
| 0x33C           | 0x02     | <a href="#">MIPI_PHY12 [7:0]</a> | phy_cp1_src[1:0]   |                | -                                      | -                                 | -                                      | -               | -                 | phy_cp1_underflow |

| ADDRESS      | RESET | NAME                             | MSB                      |                          |                      |                          |                      |                          |                 | LSB               |
|--------------|-------|----------------------------------|--------------------------|--------------------------|----------------------|--------------------------|----------------------|--------------------------|-----------------|-------------------|
| 0x33D        | 0x00  | <a href="#">MIPI_PHY13[7:0]</a>  | -                        | -                        | t_t3_prebegin[5:0]   |                          |                      |                          |                 |                   |
| 0x33E        | 0x11  | <a href="#">MIPI_PHY14[7:0]</a>  | -                        | t_t3_post[4:0]           |                      |                          |                      |                          | t_t3_prep[1:0]  |                   |
| 0x33F        | 0x00  | <a href="#">MIPI_PHY15[7:0]</a>  | -                        | -                        | -                    | -                        | RST_MIPITX_LOC[3:0]  |                          |                 |                   |
| 0x340        | 0x00  | <a href="#">MIPI_PHY16[7:0]</a>  | -                        | -                        | TUN_DATA_CRC_ERR_OEN | TUN_ECC_UNCORR_ERR_OEN   | TUN_ECC_CORR_ERR_OEN | -                        | -               | VID_OVERFLOW_OEN  |
| 0x341        | 0x00  | <a href="#">MIPI_PHY17[7:0]</a>  | -                        | -                        | TUN_DATA_CRC_ERR     | TUN_ECC_UNCORR_ERR       | TUN_ECC_CORR_ERR     | -                        | -               | VID_OVERFLOW_FLAG |
| 0x342        | 0x00  | <a href="#">MIPI_PHY18[7:0]</a>  | csi2_tx2_pkt_cnt[3:0]    |                          |                      | csi2_tx1_pkt_cnt[3:0]    |                      |                          |                 |                   |
| 0x343        | 0x00  | <a href="#">MIPI_PHY19[7:0]</a>  | csi2_dup2_pkt_cnt[3:0]   |                          |                      | csi2_dup1_pkt_cnt[3:0]   |                      |                          |                 |                   |
| 0x344        | 0x00  | <a href="#">MIPI_PHY20[7:0]</a>  | phy1_pkt_cnt[3:0]        |                          |                      | phy0_pkt_cnt[3:0]        |                      |                          |                 |                   |
| 0x345        | 0x00  | <a href="#">MIPI_PHY21[7:0]</a>  | phy3_pkt_cnt[3:0]        |                          |                      | phy2_pkt_cnt[3:0]        |                      |                          |                 |                   |
| 0x350        | 0x00  | <a href="#">MIPI_PRBS_0[7:0]</a> | MIPI_PRBS_EN_P1_LN1[1:0] | MIPI_PRBS_EN_P1_LN0[1:0] |                      | MIPI_PRBS_EN_P0_LN1[1:0] |                      | MIPI_PRBS_EN_P0_LN0[1:0] |                 |                   |
| 0x351        | 0x00  | <a href="#">MIPI_PRBS_1[7:0]</a> | MIPI_PRBS_EN_P3_LN1[1:0] | MIPI_PRBS_EN_P3_LN0[1:0] |                      | MIPI_PRBS_EN_P2_LN1[1:0] |                      | MIPI_PRBS_EN_P2_LN0[1:0] |                 |                   |
| <b>FSYNC</b> |       |                                  |                          |                          |                      |                          |                      |                          |                 |                   |
| 0x3E0        | 0x0E  | <a href="#">FSYNC_0[7:0]</a>     | EN_OFLOW_RST_FS          | -                        | FSYNC_OUT_PIN        | EN_VS_GEN                | FSYNC_MODE[1:0]      |                          | FSYNC_METH[1:0] |                   |
| 0x3E1        | 0x00  | <a href="#">FSYNC_1[7:0]</a>     | -                        | -                        | -                    | -                        | FSYNC_PER_DIV[3:0]   |                          |                 |                   |
| 0x3E2        | 0x81  | <a href="#">FSYNC_2[7:0]</a>     | MST_LINK_SEL[2:0]        |                          |                      | K_VAL_SIG_N              | K_VAL[3:0]           |                          |                 |                   |
| 0x3E3        | 0x00  | <a href="#">FSYNC_3[7:0]</a>     | P_VAL_L[7:0]             |                          |                      |                          |                      |                          |                 |                   |

| AD<br>DR<br>ES<br>S | R<br>E<br>S<br>E<br>T | NAME                               | MSB                        |                  |                 |                         |                    |         |         | LSB |  |
|---------------------|-----------------------|------------------------------------|----------------------------|------------------|-----------------|-------------------------|--------------------|---------|---------|-----|--|
| 0x3<br>E4           | 0x<br>00              | <a href="#">FSYNC_4[7:<br/>0]</a>  | -                          | -                | P_VAL_SIGN      | P_VAL_H[4:0]            |                    |         |         |     |  |
| 0x3<br>E5           | 0x<br>00              | <a href="#">FSYNC_5[7:<br/>0]</a>  | FSYNC_PERIOD_L[7:0]        |                  |                 |                         |                    |         |         |     |  |
| 0x3<br>E6           | 0x<br>00              | <a href="#">FSYNC_6[7:<br/>0]</a>  | FSYNC_PERIOD_M[7:0]        |                  |                 |                         |                    |         |         |     |  |
| 0x3<br>E7           | 0x<br>00              | <a href="#">FSYNC_7[7:<br/>0]</a>  | FSYNC_PERIOD_H[7:0]        |                  |                 |                         |                    |         |         |     |  |
| 0x3<br>E8           | 0x<br>00              | <a href="#">FSYNC_8[7:<br/>0]</a>  | FRM_DIFF_ERR_THR_L[7:0]    |                  |                 |                         |                    |         |         |     |  |
| 0x3<br>E9           | 0x<br>0F              | <a href="#">FSYNC_9[7:<br/>0]</a>  | -                          | -                | -               | FRM_DIFF_ERR_THR_H[4:0] |                    |         |         |     |  |
| 0x3<br>EA           | 0x<br>00              | <a href="#">FSYNC_10[7<br/>:0]</a> | OVL_P_WINDOW_L[7:0]        |                  |                 |                         |                    |         |         |     |  |
| 0x3<br>EB           | 0x<br>00              | <a href="#">FSYNC_11[7<br/>:0]</a> | EN_FSIN_L<br>AST           | -                | -               | OVL_P_WINDOW_H[4:0]     |                    |         |         |     |  |
| 0x3<br>EF           | 0x<br>96              | <a href="#">FSYNC_15[7<br/>:0]</a> | FS_GPIO_T<br>YPE           | FS_USE_<br>XTAL  | -               | AUTO_FS_L<br>INKS       | -                  | FS_EN_Z | FS_EN_Y | -   |  |
| 0x3<br>F0           | 0x<br>00              | <a href="#">FSYNC_16[7<br/>:0]</a> | FSYNC_ERR_CNT[7:0]         |                  |                 |                         |                    |         |         |     |  |
| 0x3<br>F1           | 0x<br>F0              | <a href="#">FSYNC_17[7<br/>:0]</a> | FSYNC_TX_ID[4:0]           |                  |                 |                         | FSYNC_ERR_THR[2:0] |         |         |     |  |
| 0x3<br>F2           | 0x<br>00              | <a href="#">FSYNC_18[7<br/>:0]</a> | CALC_FRM_LEN_L[7:0]        |                  |                 |                         |                    |         |         |     |  |
| 0x3<br>F3           | 0x<br>00              | <a href="#">FSYNC_19[7<br/>:0]</a> | CALC_FRM_LEN_M[7:0]        |                  |                 |                         |                    |         |         |     |  |
| 0x3<br>F4           | 0x<br>00              | <a href="#">FSYNC_20[7<br/>:0]</a> | CALC_FRM_LEN_H[7:0]        |                  |                 |                         |                    |         |         |     |  |
| 0x3<br>F5           | 0x<br>00              | <a href="#">FSYNC_21[7<br/>:0]</a> | FRM_DIFF_L[7:0]            |                  |                 |                         |                    |         |         |     |  |
| 0x3<br>F6           | 0x<br>00              | <a href="#">FSYNC_22[7<br/>:0]</a> | FSYNC_LO<br>SS_OF_LO<br>CK | FSYNC_L<br>OCKED | FRM_DIFF_H[5:0] |                         |                    |         |         |     |  |

| ADDRESS          | RESET | NAME                           | MSB                |               |   |            |   |             |             | LSB |
|------------------|-------|--------------------------------|--------------------|---------------|---|------------|---|-------------|-------------|-----|
| 0x3F7            | 0x00  | <a href="#">FSYNC_23[7:0]</a>  | EN_SYNC_COMP       | EN_LINK_RESET | - | -          | - | FSYNC_OVR_Z | FSYNC_OVR_Y | -   |
| <b>MIPI_TX 0</b> |       |                                |                    |               |   |            |   |             |             |     |
| 0x40A            | 0x00  | <a href="#">MIPI_TX10[7:0]</a> | CSI2_LANE_CNT[1:0] | CSI2_CPHY_EN  | - | -          | - | -           | -           | -   |
| <b>MIPI_TX 1</b> |       |                                |                    |               |   |            |   |             |             |     |
| 0x441            | 0x00  | <a href="#">MIPI_TX1[7:0]</a>  | MODE[7:0]          |               |   |            |   |             |             |     |
| 0x442            | 0x00  | <a href="#">MIPI_TX2[7:0]</a>  | STATUS[7:0]        |               |   |            |   |             |             |     |
| 0x443            | 0x01  | <a href="#">MIPI_TX3[7:0]</a>  | DESKEW_INIT[7:0]   |               |   |            |   |             |             |     |
| 0x444            | 0x01  | <a href="#">MIPI_TX4[7:0]</a>  | DESKEW_PER[7:0]    |               |   |            |   |             |             |     |
| 0x447            | 0x1C  | <a href="#">MIPI_TX7[7:0]</a>  | CSI2_TX_GAP[7:0]   |               |   |            |   |             |             |     |
| 0x44A            | 0x00  | <a href="#">MIPI_TX10[7:0]</a> | CSI2_LANE_CNT[1:0] | CSI2_CPHY_EN  | - | CSI_VCX_EN | - | -           | -           | -   |
| 0x44B            | 0x00  | <a href="#">MIPI_TX11[7:0]</a> | MAP_EN_L[7:0]      |               |   |            |   |             |             |     |
| 0x44C            | 0x00  | <a href="#">MIPI_TX12[7:0]</a> | MAP_EN_H[7:0]      |               |   |            |   |             |             |     |
| 0x44D            | 0x00  | <a href="#">MIPI_TX13[7:0]</a> | MAP_SRC_0[7:0]     |               |   |            |   |             |             |     |
| 0x44E            | 0x00  | <a href="#">MIPI_TX14[7:0]</a> | MAP_DST_0[7:0]     |               |   |            |   |             |             |     |
| 0x44F            | 0x00  | <a href="#">MIPI_TX15[7:0]</a> | MAP_SRC_1[7:0]     |               |   |            |   |             |             |     |
| 0x450            | 0x00  | <a href="#">MIPI_TX16[7:0]</a> | MAP_DST_1[7:0]     |               |   |            |   |             |             |     |

| AD<br>DR<br>ES<br>S | R<br>E<br>S<br>E<br>T | NAME                           | MSB |  |  |  |  |  |  | LSB            |
|---------------------|-----------------------|--------------------------------|-----|--|--|--|--|--|--|----------------|
| 0x4<br>51           | 0x<br>00              | <a href="#">MIPI_TX17[7:0]</a> |     |  |  |  |  |  |  | MAP_SRC_2[7:0] |
| 0x4<br>52           | 0x<br>00              | <a href="#">MIPI_TX18[7:0]</a> |     |  |  |  |  |  |  | MAP_DST_2[7:0] |
| 0x4<br>53           | 0x<br>00              | <a href="#">MIPI_TX19[7:0]</a> |     |  |  |  |  |  |  | MAP_SRC_3[7:0] |
| 0x4<br>54           | 0x<br>00              | <a href="#">MIPI_TX20[7:0]</a> |     |  |  |  |  |  |  | MAP_DST_3[7:0] |
| 0x4<br>55           | 0x<br>00              | <a href="#">MIPI_TX21[7:0]</a> |     |  |  |  |  |  |  | MAP_SRC_4[7:0] |
| 0x4<br>56           | 0x<br>00              | <a href="#">MIPI_TX22[7:0]</a> |     |  |  |  |  |  |  | MAP_DST_4[7:0] |
| 0x4<br>57           | 0x<br>00              | <a href="#">MIPI_TX23[7:0]</a> |     |  |  |  |  |  |  | MAP_SRC_5[7:0] |
| 0x4<br>58           | 0x<br>00              | <a href="#">MIPI_TX24[7:0]</a> |     |  |  |  |  |  |  | MAP_DST_5[7:0] |
| 0x4<br>59           | 0x<br>00              | <a href="#">MIPI_TX25[7:0]</a> |     |  |  |  |  |  |  | MAP_SRC_6[7:0] |
| 0x4<br>5A           | 0x<br>00              | <a href="#">MIPI_TX26[7:0]</a> |     |  |  |  |  |  |  | MAP_DST_6[7:0] |
| 0x4<br>5B           | 0x<br>00              | <a href="#">MIPI_TX27[7:0]</a> |     |  |  |  |  |  |  | MAP_SRC_7[7:0] |
| 0x4<br>5C           | 0x<br>00              | <a href="#">MIPI_TX28[7:0]</a> |     |  |  |  |  |  |  | MAP_DST_7[7:0] |
| 0x4<br>5D           | 0x<br>00              | <a href="#">MIPI_TX29[7:0]</a> |     |  |  |  |  |  |  | MAP_SRC_8[7:0] |
| 0x4<br>5E           | 0x<br>00              | <a href="#">MIPI_TX30[7:0]</a> |     |  |  |  |  |  |  | MAP_DST_8[7:0] |
| 0x4<br>5F           | 0x<br>00              | <a href="#">MIPI_TX31[7:0]</a> |     |  |  |  |  |  |  | MAP_SRC_9[7:0] |
| 0x4<br>60           | 0x<br>00              | <a href="#">MIPI_TX32[7:0]</a> |     |  |  |  |  |  |  | MAP_DST_9[7:0] |

| AD<br>DR<br>ES<br>S | R<br>E<br>S<br>E<br>T | NAME                           | MSB                   |                       |                       |                       |  |  |  | LSB |
|---------------------|-----------------------|--------------------------------|-----------------------|-----------------------|-----------------------|-----------------------|--|--|--|-----|
| 0x4<br>61           | 0x<br>00              | <a href="#">MIPI_TX33[7:0]</a> | MAP_SRC_10[7:0]       |                       |                       |                       |  |  |  |     |
| 0x4<br>62           | 0x<br>00              | <a href="#">MIPI_TX34[7:0]</a> | MAP_DST_10[7:0]       |                       |                       |                       |  |  |  |     |
| 0x4<br>63           | 0x<br>00              | <a href="#">MIPI_TX35[7:0]</a> | MAP_SRC_11[7:0]       |                       |                       |                       |  |  |  |     |
| 0x4<br>64           | 0x<br>00              | <a href="#">MIPI_TX36[7:0]</a> | MAP_DST_11[7:0]       |                       |                       |                       |  |  |  |     |
| 0x4<br>65           | 0x<br>00              | <a href="#">MIPI_TX37[7:0]</a> | MAP_SRC_12[7:0]       |                       |                       |                       |  |  |  |     |
| 0x4<br>66           | 0x<br>00              | <a href="#">MIPI_TX38[7:0]</a> | MAP_DST_12[7:0]       |                       |                       |                       |  |  |  |     |
| 0x4<br>67           | 0x<br>00              | <a href="#">MIPI_TX39[7:0]</a> | MAP_SRC_13[7:0]       |                       |                       |                       |  |  |  |     |
| 0x4<br>68           | 0x<br>00              | <a href="#">MIPI_TX40[7:0]</a> | MAP_DST_13[7:0]       |                       |                       |                       |  |  |  |     |
| 0x4<br>69           | 0x<br>00              | <a href="#">MIPI_TX41[7:0]</a> | MAP_SRC_14[7:0]       |                       |                       |                       |  |  |  |     |
| 0x4<br>6A           | 0x<br>00              | <a href="#">MIPI_TX42[7:0]</a> | MAP_DST_14[7:0]       |                       |                       |                       |  |  |  |     |
| 0x4<br>6B           | 0x<br>00              | <a href="#">MIPI_TX43[7:0]</a> | MAP_SRC_15[7:0]       |                       |                       |                       |  |  |  |     |
| 0x4<br>6C           | 0x<br>00              | <a href="#">MIPI_TX44[7:0]</a> | MAP_DST_15[7:0]       |                       |                       |                       |  |  |  |     |
| 0x4<br>6D           | 0x<br>00              | <a href="#">MIPI_TX45[7:0]</a> | MAP_DPHY_DEST_3[1:0]  | MAP_DPHY_DEST_2[1:0]  | MAP_DPHY_DEST_1[1:0]  | MAP_DPHY_DEST_0[1:0]  |  |  |  |     |
| 0x4<br>6E           | 0x<br>00              | <a href="#">MIPI_TX46[7:0]</a> | MAP_DPHY_DEST_7[1:0]  | MAP_DPHY_DEST_6[1:0]  | MAP_DPHY_DEST_5[1:0]  | MAP_DPHY_DEST_4[1:0]  |  |  |  |     |
| 0x4<br>6F           | 0x<br>00              | <a href="#">MIPI_TX47[7:0]</a> | MAP_DPHY_DEST_11[1:0] | MAP_DPHY_DEST_10[1:0] | MAP_DPHY_DEST_9[1:0]  | MAP_DPHY_DEST_8[1:0]  |  |  |  |     |
| 0x4<br>70           | 0x<br>00              | <a href="#">MIPI_TX48[7:0]</a> | MAP_DPHY_DEST_15[1:0] | MAP_DPHY_DEST_14[1:0] | MAP_DPHY_DEST_13[1:0] | MAP_DPHY_DEST_12[1:0] |  |  |  |     |

| ADDRESS          | RESET | NAME                           | MSB                     |                 |                       |                |              |               | LSB                |  |
|------------------|-------|--------------------------------|-------------------------|-----------------|-----------------------|----------------|--------------|---------------|--------------------|--|
| 0x472            | 0x00  | <a href="#">MIPI_TX50[7:0]</a> | SKEW_PER_SEL[7:0]       |                 |                       |                |              |               |                    |  |
| 0x473            | 0x00  | <a href="#">MIPI_TX51[7:0]</a> | TUN_WAIT_VS_START[2:0]  | ALT2_MEM_MAP8   | MODE_DT               | ALT_MEM_MAP10  | ALT_MEM_MAP8 | ALT_MEM_MAP12 |                    |  |
| 0x474            | 0x08  | <a href="#">MIPI_TX52[7:0]</a> | TUN_NO_CORR             | DESKEW_TUN[1:0] | TUN_SER_LANE_NUM[1:0] | DESKEW_TUN_SRC | TUN_DEST     | TUN_EN        |                    |  |
| 0x475            | 0x00  | <a href="#">MIPI_TX53[7:0]</a> | DESKEW_TUN_OFFSET[7:0]  |                 |                       |                |              |               |                    |  |
| 0x476            | 0x00  | <a href="#">MIPI_TX54[7:0]</a> | TUN_PKT_START_ADDR[7:0] |                 |                       |                |              |               |                    |  |
| 0x477            | 0x00  | <a href="#">MIPI_TX55[7:0]</a> | -                       | -               | -                     | -              | -            | -             | TUN_NO_CORR_LENGTH |  |
| <b>MIPI_TX 2</b> |       |                                |                         |                 |                       |                |              |               |                    |  |
| 0x481            | 0x00  | <a href="#">MIPI_TX1[7:0]</a>  | MODE[7:0]               |                 |                       |                |              |               |                    |  |
| 0x482            | 0x00  | <a href="#">MIPI_TX2[7:0]</a>  | STATUS[7:0]             |                 |                       |                |              |               |                    |  |
| 0x483            | 0x01  | <a href="#">MIPI_TX3[7:0]</a>  | DESKEW_INIT[7:0]        |                 |                       |                |              |               |                    |  |
| 0x484            | 0x01  | <a href="#">MIPI_TX4[7:0]</a>  | DESKEW_PER[7:0]         |                 |                       |                |              |               |                    |  |
| 0x487            | 0x1C  | <a href="#">MIPI_TX7[7:0]</a>  | CSI2_TX_GAP[7:0]        |                 |                       |                |              |               |                    |  |
| 0x48A            | 0x00  | <a href="#">MIPI_TX10[7:0]</a> | CSI2_LANE_CNT[1:0]      | CSI2_CPHY_EN    | -                     | CSI_VCX_EN     | -            | -             | -                  |  |
| 0x48B            | 0x00  | <a href="#">MIPI_TX11[7:0]</a> | MAP_EN_L[7:0]           |                 |                       |                |              |               |                    |  |
| 0x48C            | 0x00  | <a href="#">MIPI_TX12[7:0]</a> | MAP_EN_H[7:0]           |                 |                       |                |              |               |                    |  |

| AD<br>DR<br>ES<br>S | R<br>E<br>S<br>E<br>T | NAME                           | MSB |  |  |  |  |  |  | LSB            |
|---------------------|-----------------------|--------------------------------|-----|--|--|--|--|--|--|----------------|
| 0x4<br>8D           | 0x<br>00              | <a href="#">MIPI_TX13[7:0]</a> |     |  |  |  |  |  |  | MAP_SRC_0[7:0] |
| 0x4<br>8E           | 0x<br>00              | <a href="#">MIPI_TX14[7:0]</a> |     |  |  |  |  |  |  | MAP_DST_0[7:0] |
| 0x4<br>8F           | 0x<br>00              | <a href="#">MIPI_TX15[7:0]</a> |     |  |  |  |  |  |  | MAP_SRC_1[7:0] |
| 0x4<br>90           | 0x<br>00              | <a href="#">MIPI_TX16[7:0]</a> |     |  |  |  |  |  |  | MAP_DST_1[7:0] |
| 0x4<br>91           | 0x<br>00              | <a href="#">MIPI_TX17[7:0]</a> |     |  |  |  |  |  |  | MAP_SRC_2[7:0] |
| 0x4<br>92           | 0x<br>00              | <a href="#">MIPI_TX18[7:0]</a> |     |  |  |  |  |  |  | MAP_DST_2[7:0] |
| 0x4<br>93           | 0x<br>00              | <a href="#">MIPI_TX19[7:0]</a> |     |  |  |  |  |  |  | MAP_SRC_3[7:0] |
| 0x4<br>94           | 0x<br>00              | <a href="#">MIPI_TX20[7:0]</a> |     |  |  |  |  |  |  | MAP_DST_3[7:0] |
| 0x4<br>95           | 0x<br>00              | <a href="#">MIPI_TX21[7:0]</a> |     |  |  |  |  |  |  | MAP_SRC_4[7:0] |
| 0x4<br>96           | 0x<br>00              | <a href="#">MIPI_TX22[7:0]</a> |     |  |  |  |  |  |  | MAP_DST_4[7:0] |
| 0x4<br>97           | 0x<br>00              | <a href="#">MIPI_TX23[7:0]</a> |     |  |  |  |  |  |  | MAP_SRC_5[7:0] |
| 0x4<br>98           | 0x<br>00              | <a href="#">MIPI_TX24[7:0]</a> |     |  |  |  |  |  |  | MAP_DST_5[7:0] |
| 0x4<br>99           | 0x<br>00              | <a href="#">MIPI_TX25[7:0]</a> |     |  |  |  |  |  |  | MAP_SRC_6[7:0] |
| 0x4<br>9A           | 0x<br>00              | <a href="#">MIPI_TX26[7:0]</a> |     |  |  |  |  |  |  | MAP_DST_6[7:0] |
| 0x4<br>9B           | 0x<br>00              | <a href="#">MIPI_TX27[7:0]</a> |     |  |  |  |  |  |  | MAP_SRC_7[7:0] |
| 0x4<br>9C           | 0x<br>00              | <a href="#">MIPI_TX28[7:0]</a> |     |  |  |  |  |  |  | MAP_DST_7[7:0] |

| AD<br>DR<br>ES<br>S | R<br>E<br>S<br>E<br>T | NAME                           | MSB |  |  |  |  |  |  | LSB             |
|---------------------|-----------------------|--------------------------------|-----|--|--|--|--|--|--|-----------------|
| 0x4<br>9D           | 0x<br>00              | <a href="#">MIPI_TX29[7:0]</a> |     |  |  |  |  |  |  | MAP_SRC_8[7:0]  |
| 0x4<br>9E           | 0x<br>00              | <a href="#">MIPI_TX30[7:0]</a> |     |  |  |  |  |  |  | MAP_DST_8[7:0]  |
| 0x4<br>9F           | 0x<br>00              | <a href="#">MIPI_TX31[7:0]</a> |     |  |  |  |  |  |  | MAP_SRC_9[7:0]  |
| 0x4<br>A0           | 0x<br>00              | <a href="#">MIPI_TX32[7:0]</a> |     |  |  |  |  |  |  | MAP_DST_9[7:0]  |
| 0x4<br>A1           | 0x<br>00              | <a href="#">MIPI_TX33[7:0]</a> |     |  |  |  |  |  |  | MAP_SRC_10[7:0] |
| 0x4<br>A2           | 0x<br>00              | <a href="#">MIPI_TX34[7:0]</a> |     |  |  |  |  |  |  | MAP_DST_10[7:0] |
| 0x4<br>A3           | 0x<br>00              | <a href="#">MIPI_TX35[7:0]</a> |     |  |  |  |  |  |  | MAP_SRC_11[7:0] |
| 0x4<br>A4           | 0x<br>00              | <a href="#">MIPI_TX36[7:0]</a> |     |  |  |  |  |  |  | MAP_DST_11[7:0] |
| 0x4<br>A5           | 0x<br>00              | <a href="#">MIPI_TX37[7:0]</a> |     |  |  |  |  |  |  | MAP_SRC_12[7:0] |
| 0x4<br>A6           | 0x<br>00              | <a href="#">MIPI_TX38[7:0]</a> |     |  |  |  |  |  |  | MAP_DST_12[7:0] |
| 0x4<br>A7           | 0x<br>00              | <a href="#">MIPI_TX39[7:0]</a> |     |  |  |  |  |  |  | MAP_SRC_13[7:0] |
| 0x4<br>A8           | 0x<br>00              | <a href="#">MIPI_TX40[7:0]</a> |     |  |  |  |  |  |  | MAP_DST_13[7:0] |
| 0x4<br>A9           | 0x<br>00              | <a href="#">MIPI_TX41[7:0]</a> |     |  |  |  |  |  |  | MAP_SRC_14[7:0] |
| 0x4<br>AA           | 0x<br>00              | <a href="#">MIPI_TX42[7:0]</a> |     |  |  |  |  |  |  | MAP_DST_14[7:0] |
| 0x4<br>AB           | 0x<br>00              | <a href="#">MIPI_TX43[7:0]</a> |     |  |  |  |  |  |  | MAP_SRC_15[7:0] |
| 0x4<br>AC           | 0x<br>00              | <a href="#">MIPI_TX44[7:0]</a> |     |  |  |  |  |  |  | MAP_DST_15[7:0] |

| ADDRESS              | RESET | NAME                              | MSB                     |                 |                       |                |                       |              | LSB                   |
|----------------------|-------|-----------------------------------|-------------------------|-----------------|-----------------------|----------------|-----------------------|--------------|-----------------------|
| 0x4AD                | 0x00  | <a href="#">MIPI_TX45[7:0]</a>    | MAP_DPHY_DEST_3[1:0]    |                 | MAP_DPHY_DEST_2[1:0]  |                | MAP_DPHY_DEST_1[1:0]  |              | MAP_DPHY_DEST_0[1:0]  |
| 0x4AE                | 0x00  | <a href="#">MIPI_TX46[7:0]</a>    | MAP_DPHY_DEST_7[1:0]    |                 | MAP_DPHY_DEST_6[1:0]  |                | MAP_DPHY_DEST_5[1:0]  |              | MAP_DPHY_DEST_4[1:0]  |
| 0x4AF                | 0x00  | <a href="#">MIPI_TX47[7:0]</a>    | MAP_DPHY_DEST_11[1:0]   |                 | MAP_DPHY_DEST_10[1:0] |                | MAP_DPHY_DEST_9[1:0]  |              | MAP_DPHY_DEST_8[1:0]  |
| 0x4B0                | 0x00  | <a href="#">MIPI_TX48[7:0]</a>    | MAP_DPHY_DEST_15[1:0]   |                 | MAP_DPHY_DEST_14[1:0] |                | MAP_DPHY_DEST_13[1:0] |              | MAP_DPHY_DEST_12[1:0] |
| 0x4B2                | 0x00  | <a href="#">MIPI_TX50[7:0]</a>    | SKEW_PER_SEL[7:0]       |                 |                       |                |                       |              |                       |
| 0x4B3                | 0x00  | <a href="#">MIPI_TX51[7:0]</a>    | TUN_WAIT_VS_START[2:0]  |                 | ALT2_MEM_MAP8         | MODE_DT        | ALT_MEM_MAP10         | ALT_MEM_MAP8 | ALT_MEM_MAP12         |
| 0x4B4                | 0x0E  | <a href="#">MIPI_TX52[7:0]</a>    | TUN_NO_CORR             | DESKEW_TUN[1:0] | TUN_SER_LANE_NUM[1:0] | DESKEW_TUN_SRC | TUN_DEST              | TUN_EN       |                       |
| 0x4B5                | 0x00  | <a href="#">MIPI_TX53[7:0]</a>    | DESKEW_TUN_OFFSET[7:0]  |                 |                       |                |                       |              |                       |
| 0x4B6                | 0x00  | <a href="#">MIPI_TX54[7:0]</a>    | TUN_PKT_START_ADDR[7:0] |                 |                       |                |                       |              |                       |
| 0x4B7                | 0x00  | <a href="#">MIPI_TX55[7:0]</a>    | -                       | -               | -                     | -              | -                     | -            | TUN_NO_CORR_LENGTH    |
| <b>MIPI_TX 3</b>     |       |                                   |                         |                 |                       |                |                       |              |                       |
| 0x4CA0               | 0x00  | <a href="#">MIPI_TX10[7:0]</a>    | CSI2_LANE_CNT[1:0]      | CSI2_CPHY_EN    | -                     | -              | -                     | -            | -                     |
| <b>MIPI_TX_EXT 1</b> |       |                                   |                         |                 |                       |                |                       |              |                       |
| 0x510                | 0x00  | <a href="#">MIPI_TX_EXT0[7:0]</a> | MAP_SRC_0_H[2:0]        |                 | MAP_DST_0_H[2:0]      |                | -                     |              | -                     |
| 0x511                | 0x00  | <a href="#">MIPI_TX_EXT1[7:0]</a> | MAP_SRC_1_H[2:0]        |                 | MAP_DST_1_H[2:0]      |                | -                     |              | -                     |
| 0x512                | 0x00  | <a href="#">MIPI_TX_EXT2[7:0]</a> | MAP_SRC_2_H[2:0]        |                 | MAP_DST_2_H[2:0]      |                | -                     |              | -                     |

| AD<br>DR<br>ES<br>S  | R<br>E<br>S<br>E<br>T | NAME                                    | MSB               |  |  |  |                   |   | LSB |
|----------------------|-----------------------|---|-------------------|--|--|--|-------------------|---|-----|
| 0x5<br>13            | 0x<br>00              | <a href="#">MIPI_TX_EX<br/>T3[7:0]</a>  | MAP_SRC_3_H[2:0]  |  |  |  | MAP_DST_3_H[2:0]  | - | -   |
| 0x5<br>14            | 0x<br>00              | <a href="#">MIPI_TX_EX<br/>T4[7:0]</a>  | MAP_SRC_4_H[2:0]  |  |  |  | MAP_DST_4_H[2:0]  | - | -   |
| 0x5<br>15            | 0x<br>00              | <a href="#">MIPI_TX_EX<br/>T5[7:0]</a>  | MAP_SRC_5_H[2:0]  |  |  |  | MAP_DST_5_H[2:0]  | - | -   |
| 0x5<br>16            | 0x<br>00              | <a href="#">MIPI_TX_EX<br/>T6[7:0]</a>  | MAP_SRC_6_H[2:0]  |  |  |  | MAP_DST_6_H[2:0]  | - | -   |
| 0x5<br>17            | 0x<br>00              | <a href="#">MIPI_TX_EX<br/>T7[7:0]</a>  | MAP_SRC_7_H[2:0]  |  |  |  | MAP_DST_7_H[2:0]  | - | -   |
| 0x5<br>18            | 0x<br>00              | <a href="#">MIPI_TX_EX<br/>T8[7:0]</a>  | MAP_SRC_8_H[2:0]  |  |  |  | MAP_DST_8_H[2:0]  | - | -   |
| 0x5<br>19            | 0x<br>00              | <a href="#">MIPI_TX_EX<br/>T9[7:0]</a>  | MAP_SRC_9_H[2:0]  |  |  |  | MAP_DST_9_H[2:0]  | - | -   |
| 0x5<br>1A            | 0x<br>00              | <a href="#">MIPI_TX_EX<br/>T10[7:0]</a> | MAP_SRC_10_H[2:0] |  |  |  | MAP_DST_10_H[2:0] | - | -   |
| 0x5<br>1B            | 0x<br>00              | <a href="#">MIPI_TX_EX<br/>T11[7:0]</a> | MAP_SRC_11_H[2:0] |  |  |  | MAP_DST_11_H[2:0] | - | -   |
| 0x5<br>1C            | 0x<br>00              | <a href="#">MIPI_TX_EX<br/>T12[7:0]</a> | MAP_SRC_12_H[2:0] |  |  |  | MAP_DST_12_H[2:0] | - | -   |
| 0x5<br>1D            | 0x<br>00              | <a href="#">MIPI_TX_EX<br/>T13[7:0]</a> | MAP_SRC_13_H[2:0] |  |  |  | MAP_DST_13_H[2:0] | - | -   |
| 0x5<br>1E            | 0x<br>00              | <a href="#">MIPI_TX_EX<br/>T14[7:0]</a> | MAP_SRC_14_H[2:0] |  |  |  | MAP_DST_14_H[2:0] | - | -   |
| 0x5<br>1F            | 0x<br>00              | <a href="#">MIPI_TX_EX<br/>T15[7:0]</a> | MAP_SRC_15_H[2:0] |  |  |  | MAP_DST_15_H[2:0] | - | -   |
| <b>MIPI_TX_EXT 2</b> |                       |   |                   |  |  |  |                   |   |     |
| 0x5<br>20            | 0x<br>00              | <a href="#">MIPI_TX_EX<br/>T0[7:0]</a>  | MAP_SRC_0_H[2:0]  |  |  |  | MAP_DST_0_H[2:0]  | - | -   |
| 0x5<br>21            | 0x<br>00              | <a href="#">MIPI_TX_EX<br/>T1[7:0]</a>  | MAP_SRC_1_H[2:0]  |  |  |  | MAP_DST_1_H[2:0]  | - | -   |

| AD<br>DR<br>ES<br>S | R<br>E<br>S<br>E<br>T | NAME                                    | MSB               |  |  |   |                   |   | LSB |
|---------------------|-----------------------|---|-------------------|--|--|---|-------------------|---|-----|
| 0x5<br>22           | 0x<br>00              | <a href="#">MIPI_TX_EX<br/>T2[7:0]</a>  | MAP_SRC_2_H[2:0]  |  |  |   | MAP_DST_2_H[2:0]  | - | -   |
| 0x5<br>23           | 0x<br>00              | <a href="#">MIPI_TX_EX<br/>T3[7:0]</a>  | MAP_SRC_3_H[2:0]  |  |  |   | MAP_DST_3_H[2:0]  | - | -   |
| 0x5<br>24           | 0x<br>00              | <a href="#">MIPI_TX_EX<br/>T4[7:0]</a>  | MAP_SRC_4_H[2:0]  |  |  |   | MAP_DST_4_H[2:0]  | - | -   |
| 0x5<br>25           | 0x<br>00              | <a href="#">MIPI_TX_EX<br/>T5[7:0]</a>  | MAP_SRC_5_H[2:0]  |  |  |   | MAP_DST_5_H[2:0]  | - | -   |
| 0x5<br>26           | 0x<br>00              | <a href="#">MIPI_TX_EX<br/>T6[7:0]</a>  | MAP_SRC_6_H[2:0]  |  |  |   | MAP_DST_6_H[2:0]  | - | -   |
| 0x5<br>27           | 0x<br>00              | <a href="#">MIPI_TX_EX<br/>T7[7:0]</a>  | MAP_SRC_7_H[2:0]  |  |  |   | MAP_DST_7_H[2:0]  | - | -   |
| 0x5<br>28           | 0x<br>00              | <a href="#">MIPI_TX_EX<br/>T8[7:0]</a>  | MAP_SRC_8_H[2:0]  |  |  |   | MAP_DST_8_H[2:0]  | - | -   |
| 0x5<br>29           | 0x<br>00              | <a href="#">MIPI_TX_EX<br/>T9[7:0]</a>  | MAP_SRC_9_H[2:0]  |  |  |   | MAP_DST_9_H[2:0]  | - | -   |
| 0x5<br>2A           | 0x<br>00              | <a href="#">MIPI_TX_EX<br/>T10[7:0]</a> | MAP_SRC_10_H[2:0] |  |  |   | MAP_DST_10_H[2:0] | - | -   |
| 0x5<br>2B           | 0x<br>00              | <a href="#">MIPI_TX_EX<br/>T11[7:0]</a> | MAP_SRC_11_H[2:0] |  |  |   | MAP_DST_11_H[2:0] | - | -   |
| 0x5<br>2C           | 0x<br>00              | <a href="#">MIPI_TX_EX<br/>T12[7:0]</a> | MAP_SRC_12_H[2:0] |  |  |   | MAP_DST_12_H[2:0] | - | -   |
| 0x5<br>2D           | 0x<br>00              | <a href="#">MIPI_TX_EX<br/>T13[7:0]</a> | MAP_SRC_13_H[2:0] |  |  |   | MAP_DST_13_H[2:0] | - | -   |
| 0x5<br>2E           | 0x<br>00              | <a href="#">MIPI_TX_EX<br/>T14[7:0]</a> | MAP_SRC_14_H[2:0] |  |  |   | MAP_DST_14_H[2:0] | - | -   |
| 0x5<br>2F           | 0x<br>00              | <a href="#">MIPI_TX_EX<br/>T15[7:0]</a> | MAP_SRC_15_H[2:0] |  |  |   | MAP_DST_15_H[2:0] | - | -   |
| <b>MISC</b>         |                       |   |                   |  |  |   |                   |   |     |
| 0x5<br>40           | 0x<br>00              | <a href="#">CFG_0[7:0]</a>              | VS_OUT1[2:0]      |  |  | - | -                 | - | -   |

| AD<br>DR<br>ES<br>S | R<br>E<br>S<br>E<br>T | NAME                           | MSB |              |  |   |   |   | LSB |
|---------------------|-----------------------|--------------------------------|-----|--------------|--|---|---|---|-----|
| 0x5<br>41           | 0x<br>00              | <a href="#">CFG 1[7:0]</a>     |     |              |  |   |   |   |     |
|                     |                       |                                |     | VS_OUT2[2:0] |  | - | - | - | -   |
| 0x5<br>42           | 0x<br>00              | <a href="#">CFG 2[7:0]</a>     |     |              |  |   |   |   |     |
|                     |                       |                                |     | HS_OUT1[2:0] |  | - | - | - | -   |
| 0x5<br>48           | 0x<br>96              | <a href="#">UART_PT_0[7:0]</a> |     |              |  |   |   |   |     |
|                     |                       |                                |     |              |  |   |   |   |     |
| 0x5<br>49           | 0x<br>00              | <a href="#">UART_PT_1[7:0]</a> | -   | -            |  |   |   |   |     |
|                     |                       |                                |     |              |  |   |   |   |     |
| 0x5<br>4A           | 0x<br>96              | <a href="#">UART_PT_2[7:0]</a> |     |              |  |   |   |   |     |
|                     |                       |                                |     |              |  |   |   |   |     |
| 0x5<br>4B           | 0x<br>00              | <a href="#">UART_PT_3[7:0]</a> | -   | -            |  |   |   |   |     |
|                     |                       |                                |     |              |  |   |   |   |     |
| 0x5<br>50           | 0x<br>00              | <a href="#">I2C_PT_4[7:0]</a>  |     |              |  |   |   |   |     |
|                     |                       |                                |     |              |  |   |   |   |     |
| 0x5<br>51           | 0x<br>00              | <a href="#">I2C_PT_5[7:0]</a>  |     |              |  |   |   |   |     |
|                     |                       |                                |     |              |  |   |   |   |     |
| 0x5<br>52           | 0x<br>00              | <a href="#">I2C_PT_6[7:0]</a>  |     |              |  |   |   |   |     |
|                     |                       |                                |     |              |  |   |   |   |     |
| 0x5<br>53           | 0x<br>00              | <a href="#">I2C_PT_7[7:0]</a>  |     |              |  |   |   |   |     |
|                     |                       |                                |     |              |  |   |   |   |     |
| 0x5<br>54           | 0x<br>00              | <a href="#">I2C_PT_8[7:0]</a>  |     |              |  |   |   |   |     |
|                     |                       |                                |     |              |  |   |   |   |     |
| 0x5<br>55           | 0x<br>00              | <a href="#">I2C_PT_9[7:0]</a>  |     |              |  |   |   |   |     |
|                     |                       |                                |     |              |  |   |   |   |     |
| 0x5<br>56           | 0x<br>00              | <a href="#">I2C_PT_10[7:0]</a> |     |              |  |   |   |   |     |
|                     |                       |                                |     |              |  |   |   |   |     |
| 0x5<br>57           | 0x<br>00              | <a href="#">I2C_PT_11[7:0]</a> |     |              |  |   |   |   |     |
|                     |                       |                                |     |              |  |   |   |   |     |
| 0x5<br>5C           | 0x<br>00              | <a href="#">CNT4[7:0]</a>      |     |              |  |   |   |   |     |
|                     |                       |                                |     |              |  |   |   |   |     |
| 0x5<br>5D           | 0x<br>00              | <a href="#">CNT5[7:0]</a>      |     |              |  |   |   |   |     |
|                     |                       |                                |     |              |  |   |   |   |     |

| ADDRESS       | RESET | NAME                               | MSB                   |                    |                     |                    |                   |                  |                    | LSB         |
|---------------|-------|------------------------------------|-----------------------|--------------------|---------------------|--------------------|-------------------|------------------|--------------------|-------------|
| 0x55E         | 0x00  | <a href="#">CNT6[7:0]</a>          | VID_PXL_CRC_ERR2[7:0] |                    |                     |                    |                   |                  |                    |             |
| 0x55F         | 0x00  | <a href="#">CNT7[7:0]</a>          | VID_PXL_CRC_ERR3[7:0] |                    |                     |                    |                   |                  |                    |             |
| 0x560         | 0x55  | <a href="#">PM_OV_STATI[7:0]</a>   | -                     | -                  | VDD18_OV_LEVEL[1:0] | -                  | -                 | OV_LEVEL[1:0]    |                    |             |
| 0x568         | 0x06  | <a href="#">PORT_TUN_ONLY[7:0]</a> | -                     | -                  | -                   | -                  | -                 | TUN_ONLY_2       | TUN_ONLY_1         | TUN_ONLY_CC |
| 0x569         | 0xAA  | <a href="#">UNLOCK_KEY[7:0]</a>    | UNLOCK_KEY[7:0]       |                    |                     |                    |                   |                  |                    |             |
| 0x570         | 0xFE  | <a href="#">PIO_SLEW_0[7:0]</a>    | PIO03_SLEW[1:0]       |                    | PIO02_SLEW[1:0]     |                    | PIO01_SLEW[1:0]   |                  | PIO00_SLEW[1:0]    |             |
| 0x571         | 0x83  | <a href="#">PIO_SLEW_1[7:0]</a>    | PIO07_SLEW[1:0]       |                    | -                   | -                  | -                 | -                | PIO04_SLEW[1:0]    |             |
| 0x572         | 0x02  | <a href="#">PIO_SLEW_2[7:0]</a>    | -                     | -                  | -                   | -                  | -                 | -                | PIO08_SLEW[1:0]    |             |
| 0x575         | 0x00  | <a href="#">HS_VS_ACT_Y[7:0]</a>   | -                     | DE_DET_Y           | VS_DET_Y            | HS_DET_Y           | -                 | -                | VS_POL_Y           | HS_POL_Y    |
| 0x576         | 0x00  | <a href="#">HS_VS_ACT_Z[7:0]</a>   | -                     | DE_DET_Z           | VS_DET_Z            | HS_DET_Z           | -                 | -                | VS_POL_Z           | HS_POL_Z    |
| 0x577         | 0x60  | <a href="#">DP_ORSTB_CTL[7:0]</a>  | -                     | DP_RST_MIPI3_CHKKB | DP_RST_STABLE_CHKKB | DP_RST_MIPI2_CHKKB | DP_RST_MIPI_CHKKB | DP_RST_VP_CHKKB  | -                  | -           |
| 0x578         | 0x15  | <a href="#">PM_OV_STATI2[7:0]</a>  | VTERM_OV_OEN          | VREG_OV_OEN        | VTERM_OV_LEVEL[1:0] |                    | -                 | -                | VREG_OV_LEVEL[1:0] |             |
| 0x579         | 0x00  | <a href="#">PM_OV_STATI3[7:0]</a>  | VTERM_OV_FLAG         | VREG_OV_FLAG       | -                   | -                  | -                 | -                | -                  | -           |
| <b>CC_EXT</b> |       |                                    |                       |                    |                     |                    |                   |                  |                    |             |
| 0x808         | 0x02  | <a href="#">UART_0[7:0]</a>        | -                     | -                  | REM_MS_EN_1         | LOC_MS_EN_1        | -                 | BYPASS_TO_1[1:0] |                    | BYPASS_EN_1 |

| AD<br>DR<br>ES<br>S | R<br>E<br>S<br>E<br>T | NAME                                | MSB                            |                                |                          |                   |                      |                          |                      | LSB             |
|---------------------|-----------------------|-------------------------------------|--------------------------------|--------------------------------|--------------------------|-------------------|----------------------|--------------------------|----------------------|-----------------|
| 0x8<br>09           | 0x<br>02              | <a href="#">UART_1[7:0]</a>         | -                              | -                              | REM_MS_EN<br>_2          | LOC_MS_E<br>N_2   | -                    | BYPASS_TO_2[1:0]         |                      | BYPASS_E<br>N_2 |
| 0x8<br>0E           | 0x<br>06              | <a href="#">I2C_PT_0[7:<br/>0]</a>  | -                              | I2C_REGS<br>LV_0_TIM<br>ED_OUT | -                        | -                 | -                    | I2C_INTREG_SLV_TO[2:0]   |                      |                 |
| 0x8<br>0F           | 0x<br>36              | <a href="#">I2C_PT_1[7:<br/>0]</a>  | I2C_REGSL<br>V_2_TIMED<br>_OUT | I2C_REGS<br>LV_1_TIM<br>ED_OUT | I2C_INTREG_SLV_2_TO[2:0] |                   |                      | I2C_INTREG_SLV_1_TO[2:0] |                      |                 |
| <b>GMSL1 A</b>      |                       |                                     |                                |                                |                          |                   |                      |                          |                      |                 |
| 0xB<br>02           | 0x<br>03              | <a href="#">GMSL1_2[7:<br/>0]</a>   | -                              | -                              | -                        | -                 | -                    | -                        | SRNG[1:0]            |                 |
| 0xB<br>04           | 0x<br>03              | <a href="#">GMSL1_4[7:<br/>0]</a>   | -                              | OUTENB                         | PRBSEN                   | CC_PORT_SEL[1:0]  |                      | -                        | REVCCEN              | FWGCCEN         |
| 0xB<br>05           | 0x<br>39              | <a href="#">GMSL1_5[7:<br/>0]</a>   | I2CMETHO<br>D                  | NO_REM_<br>MST                 | HVTR_MODE                | EN_EQ             | EQTUNE[3:0]          |                          |                      |                 |
| 0xB<br>06           | 0x<br>6F              | <a href="#">GMSL1_6[7:<br/>0]</a>   | HIGHIMM                        | MAX_RT_<br>EN                  | I2C_RT_EN                | GPI_COMP<br>_EN   | GPI_RT_E<br>N        | HV_SRC[2:0]              |                      |                 |
| 0xB<br>07           | 0x<br>00              | <a href="#">GMSL1_7[7:<br/>0]</a>   | DBL                            | DRS                            | BWS                      | -                 | HIBW                 | HVEN                     | -                    | PXL_CRC         |
| 0xB<br>08           | 0x<br>21              | <a href="#">GMSL1_8[7:<br/>0]</a>   | GPI_SEL[1:0]                   |                                | GPI_EN                   | EN_FSYNC<br>_TX   | -                    | PKTCC_EN                 | CC_CRC_LENGTH[1:0]   |                 |
| 0xB<br>0D           | 0x<br>00              | <a href="#">GMSL1_D[7:<br/>0]</a>   | I2C_LOC_A<br>CK                | -                              | -                        | -                 | -                    | HS_TRACK_F<br>SYNC       | -                    | -               |
| 0xB<br>0E           | 0x<br>00              | <a href="#">GMSL1_E[7:<br/>0]</a>   | DET_THR[7:0]                   |                                |                          |                   |                      |                          |                      |                 |
| 0xB<br>0F           | 0x<br>09              | <a href="#">GMSL1_F[7:<br/>0]</a>   | -                              | EN_DE_FI<br>LT                 | EN_HS_FILT               | EN_VS_FIL<br>T    | DE_EN                | -                        | -                    | PRBS_TYP<br>E   |
| 0xB<br>10           | 0x<br>02              | <a href="#">GMSL1_10[7:<br/>:0]</a> | RCEG_TYPE[1:0]                 |                                | RCEG_BOUN<br>D           | RCEG_ERR_NUM[3:0] |                      |                          | RCEG_EN              |                 |
| 0xB<br>11           | 0x<br>F0              | <a href="#">GMSL1_11[7:<br/>:0]</a> | RCEG_ERR_RATE[3:0]             |                                |                          |                   | RCEG_LO_BST_PRB[1:0] |                          | RCEG_LO_BST_LEN[1:0] |                 |

| AD DR ES S | R E S E T | NAME                          | MSB                 |                 |                        |                     |                |               |                 | LSB |
|------------|-----------|-------------------------------|---------------------|-----------------|------------------------|---------------------|----------------|---------------|-----------------|-----|
| 0xB<br>12  | 0x<br>52  | <a href="#">GMSL1_12[7:0]</a> | -                   | CC_CRC_ERR_EN   | LINE_CRC_LOC[1:0]      | LINE_CRC_EN_GMSL1   | -              | MAX_RT_ERR_EN | RCEG_ERR_PER_EN |     |
| 0xB<br>13  | 0x<br>C0  | <a href="#">GMSL1_13[7:0]</a> | EOM_EN_G1           | EOM_PER_MODE_G1 | EOM_MAN_T<br>RG_REQ_G1 | EOM_MIN_THR_G1[4:0] |                |               |                 |     |
| 0xB<br>14  | 0x<br>80  | <a href="#">GMSL1_14[7:0]</a> | AEQ_EN              | AEQ_PER_MODE    | AEQ_MAN_T<br>RG_REQ    | EOM_PER_THR[4:0]    |                |               |                 |     |
| 0xB<br>15  | 0x<br>00  | <a href="#">GMSL1_15[7:0]</a> | DET_ERR[7:0]        |                 |                        |                     |                |               |                 |     |
| 0xB<br>16  | 0x<br>00  | <a href="#">GMSL1_16[7:0]</a> | PRBS_ERR[7:0]       |                 |                        |                     |                |               |                 |     |
| 0xB<br>17  | 0x<br>00  | <a href="#">GMSL1_17[7:0]</a> | I2C_TIMED_OUT_GMSL1 | MAX_RT_ERR_I2C  | PRBS_OK                | GPI_IN              | MAX_RT_ERR_GPI | -             | -               | -   |
| 0xB<br>18  | 0x<br>00  | <a href="#">GMSL1_18[7:0]</a> | CC_RETR_CNT[7:0]    |                 |                        |                     |                |               |                 |     |
| 0xB<br>19  | 0x<br>00  | <a href="#">GMSL1_19[7:0]</a> | CC_CRC_ERRCNT[7:0]  |                 |                        |                     |                |               |                 |     |
| 0xB<br>1A  | 0x<br>00  | <a href="#">GMSL1_1A[7:0]</a> | RCEG_ERR_CNT[7:0]   |                 |                        |                     |                |               |                 |     |
| 0xB<br>1B  | 0x<br>00  | <a href="#">GMSL1_1B[7:0]</a> | -                   | -               | -                      | -                   | -              | LINE_CRC_ERR  | -               | -   |
| 0xB<br>1C  | 0x<br>00  | <a href="#">GMSL1_1C[7:0]</a> | -                   | -               | EOM_EYE_WIDTH[5:0]     |                     |                |               |                 |     |
| 0xB<br>1D  | 0x<br>00  | <a href="#">GMSL1_1D[7:0]</a> | -                   | -               | -                      | UNDERBO<br>OST_DET  | AEQ_BST[3:0]   |               |                 |     |
| 0xB<br>20  | 0x<br>00  | <a href="#">GMSL1_20[7:0]</a> | CRC_VALUE_0[7:0]    |                 |                        |                     |                |               |                 |     |
| 0xB<br>21  | 0x<br>00  | <a href="#">GMSL1_21[7:0]</a> | CRC_VALUE_1[7:0]    |                 |                        |                     |                |               |                 |     |
| 0xB<br>22  | 0x<br>00  | <a href="#">GMSL1_22[7:0]</a> | CRC_VALUE_2[7:0]    |                 |                        |                     |                |               |                 |     |

| AD<br>DR<br>ES<br>S | R<br>E<br>S<br>E<br>T | NAME                          | MSB                      |            |           |                  |             |                |                    | LSB       |
|---------------------|-----------------------|-------------------------------|--------------------------|------------|-----------|------------------|-------------|----------------|--------------------|-----------|
| 0xB<br>23           | 0x<br>00              | <a href="#">GMSL1_23[7:0]</a> | CRC_VALUE_3[7:0]         |            |           |                  |             |                |                    |           |
| 0xB<br>96           | 0x<br>01              | <a href="#">GMSL1_96[7:0]</a> | CONV_GMSL1_DATATYPE[4:0] |            |           |                  | DIS_HIBW_E  | CONV_GMSL1_EN  | DBL_ALIGN_TO       |           |
| 0xB<br>CA           | 0x<br>00              | <a href="#">GMSL1_CA[7:0]</a> | -                        | -          | -         | -                | -           | PHASELOCK      | WBLOCK_G1          | DATAOK    |
| 0xB<br>CB           | 0x<br>00              | <a href="#">GMSL1_CB[7:0]</a> | -                        | -          | -         | -                | -           | -              | -                  | LOCKED_G1 |
| 0xB<br>D1           | 0x<br>00              | <a href="#">GMSL1_D1[7:0]</a> | CNTL_OUT_ORD[2:0]        |            |           | CNTL_OUT_EN[4:0] |             |                |                    |           |
| 0xB<br>D2           | 0x<br>00              | GMSL1_D2[7:0]                 | -                        | -          | -         | -                | -           | -              | -                  | -         |
| 0xB<br>D3           | 0x<br>00              | GMSL1_D3[7:0]                 | -                        | -          | -         | -                | -           | -              | -                  | -         |
| <b>GMSL1 B</b>      |                       |                               |                          |            |           |                  |             |                |                    |           |
| 0xC<br>02           | 0x<br>03              | <a href="#">GMSL1_2[7:0]</a>  | -                        | -          | -         | -                | -           | -              | SRNG[1:0]          |           |
| 0xC<br>04           | 0x<br>03              | <a href="#">GMSL1_4[7:0]</a>  | -                        | OUTENB     | PRBSEN    | CC_PORT_SEL[1:0] |             | -              | REVCCEN            | FWGCCEN   |
| 0xC<br>05           | 0x<br>39              | <a href="#">GMSL1_5[7:0]</a>  | I2CMETHOD                | NO_REM_MST | HVTR_MODE | EN_EQ            | EQTUNE[3:0] |                |                    |           |
| 0xC<br>06           | 0x<br>6F              | <a href="#">GMSL1_6[7:0]</a>  | HIGHIMM                  | MAX_RT_EN  | I2C_RT_EN | GPI_COMP_EN      | GPI_RT_EN   | HV_SRC[2:0]    |                    |           |
| 0xC<br>07           | 0x<br>00              | <a href="#">GMSL1_7[7:0]</a>  | DBL                      | DRS        | BWS       | -                | HIBW        | HVEN           | -                  | PXL_CRC   |
| 0xC<br>08           | 0x<br>21              | <a href="#">GMSL1_8[7:0]</a>  | GPI_SEL[1:0]             |            | GPI_EN    | EN_FSYNC_TX      | -           | PKTCC_EN       | CC_CRC_LENGTH[1:0] |           |
| 0xC<br>0D           | 0x<br>00              | <a href="#">GMSL1_D[7:0]</a>  | I2C_LOC_ACK              | -          | -         | -                | -           | HS_TRACK_FSYNC | -                  | -         |
| 0xC<br>0E           | 0x<br>00              | <a href="#">GMSL1_E[7:0]</a>  | DET_THR[7:0]             |            |           |                  |             |                |                    |           |

| ADDRESS | RESET | NAME                        | MSB                 |                 |                    |                      |                   |                      |               | LSB             |
|---------|-------|-----------------------------|---------------------|-----------------|--------------------|----------------------|-------------------|----------------------|---------------|-----------------|
| 0xC0F   | 0x09  | <a href="#">GMSL1_FI7:0</a> | -                   | EN_DE_FILTER    | EN_HS_FILTER       | EN_VS_FILTER         | DE_EN             | -                    | -             | PRBS_TYPE       |
| 0xC10   | 0x02  | <a href="#">GMSL1_107:0</a> | RCEG_TYPE[1:0]      |                 | RCEG_BOUND         | RCEG_ERR_NUM[3:0]    |                   |                      | RCEG_EN       |                 |
| 0xC11   | 0xF0  | <a href="#">GMSL1_117:0</a> | RCEG_ERR_RATE[3:0]  |                 |                    | RCEG_LO_BST_PRB[1:0] |                   | RCEG_LO_BST_LEN[1:0] |               |                 |
| 0xC12   | 0x52  | <a href="#">GMSL1_127:0</a> | -                   | CC_CRC_ERR_EN   | LINE_CRC_LOC[1:0]  |                      | LINE_CRC_EN_GMSL1 | -                    | MAX_RT_ERR_EN | RCEG_ERR_PER_EN |
| 0xC13   | 0xC0  | <a href="#">GMSL1_137:0</a> | EOM_EN_G1           | EOM_PER_MODE_G1 | EOM_MAN_TRG_REQ_G1 | EOM_MIN_THR_G1[4:0]  |                   |                      |               |                 |
| 0xC14   | 0x80  | <a href="#">GMSL1_147:0</a> | AEQ_EN              | AEQ_PER_MODE    | AEQ_MAN_TRG_REQ    | EOM_PER_THR[4:0]     |                   |                      |               |                 |
| 0xC15   | 0x00  | <a href="#">GMSL1_157:0</a> | DET_ERR[7:0]        |                 |                    |                      |                   |                      |               |                 |
| 0xC16   | 0x00  | <a href="#">GMSL1_167:0</a> | PRBS_ERR[7:0]       |                 |                    |                      |                   |                      |               |                 |
| 0xC17   | 0x00  | <a href="#">GMSL1_177:0</a> | I2C_TIMED_OUT_GMSL1 | MAX_RT_ERR_I2C  | PRBS_OK            | GPI_IN               | MAX_RT_ERR_GPI    | -                    | -             | -               |
| 0xC18   | 0x00  | <a href="#">GMSL1_187:0</a> | CC_RETR_CNT[7:0]    |                 |                    |                      |                   |                      |               |                 |
| 0xC19   | 0x00  | <a href="#">GMSL1_197:0</a> | CC_CRC_ERRCNT[7:0]  |                 |                    |                      |                   |                      |               |                 |
| 0xC1A   | 0x00  | <a href="#">GMSL1_1A7:0</a> | RCEG_ERR_CNT[7:0]   |                 |                    |                      |                   |                      |               |                 |
| 0xC1B   | 0x00  | <a href="#">GMSL1_1B7:0</a> | -                   | -               | -                  | -                    | -                 | LINE_CRC_ERR         | -             | -               |
| 0xC1C   | 0x00  | <a href="#">GMSL1_1C7:0</a> | -                   | -               | EOM_EYE_WIDTH[5:0] |                      |                   |                      |               |                 |
| 0xC1D   | 0x00  | <a href="#">GMSL1_1D7:0</a> | -                   | -               | -                  | UNDERBOOST_DET       | AEQ_BST[3:0]      |                      |               |                 |

| ADDRESS             | RESET | NAME                                | MSB                      |   |   |                  |            |                    |                    | LSB |
|---------------------|-------|-------------------------------------|--------------------------|---|---|------------------|------------|--------------------|--------------------|-----|
| 0xC20               | 0x00  | <a href="#">GMSL1_20[7:0]</a>       | CRC_VALUE_0[7:0]         |   |   |                  |            |                    |                    |     |
| 0xC21               | 0x00  | <a href="#">GMSL1_21[7:0]</a>       | CRC_VALUE_1[7:0]         |   |   |                  |            |                    |                    |     |
| 0xC22               | 0x00  | <a href="#">GMSL1_22[7:0]</a>       | CRC_VALUE_2[7:0]         |   |   |                  |            |                    |                    |     |
| 0xC23               | 0x00  | <a href="#">GMSL1_23[7:0]</a>       | CRC_VALUE_3[7:0]         |   |   |                  |            |                    |                    |     |
| 0xC96               | 0x01  | <a href="#">GMSL1_96[7:0]</a>       | CONV_GMSL1_DATATYPE[4:0] |   |   |                  | DIS_HIBW_E | CONV_GMSL1_EN      | DBL_ALIGN_TO       |     |
| 0xC9A               | 0x00  | <a href="#">GMSL1_CA[7:0]</a>       | -                        | - | - | -                | PHASELOCK  | WBLOCK_G1          | DATAOK             |     |
| 0xC9B               | 0x00  | <a href="#">GMSL1_CB[7:0]</a>       | -                        | - | - | -                | -          | -                  | LOCKED_G1          |     |
| 0xC9D1              | 0x00  | <a href="#">GMSL1_D1[7:0]</a>       | CNTL_OUT_ORD[2:0]        |   |   | CNTL_OUT_EN[4:0] |            |                    |                    |     |
| 0xC9D2              | 0x00  | <a href="#">GMSL1_D2[7:0]</a>       | -                        | - | - | -                | -          | -                  | -                  |     |
| 0xC9D3              | 0x00  | <a href="#">GMSL1_D3[7:0]</a>       | -                        | - | - | -                | -          | -                  | -                  |     |
| <b>GMSL1_COMMON</b> |       |                                     |                          |   |   |                  |            |                    |                    |     |
| 0xF00               | 0x03  | <a href="#">GMSL1_EN[7:0]</a>       | -                        | - | - | -                | -          | LINK_EN_B          | LINK_EN_A          |     |
| 0xF01               | 0x00  | <a href="#">GMSL1_UART[7:0]</a>     | -                        | - | - | -                | -          | GMSL1_UART_ARB_TO  | GMSL1_UART_ARB_EN  |     |
| 0xF02               | 0x00  | <a href="#">COMMON1[7:0]</a>        | -                        | - | - | -                | -          | REM_ACK_ACKED_G1_B | REM_ACK_ACKED_G1_A |     |
| 0xF03               | 0x03  | <a href="#">GMSL1_ERR_OEN[7:0]</a>  | -                        | - | - | -                | -          | G1_B_ERR_OEN       | G1_A_ERR_OEN       |     |
| 0xF04               | 0x00  | <a href="#">GMSL1_ERR_FLAG[7:0]</a> | -                        | - | - | -                | -          | G1_B_ERR_FLAG      | G1_A_ERR_FLAG      |     |

| AD<br>DR<br>ES<br>S | R<br>E<br>S<br>E<br>T | NAME                                | MSB                 |                  |                |   |                  |                |                  | LSB    |  |
|---------------------|-----------------------|-------------------------------------|---------------------|------------------|----------------|---|------------------|----------------|------------------|--------|--|
| 0xF<br>05           | 0x<br>26              | <a href="#">I2C_0[7:0]</a>          | -                   | -                | G1_SLV_SH[1:0] |   | -                | G1_SLV_TO[2:0] |                  |        |  |
| 0xF<br>06           | 0x<br>56              | <a href="#">I2C_1[7:0]</a>          | EN_I2C_LO<br>OPBACK | G1_MST_BT[2:0]   |                |   | -                | G1_MST_TO[2:0] |                  |        |  |
| 0xF<br>07           | 0x<br>00              | <a href="#">I2C_2[7:0]</a>          | G1_SRC_A[6:0]       |                  |                |   |                  |                | -                |        |  |
| 0xF<br>08           | 0x<br>00              | <a href="#">I2C_3[7:0]</a>          | G1_DST_A[6:0]       |                  |                |   |                  |                | -                |        |  |
| 0xF<br>09           | 0x<br>00              | <a href="#">I2C_4[7:0]</a>          | G1_SRC_B[6:0]       |                  |                |   |                  |                | -                |        |  |
| 0xF<br>0A           | 0x<br>00              | <a href="#">I2C_5[7:0]</a>          | G1_DST_B[6:0]       |                  |                |   |                  |                | -                |        |  |
| <b>SPI_CC_WR</b>    |                       |                                     |                     |                  |                |   |                  |                |                  |        |  |
| 0x1<br>300          | 0x<br>00              | <a href="#">SPI_CC_WR<br/>_7:0]</a> | -                   | -                | -              | - | -                | -              | -                | -      |  |
| <b>SPI_CC_RD</b>    |                       |                                     |                     |                  |                |   |                  |                |                  |        |  |
| 0x1<br>380          | 0x<br>00              | <a href="#">SPI_CC_RD<br/>_7:0]</a> | -                   | -                | -              | - | -                | -              | -                | -      |  |
| <b>RLMS A</b>       |                       |                                     |                     |                  |                |   |                  |                |                  |        |  |
| 0x1<br>403          | 0x<br>0A              | <a href="#">RLMS3[7:0]</a>          | AdaptEn             | -                | -              | - | -                | -              | -                | -      |  |
| 0x1<br>404          | 0x<br>4B              | <a href="#">RLMS4[7:0]</a>          | EOM_CHK_AMOUNT[3:0] |                  |                |   | EOM_CHK_THR[1:0] |                | EOM_PER_<br>MODE | EOM_EN |  |
| 0x1<br>405          | 0x<br>10              | <a href="#">RLMS5[7:0]</a>          | EOM_MAN_<br>TRG_REQ | EOM_MIN_THR[6:0] |                |   |                  |                |                  |        |  |
| 0x1<br>406          | 0x<br>80              | <a href="#">RLMS6[7:0]</a>          | EOM_PV_M<br>ODE     | EOM_RST_THR[6:0] |                |   |                  |                |                  |        |  |
| 0x1<br>407          | 0x<br>00              | <a href="#">RLMS7[7:0]</a>          | EOM_DONE            | EOM[6:0]         |                |   |                  |                |                  |        |  |
| 0x1<br>40A          | 0x<br>08              | <a href="#">RLMSA[7:0]</a>          | -                   | -                | -              | - | DFEApdDly[3:0]   |                |                  |        |  |

| AD<br>DR<br>ES<br>S | R<br>E<br>S<br>E<br>T | NAME                        | MSB                  |                     |              |   |   |                |                | LSB     |
|---------------------|-----------------------|-----------------------------|----------------------|---------------------|--------------|---|---|----------------|----------------|---------|
| 0x1<br>40B          | 0x<br>44              | <a href="#">RLMSB[7:0]</a>  | AGCAcqDly[3:0]       |                     |              | - | - | -              | -              | -       |
| 0x1<br>418          | 0x<br>0F              | <a href="#">RLMS18[7:0]</a> | -                    | -                   | -            | - | - | VgaHiGain      | -              | -       |
| 0x1<br>41F          | 0x<br>A7              | <a href="#">RLMS1F[7:0]</a> | AGCInitG2[7:0]       |                     |              |   |   |                |                |         |
| 0x1<br>421          | 0x<br>04              | <a href="#">RLMS21[7:0]</a> | -                    | -                   | BSTMuH[5:0]  |   |   |                |                |         |
| 0x1<br>423          | 0x<br>45              | <a href="#">RLMS23[7:0]</a> | -                    | -                   | BSTInit[5:0] |   |   |                |                |         |
| 0x1<br>431          | 0x<br>18              | <a href="#">RLMS31[7:0]</a> | -                    | -                   | OSNMuH[5:0]  |   |   |                |                |         |
| 0x1<br>43E          | 0x<br>94              | <a href="#">RLMS3E[7:0]</a> | ErrChPhSec<br>TAFR6G | ErrChPhSecFR6G[6:0] |              |   |   |                |                |         |
| 0x1<br>43F          | 0x<br>54              | <a href="#">RLMS3F[7:0]</a> | ErrChPhPriT<br>AFR6G | ErrChPhPriFR6G[6:0] |              |   |   |                |                |         |
| 0x1<br>445          | 0x<br>C<br>8          | <a href="#">RLMS45[7:0]</a> | CRULpCtrlS<br>REn    | CRUSSCS<br>elSREn   | -            | - | - | -              | -              | -       |
| 0x1<br>446          | 0x<br>B3              | <a href="#">RLMS46[7:0]</a> | -                    | -                   | -            | - | - | CRULpCtrl[2:0] |                |         |
| 0x1<br>447          | 0x<br>03              | <a href="#">RLMS47[7:0]</a> | -                    | -                   | -            | - | - | CRUSSCSel[1:0] |                | -       |
| 0x1<br>449          | 0x<br>F5              | <a href="#">RLMS49[7:0]</a> | -                    | -                   | -            | - | - | ErrChPwrUp     | -              | -       |
| 0x1<br>464          | 0x<br>90              | <a href="#">RLMS64[7:0]</a> | -                    | -                   | -            | - | - | -              | TxSSCMode[1:0] |         |
| 0x1<br>470          | 0x<br>01              | <a href="#">RLMS70[7:0]</a> | -                    | TxSSCFrqCtrl[6:0]   |              |   |   |                |                |         |
| 0x1<br>471          | 0x<br>02              | <a href="#">RLMS71[7:0]</a> | -                    | TxSSCCenSprSt[5:0]  |              |   |   |                |                | TxSSCEn |

| ADDRESS | REGISTER | NAME                        | MSB                    |                       |                      |                        |               |                  |                  | LSB |
|---------|----------|-----------------------------|------------------------|-----------------------|----------------------|------------------------|---------------|------------------|------------------|-----|
| 0x1472  | 0xCF     | <a href="#">RLMS72[7:0]</a> | TxSSCPreScL[7:0]       |                       |                      |                        |               |                  |                  |     |
| 0x1473  | 0x00     | <a href="#">RLMS73[7:0]</a> | -                      | -                     | -                    | -                      | -             | TxSSCPreScH[2:0] |                  |     |
| 0x1474  | 0x00     | <a href="#">RLMS74[7:0]</a> | TxSSCPhL[7:0]          |                       |                      |                        |               |                  |                  |     |
| 0x1475  | 0x00     | <a href="#">RLMS75[7:0]</a> | -                      | TxSSCPhH[6:0]         |                      |                        |               |                  |                  |     |
| 0x1476  | 0x90     | <a href="#">RLMS76[7:0]</a> | phyc_rep_ecp_dly[2:0]  |                       |                      | phyc_ecp_cal_time[2:0] |               |                  | TxSSCPhQuad[1:0] |     |
| 0x148C  | 0x00     | <a href="#">RLMS8C[7:0]</a> | -                      | cap_pre_out_rlms[6:0] |                      |                        |               |                  |                  |     |
| 0x1495  | 0x69     | <a href="#">RLMS95[7:0]</a> | TxAmpIMan<br>En        | -                     | TxAmpIMan[5:0]       |                        |               |                  |                  |     |
| 0x1498  | 0x40     | <a href="#">RLMS98[7:0]</a> | Cal_cap_pre<br>_out_en | -                     | -                    | -                      | -             | -                | -                | -   |
| 0x14A4  | 0xBD     | <a href="#">RLMSA4[7:0]</a> | AEQ_PER_MULT[1:0]      |                       | AEQ_PER[5:0]         |                        |               |                  |                  |     |
| 0x14A5  | 0x50     | <a href="#">RLMSA5[7:0]</a> | -                      | -                     | PHYC_WBLOCK_DLY[1:0] |                        | -             | -                | -                | -   |
| 0x14A7  | 0x01     | <a href="#">RLMSA7[7:0]</a> | MAN_CTRL<br>_EN        | -                     | -                    | -                      | -             | -                | -                | -   |
| 0x14A8  | 0x00     | <a href="#">RLMSA8[7:0]</a> | FW_PHY_C<br>TRL        | FW_PHY_<br>PU_TX      | FW_PHY_RS<br>TB      | -                      | -             | -                | -                | -   |
| 0x14A9  | 0x00     | <a href="#">RLMSA9[7:0]</a> | FW_REPCA<br>L_RSTB     | -                     | FW_TXD_SQ<br>UELCH   | FW_TXD_E<br>N          | FW_RXD_<br>EN | -                | -                | -   |
| 0x14AC  | 0xA0     | <a href="#">RLMSAC[7:0]</a> | -                      | ErrChPhSecFR3G[6:0]   |                      |                        |               |                  |                  |     |

| ADDRESS       | REGISTER | NAME                             | MSB                 |                     |              |                  |                |              |        | LSB |  |
|---------------|----------|----------------------------------|---------------------|---------------------|--------------|------------------|----------------|--------------|--------|-----|--|
| 0x14AD        | 0x60     | <a href="#">RLMSAD[7:0]</a><br>↓ | -                   | ErrChPhPriFR3G[6:0] |              |                  |                |              |        |     |  |
| <b>RLMS B</b> |          |                                  |                     |                     |              |                  |                |              |        |     |  |
| 0x1503        | 0x0A     | <a href="#">RLMS3[7:0]</a>       | AdaptEn             | -                   | -            | -                | -              | -            | -      | -   |  |
| 0x1504        | 0x4B     | <a href="#">RLMS4[7:0]</a>       | EOM_CHK_AMOUNT[3:0] |                     |              | EOM_CHK_THR[1:0] |                | EOM_PER_MODE | EOM_EN |     |  |
| 0x1505        | 0x10     | <a href="#">RLMS5[7:0]</a>       | EOM_MAN_TRG_REQ     | EOM_MIN_THR[6:0]    |              |                  |                |              |        |     |  |
| 0x1506        | 0x80     | <a href="#">RLMS6[7:0]</a>       | EOM_PV_MODE         | EOM_RST_THR[6:0]    |              |                  |                |              |        |     |  |
| 0x1507        | 0x00     | <a href="#">RLMS7[7:0]</a>       | EOM_DONE            | EOM[6:0]            |              |                  |                |              |        |     |  |
| 0x150A        | 0x08     | <a href="#">RLMSA[7:0]</a>       | -                   | -                   | -            | -                | DFEAdpDly[3:0] |              |        |     |  |
| 0x150B        | 0x44     | <a href="#">RLMSB[7:0]</a>       | AGCAcqDly[3:0]      |                     |              | -                | -              | -            | -      |     |  |
| 0x1518        | 0x0F     | <a href="#">RLMS18[7:0]</a>      | -                   | -                   | -            | -                | -              | VgaHiGain    | -      | -   |  |
| 0x151F        | 0xA7     | <a href="#">RLMS1F[7:0]</a>      | AGCInitG2[7:0]      |                     |              |                  |                |              |        |     |  |
| 0x1521        | 0x04     | <a href="#">RLMS21[7:0]</a>      | -                   | -                   | BSTMuH[5:0]  |                  |                |              |        |     |  |
| 0x1523        | 0x45     | <a href="#">RLMS23[7:0]</a>      | -                   | -                   | BSTInit[5:0] |                  |                |              |        |     |  |
| 0x1531        | 0x18     | <a href="#">RLMS31[7:0]</a>      | -                   | -                   | OSNMuH[5:0]  |                  |                |              |        |     |  |
| 0x153E        | 0x94     | <a href="#">RLMS3E[7:0]</a>      | ErrChPhSecTAFR6G    | ErrChPhSecFR6G[6:0] |              |                  |                |              |        |     |  |
| 0x153F        | 0x54     | <a href="#">RLMS3F[7:0]</a>      | ErrChPhPriTAFR6G    | ErrChPhPriFR6G[6:0] |              |                  |                |              |        |     |  |

| AD<br>DR<br>ES<br>S | R<br>E<br>S<br>E<br>T | NAME                        | MSB                    |                       |                |                        |   |                  |                  | LSB     |
|---------------------|-----------------------|-----------------------------|------------------------|-----------------------|----------------|------------------------|---|------------------|------------------|---------|
| 0x1<br>545          | 0x<br>C<br>8          | <a href="#">RLMS45[7:0]</a> | CRULpCtrlS<br>REn      | CRUSSCS<br>elSREn     | -              | -                      | - | -                | -                | -       |
| 0x1<br>546          | 0x<br>B3              | <a href="#">RLMS46[7:0]</a> | -                      | -                     | -              | -                      | - | CRULpCtrl[2:0]   |                  |         |
| 0x1<br>547          | 0x<br>03              | <a href="#">RLMS47[7:0]</a> | -                      | -                     | -              | -                      | - | CRUSSCSel[1:0]   |                  | -       |
| 0x1<br>549          | 0x<br>F5              | <a href="#">RLMS49[7:0]</a> | -                      | -                     | -              | -                      | - | ErrChPwrUp       | -                | -       |
| 0x1<br>564          | 0x<br>90              | <a href="#">RLMS64[7:0]</a> | -                      | -                     | -              | -                      | - | -                | TxSSCMode[1:0]   |         |
| 0x1<br>570          | 0x<br>01              | <a href="#">RLMS70[7:0]</a> | -                      | TxSSCFrqCtrl[6:0]     |                |                        |   |                  |                  |         |
| 0x1<br>571          | 0x<br>02              | <a href="#">RLMS71[7:0]</a> | -                      | TxSSCCenSprSt[5:0]    |                |                        |   |                  |                  | TxSSCEn |
| 0x1<br>572          | 0x<br>C<br>F          | <a href="#">RLMS72[7:0]</a> | TxSSCPreScL[7:0]       |                       |                |                        |   |                  |                  |         |
| 0x1<br>573          | 0x<br>00              | <a href="#">RLMS73[7:0]</a> | -                      | -                     | -              | -                      | - | TxSSCPreScH[2:0] |                  |         |
| 0x1<br>574          | 0x<br>00              | <a href="#">RLMS74[7:0]</a> | TxSSCPhL[7:0]          |                       |                |                        |   |                  |                  |         |
| 0x1<br>575          | 0x<br>00              | <a href="#">RLMS75[7:0]</a> | -                      | TxSSCPhH[6:0]         |                |                        |   |                  |                  |         |
| 0x1<br>576          | 0x<br>90              | <a href="#">RLMS76[7:0]</a> | phyc_rep_ecp_dly[2:0]  |                       |                | phyc_ecp_cal_time[2:0] |   |                  | TxSSCPhQuad[1:0] |         |
| 0x1<br>58<br>C      | 0x<br>00              | <a href="#">RLMS8C[7:0]</a> | -                      | cap_pre_out_rlms[6:0] |                |                        |   |                  |                  |         |
| 0x1<br>595          | 0x<br>69              | <a href="#">RLMS95[7:0]</a> | TxAmpIMan<br>En        | -                     | TxAmpIMan[5:0] |                        |   |                  |                  |         |
| 0x1<br>598          | 0x<br>40              | <a href="#">RLMS98[7:0]</a> | Cal_cap_pre<br>_out_en | -                     | -              | -                      | - | -                | -                | -       |

| ADDRESS          | REGISTER | NAME                         | MSB                               |                               |                                      |                                    |           |   |   | LSB               |
|------------------|----------|------------------------------|-----------------------------------|-------------------------------|--------------------------------------|------------------------------------|-----------|---|---|-------------------|
| 0x15A4           | 0xBD     | <a href="#">RLMSA4[7:0]</a>  | AEQ_PER_MULT[1:0]                 |                               | AEQ_PER[5:0]                         |                                    |           |   |   |                   |
| 0x15A5           | 0x50     | <a href="#">RLMSA5[7:0]</a>  | -                                 | -                             | PHYC_WBLOCK_DLY[1:0]                 | -                                  | -         | - | - |                   |
| 0x15A7           | 0x01     | <a href="#">RLMSA7[7:0]</a>  | MAN_CTRL_EN                       | -                             | -                                    | -                                  | -         | - | - |                   |
| 0x15A8           | 0x00     | <a href="#">RLMSA8[7:0]</a>  | FW_PHY_CTRL                       | FW_PHY_PU_TX                  | FW_PHY_RSTB                          | -                                  | -         | - | - |                   |
| 0x15A9           | 0x00     | <a href="#">RLMSA9[7:0]</a>  | FW_REPCAL_RSTB                    | -                             | FW_TXD_SQUELCH                       | FW_TXD_EN                          | FW_RXD_EN | - | - |                   |
| 0x15AC           | 0xA0     | <a href="#">RLMSAC7:0]</a>   | -                                 | ErrChPhSecFR3G[6:0]           |                                      |                                    |           |   |   |                   |
| 0x15AD           | 0x60     | <a href="#">RLMSAD7:0]</a>   | -                                 | ErrChPhPriFR3G[6:0]           |                                      |                                    |           |   |   |                   |
| <b>DPLL CSI1</b> |          |                              |                                   |                               |                                      |                                    |           |   |   |                   |
| 0x1C00           | 0xF5     | <a href="#">DPLL_0[7:0]</a>  | -                                 | -                             | -                                    | -                                  | -         | - | - | config_soft_rst_n |
| 0x1C03           | 0x82     | <a href="#">DPLL_3[7:0]</a>  | config_sel_clock_out_use_external | config_disable_div_output_exp | config_use_internal_pll_mod_e_values | config_use_internal_divider_values | -         | - | - | -                 |
| 0x1C07           | 0x04     | <a href="#">DPLL_7[7:0]</a>  | config_div_fb_L                   | config_div_in[4:0]            |                                      |                                    |           |   | - | -                 |
| 0x1C08           | 0x14     | <a href="#">DPLL_8[7:0]</a>  | config_div_fb_H[7:0]              |                               |                                      |                                    |           |   |   |                   |
| 0x1C0A           | 0x81     | <a href="#">DPLL_10[7:0]</a> | -                                 | config_div_out_exp[2:0]       |                                      |                                    | -         | - | - | -                 |
| <b>DPLL CSI2</b> |          |                              |                                   |                               |                                      |                                    |           |   |   |                   |

| ADDRESS          | REGISTER | NAME                         | MSB                               |                               |                                      |                                    |   |   |   | LSB               |   |
|------------------|----------|------------------------------|-----------------------------------|-------------------------------|--------------------------------------|------------------------------------|---|---|---|-------------------|---|
| 0x1D00           | 0xF5     | <a href="#">DPLL_0[7:0]</a>  | -                                 | -                             | -                                    | -                                  | - | - | - | config_soft_rst_n |   |
| 0x1D03           | 0x82     | <a href="#">DPLL_3[7:0]</a>  | config_sel_clock_out_use_external | config_disable_div_output_exp | config_use_internal_pll_mod_e_values | config_use_internal_divider_values | - | - | - | -                 |   |
| 0x1D07           | 0x04     | <a href="#">DPLL_7[7:0]</a>  | config_div_fb_L                   | config_div_in[4:0]            |                                      |                                    |   | - | - | -                 |   |
| 0x1D08           | 0x14     | <a href="#">DPLL_8[7:0]</a>  | config_div_fb_H[7:0]              |                               |                                      |                                    |   |   |   | -                 | - |
| 0x1D0A           | 0x81     | <a href="#">DPLL_10[7:0]</a> | -                                 | config_div_out_exp[2:0]       |                                      | -                                  | - | - | - | -                 |   |
| <b>DPLL CSI3</b> |          |                              |                                   |                               |                                      |                                    |   |   |   |                   |   |
| 0x1E00           | 0xF5     | <a href="#">DPLL_0[7:0]</a>  | -                                 | -                             | -                                    | -                                  | - | - | - | config_soft_rst_n |   |
| 0x1E03           | 0x82     | <a href="#">DPLL_3[7:0]</a>  | config_sel_clock_out_use_external | config_disable_div_output_exp | config_use_internal_pll_mod_e_values | config_use_internal_divider_values | - | - | - | -                 |   |
| 0x1E07           | 0x04     | <a href="#">DPLL_7[7:0]</a>  | config_div_fb_L                   | config_div_in[4:0]            |                                      |                                    |   | - | - | -                 |   |
| 0x1E08           | 0x14     | <a href="#">DPLL_8[7:0]</a>  | config_div_fb_H[7:0]              |                               |                                      |                                    |   |   |   | -                 | - |
| 0x1E0A           | 0x81     | <a href="#">DPLL_10[7:0]</a> | -                                 | config_div_out_exp[2:0]       |                                      | -                                  | - | - | - | -                 |   |
| <b>DPLL CSI4</b> |          |                              |                                   |                               |                                      |                                    |   |   |   |                   |   |
| 0x1F00           | 0xF5     | <a href="#">DPLL_0[7:0]</a>  | -                                 | -                             | -                                    | -                                  | - | - | - | config_soft_rst_n |   |
| 0x1F03           | 0x82     | <a href="#">DPLL_3[7:0]</a>  | config_sel_clock_out_use_external | config_disable_div_output_exp | config_use_internal_pll_mod_e_values | config_use_internal_divider_values | - | - | - | -                 |   |

| AD DR ES S | R E S E T | NAME                                       | MSB                                 |                         |   |   |                      |                            |                        | LSB             |
|------------|-----------|--|-------------------------------------|-------------------------|---|---|----------------------|----------------------------|------------------------|-----------------|
| 0x1 F07    | 0x 04     | <a href="#">DPLL 7[7:0]</a>                | config_div_f b_L                    | config_div_in[4:0]      |   |   |                      |                            | -                      | -               |
| 0x1 F08    | 0x 14     | <a href="#">DPLL 8[7:0]</a>                | config_div_fb_H[7:0]                |                         |   |   |                      |                            |                        |                 |
| 0x1 F0A    | 0x 81     | <a href="#">DPLL 10[7:0]</a>               | -                                   | config_div_out_exp[2:0] |   |   | -                    | -                          | -                      | -               |
| <b>FEC</b> |           |  |                                     |                         |   |   |                      |                            |                        |                 |
| 0x2 000    | 0x 00     | <a href="#">CLEAR STATS[7:0]</a>           | -                                   | -                       | - | - | CLEAR_BITS_CORRECTED | CLEAR_BLOCKS_UNCORRECTABLE | CLEAR_BLOCKS_PROCESSED | CLEAR_ALL_STATS |
| 0x2 001    | 0x 00     | <a href="#">STATS CONTROL[7:0]</a>         | -                                   | -                       | - | - | -                    | -                          | -                      | STATS_ENABLE    |
| 0x2 008    | 0x 00     | <a href="#">CORRECTED_THRESHOLD_0[7:0]</a> | BIT_ERRS_CORRECTED_THRESHOLD_0[7:0] |                         |   |   |                      |                            |                        |                 |
| 0x2 009    | 0x 00     | <a href="#">CORRECTED_THRESHOLD_1[7:0]</a> | BIT_ERRS_CORRECTED_THRESHOLD_1[7:0] |                         |   |   |                      |                            |                        |                 |
| 0x2 00A    | 0x 00     | <a href="#">CORRECTED_THRESHOLD_2[7:0]</a> | BIT_ERRS_CORRECTED_THRESHOLD_2[7:0] |                         |   |   |                      |                            |                        |                 |
| 0x2 00B    | 0x 00     | <a href="#">CORRECTED_THRESHOLD_3[7:0]</a> | BIT_ERRS_CORRECTED_THRESHOLD_3[7:0] |                         |   |   |                      |                            |                        |                 |
| 0x2 00C    | 0x 00     | <a href="#">ERROR_THRESHOLD_0[7:0]</a>     | UNCORRECTED_ERROR_THRESHOLD_0[7:0]  |                         |   |   |                      |                            |                        |                 |
| 0x2 00D    | 0x 00     | <a href="#">ERROR_THRESHOLD_1[7:0]</a>     | UNCORRECTED_ERROR_THRESHOLD_1[7:0]  |                         |   |   |                      |                            |                        |                 |
| 0x2 00E    | 0x 00     | <a href="#">ERROR_THRESHOLD_2[7:0]</a>     | UNCORRECTED_ERROR_THRESHOLD_2[7:0]  |                         |   |   |                      |                            |                        |                 |

| AD<br>DR<br>ES<br>S | R<br>E<br>S<br>E<br>T | NAME  | MSB |  |  |  |  |  |  | LSB                                |
|---------------------|-----------------------|---|-----|--|--|--|--|--|--|------------------------------------|
| 0x2<br>00F          | 0x<br>00              | <a href="#">ERROR_TH<br/>RESHOLD_3<br/>[7:0]</a>      |     |  |  |  |  |  |  | UNCORRECTED_ERROR_THRESHOLD_3[7:0] |
| 0x2<br>020          | 0x<br>00              | <a href="#">BLOCKS_UN<br/>CORRECTA<br/>BLE_0[7:0]</a> |     |  |  |  |  |  |  | UNCORRECTABLE_BLOCKS_0[7:0]        |
| 0x2<br>021          | 0x<br>00              | <a href="#">BLOCKS_UN<br/>CORRECTA<br/>BLE_1[7:0]</a> |     |  |  |  |  |  |  | UNCORRECTABLE_BLOCKS_1[7:0]        |
| 0x2<br>022          | 0x<br>00              | <a href="#">BLOCKS_UN<br/>CORRECTA<br/>BLE_2[7:0]</a> |     |  |  |  |  |  |  | UNCORRECTABLE_BLOCKS_2[7:0]        |
| 0x2<br>023          | 0x<br>00              | <a href="#">BLOCKS_UN<br/>CORRECTA<br/>BLE_3[7:0]</a> |     |  |  |  |  |  |  | UNCORRECTABLE_BLOCKS_3[7:0]        |
| 0x2<br>024          | 0x<br>00              | <a href="#">BITS CORR<br/>ECTED_0[7:<br/>0]</a>       |     |  |  |  |  |  |  | BIT_ERRS_CORRECTED_0[7:0]          |
| 0x2<br>025          | 0x<br>00              | <a href="#">BITS CORR<br/>ECTED_1[7:<br/>0]</a>       |     |  |  |  |  |  |  | BIT_ERRS_CORRECTED_1[7:0]          |
| 0x2<br>026          | 0x<br>00              | <a href="#">BITS CORR<br/>ECTED_2[7:<br/>0]</a>       |     |  |  |  |  |  |  | BIT_ERRS_CORRECTED_2[7:0]          |
| 0x2<br>027          | 0x<br>00              | <a href="#">BITS CORR<br/>ECTED_3[7:<br/>0]</a>       |     |  |  |  |  |  |  | BIT_ERRS_CORRECTED_3[7:0]          |
| 0x2<br>028          | 0x<br>00              | <a href="#">BLOCKS PR<br/>OCESSED_0<br/>[7:0]</a>     |     |  |  |  |  |  |  | BLOCKS_PROCESSED_0[7:0]            |
| 0x2<br>029          | 0x<br>00              | <a href="#">BLOCKS PR<br/>OCESSED_1<br/>[7:0]</a>     |     |  |  |  |  |  |  | BLOCKS_PROCESSED_1[7:0]            |
| 0x2<br>02A          | 0x<br>00              | <a href="#">BLOCKS PR<br/>OCESSED_2<br/>[7:0]</a>     |     |  |  |  |  |  |  | BLOCKS_PROCESSED_2[7:0]            |

| AD DR ES S   | R E S E T | NAME  | MSB                                   |   |   |   |                        |                              |                          | LSB               |  |
|--------------|-----------|---|---------------------------------------|---|---|---|------------------------|------------------------------|--------------------------|-------------------|--|
| 0x202B       | 0x00      | <a href="#">BLOCKS_PROCESSED_3[7:0]</a>     | BLOCKS_PROCESSED_3[7:0]               |   |   |   |                        |                              |                          |                   |  |
| <b>FEC_B</b> |           |   |                                       |   |   |   |                        |                              |                          |                   |  |
| 0x2100       | 0x00      | <a href="#">CLEAR_STATS[7:0]</a>            | -                                     | - | - | - | CLEAR_BITS_CORRECTED_B | CLEAR_BLOCKS_UNCORRECTABLE_B | CLEAR_BLOCKS_PROCESSED_B | CLEAR_ALL_STATS_B |  |
| 0x2101       | 0x00      | <a href="#">STATS_CONTROL[7:0]</a>          | -                                     | - | - | - | -                      | -                            | -                        | STATS_ENABLE_B    |  |
| 0x2108       | 0x00      | <a href="#">CORRECTED_THRESHOLD_0[7:0]</a>  | BIT_ERRS_CORRECTED_THRESHOLD_0_B[7:0] |   |   |   |                        |                              |                          |                   |  |
| 0x2109       | 0x00      | <a href="#">CORRECTED_THRESHOLD_1[7:0]</a>  | BIT_ERRS_CORRECTED_THRESHOLD_1_B[7:0] |   |   |   |                        |                              |                          |                   |  |
| 0x210A       | 0x00      | <a href="#">CORRECTED_THRESHOLD_2[7:0]</a>  | BIT_ERRS_CORRECTED_THRESHOLD_2_B[7:0] |   |   |   |                        |                              |                          |                   |  |
| 0x210B       | 0x00      | <a href="#">CORRECTED_THRESHOLD_3[7:0]</a>  | BIT_ERRS_CORRECTED_THRESHOLD_3_B[7:0] |   |   |   |                        |                              |                          |                   |  |
| 0x210C       | 0x00      | <a href="#">ERROR_THRESHOLD_0[7:0]</a>      | UNCORRECTED_ERROR_THRESHOLD_0_B[7:0]  |   |   |   |                        |                              |                          |                   |  |
| 0x210D       | 0x00      | <a href="#">ERROR_THRESHOLD_1[7:0]</a>      | UNCORRECTED_ERROR_THRESHOLD_1_B[7:0]  |   |   |   |                        |                              |                          |                   |  |
| 0x210E       | 0x00      | <a href="#">ERROR_THRESHOLD_2[7:0]</a>      | UNCORRECTED_ERROR_THRESHOLD_2_B[7:0]  |   |   |   |                        |                              |                          |                   |  |
| 0x210F       | 0x00      | <a href="#">ERROR_THRESHOLD_3[7:0]</a>      | UNCORRECTED_ERROR_THRESHOLD_3_B[7:0]  |   |   |   |                        |                              |                          |                   |  |
| 0x2120       | 0x00      | <a href="#">BLOCKS_UNCORRECTABLE_0[7:0]</a> | UNCORRECTABLE_BLOCKS_0_B[7:0]         |   |   |   |                        |                              |                          |                   |  |

| AD DR ES S       | R E S E T | NAME  | MSB |   |   |                     |                    |                      |               | LSB                           |
|------------------|-----------|---|-----|---|---|---------------------|--------------------|----------------------|---------------|-------------------------------|
| 0x2<br>121       | 0x<br>00  | <a href="#">BLOCKS UNCORRECTABLE 1[7:0]</a> |     |   |   |                     |                    |                      |               | UNCORRECTABLE_BLOCKS_1_B[7:0] |
| 0x2<br>122       | 0x<br>00  | <a href="#">BLOCKS UNCORRECTABLE 2[7:0]</a> |     |   |   |                     |                    |                      |               | UNCORRECTABLE_BLOCKS_2_B[7:0] |
| 0x2<br>123       | 0x<br>00  | <a href="#">BLOCKS UNCORRECTABLE 3[7:0]</a> |     |   |   |                     |                    |                      |               | UNCORRECTABLE_BLOCKS_3_B[7:0] |
| 0x2<br>124       | 0x<br>00  | <a href="#">BITS CORRECTED 0[7:0]</a>       |     |   |   |                     |                    |                      |               | BIT_ERRS_CORRECTED_0_B[7:0]   |
| 0x2<br>125       | 0x<br>00  | <a href="#">BITS CORRECTED 1[7:0]</a>       |     |   |   |                     |                    |                      |               | BIT_ERRS_CORRECTED_1_B[7:0]   |
| 0x2<br>126       | 0x<br>00  | <a href="#">BITS CORRECTED 2[7:0]</a>       |     |   |   |                     |                    |                      |               | BIT_ERRS_CORRECTED_2_B[7:0]   |
| 0x2<br>127       | 0x<br>00  | <a href="#">BITS CORRECTED 3[7:0]</a>       |     |   |   |                     |                    |                      |               | BIT_ERRS_CORRECTED_3_B[7:0]   |
| 0x2<br>128       | 0x<br>00  | <a href="#">BLOCKS PROCESSED 0[7:0]</a>     |     |   |   |                     |                    |                      |               | BLOCKS_PROCESSED_0_B[7:0]     |
| 0x2<br>129       | 0x<br>00  | <a href="#">BLOCKS PROCESSED 1[7:0]</a>     |     |   |   |                     |                    |                      |               | BLOCKS_PROCESSED_1_B[7:0]     |
| 0x2<br>12A       | 0x<br>00  | <a href="#">BLOCKS PROCESSED 2[7:0]</a>     |     |   |   |                     |                    |                      |               | BLOCKS_PROCESSED_2_B[7:0]     |
| 0x2<br>12B       | 0x<br>00  | <a href="#">BLOCKS PROCESSED 3[7:0]</a>     |     |   |   |                     |                    |                      |               | BLOCKS_PROCESSED_3_B[7:0]     |
| <b>FUNC_SAFE</b> |           |   |     |   |   |                     |                    |                      |               |                               |
| 0x3<br>000       | 0x<br>00  | <a href="#">REGCRC0[7:0]</a>                | -   | - | - | GEN_ROLLI<br>NG_CRC | I2C_WR_C<br>OMPUTE | PERIODIC_C<br>OMPUTE | CHECK_CR<br>C | RESET_CR<br>C                 |

| AD<br>DR<br>ES<br>S | R<br>E<br>S<br>E<br>T | NAME                               | MSB                              |                               |                      |                           |                   |               |                                | LSB                            |
|---------------------|-----------------------|------------------------------------|----------------------------------|-------------------------------|----------------------|---------------------------|-------------------|---------------|--------------------------------|--------------------------------|
| 0x3<br>001          | 0x<br>00              | <a href="#">REGCRC1[7:0]</a>       | CRC_PERIOD[7:0]                  |                               |                      |                           |                   |               |                                |                                |
| 0x3<br>002          | 0x<br>00              | <a href="#">REGCRC2[7:0]</a>       | REGCRC_LSB[7:0]                  |                               |                      |                           |                   |               |                                |                                |
| 0x3<br>003          | 0x<br>00              | <a href="#">REGCRC3[7:0]</a>       | REGCRC_MSB[7:0]                  |                               |                      |                           |                   |               |                                |                                |
| 0x3<br>008          | 0x<br>00              | <a href="#">I2C_UART_CRC0[7:0]</a> | -                                | -                             | -                    | -                         | -                 | -             | -                              | RESET_MS<br>GCNTR              |
| 0x3<br>009          | 0x<br>00              | <a href="#">I2C_UART_CRC1[7:0]</a> | MSGCNTR_ERR_THR[2:0]             |                               |                      | CRC_ERR_THR[2:0]          |                   |               | RESET_MS<br>GCNTR_ER<br>R_CNT  | RESET_CR<br>C_ERR_CN<br>T      |
| 0x3<br>00A          | 0x<br>00              | <a href="#">I2C_UART_CRC2[7:0]</a> | CRC_VAL[7:0]                     |                               |                      |                           |                   |               |                                |                                |
| 0x3<br>00B          | 0x<br>00              | <a href="#">I2C_UART_CRC3[7:0]</a> | MSGCNTR_LSB[7:0]                 |                               |                      |                           |                   |               |                                |                                |
| 0x3<br>00<br>C      | 0x<br>00              | <a href="#">I2C_UART_CRC4[7:0]</a> | MSGCNTR_MSB[7:0]                 |                               |                      |                           |                   |               |                                |                                |
| 0x3<br>00<br>D      | 0x<br>00              | <a href="#">I2C_UART_CRC5[7:0]</a> | CRC_ERR_CNT[7:0]                 |                               |                      |                           |                   |               |                                |                                |
| 0x3<br>00E          | 0x<br>00              | <a href="#">I2C_UART_CRC6[7:0]</a> | MSGCNTR_ERR_CNT[7:0]             |                               |                      |                           |                   |               |                                |                                |
| 0x3<br>00F          | 0x<br>06              | <a href="#">I2C_UART_CRC7[7:0]</a> | -                                | -                             | -                    | MSGCNTR_PORT_SEL[1:<br>0] | CC_MSGCNT<br>R_EN | CC_CRC_E<br>N | CC_CRC_<br>MSGCNTR<br>_OVR     |                                |
| 0x3<br>010          | 0x<br>E2              | <a href="#">FS_INTR0[7:0]</a>      | I2C_UART_<br>MSGCNTR_<br>ERR_OEN | I2C_UART_<br>_CRC_ER<br>R_OEN | MEM_ECC_E<br>RR2_OEN | MEM_ECC_<br>ERR1_OEN      | -                 | -             | EFUSE_CR<br>C_ERR_OE<br>N      | REG_CRC<br>_ERR_OEN            |
| 0x3<br>011          | 0x<br>00              | <a href="#">FS_INTR1[7:0]</a>      | I2C_UART_<br>MSGCNTR_<br>ERR_INT | I2C_UART_<br>_CRC_ER<br>R_INT | MEM_ECC_E<br>RR2_INT | MEM_ECC_<br>ERR1_INT      | -                 | -             | EFUSE_CR<br>C_ERR_FL<br>A_G    | REG_CRC<br>_ERR_FL<br>A_G      |
| 0x3<br>016          | 0x<br>00              | <a href="#">MEM_ECC0[7:0]</a>      | MEM_ECC_ERR2_THR[2:0]            |                               |                      | MEM_ECC_ERR1_THR[2:0]     |                   |               | RESET_ME<br>M_ECC_ER<br>R2_CNT | RESET_ME<br>M_ECC_E<br>RR1_CNT |

| AD<br>DR<br>ES<br>S | R<br>E<br>S<br>E<br>T | NAME                           | MSB                   |                           |                       |   |   |   |                    | LSB                |
|---------------------|-----------------------|--------------------------------|-----------------------|---------------------------|-----------------------|---|---|---|--------------------|--------------------|
| 0x3<br>017          | 0x<br>00              | <a href="#">MEM_ECC1[7:0]</a>  | MEM_ECC_ERR1_CNT[7:0] |                           |                       |   |   |   |                    |                    |
| 0x3<br>018          | 0x<br>00              | <a href="#">MEM_ECC2[7:0]</a>  | MEM_ECC_ERR2_CNT[7:0] |                           |                       |   |   |   |                    |                    |
| 0x3<br>020          | 0x<br>00              | <a href="#">REG_POST0[7:0]</a> | POST_DON<br>E         | POST_MB<br>IST_PASS<br>ED | POST_LBIST<br>_PASSED | - | - | - | POST_RUN<br>_MBIST | POST_RU<br>N_LBIST |
| 0x3<br>030          | 0x<br>FF              | <a href="#">REGCRC8[7:0]</a>   | SKIP0_LSB[7:0]        |                           |                       |   |   |   |                    |                    |
| 0x3<br>031          | 0x<br>FF              | <a href="#">REGCRC9[7:0]</a>   | SKIP0_MSB[7:0]        |                           |                       |   |   |   |                    |                    |
| 0x3<br>032          | 0x<br>FF              | <a href="#">REGCRC10[7:0]</a>  | SKIP1_LSB[7:0]        |                           |                       |   |   |   |                    |                    |
| 0x3<br>033          | 0x<br>FF              | <a href="#">REGCRC11[7:0]</a>  | SKIP1_MSB[7:0]        |                           |                       |   |   |   |                    |                    |
| 0x3<br>034          | 0x<br>FF              | <a href="#">REGCRC12[7:0]</a>  | SKIP2_LSB[7:0]        |                           |                       |   |   |   |                    |                    |
| 0x3<br>035          | 0x<br>FF              | <a href="#">REGCRC13[7:0]</a>  | SKIP2_MSB[7:0]        |                           |                       |   |   |   |                    |                    |
| 0x3<br>036          | 0x<br>FF              | <a href="#">REGCRC14[7:0]</a>  | SKIP3_LSB[7:0]        |                           |                       |   |   |   |                    |                    |
| 0x3<br>037          | 0x<br>FF              | <a href="#">REGCRC15[7:0]</a>  | SKIP3_MSB[7:0]        |                           |                       |   |   |   |                    |                    |
| 0x3<br>038          | 0x<br>FF              | <a href="#">REGCRC16[7:0]</a>  | SKIP4_LSB[7:0]        |                           |                       |   |   |   |                    |                    |
| 0x3<br>039          | 0x<br>FF              | <a href="#">REGCRC17[7:0]</a>  | SKIP4_MSB[7:0]        |                           |                       |   |   |   |                    |                    |
| 0x3<br>03A          | 0x<br>FF              | <a href="#">REGCRC18[7:0]</a>  | SKIP5_LSB[7:0]        |                           |                       |   |   |   |                    |                    |
| 0x3<br>03B          | 0x<br>FF              | <a href="#">REGCRC19[7:0]</a>  | SKIP5_MSB[7:0]        |                           |                       |   |   |   |                    |                    |

| ADDRESS          | RESET | NAME                             | MSB                |                    |                   |                  |               |                     |                        | LSB                  |
|------------------|-------|----------------------------------|--------------------|--------------------|-------------------|------------------|---------------|---------------------|------------------------|----------------------|
| 0x303C           | 0xFF  | <a href="#">REGCRC20[7:0]</a>    | SKIP6_LSB[7:0]     |                    |                   |                  |               |                     |                        |                      |
| 0x303D           | 0xFF  | <a href="#">REGCRC21[7:0]</a>    | SKIP6_MSB[7:0]     |                    |                   |                  |               |                     |                        |                      |
| 0x303E           | 0xFF  | <a href="#">REGCRC22[7:0]</a>    | SKIP7_LSB[7:0]     |                    |                   |                  |               |                     |                        |                      |
| 0x303F           | 0xFF  | <a href="#">REGCRC23[7:0]</a>    | SKIP7_MSB[7:0]     |                    |                   |                  |               |                     |                        |                      |
| 0x304F           | 0x00  | <a href="#">CC RTTN ERR[7:0]</a> | -                  | -                  | -                 | -                | -             | RESET_EFUSE_CRC_ERR | INJECT_EFUSE_CRC_ERR   | INJECT_RT TN_CRC_ERR |
| <b>TCTRL_EXT</b> |       |                                  |                    |                    |                   |                  |               |                     |                        |                      |
| 0x5009           | 0x00  | <a href="#">CTRL9[7:0]</a>       | -                  | -                  | -                 | -                | LOCKED_B      | -                   | -                      | -                    |
| 0x5010           | 0x88  | <a href="#">INTR10[7:0]</a>      | RTTN_CRC_ERR_OEN   | IDLE_ERR_OEN_B     | FEC_RX_ERR_OEN_B  | VDD18_OV_OEN     | MAX_RT_OEN_B  | RT_CNT_OEN_B        | PKT_CNT_OEN_B          | VDD_OV_OEN           |
| 0x5011           | 0x00  | <a href="#">INTR11[7:0]</a>      | RTTN_CRC_INT       | IDLE_ERR_FLAG_B    | FEC_RX_ERR_FLAG_B | VDD18_OV_FLAG    | MAX_RT_FLAG_B | RT_CNT_FLAG_B       | PKT_CNT_FLAG_B         | VDD_OV_FLAG          |
| 0x5012           | 0x00  | <a href="#">INTR13[7:0]</a>      | FEC_B_INACTIVE_OEN | FEC_A_INACTIVE_OEN | -                 | -                | -             | -                   | video_mem_overflow_oen | LOSS_OF_LOCK_OEN     |
| 0x5013           | 0x00  | <a href="#">INTR14[7:0]</a>      | FEC_B_INACTIVE     | FEC_A_INACTIVE     | -                 | -                | -             | -                   | video_mem_overflow     | LOSS_OF_LOCK_FLAG    |
| 0x5018           | 0x1F  | <a href="#">INTR12[7:0]</a>      | -                  | -                  | -                 | ERR_RX_ID_B[4:0] |               |                     |                        |                      |
| 0x5024           | 0x00  | <a href="#">CNT2[7:0]</a>        | IDLE_ERR_B[7:0]    |                    |                   |                  |               |                     |                        |                      |
| 0x5025           | 0x00  | <a href="#">CNT3[7:0]</a>        | PKT_CNT_B[7:0]     |                    |                   |                  |               |                     |                        |                      |
| OVERLAP          |       |                                  |                    |                    |                   |                  |               |                     |                        |                      |

| AD<br>DR<br>ES<br>S   | R<br>E<br>S<br>E<br>T | NAME                                 | MSB               |   |                    |                    |                  |   |               | LSB                            |
|-----------------------|-----------------------|--------------------------------------|-------------------|---|--------------------|--------------------|------------------|---|---------------|--------------------------------|
| <b>VID_RX_EXT Y</b>   |                       |                                      |                   |   |                    |                    |                  |   |               |                                |
| 0x5<br>01A            | 0x<br>00              | <a href="#">VIDEO_RX1<br/>3[7:0]</a> | -                 | - | -                  | -                  | -                | - | -             | LOSS_OF_<br>VIDEO_LO<br>CK_OEN |
| 0x5<br>01B            | 0x<br>00              | <a href="#">VIDEO_RX1<br/>4[7:0]</a> | -                 | - | -                  | -                  | -                | - | -             | LOSS_OF_<br>VIDEO_LO<br>CK     |
| <b>VID_RX_EXT Z</b>   |                       |                                      |                   |   |                    |                    |                  |   |               |                                |
| 0x5<br>020            | 0x<br>00              | <a href="#">VIDEO_RX1<br/>3[7:0]</a> | -                 | - | -                  | -                  | -                | - | -             | LOSS_OF_<br>VIDEO_LO<br>CK_OEN |
| 0x5<br>021            | 0x<br>00              | <a href="#">VIDEO_RX1<br/>4[7:0]</a> | -                 | - | -                  | -                  | -                | - | -             | LOSS_OF_<br>VIDEO_LO<br>CK     |
| <b>GMSL B</b>         |                       |                                      |                   |   |                    |                    |                  |   |               |                                |
| 0x5<br>028            | 0x<br>60              | <a href="#">TX0[7:0]</a>             | -                 | - | -                  | -                  | -                | - | RX_FEC_E<br>N | -                              |
| 0x5<br>029            | 0x<br>08              | <a href="#">TX1[7:0]</a>             | LINK_PRBS<br>_GEN | - | -                  | ERRG_EN_<br>B      | -                | - | -             | -                              |
| 0x5<br>02A            | 0x<br>20              | <a href="#">TX2[7:0]</a>             | ERRG_CNT[1:0]     |   | ERRG_RATE[1:0]     |                    | ERRG_BURST[2:0]  |   |               | ERRG_PE<br>R                   |
| 0x5<br>02B            | 0x<br>44              | <a href="#">TX3[7:0]</a>             | -                 | - | RX_FEC_AC<br>TIVE  | -                  | -                | - | -             | -                              |
| 0x5<br>02<br>C        | 0x<br>00              | <a href="#">RX0[7:0]</a>             | PKT_CNT_LBW[1:0]  |   | -                  | -                  | PKT_CNT_SEL[3:0] |   |               |                                |
| 0x5<br>030            | 0x<br>41              | <a href="#">GPIOA[7:0]</a>           | -                 | - | GPIO_FWD_CDLY[5:0] |                    |                  |   |               |                                |
| 0x5<br>031            | 0x<br>88              | <a href="#">GPIOB[7:0]</a>           | GPIO_TX_WNDW[1:0] |   |                    | GPIO_REV_CDLY[5:0] |                  |   |               |                                |
| <b>CFGH_B VIDEO_X</b> |                       |                                      |                   |   |                    |                    |                  |   |               |                                |
| 0x5<br>050            | 0x<br>00              | <a href="#">RX0[7:0]</a>             | RX_CRC_E<br>N_B   | - | -                  | -                  | -                | - | -             | STR_SEL_B[1:0]                 |

| AD<br>DR<br>ES<br>S   | R<br>E<br>S<br>E<br>T | NAME                      | MSB               |                 |               |   |                 |                        |                      | LSB              |
|-----------------------|-----------------------|---------------------------|-------------------|-----------------|---------------|---|-----------------|------------------------|----------------------|------------------|
| <b>CFGH_B VIDEO_Y</b> |                       |                           |                   |                 |               |   |                 |                        |                      |                  |
| 0x5<br>051            | 0x<br>01              | <a href="#">RX0[7:0]</a>  | RX_CRC_E<br>N_B   | -               | -             | - | -               | -                      | STR_SEL_B[1:0]       |                  |
| <b>CFGH_B VIDEO_Z</b> |                       |                           |                   |                 |               |   |                 |                        |                      |                  |
| 0x5<br>052            | 0x<br>02              | <a href="#">RX0[7:0]</a>  | RX_CRC_E<br>N_B   | -               | -             | - | -               | -                      | STR_SEL_B[1:0]       |                  |
| <b>CFGH_B VIDEO_U</b> |                       |                           |                   |                 |               |   |                 |                        |                      |                  |
| 0x5<br>053            | 0x<br>03              | <a href="#">RX0[7:0]</a>  | RX_CRC_E<br>N_B   | -               | -             | - | -               | -                      | STR_SEL_B[1:0]       |                  |
| <b>CFGH_B INFOFR</b>  |                       |                           |                   |                 |               |   |                 |                        |                      |                  |
| 0x5<br>060            | 0x<br>F0              | <a href="#">TR0[7:0]</a>  | TX_CRC_E<br>N_B   | RX_CRC_<br>EN_B | -             | - | PRIO_VAL_B[1:0] |                        | PRIO_CFG_B[1:0]      |                  |
| 0x5<br>061            | 0x<br>B0              | <a href="#">TR1[7:0]</a>  | BW_MULT_B[1:0]    |                 | BW_VAL_B[5:0] |   |                 |                        |                      |                  |
| 0x5<br>063            | 0x<br>00              | <a href="#">TR3[7:0]</a>  | -                 | -               | -             | - | -               | TX_SRC_ID_B[2:0]       |                      |                  |
| 0x5<br>064            | 0x<br>FF              | <a href="#">TR4[7:0]</a>  | RX_SRC_SEL_B[7:0] |                 |               |   |                 |                        |                      |                  |
| <b>CFGH_B CC</b>      |                       |                           |                   |                 |               |   |                 |                        |                      |                  |
| 0x5<br>070            | 0x<br>F0              | <a href="#">TR0[7:0]</a>  | TX_CRC_E<br>N_B   | RX_CRC_<br>EN_B | -             | - | PRIO_VAL_B[1:0] |                        | PRIO_CFG_B[1:0]      |                  |
| 0x5<br>071            | 0x<br>B0              | <a href="#">TR1[7:0]</a>  | BW_MULT_B[1:0]    |                 | BW_VAL_B[5:0] |   |                 |                        |                      |                  |
| 0x5<br>073            | 0x<br>00              | <a href="#">TR3[7:0]</a>  | -                 | -               | -             | - | -               | TX_SRC_ID_B[2:0]       |                      |                  |
| 0x5<br>074            | 0x<br>FF              | <a href="#">TR4[7:0]</a>  | RX_SRC_SEL_B[7:0] |                 |               |   |                 |                        |                      |                  |
| 0x5<br>075            | 0x<br>98              | <a href="#">ARQ0[7:0]</a> | -                 | -               | -             | - | EN_B            | DIS_DBL_ACK<br>_RETX_B | -                    | -                |
| 0x5<br>076            | 0x<br>72              | <a href="#">ARQ1[7:0]</a> | -                 | -               | -             | - | -               | -                      | MAX_RT_E<br>RR_OEN_B | RT_CNT_O<br>EN_B |

| AD<br>DR<br>ES<br>S  | R<br>E<br>S<br>E<br>T | NAME                      | MSB               |                 |               |   |                 |                        |                      | LSB              |  |
|----------------------|-----------------------|---------------------------|-------------------|-----------------|---------------|---|-----------------|------------------------|----------------------|------------------|--|
| 0x5<br>077           | 0x<br>00              | <a href="#">ARQ2[7:0]</a> | MAX_RT_E<br>RR_B  | RT_CNT_B[6:0]   |               |   |                 |                        |                      |                  |  |
| <b>CFGL_B GPIO</b>   |                       |                           |                   |                 |               |   |                 |                        |                      |                  |  |
| 0x5<br>078           | 0x<br>F0              | <a href="#">TR0[7:0]</a>  | TX_CRC_E<br>N_B   | RX_CRC_<br>EN_B | -             | - | PRIO_VAL_B[1:0] | PRIO_CFG_B[1:0]        |                      |                  |  |
| 0x5<br>079           | 0x<br>B0              | <a href="#">TR1[7:0]</a>  | BW_MULT_B[1:0]    |                 | BW_VAL_B[5:0] |   |                 |                        |                      |                  |  |
| 0x5<br>07B           | 0x<br>00              | <a href="#">TR3[7:0]</a>  | -                 | -               | -             | - | -               | TX_SRC_ID_B[2:0]       |                      |                  |  |
| 0x5<br>07C           | 0x<br>FF              | <a href="#">TR4[7:0]</a>  | RX_SRC_SEL_B[7:0] |                 |               |   |                 |                        |                      |                  |  |
| 0x5<br>07D           | 0x<br>98              | <a href="#">ARQ0[7:0]</a> | -                 | -               | -             | - | EN_B            | DIS_DBL_ACK<br>_RETX_B | -                    | -                |  |
| 0x5<br>07E           | 0x<br>72              | <a href="#">ARQ1[7:0]</a> | -                 | -               | -             | - | -               | -                      | MAX_RT_E<br>RR_OEN_B | RT_CNT_O<br>EN_B |  |
| 0x5<br>07F           | 0x<br>00              | <a href="#">ARQ2[7:0]</a> | MAX_RT_E<br>RR_B  | RT_CNT_B[6:0]   |               |   |                 |                        |                      |                  |  |
| <b>CFG_C_B IIC_X</b> |                       |                           |                   |                 |               |   |                 |                        |                      |                  |  |
| 0x5<br>080           | 0x<br>F0              | <a href="#">TR0[7:0]</a>  | TX_CRC_E<br>N_B   | RX_CRC_<br>EN_B | -             | - | PRIO_VAL_B[1:0] | PRIO_CFG_B[1:0]        |                      |                  |  |
| 0x5<br>081           | 0x<br>B0              | <a href="#">TR1[7:0]</a>  | BW_MULT_B[1:0]    |                 | BW_VAL_B[5:0] |   |                 |                        |                      |                  |  |
| 0x5<br>083           | 0x<br>00              | <a href="#">TR3[7:0]</a>  | -                 | -               | -             | - | -               | TX_SRC_ID_B[2:0]       |                      |                  |  |
| 0x5<br>084           | 0x<br>FF              | <a href="#">TR4[7:0]</a>  | RX_SRC_SEL_B[7:0] |                 |               |   |                 |                        |                      |                  |  |
| 0x5<br>085           | 0x<br>98              | <a href="#">ARQ0[7:0]</a> | -                 | -               | -             | - | EN_B            | DIS_DBL_ACK<br>_RETX_B | -                    | -                |  |
| 0x5<br>086           | 0x<br>72              | <a href="#">ARQ1[7:0]</a> | -                 | -               | -             | - | -               | -                      | MAX_RT_E<br>RR_OEN_B | RT_CNT_O<br>EN_B |  |

| AD DR ES S           | R E S E T | NAME                        | MSB               |                   |                  |                   |                 |                        |                      | LSB              |  |
|----------------------|-----------|-----------------------------|-------------------|-------------------|------------------|-------------------|-----------------|------------------------|----------------------|------------------|--|
| 0x5087               | 0x00      | <a href="#">ARQ2[7:0]</a>   | MAX_RT_E<br>RR_B  | RT_CNT_B[6:0]     |                  |                   |                 |                        |                      |                  |  |
| <b>CFG_C_B IIC_Y</b> |           |                             |                   |                   |                  |                   |                 |                        |                      |                  |  |
| 0x5088               | 0xF0      | <a href="#">TR0[7:0]</a>    | TX_CRC_E<br>N_B   | RX_CRC_<br>EN_B   | -                | -                 | PRIO_VAL_B[1:0] | PRIO_CFG_B[1:0]        |                      |                  |  |
| 0x5089               | 0xB0      | <a href="#">TR1[7:0]</a>    | BW_MULT_B[1:0]    |                   | BW_VAL_B[5:0]    |                   |                 |                        |                      |                  |  |
| 0x508B               | 0x00      | <a href="#">TR3[7:0]</a>    | -                 | -                 | -                | -                 | -               | TX_SRC_ID_B[2:0]       |                      |                  |  |
| 0x508C               | 0xFF      | <a href="#">TR4[7:0]</a>    | RX_SRC_SEL_B[7:0] |                   |                  |                   |                 |                        |                      |                  |  |
| 0x508D               | 0x98      | <a href="#">ARQ0[7:0]</a>   | -                 | -                 | -                | -                 | EN_B            | DIS_DBL_ACK<br>_RETX_B | -                    | -                |  |
| 0x508E               | 0x72      | <a href="#">ARQ1[7:0]</a>   | -                 | -                 | -                | -                 | -               | -                      | MAX_RT_E<br>RR_OEN_B | RT_CNT_O<br>EN_B |  |
| 0x508F               | 0x00      | <a href="#">ARQ2[7:0]</a>   | MAX_RT_E<br>RR_B  | RT_CNT_B[6:0]     |                  |                   |                 |                        |                      |                  |  |
| <b>GPIO0_B 0</b>     |           |                             |                   |                   |                  |                   |                 |                        |                      |                  |  |
| 0x52B0               | 0x02      | <a href="#">GPIO_A[7:0]</a> | -                 | -                 | TX_COMP_E<br>N_B | -                 | -               | GPIO_RX_EN<br>_B       | GPIO_TX_E<br>N_B     | -                |  |
| 0x52B1               | 0x00      | <a href="#">GPIO_B[7:0]</a> | -                 | -                 | -                | GPIO_TX_ID_B[4:0] |                 |                        |                      |                  |  |
| 0x52B2               | 0x40      | <a href="#">GPIO_C[7:0]</a> | -                 | GPIO_RE<br>CVED_B | -                | GPIO_RX_ID_B[4:0] |                 |                        |                      |                  |  |
| <b>GPIO0_B 1</b>     |           |                             |                   |                   |                  |                   |                 |                        |                      |                  |  |
| 0x52B3               | 0x00      | <a href="#">GPIO_A[7:0]</a> | -                 | -                 | TX_COMP_E<br>N_B | -                 | -               | GPIO_RX_EN<br>_B       | GPIO_TX_E<br>N_B     | -                |  |
| 0x52B4               | 0x01      | <a href="#">GPIO_B[7:0]</a> | -                 | -                 | -                | GPIO_TX_ID_B[4:0] |                 |                        |                      |                  |  |

| AD DR ES S       | R E S E T | NAME                        | MSB |   |                  |                   |   |                  |                  | LSB |
|------------------|-----------|-----------------------------|-----|---|------------------|-------------------|---|------------------|------------------|-----|
| 0x5<br>2B5       | 0x<br>41  | <a href="#">GPIO_C[7:0]</a> | -   | - | -                | GPIO_RX_ID_B[4:0] |   |                  |                  |     |
| <b>GPIO0_B 2</b> |           |                             |     |   |                  |                   |   |                  |                  |     |
| 0x5<br>2B6       | 0x<br>00  | <a href="#">GPIO_A[7:0]</a> | -   | - | TX_COMP_E<br>N_B | -                 | - | GPIO_RX_EN<br>_B | GPIO_TX_E<br>N_B | -   |
| 0x5<br>2B7       | 0x<br>02  | <a href="#">GPIO_B[7:0]</a> | -   | - | -                | GPIO_TX_ID_B[4:0] |   |                  |                  |     |
| 0x5<br>2B8       | 0x<br>42  | <a href="#">GPIO_C[7:0]</a> | -   | - | -                | GPIO_RX_ID_B[4:0] |   |                  |                  |     |
| <b>GPIO0_B 3</b> |           |                             |     |   |                  |                   |   |                  |                  |     |
| 0x5<br>2B9       | 0x<br>00  | <a href="#">GPIO_A[7:0]</a> | -   | - | TX_COMP_E<br>N_B | -                 | - | GPIO_RX_EN<br>_B | GPIO_TX_E<br>N_B | -   |
| 0x5<br>2B<br>A   | 0x<br>03  | <a href="#">GPIO_B[7:0]</a> | -   | - | -                | GPIO_TX_ID_B[4:0] |   |                  |                  |     |
| 0x5<br>2B<br>B   | 0x<br>43  | <a href="#">GPIO_C[7:0]</a> | -   | - | -                | GPIO_RX_ID_B[4:0] |   |                  |                  |     |
| <b>GPIO0_B 4</b> |           |                             |     |   |                  |                   |   |                  |                  |     |
| 0x5<br>2B<br>C   | 0x<br>00  | <a href="#">GPIO_A[7:0]</a> | -   | - | TX_COMP_E<br>N_B | -                 | - | GPIO_RX_EN<br>_B | GPIO_TX_E<br>N_B | -   |
| 0x5<br>2B<br>D   | 0x<br>04  | <a href="#">GPIO_B[7:0]</a> | -   | - | -                | GPIO_TX_ID_B[4:0] |   |                  |                  |     |
| 0x5<br>2B<br>E   | 0x<br>44  | <a href="#">GPIO_C[7:0]</a> | -   | - | -                | GPIO_RX_ID_B[4:0] |   |                  |                  |     |
| <b>GPIO0_B 5</b> |           |                             |     |   |                  |                   |   |                  |                  |     |
| 0x5<br>2B<br>F   | 0x<br>00  | <a href="#">GPIO_A[7:0]</a> | -   | - | TX_COMP_E<br>N_B | -                 | - | GPIO_RX_EN<br>_B | GPIO_TX_E<br>N_B | -   |

| AD DR ES S       | R E S E T | NAME                        | MSB |   |                  |   |   |                   |                  | LSB |
|------------------|-----------|-----------------------------|-----|---|------------------|---|---|-------------------|------------------|-----|
| 0x5<br>2C<br>0   | 0x<br>05  | <a href="#">GPIO_B[7:0]</a> | -   | - | -                |   |   | GPIO_TX_ID_B[4:0] |                  |     |
| 0x5<br>2C<br>1   | 0x<br>45  | <a href="#">GPIO_C[7:0]</a> | -   | - | -                |   |   | GPIO_RX_ID_B[4:0] |                  |     |
| <b>GPIO0_B 6</b> |           |                             |     |   |                  |   |   |                   |                  |     |
| 0x5<br>2C<br>2   | 0x<br>02  | <a href="#">GPIO_A[7:0]</a> | -   | - | TX_COMP_E<br>N_B | - | - | GPIO_RX_EN<br>_B  | GPIO_TX_E<br>N_B | -   |
| 0x5<br>2C<br>3   | 0x<br>06  | <a href="#">GPIO_B[7:0]</a> | -   | - | -                |   |   | GPIO_TX_ID_B[4:0] |                  |     |
| 0x5<br>2C<br>4   | 0x<br>46  | <a href="#">GPIO_C[7:0]</a> | -   | - | -                |   |   | GPIO_RX_ID_B[4:0] |                  |     |
| <b>GPIO0_B 7</b> |           |                             |     |   |                  |   |   |                   |                  |     |
| 0x5<br>2C<br>5   | 0x<br>00  | <a href="#">GPIO_A[7:0]</a> | -   | - | TX_COMP_E<br>N_B | - | - | GPIO_RX_EN<br>_B  | GPIO_TX_E<br>N_B | -   |
| 0x5<br>2C<br>6   | 0x<br>07  | <a href="#">GPIO_B[7:0]</a> | -   | - | -                |   |   | GPIO_TX_ID_B[4:0] |                  |     |
| 0x5<br>2C<br>7   | 0x<br>47  | <a href="#">GPIO_C[7:0]</a> | -   | - | -                |   |   | GPIO_RX_ID_B[4:0] |                  |     |
| <b>GPIO0_B 8</b> |           |                             |     |   |                  |   |   |                   |                  |     |
| 0x5<br>2C<br>8   | 0x<br>00  | <a href="#">GPIO_A[7:0]</a> | -   | - | TX_COMP_E<br>N_B | - | - | GPIO_RX_EN<br>_B  | GPIO_TX_E<br>N_B | -   |
| 0x5<br>2C<br>9   | 0x<br>08  | <a href="#">GPIO_B[7:0]</a> | -   | - | -                |   |   | GPIO_TX_ID_B[4:0] |                  |     |

| AD<br>DR<br>ES<br>S | R<br>E<br>S<br>E<br>T | NAME                        | MSB |   |                  |                   |   |                  |                  | LSB |
|---------------------|-----------------------|-----------------------------|-----|---|------------------|-------------------|---|------------------|------------------|-----|
| 0x5<br>2C<br>A      | 0x<br>48              | <a href="#">GPIO_C[7:0]</a> | -   | - | -                | GPIO_RX_ID_B[4:0] |   |                  |                  |     |
| <b>GPIO0_B 9</b>    |                       |                             |     |   |                  |                   |   |                  |                  |     |
| 0x5<br>2C<br>B      | 0x<br>00              | <a href="#">GPIO_A[7:0]</a> | -   | - | TX_COMP_E<br>N_B | -                 | - | GPIO_RX_EN<br>_B | GPIO_TX_E<br>N_B | -   |
| 0x5<br>2C<br>C      | 0x<br>09              | <a href="#">GPIO_B[7:0]</a> | -   | - | -                | GPIO_TX_ID_B[4:0] |   |                  |                  |     |
| 0x5<br>2C<br>D      | 0x<br>49              | <a href="#">GPIO_C[7:0]</a> | -   | - | -                | GPIO_RX_ID_B[4:0] |   |                  |                  |     |
| <b>GPIO0_B 10</b>   |                       |                             |     |   |                  |                   |   |                  |                  |     |
| 0x5<br>2C<br>E      | 0x<br>00              | <a href="#">GPIO_A[7:0]</a> | -   | - | TX_COMP_E<br>N_B | -                 | - | GPIO_RX_EN<br>_B | GPIO_TX_E<br>N_B | -   |
| 0x5<br>2C<br>F      | 0x<br>0A              | <a href="#">GPIO_B[7:0]</a> | -   | - | -                | GPIO_TX_ID_B[4:0] |   |                  |                  |     |
| 0x5<br>2D<br>0      | 0x<br>4A              | <a href="#">GPIO_C[7:0]</a> | -   | - | -                | GPIO_RX_ID_B[4:0] |   |                  |                  |     |
| <b>GPIO0_B 11</b>   |                       |                             |     |   |                  |                   |   |                  |                  |     |
| 0x5<br>2D<br>1      | 0x<br>00              | <a href="#">GPIO_A[7:0]</a> | -   | - | TX_COMP_E<br>N_B | -                 | - | GPIO_RX_EN<br>_B | GPIO_TX_E<br>N_B | -   |
| 0x5<br>2D<br>2      | 0x<br>0B              | <a href="#">GPIO_B[7:0]</a> | -   | - | -                | GPIO_TX_ID_B[4:0] |   |                  |                  |     |
| 0x5<br>2D<br>3      | 0x<br>4B              | <a href="#">GPIO_C[7:0]</a> | -   | - | -                | GPIO_RX_ID_B[4:0] |   |                  |                  |     |
| <b>GPIO0_B 12</b>   |                       |                             |     |   |                  |                   |   |                  |                  |     |

| ADDRESS | RESET | NAME                        | MSB |   |              |                   |   |              |              | LSB |
|---------|-------|-----------------------------|-----|---|--------------|-------------------|---|--------------|--------------|-----|
| 0x52D4  | 0x00  | <a href="#">GPIO_A[7:0]</a> | -   | - | TX_COMP_EN_B | -                 | - | GPIO_RX_EN_B | GPIO_TX_EN_B | -   |
| 0x52D5  | 0x0C  | <a href="#">GPIO_B[7:0]</a> | -   | - | -            | GPIO_TX_ID_B[4:0] |   |              |              |     |
| 0x52D6  | 0x4C  | <a href="#">GPIO_C[7:0]</a> | -   | - | -            | GPIO_RX_ID_B[4:0] |   |              |              |     |

### Register Details

#### [REG0 \(0x0\)](#)

| BIT         | 7             | 6 | 5 | 4 | 3 | 2 | 1 | 0           |
|-------------|---------------|---|---|---|---|---|---|-------------|
| Field       | DEV_ADDR[6:0] |   |   |   |   |   |   | CFG_BLOCK   |
| Reset       | 0b1001000     |   |   |   |   |   |   | 0b0         |
| Access Type | Write, Read   |   |   |   |   |   |   | Write, Read |

| BITFIELD  | BITS | DESCRIPTION   | DECODE  |
|-----------|------|---|---|
| DEV_ADDR  | 7:1  | Device I <sup>2</sup> C Address<br><br>Default value is set by the CFG0 pin as follows:<br>CFG0    Device Address<br>000    0b0101000<br>001    0b0101010<br>010    0b1001100<br>011    0b1101010<br>100    0b1101010<br>101    0b1001100<br>110    0b0101010<br>111    0b0101000 | 0b0000000: I <sup>2</sup> C write/read address is 0x00/0x01<br>0b0000001: I <sup>2</sup> C write/read address is 0x02/0x03<br>...<br>0b1001000: I <sup>2</sup> C write/read address is 0x90/0x91<br>0b1001010: I <sup>2</sup> C write/read address is 0x94/0x95<br>0b1001100: I <sup>2</sup> C write/read address is 0x98/0x99<br>0b1101000: I <sup>2</sup> C write/read address is 0xD0/0xD1<br>0b1101010: I <sup>2</sup> C write/read address is 0xD4/0xD5<br>0b1101100: I <sup>2</sup> C write/read address is 0xD8/0xD9<br>0b0101000: I <sup>2</sup> C write/read address is 0x50/0x51<br>0b0101010: I <sup>2</sup> C write/read address is 0x54/0x55<br>...<br>0b1111111: I <sup>2</sup> C write/read address is 0xFE/0xFF |
| CFG_BLOCK | 0    | Configuration Block<br><br>When set, all registers become non-writable (read-only). This bit can be used to freeze the chip configuration. The only way to clear this register and regain write access is with a power cycle or toggling the PWDNB pin.                           | 0b0: Not blocked<br>0b1: Blocked  |

**REG1 (0x1)**

| BIT         | 7           | 6           | 5            | 4           | 3            | 2 | 1            | 0 |
|-------------|-------------|-------------|--------------|-------------|--------------|---|--------------|---|
| Field       | IIC_2_EN    | IIC_1_EN    | DIS_LOCAL_CC | DIS_REM_CC  | TX_RATE[1:0] |   | RX_RATE[1:0] |   |
| Reset       | 0b0         | 0b0         | 0b0          | 0b0         | 0b00         |   | 0b10         |   |
| Access Type | Write, Read | Write, Read | Write, Read  | Write, Read | Write, Read  |   | Write, Read  |   |

| BITFIELD     | BITS | DESCRIPTION  | DECODE  |
|--------------|------|--|---|
| IIC_2_EN     | 7    | Enable pass-through I <sup>2</sup> C Channel 2 (SDA2/RX2, SCL2/TX2)  | 0b0: I <sup>2</sup> C pass-through Channel 2 disabled<br>0b1: I <sup>2</sup> C pass-through Channel 2 enabled   |
| IIC_1_EN     | 6    | Enable pass-through I <sup>2</sup> C Channel 1 (SDA1/RX1, SCL1/TX1)  | 0b0: I <sup>2</sup> C pass-through Channel 1 disabled<br>0b1: I <sup>2</sup> C pass-through Channel 1 enabled   |
| DIS_LOCAL_CC | 5    | Disable control channel connection to RX/SDA and TX/SCL pins   | 0b0: RX/SDA and TX/XCL connected to control channel<br>0b1: RX/SDA and TX/SCL disconnected from control channel |
| DIS_REM_CC   | 4    | Disable access to Link A serializer control channel over GMSL2 connection from RX/SDA and TX/SCL pins.   | 0b0: Remote control channel enabled<br>0b1: Remote control channel disabled                                     |
| TX_RATE      | 3:2  | Link A Transmitter Rate<br>When changing this value, restart the link with a write to the RESET_ONESHOT or RESET_LINK register for the new value to take effect.   | 0b00: 187.5Mbps<br>0b01: Reserved<br>0b10: Reserved<br>0b11: Reserved   |
| RX_RATE      | 1:0  | Link A Receiver Rate<br>When changing this value, restart the link with a write to the RESET_ONESHOT or RESET_LINK register for the new value to take effect.<br>Default value is set by configuration pins at power-up. | 0b00: Reserved<br>0b01: 3Gbps<br>0b10: 6Gbps<br>0b11: 12Gbps (applies to GMSL3 capable parts)                   |

**REG2 (0x2)**

| BIT         | 7 | 6           | 5           | 4 | 3 | 2 | 1 | 0 |
|-------------|---|-------------|-------------|---|---|---|---|---|
| Field       | – | VID_EN_Z    | VID_EN_Y    | – | – | – | – | – |
| Reset       | – | 0b1         | 0b1         | – | – | – | – | – |
| Access Type | – | Write, Read | Write, Read | – | – | – | – | – |

| BITFIELD | BITS | DESCRIPTION                                   | DECODE  |
|----------|------|---|---|
| VID_EN_Z | 6    | Enable data transmission through video pipe Z | 0b0: Video pipe Z disabled<br>0b1: Video pipe Z enabled |
| VID_EN_Y | 5    | Enable data transmission through video pipe Y | 0b0: Video pipe Y disabled<br>0b1: Video pipe Y enabled |

**REG3 (0x3)**

| BIT         | 7           | 6           | 5           | 4           | 3 | 2            | 1 | 0 |
|-------------|-------------|-------------|-------------|-------------|---|--------------|---|---|
| Field       | LOCK_CFG    | PT_SWAP     | UART_2_EN   | UART_1_EN   | – | DIS_REM_CC_B | – | – |
| Reset       | 0b0         | 0b1         | 0b0         | 0b1         | – | 0b0          | – | – |
| Access Type | Write, Read | Write, Read | Write, Read | Write, Read | – | Write, Read  | – | – |

| BITFIELD     | BITS | DESCRIPTION  | DECODE  |
|--------------|------|--|---|
| LOCK_CFG     | 7    | Configure LOCK pin behavior  | 0b0: GMSL2 link locked<br>0b1: GMSL2 link locked and MIPI output started              |
| PT_SWAP      | 6    | Swap I <sup>2</sup> C/UART pass-through 1 pin assignments with pass-through 2 pin assignments. Swaps SDA1_RX1 (MFP0) with SDA2_RX2 (MFP5), and SCL1_TX1 (MFP1) with SCL2_TX2 (MFP6). | 0b0: Do not swap pin assignments<br>0b1: Swap pin assignments                         |
| UART_2_EN    | 5    | Enable pass-through UART Channel 2 (SDA2/RX2, SCL2/TX2) (MFP5/6)   | 0b0: Pass-through UART Channel 2 disabled<br>0b1: Pass-through UART Channel 2 enabled |
| UART_1_EN    | 4    | Enable pass-through UART Channel 1 (SDA1/RX1, SCL1/TX1) (MFP0/1)   | 0b0: Pass-through UART Channel 1 disabled<br>0b1: Pass-through UART Channel 1 enabled |
| DIS_REM_CC_B | 2    | Disable access to Link B serializer control channel over GMSL2 connection from RX/SDA and TX/SCL pins  | 0b0: Remote control channel enabled<br>0b1: Remote control channel disabled           |

**REG4 (0x4)**

| BIT         | 7           | 6           | 5 | 4 | 3              | 2 | 1              | 0 |
|-------------|-------------|-------------|---|---|----------------|---|----------------|---|
| Field       | GMSL3_B     | GMSL3_A     | – | – | TX_RATE_B[1:0] |   | RX_RATE_B[1:0] |   |
| Reset       | 0b1         | 0b1         | – | – | 0b00           |   | 0b10           |   |
| Access Type | Write, Read | Write, Read | – | – | Write, Read    |   | Write, Read    |   |

| BITFIELD  | BITS | DESCRIPTION   | DECODE  |
|-----------|------|---|---|
| GMSL3_B   | 7    | GMSL3 or 2 selection for Link B. Bit is set according to the latched CFG pin value at power-up. When changing this value, restart the link with a write to the RESET_ONESHOT or RESET_LINK register for the new value to take effect. | 0x0: GMSL2<br>0x1: GMSL3  |
| GMSL3_A   | 6    | GMSL3 or 2 selection for Link A. Bit is set according to the latched CFG pin value at power-up. When changing this value, restart the link with a write to the RESET_ONESHOT or RESET_LINK register for the new value to take effect. | 0x0: GMSL2<br>0x1: GMSL3  |
| TX_RATE_B | 3:2  | Link B Transmitter Rate<br>When changing this value, restart the link with a write to the RESET_ONESHOT or RESET_LINK register for the new value to take effect.  | 0b00: 187.5Mbps<br>0b01: Reserved<br>0b10: Reserved<br>0b11: Reserved |
| RX_RATE_B | 1:0  | Link B Receiver Rate<br>When changing this value, restart the link with a   | 0b00: Reserved<br>0b01: 3Gbps   |

| BITFIELD | BITS | DESCRIPTION   | DECODE   |
|----------|------|---|--|
|          |      | write to the RESET_ONESHOT or RESET_LINK register for the new value to take effect. Default value is set by configuration pins at power-up. | 0b10: 6Gbps<br>0b11: 12Gbps (applies to GMSL3 capable parts) |

**REG5 (0x5)**

| BIT         | 7           | 6           | 5           | 4 | 3           | 2           | 1           | 0           |
|-------------|-------------|-------------|-------------|---|-------------|-------------|-------------|-------------|
| Field       | LOCK_EN     | ERRB_EN     | LOCK_ALT_EN | – | PU_LF3      | PU_LF2      | PU_LF1      | PU_LF0      |
| Reset       | 0b1         | 0b1         | 0b0         | – | 0b0         | 0b0         | 0b0         | 0b0         |
| Access Type | Write, Read | Write, Read | Write, Read | – | Write, Read | Write, Read | Write, Read | Write, Read |

| BITFIELD    | BITS | DESCRIPTION                   | DECODE  |
|-------------|------|-------------------------------|---|
| LOCK_EN     | 7    | Enable LOCK output            | 0b0: LOCK output disabled<br>0b1: LOCK output enabled                   |
| ERRB_EN     | 6    | Enable ERRB output            | 0b0: ERRB output disabled<br>0b1: ERRB output enabled                   |
| LOCK_ALT_EN | 5    | Enable LOCK alternate output  | 0b0: LOCK output disabled<br>0b1: LOCK output enabled                   |
| PU_LF3      | 3    | Power up line-fault monitor 3 | 0b0: Line-fault monitor 3 disabled<br>0b1: Line-fault monitor 3 enabled |
| PU_LF2      | 2    | Power up line-fault monitor 2 | 0b0: Line-fault monitor 2 disabled<br>0b1: Line-fault monitor 2 enabled |
| PU_LF1      | 1    | Power up line-fault monitor 1 | 0b0: Line-fault monitor 1 disabled<br>0b1: Line-fault monitor 1 enabled |
| PU_LF0      | 0    | Power up line-fault monitor 0 | 0b0: Line-fault monitor 0 disabled<br>0b1: Line-fault monitor 0 enabled |

**REG6 (0x6)**

| BIT         | 7           | 6           | 5              | 4           | 3 | 2 | 1 | 0 |
|-------------|-------------|-------------|----------------|-------------|---|---|---|---|
| Field       | GMSL2_B     | GMSL2_A     | DIS_REM_CC_2_B | I2CSEL      | – | – | – | – |
| Reset       | 0b1         | 0b1         | 0b0            | 0b0         | – | – | – | – |
| Access Type | Write, Read | Write, Read | Write, Read    | Write, Read | – | – | – | – |

| BITFIELD | BITS | DESCRIPTION   | DECODE                   |
|----------|------|---|--------------------------|
| GMSL2_B  | 7    | GMSL1/GMSL2 selection for Link B. Bit is set according to the latched CFG pin value at power-up. When changing this value, restarting the link with a write to the RESET_ONESHOT or RESET_LINK register is required for the new value to take effect. | 0x0: GMSL1<br>0x1: GMSL2 |
| GMSL2_A  | 6    | GMSL1/GMSL2 selection for Link A. Bit is set according to the latched CFG pin value at power-up.  | 0x0: GMSL1<br>0x1: GMSL2 |

| BITFIELD       | BITS | DESCRIPTION  | DECODE  |
|----------------|------|--|---|
|                |      | When changing this value, restarting the link with a write to the RESET_ONESHOT or RESET_LINK register is required for the new value to take effect.   |   |
| DIS_REM_CC_2_B | 5    | Disable access to Link B serializer control channel over GMSL2 connection from I <sup>2</sup> C/UART Channel 1 (SDA2/RX2, SCL2/TX2)  | 0b0: Remote control-channel enabled<br>0b1: Remote control-channel disabled |
| I2CSEL         | 4    | I <sup>2</sup> C/UART selection<br>Bit is set according to the CFG0 pin value at power-up.<br>Changing this value through a register write is not recommended. Instead, change the CFG0 pin voltage and power up the device again. | 0: UART<br>1: I <sup>2</sup> C  |

**REG7 (0x7)**

| BIT         | 7                | 6 | 5 | 4 | 3 | 2 | 1 | 0 |
|-------------|------------------|---|---|---|---|---|---|---|
| Field       | CMP_VTERM_STATUS | – | – | – | – | – | – | – |
| Reset       | 0b0              | – | – | – | – | – | – | – |
| Access Type | Read Only        | – | – | – | – | – | – | – |

| BITFIELD         | BITS | DESCRIPTION  | DECODE  |
|------------------|------|--|---|
| CMP_VTERM_STATUS | 7    | V <sub>TERM</sub> supply undervoltage comparator status<br>Latched low when switched V <sub>TERM</sub> supply < 1V.<br>Cleared when the CMP_STATUS word is read and the switched V <sub>TERM</sub> supply is > 1V. | 0b0: Latched low when V <sub>TERM</sub> < 1V<br>0b1: Latched high when V <sub>TERM</sub> > 1V |

**REG13 (0xD)**

| BIT         | 7           | 6 | 5 | 4 | 3 | 2 | 1 | 0 |
|-------------|-------------|---|---|---|---|---|---|---|
| Field       | DEV_ID[7:0] |   |   |   |   |   |   |   |
| Reset       | 0xB6        |   |   |   |   |   |   |   |
| Access Type | Read Only   |   |   |   |   |   |   |   |

| BITFIELD | BITS | DESCRIPTION       | DECODE         |
|----------|------|-------------------|----------------|
| DEV_ID   | 7:0  | Device Identifier | 0xB: MAX96792A |

**REG14 (0xE)**

| BIT   | 7 | 6 | 5 | 4 | 3            | 2 | 1 | 0 |
|-------|---|---|---|---|--------------|---|---|---|
| Field | – | – | – | – | DEV_REV[3:0] |   |   |   |

|                    |   |   |   |   |           |
|--------------------|---|---|---|---|-----------|
| <b>Reset</b>       | – | – | – | – | 0x3       |
| <b>Access Type</b> | – | – | – | – | Read Only |

| <b>BITFIELD</b> | <b>BITS</b> | <b>DESCRIPTION</b>   | <b>DECODE</b>  |
|-----------------|-------------|--|--|
| DEV_REV         | 3:0         | Device Revision. Refer to the device Errata sheet for correct RESET value. | 0xX: Revision ID number. Refer to errata for specific revision ID. |

**REG15 (0xF)**

| <b>BIT</b>         | <b>7</b> | <b>6</b> | <b>5</b> | <b>4</b> | <b>3</b> | <b>2</b> | <b>1</b> | <b>0</b>   |
|--------------------|----------|----------|----------|----------|----------|----------|----------|------------|
| <b>Field</b>       | –        | –        | –        | –        | –        | –        | –        | GMSL1_CPBL |
| <b>Reset</b>       | –        | –        | –        | –        | –        | –        | –        | 0b0        |
| <b>Access Type</b> | –        | –        | –        | –        | –        | –        | –        | Read Only  |

| <b>BITFIELD</b> | <b>BITS</b> | <b>DESCRIPTION</b>         | <b>DECODE</b>  |
|-----------------|-------------|----------------------------|--|
| GMSL1_CPBL      | 0           | GMSL1 capability indicator | 0b0: Device does not support GMSL1 mode<br>0b1: Device supports GMSL1 mode |

**REG26 (0x26)**

| <b>BIT</b>         | <b>7</b> | <b>6</b>  | <b>5</b> | <b>4</b> | <b>3</b> | <b>2</b>  | <b>1</b> | <b>0</b> |
|--------------------|----------|-----------|----------|----------|----------|-----------|----------|----------|
| <b>Field</b>       | –        | LF_1[2:0] |          |          | –        | LF_0[2:0] |          |          |
| <b>Reset</b>       | –        | 0b010     |          |          | –        | 0b010     |          |          |
| <b>Access Type</b> | –        | Read Only |          |          | –        | Read Only |          |          |

| <b>BITFIELD</b> | <b>BITS</b> | <b>DESCRIPTION</b>                              | <b>DECODE</b>  |
|-----------------|-------------|---|--|
| LF_1            | 6:4         | Line-fault status of wire connected to LMN1 pin | 0b000: Short to battery<br>0b001: Short to GND<br>0b010: Normal operation<br>0b011: Line open<br>0b1XX: Line-to-line short |
| LF_0            | 2:0         | Line-fault status of wire connected to LMN0 pin | 0b000: Short to battery<br>0b001: Short to GND<br>0b010: Normal operation<br>0b011: Line open<br>0b1XX: Line-to-line short |

**REG27 (0x27)**

| <b>BIT</b> | <b>7</b> | <b>6</b> | <b>5</b> | <b>4</b> | <b>3</b> | <b>2</b> | <b>1</b> | <b>0</b> |
|------------|----------|----------|----------|----------|----------|----------|----------|----------|
|------------|----------|----------|----------|----------|----------|----------|----------|----------|

|                    |   |           |   |           |
|--------------------|---|-----------|---|-----------|
| <b>Field</b>       | – | LF_3[2:0] | – | LF_2[2:0] |
| <b>Reset</b>       | – | 0b010     | – | 0b010     |
| <b>Access Type</b> | – | Read Only | – | Read Only |

| BITFIELD | BITS | DESCRIPTION                                     | DECODE   |
|----------|------|---|--|
| LF_3     | 6:4  | Line-fault status of wire connected to LMN3 pin | 0b000: Short to battery<br>0b001: Short to GND<br>0b010: Normal operation<br>0b011: Line open<br>0b1XX: Line-to-line short |
| LF_2     | 2:0  | Line-fault status of wire connected to LMN2 pin | 0b000: Short to battery<br>0b001: Short to GND<br>0b010: Normal operation<br>0b011: Line open<br>0b1XX: Line-to-line short |

**IO\_CHK0 (0x38)**

|                    |                   |          |          |          |          |          |          |          |
|--------------------|-------------------|----------|----------|----------|----------|----------|----------|----------|
| <b>BIT</b>         | <b>7</b>          | <b>6</b> | <b>5</b> | <b>4</b> | <b>3</b> | <b>2</b> | <b>1</b> | <b>0</b> |
| <b>Field</b>       | PIN_DRV_EN_0[7:0] |          |          |          |          |          |          |          |
| <b>Reset</b>       | 0x00              |          |          |          |          |          |          |          |
| <b>Access Type</b> | Write, Read       |          |          |          |          |          |          |          |

| BITFIELD     | BITS | DESCRIPTION   | DECODE  |
|--------------|------|---|---|
| PIN_DRV_EN_0 | 7:0  | <p>Bits 1:0: Set source clock frequency for RGB888 test pattern generator.</p> <p>Used together with register PATGEN_CLK_SRC register bit. When bit 1 of this register is set to 1, PATGEN_CLK_SRC controls the clock selection. When bit 1 is 0, then bit 0 controls the clock selection. See PATGEN_CLK_SRC for more details.</p> <p>Bits 7:2: Reserved</p> | <p>0x00: See RGB888 Video-Pattern Generator Section</p> <p>0x01: See RGB888 Video-Pattern Generator Section</p> <p>0x02: See RGB888 Video-Pattern Generator Section</p> <p>0x03: See RGB888 Video-Pattern Generator Section</p> <p>Others: Reserved</p> |

**PWR0 (0x8)**

|              |                    |          |          |                 |          |          |          |          |
|--------------|--------------------|----------|----------|-----------------|----------|----------|----------|----------|
| <b>BIT</b>   | <b>7</b>           | <b>6</b> | <b>5</b> | <b>4</b>        | <b>3</b> | <b>2</b> | <b>1</b> | <b>0</b> |
| <b>Field</b> | VDDBAD_STATUS[2:0] |          |          | CMP_STATUS[4:0] |          |          |          |          |
| <b>Reset</b> | 0b000              |          |          | 0b00000         |          |          |          |          |

|                    |           |           |
|--------------------|-----------|-----------|
| <b>Access Type</b> | Read Only | Read Only |
|--------------------|-----------|-----------|

| BITFIELD      | BITS | DESCRIPTION   | DECODE   |
|---------------|------|---|--|
| VDDBAD_STATUS | 7:5  | Switched 1V supply comparator status bits   | 0bXX1: Latched high when CAP_VDD < 0.82V<br>0bX1X: Latched high when CAP_VDD < 0.82V<br>0bX00: CAP_VDD > 0.82V<br>0b1XX: Reserved  |
| CMP_STATUS    | 4:0  | V <sub>DD18</sub> , V <sub>DDIO</sub> , and CAP_VDD supply voltage comparator status bits | 0bXXXX0: Latched low when V <sub>DD18</sub> < 1.617V<br>0bXXX0X: Latched low when switched V <sub>DDIO</sub> supply < 1.617V<br>0bXX0XX: Latched low when CAP_VDD < 0.82V<br>0bX0XXX: Reserved<br>0b0XXX: Reserved<br>0bXX111: All supplies are at expected levels |

**PWR1 (0x9)**

| BIT                | 7 | 6 | 5                | 4 | 3 | 2 | 1 | 0 |
|--------------------|---|---|------------------|---|---|---|---|---|
| <b>Field</b>       | – | – | PORZ_STATUS[5:0] |   |   |   |   |   |
| <b>Reset</b>       | – | – | 0b000000         |   |   |   |   |   |
| <b>Access Type</b> | – | – | Read Only        |   |   |   |   |   |

| BITFIELD    | BITS | DESCRIPTION   | DECODE   |
|-------------|------|---|--|
| PORZ_STATUS | 5:0  | Power-on-reset status bits<br>Bit 0: Latched low when either V <sub>DD18</sub> < 1.516V or V <sub>DDIO</sub> < 1.055V | Bit 1: Reserved<br>Bit 2: Latched low when V <sub>DDIO</sub> < 1.055V<br>Bit 3: Reserved<br>Bit 4: Latched low when V <sub>DD18</sub> < 1.516V (resets 1V domain, need to raise V <sub>DD18</sub> above 1.516V to read registers)<br>Bit 5: Reserved |

**PWR4 (0xC)**

| BIT                | 7 | 6              | 5           | 4           | 3 | 2 | 1 | 0 |
|--------------------|---|----------------|-------------|-------------|---|---|---|---|
| <b>Field</b>       | – | DIS_LOCAL_WAKE | WAKE_EN_B   | WAKE_EN_A   | – | – | – | – |
| <b>Reset</b>       | – | 0b0            | 0b0         | 0b1         | – | – | – | – |
| <b>Access Type</b> | – | Write, Read    | Write, Read | Write, Read | – | – | – | – |

| BITFIELD       | BITS | DESCRIPTION                                 | DECODE  |
|----------------|------|---|---|
| DIS_LOCAL_WAKE | 6    | Disable wake-up by local μC from SDA_RX pin | 0b0: Local wake-up enabled<br>0b1: Local wake-up disabled |

| BITFIELD  | BITS | DESCRIPTION                                       | DECODE  |
|-----------|------|---|---|
| WAKE_EN_B | 5    | Enable wake-up by remote chip connected to Link B | 0b0: Link B remote wake-up disabled<br>0b1: Link B remote wake-up enabled |
| WAKE_EN_A | 4    | Enable wake-up by remote chip connected to Link A | 0b0: Link A remote wake-up disabled<br>0b1: Link A remote wake-up enabled |

**CTRL0 (0x10)**

| BIT         | 7           | 6           | 5                         | 4           | 3           | 2           | 1             | 0 |
|-------------|-------------|-------------|---------------------------|-------------|-------------|-------------|---------------|---|
| Field       | RESET_ALL   | RESET_LINK  | RESET_ONESHOT             | AUTO_LINK   | SLEEP       | REG_ENABLE  | LINK_CFG[1:0] |   |
| Reset       | 0b0         | 0b0         | 0b0                       | 0b1         | 0b0         | 0b0         | 0b01          |   |
| Access Type | Write, Read | Write, Read | Write Clears All,<br>Read | Write, Read | Write, Read | Write, Read | Write, Read   |   |

| BITFIELD      | BITS | DESCRIPTION   | DECODE  |
|---------------|------|---|---|
| RESET_ALL     | 7    | Device Reset<br>Writing a 1 to this bit resets the device (including all blocks) and resets registers to defaults. This is equivalent to toggling the PWDNB pin. The bit is cleared when written. | 0b0: No action<br>0b1: Activate chip reset  |
| RESET_LINK    | 6    | Link Reset<br>Resets entire data path on Link A (keep register settings). Write 1 to activate reset, write 0 to release reset.  | 0b0: Release link A reset<br>0b1: Activate link A reset   |
| RESET_ONESHOT | 5    | One-Shot Link Reset<br>Reset entire data path on Link A (keep register settings). Write 1 to activate reset, bit self clears and automatically releases reset.                                    | 0b0: No action<br>0b1: Reset data path  |
| AUTO_LINK     | 4    | Automatically selects link configuration (single A or single B)<br>Reverse splitter mode (two GMSL links enabled) is not automatic. For reverse splitter mode, set LINK_CFG = 11.                 | 0b0: Disable auto link configuration<br>0b1: Enable auto link configuration   |
| SLEEP         | 3    | Activates sleep mode  | 0b0: Sleep mode disabled<br>0b1: Sleep mode enabled   |
| REG_ENABLE    | 2    | Enables V <sub>DD</sub> LDO regulator. See Programming Notes.   | 0b0: V <sub>DD</sub> LDO regulator bypassed<br>0b1: V <sub>DD</sub> LDO regulator enabled. LDO should always be used unless V <sub>DD</sub> is 1.05V or lower.  |
| LINK_CFG      | 1:0  | AUTO_LINK and this bitfield selects the link configuration per the decode table.  | 0b00: Reserved<br>0b01: Reserved. To select link A only, use LINK_EN_A and LINK_EN_B registers. This is the method to manually select link A only.<br>0b10: Reserved. To select link A only, use LINK_EN_A and LINK_EN_B registers. This is the method to manually select link B only.<br>0b11: Reverse Splitter mode. Both Link A and Link B selected. |

**CTRL1 (0x11)**

| BIT         | 7 | 6 | 5 | 4 | 3 | 2           | 1 | 0           |
|-------------|---|---|---|---|---|-------------|---|-------------|
| Field       | – | – | – | – | – | CXTP_B      | – | CXTP_A      |
| Reset       | – | – | – | – | – | 0b0         | – | 0b0         |
| Access Type | – | – | – | – | – | Write, Read | – | Write, Read |

| BITFIELD | BITS | DESCRIPTION   | DECODE  |
|----------|------|---|---|
| CXTP_B   | 2    | Coax/twisted-pair cable select for Link B<br>Bit is set according to the latched CFG pin value at power-up. | 0b0: Shielded twisted-pair drive<br>0b1: Coax drive |
| CXTP_A   | 0    | Coax/twisted-pair cable select for Link A<br>Bit is set according to the latched CFG pin value at power-up. | 0b0: Shielded twisted-pair drive<br>0b1: Coax drive |

**CTRL2 (0x12)**

| BIT         | 7 | 6 | 5                      | 4           | 3 | 2 | 1 | 0 |
|-------------|---|---|------------------------|-------------|---|---|---|---|
| Field       | – | – | RESET_ONESHOT_B        | REG_MNL     | – | – | – | – |
| Reset       | – | – | 0b0                    | 0b0         | – | – | – | – |
| Access Type | – | – | Write Clears All, Read | Write, Read | – | – | – | – |

| BITFIELD        | BITS | DESCRIPTION  | DECODE   |
|-----------------|------|--|--|
| RESET_ONESHOT_B | 5    | Reset entire data path on Link B (keep register settings).<br>Write 1 to activate reset, bit self clears and automatically releases reset. | 0b0: No action<br>0b1: Reset data path         |
| REG_MNL         | 4    | Enable regulator manual mode to allow regulator to be forced on or off through REG_ENABLE (0x10).  | 0b0: Normal mode<br>0b1: Regulator manual mode |

**CTRL3 (0x13)**

| BIT         | 7 | 6 | 5              | 4 | 3         | 2         | 1          | 0            |
|-------------|---|---|----------------|---|-----------|-----------|------------|--------------|
| Field       | – | – | LINK_MODE[1:0] |   | LOCKED    | ERROR     | CMU_LOCKED | RESET_LINK_B |
| Reset       | – | – | 0b01           |   | 0b0       | 0b0       | 0b0        | 0b0          |
| Access Type | – | – | Read Only      |   | Read Only | Read Only | Read Only  | Write, Read  |

| BITFIELD     | BITS | DESCRIPTION  | DECODE  |
|--------------|------|--|---|
| LINK_MODE    | 5:4  | Active link mode status  | 0b00: Reserved<br>0b01: Single Link A<br>0b10: Single Link B<br>0b11: Reverse Splitter mode (Both link A and B) |
| LOCKED       | 3    | GMSL link locked (bidirectional). For Link A only.   | 0b0: GMSL2 link A not locked<br>0b1: GMSL2 link A locked  |
| ERROR        | 2    | Reflects global error status   | 0b0: ERRB not asserted (ERRB pin = 1)<br>0b1: ERRB asserted (ERRB pin = 0)                                      |
| CMU_LOCKED   | 1    | Clock multiplier unit (CMU) locked   | 0b0: CMU not locked<br>0b1: CMU locked  |
| RESET_LINK_B | 0    | Reset entire data path on Link B (keep register settings).<br><br>Write 1 to activate reset, write 0 to release reset. | 0b0: Release link B reset<br>0b1: Activate link B reset   |

**INTR0 (0x18)**

| BIT         | 7 | 6 | 5 | 4 | 3               | 2                | 1 | 0 |
|-------------|---|---|---|---|-----------------|------------------|---|---|
| Field       | – | – | – | – | AUTO_ERR_RST_EN | DEC_ERR_THR[2:0] |   |   |
| Reset       | – | – | – | – | 0b0             | 0b000            |   |   |
| Access Type | – | – | – | – | Write, Read     | Write, Read      |   |   |

| BITFIELD        | BITS | DESCRIPTION   | DECODE   |
|-----------------|------|---|--|
| AUTO_ERR_RST_EN | 3    | Automatically resets DEC_ERR_A (0x22), DEC_ERR_B (0x23), and IDLE_ERR (0x24) bitfields after ERRB pin is asserted for 1 $\mu$ s.  | 0b0: Autoreset disabled<br>0b1: Autoreset enabled  |
| DEC_ERR_THR     | 2:0  | Decoding and Idle-Error Reporting Threshold<br><br>DEC_ERR_FLAG_A (0x1B) is asserted when DEC_ERR_A (0x22) $\geq$ DEC_ERR_THR.<br><br>DEC_ERR_FLAG_B (0x1B) is asserted when DEC_ERR_B (0x23) $\geq$ DEC_ERR_THR.<br><br>IDLE_ERR_FLAG (0x1B) is asserted when IDLE_ERR (0x24) $\geq$ DEC_ERR_THR.<br><br>IDLE_ERR_FLAG_B (0x5011) is asserted when IDLE_ERR_B (0x5024) $\geq$ DEC_ERR_THR. | 0b000: 1 error<br>0b001: 2 errors<br>0b010: 4 errors<br>0b011: 8 errors<br>0b100: 16 errors<br>0b101: 32 errors<br>0b110: 64 errors<br>0b111: 128 errors |

**INTR1 (0x19)**

| BIT   | 7                | 6 | 5 | 4 | 3               | 2                | 1 | 0 |
|-------|------------------|---|---|---|-----------------|------------------|---|---|
| Field | PKT_CNT_EXP[3:0] |   |   |   | AUTO_CNT_RST_EN | PKT_CNT_THR[2:0] |   |   |
| Reset | 0x0              |   |   |   | 0b0             | 0b000            |   |   |

|                    |             |             |             |
|--------------------|-------------|-------------|-------------|
| <b>Access Type</b> | Write, Read | Write, Read | Write, Read |
|--------------------|-------------|-------------|-------------|

| BITFIELD        | BITS | DESCRIPTION  | DECODE   |
|-----------------|------|--|--|
| PKT_CNT_EXP     | 7:4  | Packet-Count Multiplier Exponent<br><br>See the description of PKT_CNT (register CNT3) bitfield.   | 0bXXX: PKT_CNT exponent  |
| AUTO_CNT_RST_EN | 3    | Automatically resets PKT_CNT bitfield (register CNT3) after ERRB pin is asserted for 1 $\mu$ s.  | 0b0: Autoreset disabled<br>0b1: Autoreset enabled  |
| PKT_CNT_THR     | 2:0  | Packet-count reporting threshold<br><br>See the description of PKT_CNT (register CNT3).<br><br>PKT_CNT_FLAG is asserted when PKT_CNT $\geq$ PKT_CNT_THR. | 0b000: 1 packet<br>0b001: 2 packets<br>0b010: 4 packets<br>0b011: 8 packets<br>0b100: 16 packets<br>0b101: 32 packets<br>0b110: 64 packets<br>0b111: 128 packets |

**INTR2 (0x1A)**

| BIT                | 7 | 6 | 5           | 4 | 3            | 2            | 1             | 0             |
|--------------------|---|---|-------------|---|--------------|--------------|---------------|---------------|
| <b>Field</b>       | – | – | REM_ERR_OEN | – | LFLT_INT_OEN | IDLE_ERR_OEN | DEC_ERR_OEN_B | DEC_ERR_OEN_A |
| <b>Reset</b>       | – | – | 0b0         | – | 0b1          | 0b0          | 0b1           | 0b1           |
| <b>Access Type</b> | – | – | Write, Read | – | Write, Read  | Write, Read  | Write, Read   | Write, Read   |

| BITFIELD      | BITS | DESCRIPTION  | DECODE  |
|---------------|------|--|---|
| REM_ERR_OEN   | 5    | Enables reporting of remote-error status (REM_ERR_FLAG - 0x1B) at ERRB pin | 0b0: Reporting disabled<br>0b1: Reporting enabled |
| LFLT_INT_OEN  | 3    | Enables reporting of line-fault interrupt (LFLT_INT - 0x1B ) at ERRB pin   | 0b0: Reporting disabled<br>0b1: Reporting enabled |
| IDLE_ERR_OEN  | 2    | Enables reporting of idle-word errors (IDLE_ERR_FLAG - 0x1B) at ERRB pin   | 0b0: Reporting disabled<br>0b1: Reporting enabled |
| DEC_ERR_OEN_B | 1    | Enables reporting of decoding errors (DEC_ERR_FLAG_B - 0x1B) at ERRB pin   | 0b0: Reporting disabled<br>0b1: Reporting enabled |
| DEC_ERR_OEN_A | 0    | Enable reporting of decoding errors (DEC_ERR_FLAG_A - 0x1B) at ERRB pin    | 0b0: Reporting disabled<br>0b1: Reporting enabled |

**INTR3 (0x1B)**

| BIT          | 7 | 6 | 5            | 4 | 3        | 2             | 1              | 0              |
|--------------|---|---|--------------|---|----------|---------------|----------------|----------------|
| <b>Field</b> | – | – | REM_ERR_FLAG | – | LFLT_INT | IDLE_ERR_FLAG | DEC_ERR_FLAG_B | DEC_ERR_FLAG_A |
| <b>Reset</b> | – | – | 0b0          | – | 0b0      | 0b0           | 0b0            | 0b0            |

|             |   |   |           |   |           |           |           |           |
|-------------|---|---|-----------|---|-----------|-----------|-----------|-----------|
| Access Type | – | – | Read Only | – | Read Only | Read Only | Read Only | Read Only |
|-------------|---|---|-----------|---|-----------|-----------|-----------|-----------|

| BITFIELD       | BITS | DESCRIPTION  | DECODE  |
|----------------|------|--|---|
| REM_ERR_FLAG   | 5    | Received remote-side error status (inverse of remote side ERRB pin level)  | 0b0: No remote-side error<br>0b1: Remote-side error |
| LFLT_INT       | 3    | Line-Fault Interrupt<br>Asserted when any one of line-fault monitors indicates a fault status. See LF_0 (0x26) and LF_1 (0x26) bitfields for more information. | 0b0: No line fault<br>0b1: Line fault               |
| IDLE_ERR_FLAG  | 2    | Idle-Word-Error Flag for Link A<br>Asserted when IDLE_ERR (0x23) ≥ DEC_ERR_THR (0x18). For Link A only.  | 0b0: Flag not asserted<br>0b1: Flag asserted        |
| DEC_ERR_FLAG_B | 1    | Decoding Error Flag for Link B<br>Asserted when DEC_ERR_B (0x23) ≥ DEC_ERR_THR (0x18).   | 0b0: Flag not asserted<br>0b1: Flag asserted        |
| DEC_ERR_FLAG_A | 0    | Decoding Error Flag for Link A<br>Asserted when DEC_ERR_A (0x22) ≥ DEC_ERR_THR (0x18).   | 0b0: Flag not asserted<br>0b1: Flag asserted        |

**INTR4 (0x1C)**

| BIT         | 7             | 6             | 5              | 4 | 3           | 2           | 1           | 0           |
|-------------|---------------|---------------|----------------|---|-------------|-------------|-------------|-------------|
| Field       | EOM_ERR_OEN_B | EOM_ERR_OEN_A | FEC_RX_ERR_OEN | – | MAX_RT_OEN  | RT_CNT_OEN  | PKT_CNT_OEN | WM_ERR_OEN  |
| Reset       | 0b0           | 0b0           | 0b0            | – | 0b1         | 0b0         | 0b0         | 0b1         |
| Access Type | Write, Read   | Write, Read   | Write, Read    | – | Write, Read | Write, Read | Write, Read | Write, Read |

| BITFIELD       | BITS | DESCRIPTION   | DECODE  |
|----------------|------|---|---|
| EOM_ERR_OEN_B  | 7    | Enable reporting of eye-opening monitor (EOM) error (EOM_ERR_FLAG_B - 0x1D) for Link B at ERRB pin.               | 0b0: Reporting disabled<br>0b1: Reporting enabled |
| EOM_ERR_OEN_A  | 6    | Enable reporting of eye-opening monitor error (EOM_ERR_FLAG_A - 0x1D) for Link A at ERRB pin.                     | 0b0: Reporting disabled<br>0b1: Reporting enabled |
| FEC_RX_ERR_OEN | 5    | Enable reporting of Link A FEC receive errors exceeding thresholds (FEC_ERR_FLAG - 0x1D) at ERRB pin.             | 0b0: Reporting disabled<br>0b1: Reporting enabled |
| MAX_RT_OEN     | 3    | Enable reporting of Link A combined ARQ maximum retransmission limit error flag (MAX_RT_FLAG - 0x1D) at ERRB pin. | 0b0: Reporting disabled<br>0b1: Reporting enabled |

| BITFIELD    | BITS | DESCRIPTION   | DECODE  |
|-------------|------|---|---|
| RT_CNT_OEN  | 2    | Enable reporting of Link A combined ARQ retransmission event flag (RT_CNT_FLAG - 0x1D) at ERRB pin. | 0b0: Reporting disabled<br>0b1: Reporting enabled |
| PKT_CNT_OEN | 1    | Enable reporting of Link A packet count flag (PKT_CNT_FLAG - 0x1D) at ERRB pin.                     | 0b0: Reporting disabled<br>0b1: Reporting enabled |
| WM_ERR_OEN  | 0    | Enable reporting of watermark errors (WM_ERR_FLAG - 0x1D) at ERRB pin                               | 0b0: Reporting disabled<br>0b1: Reporting enabled |

**INTR5 (0x1D)**

| BIT         | 7              | 6              | 5               | 4 | 3           | 2           | 1            | 0               |
|-------------|----------------|----------------|-----------------|---|-------------|-------------|--------------|-----------------|
| Field       | EOM_ERR_FLAG_B | EOM_ERR_FLAG_A | FEC_RX_ERR_FLAG | – | MAX_RT_FLAG | RT_CNT_FLAG | PKT_CNT_FLAG | WM_ERR_FLAG     |
| Reset       | 0b0            | 0b0            | 0b0             | – | 0b0         | 0b0         | 0b0          | 0b0             |
| Access Type | Read Only      | Read Only      | Read Only       | – | Read Only   | Read Only   | Read Only    | Read Clears All |

| BITFIELD        | BITS | DESCRIPTION  | DECODE  |
|-----------------|------|--|---|
| EOM_ERR_FLAG_B  | 7    | Eye-opening is below configured threshold for Link B   | 0b0: No EOM error on Link B<br>0b1: EOM error on Link B |
| EOM_ERR_FLAG_A  | 6    | Eye-opening is below configured threshold for Link A   | 0b0: No EOM error on Link A<br>0b1: EOM error on Link A |
| FEC_RX_ERR_FLAG | 5    | FEC Receive Errors Flag for Link A<br><br>Asserted when the FEC receiver correctable OR uncorrectable error counters exceed their thresholds for the first time. When reading this flag, the status gets cleared. The FEC statistics counters must also be reset for this flag to be asserted again. See the CLEAR_STATS register to reset the counters. | 0b0: Flag not asserted<br>0b1: Flag asserted            |
| MAX_RT_FLAG     | 3    | Combined ARQ maximum retransmission limit error flag. For Link A only.<br><br>Asserted when any of the selected channel's ARQ retransmission limit is reached.<br><br>Selection is done by each channel's MAX_RT_ERR_OEN (0x1C) register bit.  | 0b0: Flag not asserted<br>0b1: Flag asserted            |
| RT_CNT_FLAG     | 2    | Combined ARQ Retransmission Event Flag. For Link A only.<br><br>Asserted when any of the selected channels have done at least one ARQ retransmission.<br><br>Selection is done by each channel's RT_CNT_OEN register bit.  | 0b0: Flag not asserted<br>0b1: Flag asserted            |
| PKT_CNT_FLAG    | 1    | Packet Count Flag. For Link A only.  | 0b0: Flag not asserted<br>0b1: Flag asserted            |

| BITFIELD    | BITS | DESCRIPTION   | DECODE                                       |
|-------------|------|---|--|
|             |      | Asserted when PKT_CNT (0x25) ≥ PKT_CNT_THR (0x19)                   |  |
| WM_ERR_FLAG | 0    | Watermark Error Flag<br>Asserted when a watermark error is detected | 0b0: Flag not asserted<br>0b1: Flag asserted |

**INTR6 (0x1E)**

| BIT         | 7              | 6 | 5              | 4             | 3            | 2             | 1 | 0                   |
|-------------|----------------|---|----------------|---------------|--------------|---------------|---|---------------------|
| Field       | VDDCMP_INT_OEN | – | VDDBAD_INT_OEN | FSYNC_ERR_OEN | LCRC_ERR_OEN | VPRBS_ERR_OEN | – | VID_PXL_CRC_ERR_OEN |
| Reset       | 0b0            | – | 0b0            | 0b1           | 0b1          | 0b1           | – | 0b0                 |
| Access Type | Write, Read    | – | Write, Read    | Write, Read   | Write, Read  | Write, Read   | – | Write, Read         |

| BITFIELD            | BITS | DESCRIPTION  | DECODE  |
|---------------------|------|--|---|
| VDDCMP_INT_OEN      | 7    | Enable reporting of V <sub>D</sub> DCMP interrupt (VDDCMP_INT_FLAG - 0x1F) at ERRB pin | 0b0: Reporting disabled<br>0b1: Reporting enabled |
| VDDBAD_INT_OEN      | 5    | Enable reporting of V <sub>D</sub> DBAD interrupt (VDDBAD_INT_FLAG - 0x1F) at ERRB pin | 0b0: Reporting disabled<br>0b1: Reporting enabled |
| FSYNC_ERR_OEN       | 4    | Enable reporting of frame-sync errors (FSYNC_ERR_FLAG - 0x1F) at ERRB pin              | 0b0: Reporting disabled<br>0b1: Reporting enabled |
| LCRC_ERR_OEN        | 3    | Enable reporting of video-line CRC errors (LCRC_ERR_FLAG - 0x1F) at ERRB pin           | 0b0: Reporting disabled<br>0b1: Reporting enabled |
| VPRBS_ERR_OEN       | 2    | Enable reporting of video PRBS errors (VPRBS_ERR_FLAG - 0x1F) at ERRB pin              | 0b0: Reporting disabled<br>0b1: Reporting enabled |
| VID_PXL_CRC_ERR_OEN | 0    | Enable reporting of GMSL link packet CRC errors for video pixel data at ERRB pin       | 0b0: Reporting disabled<br>0b1: Reporting enabled |

**INTR7 (0x1F)**

| BIT         | 7               | 6 | 5               | 4              | 3             | 2              | 1 | 0                    |
|-------------|-----------------|---|-----------------|----------------|---------------|----------------|---|----------------------|
| Field       | VDDCMP_INT_FLAG | – | VDDBAD_INT_FLAG | FSYNC_ERR_FLAG | LCRC_ERR_FLAG | VPRBS_ERR_FLAG | – | VID_PXL_CRC_ERR_FLAG |
| Reset       | 0b0             | – | 0b0             | 0b0            | 0b0           | 0b0            | – | 0b0                  |
| Access Type | Read Only       | – | Read Only       | Read Only      | Read Only     | Read Only      | – | Read Only            |

| BITFIELD        | BITS | DESCRIPTION   | DECODE   |
|-----------------|------|---|--|
| VDDCMP_INT_FLAG | 7    | VDDCMP interrupt flag. This is a combined flag for undervoltage conditions for V <sub>DD18</sub> , V <sub>DDIO</sub> , CAP_VDD, and V <sub>TERM</sub> . | 0b0: Flag not asserted<br>0b1: Flag asserted   |
| VDDBAD_INT_FLAG | 5    | V <sub>DD</sub> status interrupt. This is a flag for CAP_VDD undervoltage condition.  | 0b0: Flag not asserted<br>0b1: Flag asserted   |
| FSYNC_ERR_FLAG  | 4    | Frame-sync error flag<br>Asserted when FSYNC_ERR_CNT (0x3F0) ≥ FSYNC_ERR_THR (0x3F1).   | 0b0: Flag not asserted<br>0b1: Flag asserted   |
| LCRC_ERR_FLAG   | 3    | Video-line CRC error flag<br>Asserted when a video-line CRC error is detected.  | 0b0: Flag not asserted<br>0b1: Flag asserted   |
| VPRBS_ERR_FLAG  | 2    | Video PRBS error flag<br>Asserted when VPRBS_ERR (register PRBS_ERR) > 0  | 0b0: Flag not asserted<br>0b1: Flag asserted   |
| VID_PXL_CRC_ERR | 0    | GMSL link packet CRC error flag for video pixel data  | 0b0: Error counter interrupt output not enabled<br>0b1: Error counter interrupt output enabled |

**INTR8 (0x20)**

| BIT         | 7           | 6 | 5           | 4              | 3 | 2 | 1 | 0 |
|-------------|-------------|---|-------------|----------------|---|---|---|---|
| Field       | ERR_TX_EN   | – | ERR_TX_EN_B | ERR_TX_ID[4:0] |   |   |   |   |
| Reset       | 0b1         | – | 0b1         | 0b11111        |   |   |   |   |
| Access Type | Write, Read | – | Write, Read | Write, Read    |   |   |   |   |

| BITFIELD    | BITS | DESCRIPTION  | DECODE  |
|-------------|------|--|---|
| ERR_TX_EN   | 7    | Transmit local error status (inverse of ERRB pin level) to Link A remote side through GPIO channel | 0b0: Transmit error status disabled<br>0b1: Transmit error status enabled |
| ERR_TX_EN_B | 5    | Transmit local-error status (inverse of ERRB pin level) to Link B remote side through GPIO channel | 0b0: Transmit error status disabled<br>0b1: Transmit error status enabled |
| ERR_TX_ID   | 4:0  | GPIO ID used for transmitting ERR_TX   | 0bXXXXX: Value of GPIO ID for transmitting ERR_TX                         |

**INTR9 (0x21)**

| BIT         | 7           | 6 | 5           | 4              | 3 | 2 | 1 | 0 |
|-------------|-------------|---|-------------|----------------|---|---|---|---|
| Field       | ERR_RX_EN   | – | ERR_RX_EN_B | ERR_RX_ID[4:0] |   |   |   |   |
| Reset       | 0b1         | – | 0b1         | 0b11111        |   |   |   |   |
| Access Type | Write, Read | – | Write, Read | Write, Read    |   |   |   |   |

| BITFIELD    | BITS | DESCRIPTION   | DECODE  |
|-------------|------|---|---|
| ERR_RX_EN   | 7    | Receive Link A remote-error status (inverse of ERRB pin level) through GPIO channel | 0b0: Receive error status disabled<br>0b1: Receive error status enabled |
| ERR_RX_EN_B | 5    | Receive Link B remote-error status (inverse of ERRB pin level) through GPIO channel | 0b0: Receive error status disabled<br>0b1: Receive error status enabled |
| ERR_RX_ID   | 4:0  | GPIO ID used for receiving ERR_RX   | 0bXXXXX: Value of GPIO ID for receiving ERR_RX                          |

**CNT0 (0x22)**

| BIT         | 7               | 6 | 5 | 4 | 3 | 2 | 1 | 0 |
|-------------|-----------------|---|---|---|---|---|---|---|
| Field       | DEC_ERR_A[7:0]  |   |   |   |   |   |   |   |
| Reset       | 0x00            |   |   |   |   |   |   |   |
| Access Type | Read Clears All |   |   |   |   |   |   |   |

| BITFIELD  | BITS | DESCRIPTION  | DECODE  |
|-----------|------|--|---|
| DEC_ERR_A | 7:0  | Number of decoding (disparity) errors detected at Link A<br><br>Reset after reading or with the rising edge of LOCK. | 0xXX: Number of Link A decoding errors detected |

**CNT1 (0x23)**

| BIT         | 7               | 6 | 5 | 4 | 3 | 2 | 1 | 0 |
|-------------|-----------------|---|---|---|---|---|---|---|
| Field       | DEC_ERR_B[7:0]  |   |   |   |   |   |   |   |
| Reset       | 0x00            |   |   |   |   |   |   |   |
| Access Type | Read Clears All |   |   |   |   |   |   |   |

| BITFIELD  | BITS | DESCRIPTION  | DECODE  |
|-----------|------|--|---|
| DEC_ERR_B | 7:0  | Number of decoding (disparity) errors detected at Link B<br><br>Reset after reading or with the rising edge of LOCK. | 0xXX: Number of Link B decoding errors detected |

**CNT2 (0x24)**

| BIT   | 7             | 6 | 5 | 4 | 3 | 2 | 1 | 0 |
|-------|---------------|---|---|---|---|---|---|---|
| Field | IDLE_ERR[7:0] |   |   |   |   |   |   |   |
| Reset | 0x00          |   |   |   |   |   |   |   |

|                    |                 |
|--------------------|-----------------|
| <b>Access Type</b> | Read Clears All |
|--------------------|-----------------|

| <b>BITFIELD</b> | <b>BITS</b> | <b>DESCRIPTION</b>  | <b>DECODE</b>                             |
|-----------------|-------------|---|---|
| IDLE_ERR        | 7:0         | Number of idle-word errors detected for Link A.<br>Reset after reading or with the rising edge of LOCK. | 0xXX: Number of idle-word errors detected |

**CNT3 (0x25)**

| <b>BIT</b>         | <b>7</b>        | <b>6</b> | <b>5</b> | <b>4</b> | <b>3</b> | <b>2</b> | <b>1</b> | <b>0</b> |
|--------------------|-----------------|----------|----------|----------|----------|----------|----------|----------|
| <b>Field</b>       | PKT_CNT[7:0]    |          |          |          |          |          |          |          |
| <b>Reset</b>       | 0x00            |          |          |          |          |          |          |          |
| <b>Access Type</b> | Read Clears All |          |          |          |          |          |          |          |

| <b>BITFIELD</b> | <b>BITS</b> | <b>DESCRIPTION</b>   | <b>DECODE</b>                           |
|-----------------|-------------|--|---|
| PKT_CNT         | 7:0         | Number of received packets of a selected type for Link A<br><br>Packet type is selected with PKT_CNT_SEL (0x2C) register.<br><br>Reported packet count is a scaled value, such that actual packet count is $\geq \text{PKT\_CNT} \times (2^{\text{PKT\_CNT\_EXP}})$ and $< (\text{PKT\_CNT} + 1) \times (2^{\text{PKT\_CNT\_EXP}})$ .<br><br>When maximum value is reported, packet count is greater or equal to the reported value. | 0xXX: Scaled number of received packets |

**TX0 (0x28)**

| <b>BIT</b>         | <b>7</b> | <b>6</b> | <b>5</b> | <b>4</b> | <b>3</b> | <b>2</b> | <b>1</b>    | <b>0</b> |
|--------------------|----------|----------|----------|----------|----------|----------|-------------|----------|
| <b>Field</b>       | –        | –        | –        | –        | –        | –        | RX_FEC_EN   | –        |
| <b>Reset</b>       | –        | –        | –        | –        | –        | –        | 0b0         | –        |
| <b>Access Type</b> | –        | –        | –        | –        | –        | –        | Write, Read | –        |

| <b>BITFIELD</b> | <b>BITS</b> | <b>DESCRIPTION</b>   | <b>DECODE</b>               |
|-----------------|-------------|--|-----------------------------|
| RX_FEC_EN       | 1           | Enable FEC on Link A in forward direction.<br>For GMSL3 parts, bit is set according to the latched CFG1 pin value at power-up. | 0b0: Disable<br>0b1: Enable |

**TX1 (0x29)**

| BIT         | 7             | 6 | 5 | 4           | 3 | 2 | 1 | 0 |
|-------------|---------------|---|---|-------------|---|---|---|---|
| Field       | LINK_PRBS_GEN | – | – | ERRG_EN_A   | – | – | – | – |
| Reset       | 0b0           | – | – | 0b0         | – | – | – | – |
| Access Type | Write, Read   | – | – | Write, Read | – | – | – | – |

| BITFIELD      | BITS | DESCRIPTION   | DECODE  |
|---------------|------|---|---|
| LINK_PRBS_GEN | 7    | Enable link PRBS-7 generator  | 0x0: Disabled<br>0x1: Enabled   |
| ERRG_EN_A     | 4    | Error generator enable for Link A (reverse channel). Error injection applies to all data going across the link. | 0b0: Link A error generator disabled<br>0b1: Link A error generator enabled |

**TX2 (0x2A)**

| BIT         | 7             | 6 | 5              | 4 | 3               | 2 | 1 | 0           |
|-------------|---------------|---|----------------|---|-----------------|---|---|-------------|
| Field       | ERRG_CNT[1:0] |   | ERRG_RATE[1:0] |   | ERRG_BURST[2:0] |   |   | ERRG_PER    |
| Reset       | 0b00          |   | 0b10           |   | 0b000           |   |   | 0b0         |
| Access Type | Write, Read   |   | Write, Read    |   | Write, Read     |   |   | Write, Read |

| BITFIELD   | BITS | DESCRIPTION                                  | DECODE   |
|------------|------|--|--|
| ERRG_CNT   | 7:6  | Number of errors to be generated             | 0b00: Continuous<br>0b01: 16 errors<br>0b10: 128 errors<br>0b11: 1024 errors                         |
| ERRG_RATE  | 5:4  | Error generator average bit-error rate       | 0b00: 1 in 5120 bits<br>0b01: 1 in 81920 bits<br>0b10: 1 in 1310720 bits<br>0b11: 1 in 20971520 bits |
| ERRG_BURST | 3:1  | Error generator burst-error length           | 0b000: 1<br>0b001: 2<br>0b010: 3<br>0b011: 4<br>0b100: 8<br>0b101: 12<br>0b110: 16<br>0b111: 20      |
| ERRG_PER   | 0    | Error generator error-distribution selection | 0b0: Pseudorandom<br>0b1: Periodic   |

**TX3 (0x2B)**

| BIT   | 7 | 6 | 5             | 4 | 3 | 2 | 1 | 0 |
|-------|---|---|---------------|---|---|---|---|---|
| Field | – | – | RX_FEC_ACTIVE | – | – | – | – | – |

|                    |   |   |           |   |   |   |   |   |
|--------------------|---|---|-----------|---|---|---|---|---|
| <b>Reset</b>       | - | - | 0b0       | - | - | - | - | - |
| <b>Access Type</b> | - | - | Read Only | - | - | - | - | - |

| <b>BITFIELD</b> | <b>BITS</b> | <b>DESCRIPTION</b> | <b>DECODE</b>                         |
|-----------------|-------------|--------------------|---------------------------------------|
| RX_FEC_ACTIVE   | 5           | FEC is active      | 0b0: FEC disabled<br>0b1: FEC enabled |

**RX0 (0x2C)**

| <b>BIT</b>         | <b>7</b>         | <b>6</b> | <b>5</b> | <b>4</b> | <b>3</b>         | <b>2</b> | <b>1</b> | <b>0</b> |
|--------------------|------------------|----------|----------|----------|------------------|----------|----------|----------|
| <b>Field</b>       | PKT_CNT_LBW[1:0] |          | -        | -        | PKT_CNT_SEL[3:0] |          |          |          |
| <b>Reset</b>       | 0b00             |          | -        | -        | 0x0              |          |          |          |
| <b>Access Type</b> | Write, Read      |          | -        | -        | Write, Read      |          |          |          |

| <b>BITFIELD</b> | <b>BITS</b> | <b>DESCRIPTION</b>   | <b>DECODE</b>   |
|-----------------|-------------|--|---|
| PKT_CNT_LBW     | 7:6         | Select the subtype of low-bandwidth (LBW) packets to count at PKT_CNT (0x25) bitfield register.  | 0b00: Count LBW data packets only<br>0b01: Count LBW acknowledge packets only<br>0b10: Count LBW data and acknowledge packets<br>0b11: Reserved   |
| PKT_CNT_SEL     | 3:0         | Select the type of received packets to count at PKT_CNT (0x25) bitfield<br><br>The selected packet type must be supported by the device. | 0x0: None<br>0x1: VIDEO<br>0x2: Reserved<br>0x3: INFO Frame<br>0x4: SPI<br>0x5: I <sup>2</sup> C<br>0x6: UART<br>0x7: GPIO<br>0x8: Reserved<br>0x9: Reserved<br>0xA: Reserved<br>0xB: Reserved<br>0xC: Reserved<br>0xD: Reserved<br>0xE: All<br>0xF: Unknown and packets with error |

**RX1 (0x2D)**

| <b>BIT</b>         | <b>7</b>      | <b>6</b> | <b>5</b> | <b>4</b> | <b>3</b> | <b>2</b> | <b>1</b> | <b>0</b> |
|--------------------|---------------|----------|----------|----------|----------|----------|----------|----------|
| <b>Field</b>       | LINK_PRBS_CHK | -        | -        | -        | -        | -        | -        | -        |
| <b>Reset</b>       | 0b0           | -        | -        | -        | -        | -        | -        | -        |
| <b>Access Type</b> | Write, Read   | -        | -        | -        | -        | -        | -        | -        |

| BITFIELD      | BITS | DESCRIPTION                | DECODE                        |
|---------------|------|----------------------------|-------------------------------|
| LINK_PRBS_CHK | 7    | Enable link PRBS-7 checker | 0x0: Disabled<br>0x1: Enabled |

**RX3 (0x2F)**

| BIT         | 7 | 6 | 5 | 4                  | 3 | 2 | 1 | 0 |
|-------------|---|---|---|--------------------|---|---|---|---|
| Field       | - | - | - | LINK_PRBS_CHK_PAM4 | - | - | - | - |
| Reset       | - | - | - | 0b0                | - | - | - | - |
| Access Type | - | - | - | Write, Read        | - | - | - | - |

| BITFIELD           | BITS | DESCRIPTION   | DECODE                                   |
|--------------------|------|---|--|
| LINK_PRBS_CHK_PAM4 | 4    | Enable link PRBS-7 checker for PAM4 mode, enable this register before prbs generator is enabled on the remote side. Keep default value for NRZ. | 0x0: Driven from A<br>0x1: Driven from B |

**GPIOA (0x30)**

| BIT         | 7 | 6 | 5                  | 4 | 3 | 2 | 1 | 0 |
|-------------|---|---|--------------------|---|---|---|---|---|
| Field       | - | - | GPIO_FWD_CDLY[5:0] |   |   |   |   |   |
| Reset       | - | - | 0b000001           |   |   |   |   |   |
| Access Type | - | - | Write, Read        |   |   |   |   |   |

| BITFIELD      | BITS | DESCRIPTION  | DECODE  |
|---------------|------|--|---|
| GPIO_FWD_CDLY | 5:0  | Compensation delay multiplier for the forward direction. For Link A.<br><br>This must be the same value as GPIO_FWD_CDLY of the chip on the other side of the link.<br><br>Total delay is the (value + 1) multiplied by 1.7µs. Default delay is 3.4µs. | 0bXXXXXX: Forward compensation delay multiplier value |

**GPIOB (0x31)**

| BIT   | 7                 | 6 | 5                  | 4 | 3 | 2 | 1 | 0 |
|-------|-------------------|---|--------------------|---|---|---|---|---|
| Field | GPIO_TX_WNDW[1:0] |   | GPIO_REV_CDLY[5:0] |   |   |   |   |   |
| Reset | 0b10              |   | 0b001000           |   |   |   |   |   |

|                    |             |             |
|--------------------|-------------|-------------|
| <b>Access Type</b> | Write, Read | Write, Read |
|--------------------|-------------|-------------|

| BITFIELD      | BITS | DESCRIPTION   | DECODE   |
|---------------|------|---|--|
| GPIO_TX_WNDW  | 7:6  | Wait time after a GPIO transition to create a packet. For Link A.<br><br>This allows grouping transitions of different GPIO inputs in a single packet and so increases GPIO bandwidth usage efficiency.   | 0b00: Disabled<br>0b01: 200ns<br>0b10: 500ns<br>0b11: 1000ns |
| GPIO_REV_CDLY | 5:0  | Compensation delay multiplier for the reverse direction. For Link A.<br><br>This must be the same value as GPIO_REV_CDLY of the chip on the other side of the link.<br><br>Total delay is the (value + 1) multiplied by 1.7µs. Default delay is 15.3µs. | 0bXXXXXX: Reverse compensation delay multiplier value        |

**I2C 0 (0x40)**

| BIT                | 7 | 6 | 5           | 4 | 3 | 2           | 1 | 0 |
|--------------------|---|---|-------------|---|---|-------------|---|---|
| <b>Field</b>       | – | – | SLV_SH[1:0] |   | – | SLV_TO[2:0] |   |   |
| <b>Reset</b>       | – | – | 0b10        |   | – | 0b110       |   |   |
| <b>Access Type</b> | – | – | Write, Read |   | – | Write, Read |   |   |

| BITFIELD | BITS | DESCRIPTION   | DECODE  |
|----------|------|---|---|
| SLV_SH   | 5:4  | I <sup>2</sup> C-to-I <sup>2</sup> C subordinate-setup and hold-time setting.<br><br>Configures the interval between SDA and SCL transitions when driven by the internal I <sup>2</sup> C subordinate.  | 0b00: Set for I <sup>2</sup> C Fast-mode Plus speed (1Mbps)<br>0b01: Set for I <sup>2</sup> C Fast-mode speed (400Kbps)<br>0b10: Set for I <sup>2</sup> C standard-mode speed (100Kbps)<br>0b11: Reserved |
| SLV_TO   | 2:0  | I <sup>2</sup> C-to-I <sup>2</sup> C subordinate timeout setting.<br><br>Internal GMSL2 I <sup>2</sup> C subordinate times out after the configured duration if it does not receive any response while waiting for a packet from remote device. | 0b000: 16µs<br>0b001: 1ms<br>0b010: 2ms<br>0b011: 4ms<br>0b100: 8ms<br>0b101: 16ms<br>0b110: 32ms<br>0b111: Disabled  |

**I2C 1 (0x41)**

| BIT          | 7 | 6           | 5 | 4 | 3 | 2           | 1 | 0 |
|--------------|---|-------------|---|---|---|-------------|---|---|
| <b>Field</b> | – | MST_BT[2:0] |   |   | – | MST_TO[2:0] |   |   |

|                    |   |             |   |             |
|--------------------|---|-------------|---|-------------|
| <b>Reset</b>       | – | 0b101       | – | 0b110       |
| <b>Access Type</b> | – | Write, Read | – | Write, Read |

| BITFIELD | BITS | DESCRIPTION   | DECODE  |
|----------|------|---|---|
| MST_BT   | 6:4  | <p>I<sup>2</sup>C-to-I<sup>2</sup>C main bit rate setting.</p> <p>Configures the I<sup>2</sup>C bit rate used by the internal I<sup>2</sup>C main (in the device on the remote side from the external I<sup>2</sup>C main).</p> <p>Set this according to the I<sup>2</sup>C speed mode.</p> | <p>0b000: 9.92Kbps - Set for I<sup>2</sup>C Standard mode speed</p> <p>0b001: 33.2Kbps - Set for I<sup>2</sup>C Standard mode speed</p> <p>0b010: 99.2Kbps - Set for I<sup>2</sup>C Standard or Fast-mode speed</p> <p>0b011: 123Kbps - Set for I<sup>2</sup>C Fast-mode speed</p> <p>0b100: 203Kbps - Set for I<sup>2</sup>C Fast-mode speed</p> <p>0b101: 397Kbps - Set for I<sup>2</sup>C Fast or Fast-mode Plus speed</p> <p>0b110: 625Kbps - Set for I<sup>2</sup>C Fast-mode Plus speed</p> <p>0b111: 980Kbps - Set for I<sup>2</sup>C Fast-mode Plus speed</p> |
| MST_TO   | 2:0  | <p>I<sup>2</sup>C-to-I<sup>2</sup>C main timeout setting.</p> <p>Internal GMSL2 I<sup>2</sup>C main times out after the configured duration if it does not receive any response while waiting for a packet from remote device.</p>  | <p>0b000: 16μs</p> <p>0b001: 1ms</p> <p>0b010: 2ms</p> <p>0b011: 4ms</p> <p>0b100: 8ms</p> <p>0b101: 16ms</p> <p>0b110: 32ms</p> <p>0b111: Disabled</p>   |

**I2C 2 (0x42)**

|                    |             |          |          |          |          |          |          |          |
|--------------------|-------------|----------|----------|----------|----------|----------|----------|----------|
| <b>BIT</b>         | <b>7</b>    | <b>6</b> | <b>5</b> | <b>4</b> | <b>3</b> | <b>2</b> | <b>1</b> | <b>0</b> |
| <b>Field</b>       | SRC_A[6:0]  |          |          |          |          |          |          | –        |
| <b>Reset</b>       | 0b0000000   |          |          |          |          |          |          | –        |
| <b>Access Type</b> | Write, Read |          |          |          |          |          |          | –        |

| BITFIELD | BITS | DESCRIPTION   | DECODE                                     |
|----------|------|---|--|
| SRC_A    | 7:1  | <p>I<sup>2</sup>C address translator source A for main control channel.</p> <p>When an I<sup>2</sup>C transaction across the GMSL link has a device address matching I<sup>2</sup>C SRC_A, the device address as seen on the remote side is replaced by the device address in I<sup>2</sup>C DST_A.</p> | 0bXXXXXXX: Value of I <sup>2</sup> C SRC_A |

**I2C 3 (0x43)**

|              |            |          |          |          |          |          |          |          |
|--------------|------------|----------|----------|----------|----------|----------|----------|----------|
| <b>BIT</b>   | <b>7</b>   | <b>6</b> | <b>5</b> | <b>4</b> | <b>3</b> | <b>2</b> | <b>1</b> | <b>0</b> |
| <b>Field</b> | DST_A[6:0] |          |          |          |          |          |          | –        |
| <b>Reset</b> | 0b0000000  |          |          |          |          |          |          | –        |

|                    |             |   |
|--------------------|-------------|---|
| <b>Access Type</b> | Write, Read | – |
|--------------------|-------------|---|

| <b>BITFIELD</b> | <b>BITS</b> | <b>DESCRIPTION</b>  | <b>DECODE</b>                               |
|-----------------|-------------|---|---|
| DST_A           | 7:1         | I <sup>2</sup> C address translator destination A for main control channel.<br><br>See the description of I <sup>2</sup> C SRC_A. | 0bXXXXXXXX: Value of I <sup>2</sup> C DST_A |

**I2C 4 (0x44)**

| <b>BIT</b>         | <b>7</b>    | <b>6</b> | <b>5</b> | <b>4</b> | <b>3</b> | <b>2</b> | <b>1</b> | <b>0</b> |
|--------------------|-------------|----------|----------|----------|----------|----------|----------|----------|
| <b>Field</b>       | SRC_B[6:0]  |          |          |          |          |          |          | –        |
| <b>Reset</b>       | 0b0000000   |          |          |          |          |          |          | –        |
| <b>Access Type</b> | Write, Read |          |          |          |          |          |          | –        |

| <b>BITFIELD</b> | <b>BITS</b> | <b>DESCRIPTION</b>   | <b>DECODE</b>                               |
|-----------------|-------------|--|---|
| SRC_B           | 7:1         | I <sup>2</sup> C address translator source B for main control channel.<br><br>When an I <sup>2</sup> C transaction across the GMSL link has a device address matching I <sup>2</sup> C SRC_B, the device address as seen on the remote side is replaced by the device address in I <sup>2</sup> C DST_B. | 0bXXXXXXXX: Value of I <sup>2</sup> C SRC_B |

**I2C 5 (0x45)**

| <b>BIT</b>         | <b>7</b>    | <b>6</b> | <b>5</b> | <b>4</b> | <b>3</b> | <b>2</b> | <b>1</b> | <b>0</b> |
|--------------------|-------------|----------|----------|----------|----------|----------|----------|----------|
| <b>Field</b>       | DST_B[6:0]  |          |          |          |          |          |          | –        |
| <b>Reset</b>       | 0b0000000   |          |          |          |          |          |          | –        |
| <b>Access Type</b> | Write, Read |          |          |          |          |          |          | –        |

| <b>BITFIELD</b> | <b>BITS</b> | <b>DESCRIPTION</b>  | <b>DECODE</b>                               |
|-----------------|-------------|---|---|
| DST_B           | 7:1         | I <sup>2</sup> C address translator destination B for main control channel.<br><br>See the description of I <sup>2</sup> C SRC_B. | 0bXXXXXXXX: Value of I <sup>2</sup> C DST_B |

**I2C 7 (0x47)**

| BIT         | 7                | 6                | 5 | 4 | 3 | 2               | 1             | 0             |
|-------------|------------------|------------------|---|---|---|-----------------|---------------|---------------|
| Field       | UART_RX_OVERFLOW | UART_TX_OVERFLOW | – | – | – | I2C_TIMED_OUT   | REM_ACK_ACKED | REM_ACK_RECVD |
| Reset       | 0b0              | 0b0              | – | – | – | 0b0             | 0b0           | 0b0           |
| Access Type | Read Clears All  | Read Clears All  | – | – | – | Read Clears All | Read Only     | Read Only     |

| BITFIELD         | BITS | DESCRIPTION   | DECODE  |
|------------------|------|---|---|
| UART_RX_OVERFLOW | 7    | Flag to indicate overflow of the UART FIFO that holds data to receive from the GMSL link                                      | 0b0: No overflow occurred<br>0b1: Overflow occurred |
| UART_TX_OVERFLOW | 6    | Flag to indicate overflow of the UART FIFO that holds data to transmit across the GMSL link                                   | 0b0: No overflow occurred<br>0b1: Overflow occurred |
| I2C_TIMED_OUT    | 2    | Internal I <sup>2</sup> C-to-I <sup>2</sup> C subordinate or main has timed out while receiving packet from remote device     | 0b0: No timeout occurred<br>0b1: Timeout occurred   |
| REM_ACK_ACKED    | 1    | Inverse of the I <sup>2</sup> C Ack Bit received from remote side. Set to 1 when the Ack is received.                         | 0b0: Ack not received<br>0b1: Ack received          |
| REM_ACK_RECVD    | 0    | I <sup>2</sup> C Ack Bit for any I <sup>2</sup> C byte is received from remote side for the previous I <sup>2</sup> C packet. | 0b0: Ack not received<br>0b1: Ack received          |

**UART 0 (0x48)**

| BIT         | 7 | 6 | 5           | 4           | 3              | 2              | 1 | 0           |
|-------------|---|---|-------------|-------------|----------------|----------------|---|-------------|
| Field       | – | – | REM_MS_EN   | LOC_MS_EN   | BYPASS_DIS_PAR | BYPASS_TO[1:0] |   | BYPASS_EN   |
| Reset       | – | – | 0b0         | 0b0         | 0b0            | 0b01           |   | 0b0         |
| Access Type | – | – | Write, Read | Write, Read | Write, Read    | Write, Read    |   | Write, Read |

| BITFIELD  | BITS | DESCRIPTION  | DECODE  |
|-----------|------|--|---|
| REM_MS_EN | 5    | <p>Enables UART Bypass Mode Control by Remote GPIO Pin</p> <p>When set, remote chip's GPIO is used as MS pin (UART mode select).</p> <p>When MS is high, chip is in Bypass mode; otherwise, it is in Base mode.</p> <p>In Bypass mode, the UART interface can only access an external UART interface through the MFP pins and cannot access the control channel.</p> | <p>0b0: UART Bypass mode not controlled by remote MS pin</p> <p>0b1: UART Bypass mode controlled by remote MS pin</p> |

| BITFIELD       | BITS | DESCRIPTION   | DECODE  |
|----------------|------|---|---|
|                |      | In Base mode, the control channel access is enabled.  |   |
| LOC_MS_EN      | 4    | <p>Enables UART Bypass mode control by local GPIO pin.</p> <p>Set to use GPIO2 pin as MS pin (UART mode select).</p> <p>When MS is high, chip is in Bypass mode; otherwise, chip is in Base mode.</p> <p>In Bypass mode, the UART interface can only access an external UART interface through the MFP pins and cannot access the control channel. In Base mode, the control channel access is enabled.</p> | <p>0b0: UART bypass mode not controlled by local MS pin</p> <p>0b1: UART bypass mode controlled by local MS pin</p>         |
| BYPASS_DIS_PAR | 3    | Selects whether or not to receive and send parity bit in Bypass mode.   | <p>0b0: Receive and send parity bit in Bypass mode</p> <p>0b1: Do not receive and send parity bit in Bypass mode</p>        |
| BYPASS_TO      | 2:1  | <p>UART Soft-Bypass Timeout Duration</p> <p>When set to 11, BYPASS_EN is never cleared, so the device stays in Bypass mode until the next power down.</p>   | <p>0b00: 2ms</p> <p>0b01: 8ms</p> <p>0b10: 32ms</p> <p>0b11: Disabled (bypass mode active until next power cycle/PWDNB)</p> |
| BYPASS_EN      | 0    | <p>Enable UART Soft-Bypass Mode</p> <p>Bypass mode remains active as long as there is UART activity.</p> <p>When there is no UART activity for the selected duration (configured by BYPASS_TO bitfield), device exits Bypass mode, and the bit is automatically cleared.</p>  | <p>0b0: UART soft-bypass mode disabled</p> <p>0b1: UART soft-bypass mode enabled</p>  |

### UART 1 (0x49)

| BIT         | 7               | 6 | 5 | 4 | 3 | 2 | 1 | 0 |
|-------------|-----------------|---|---|---|---|---|---|---|
| Field       | BITLEN_LSB[7:0] |   |   |   |   |   |   |   |
| Reset       | 0x96            |   |   |   |   |   |   |   |
| Access Type | Read Only       |   |   |   |   |   |   |   |

| BITFIELD   | BITS | DESCRIPTION  | DECODE                                     |
|------------|------|--|--|
| BITLEN_LSB | 7:0  | UART detected bit length, low 8 bits. Detected UART pin BAUD rate in terms of 150MHz clock cycles. | 0xXX: UART detected bit length, low 8 bits |

**UART 2 (0x4A)**

| BIT         | 7              | 6 | 5               | 4 | 3 | 2 | 1 | 0 |
|-------------|----------------|---|-----------------|---|---|---|---|---|
| Field       | OUT_DELAY[1:0] |   | BITLEN_MSB[5:0] |   |   |   |   |   |
| Reset       | 0b10           |   | 0b000000        |   |   |   |   |   |
| Access Type | Write, Read    |   | Read Only       |   |   |   |   |   |

| BITFIELD   | BITS | DESCRIPTION  | DECODE  |
|------------|------|--|---|
| OUT_DELAY  | 7:6  | UART initial output delay<br>In Base mode, first received UART byte of a packet (Sync or Ack frame) is delayed by the configured number of bit times to output the UART frames of the same packet back-to-back on the remote side. This delay avoids a gap between the first byte and remaining bytes. | 0b00: Do not wait<br>0b01: Wait for 4 bits<br>0b10: Wait for 8 bits<br>0b11: Wait for 1 bit |
| BITLEN_MSB | 5:0  | UART detected bit length, high 6 bits. Detected UART pin BAUD rate in terms of 150MHz clock cycles.  | 0xXX: UART detected bit length, upper 6 bits  |

**I2C\_PT\_0 (0x4C)**

| BIT         | 7 | 6 | 5              | 4 | 3 | 2              | 1 | 0 |
|-------------|---|---|----------------|---|---|----------------|---|---|
| Field       | – | – | SLV_SH_PT[1:0] |   | – | SLV_TO_PT[2:0] |   |   |
| Reset       | – | – | 0b10           |   | – | 0b110          |   |   |
| Access Type | – | – | Write, Read    |   | – | Write, Read    |   |   |

| BITFIELD  | BITS | DESCRIPTION  | DECODE  |
|-----------|------|--|---|
| SLV_SH_PT | 5:4  | Pass-Through 1 and 2 I <sup>2</sup> C-to-I <sup>2</sup> C Subordinate Setup and Hold-Time Setting (Setup, Hold)<br><br>Configures the interval between SDA and SCL transitions when driven by the internal I <sup>2</sup> C subordinate. | 0b00: Set for I <sup>2</sup> C Fast-mode Plus speed (1Mbps)<br>0b01: Set for I <sup>2</sup> C Fast-mode speed (400Kbps)<br>0b10: Set for I <sup>2</sup> C Standard-mode speed (100Kbps)<br>0b11: Reserved |

| BITFIELD  | BITS | DESCRIPTION  | DECODE  |
|-----------|------|--|---|
| SLV_TO_PT | 2:0  | <p>Pass-Through 1 and 2 I<sup>2</sup>C-to-I<sup>2</sup>C Subordinate Timeout Setting</p> <p>Internal GMSL2 I<sup>2</sup>C subordinate times out after the configured duration if it does not receive any response while waiting for a packet from remote device.</p> | <p>0b000: 16µs<br/>                     0b001: 1ms<br/>                     0b010: 2ms<br/>                     0b011: 4ms<br/>                     0b100: 8ms<br/>                     0b101: 16ms<br/>                     0b110: 32ms<br/>                     0b111: Disabled</p> |

**I2C\_PT\_1 (0x4D)**

| BIT         | 7 | 6              | 5 | 4 | 3 | 2              | 1 | 0 |
|-------------|---|----------------|---|---|---|----------------|---|---|
| Field       | – | MST_BT_PT[2:0] |   |   | – | MST_TO_PT[2:0] |   |   |
| Reset       | – | 0b101          |   |   | – | 0b110          |   |   |
| Access Type | – | Write, Read    |   |   | – | Write, Read    |   |   |

| BITFIELD  | BITS | DESCRIPTION  | DECODE  |
|-----------|------|--|---|
| MST_BT_PT | 6:4  | <p>Pass-Through 1 and 2 I<sup>2</sup>C-to-I<sup>2</sup>C Main Bit-Rate Setting</p> <p>Configures the I<sup>2</sup>C bit rate (SCL clock frequency) used by the internal I<sup>2</sup>C main (in the device on the remote side from the external I<sup>2</sup>C main).</p> <p>Set according to the I<sup>2</sup>C speed mode.</p> | <p>0b000: 9.92Kbps - Set for I<sup>2</sup>C Standard mode speed<br/>                     0b001: 33.2Kbps - Set for I<sup>2</sup>C Standard mode speed<br/>                     0b010: 99.2Kbps - Set for I<sup>2</sup>C Standard or Fast-mode speed<br/>                     0b011: 123Kbps - Set for I<sup>2</sup>C Fast-mode speed<br/>                     0b100: 203Kbps - Set for I<sup>2</sup>C Fast-mode speed<br/>                     0b101: 397Kbps - Set for I<sup>2</sup>C Fast or Fast-mode Plus speed<br/>                     0b110: 625Kbps - Set for I<sup>2</sup>C Fast-mode Plus speed<br/>                     0b111: 980Kbps - Set for I<sup>2</sup>C Fast-mode Plus speed</p> |
| MST_TO_PT | 2:0  | <p>Pass-Through 1 and 2 I<sup>2</sup>C-to-I<sup>2</sup>C Main Timeout Setting</p> <p>Internal GMSL2 I<sup>2</sup>C main times out after the configured duration if it does not receive any response while waiting for a packet from the remote device.</p>   | <p>0b000: 16µs<br/>                     0b001: 1ms<br/>                     0b010: 2ms<br/>                     0b011: 4ms<br/>                     0b100: 8ms<br/>                     0b101: 16ms<br/>                     0b110: 32ms<br/>                     0b111: Disabled</p>   |

**I2C\_PT\_2 (0x4E)**

| BIT         | 7 | 6               | 5 | 4 | 3 | 2               | 1 | 0 |
|-------------|---|-----------------|---|---|---|-----------------|---|---|
| Field       | – | I2C_TIMED_OUT_2 | – | – | – | I2C_TIMED_OUT_1 | – | – |
| Reset       | – | 0b0             | – | – | – | 0b0             | – | – |
| Access Type | – | Read Clears All | – | – | – | Read Clears All | – | – |

| BITFIELD        | BITS | DESCRIPTION   |
|-----------------|------|---|
| I2C_TIMED_OUT_2 | 6    | In pass-through I <sup>2</sup> C channel 2, internal I <sup>2</sup> C-to-I <sup>2</sup> C subordinate or main has timed out while receiving packet from remote device |
| I2C_TIMED_OUT_1 | 2    | In pass-through I <sup>2</sup> C channel 1, internal I <sup>2</sup> C-to-I <sup>2</sup> C subordinate or main has timed out while receiving packet from remote device |

**UART\_PT\_0 (0x4F)**

| BIT         | 7                | 6           | 5 | 4 | 3                | 2           | 1 | 0 |
|-------------|------------------|-------------|---|---|------------------|-------------|---|---|
| Field       | BITLEN_MAN_CFG_2 | DIS_PAR_2   | – | – | BITLEN_MAN_CFG_1 | DIS_PAR_1   | – | – |
| Reset       | 0b1              | 0b0         | – | – | 0b1              | 0b0         | – | – |
| Access Type | Write, Read      | Write, Read | – | – | Write, Read      | Write, Read | – | – |

| BITFIELD         | BITS | DESCRIPTION  | DECODE   |
|------------------|------|--|--|
| BITLEN_MAN_CFG_2 | 7    | Use the custom UART bit rate (selected by the BITLEN_PT_2_L - 0x548 and BITLEN_PT_2_H - 0x549 bitfields) in pass-through UART Channel 1. | 0b0: Use standard bit rate<br>0b1: Use custom bit rate |
| DIS_PAR_2        | 6    | Disable parity bit in pass-through UART Channel 2  | 0b0: Parity bit enabled<br>0b1: Parity bit disabled    |
| BITLEN_MAN_CFG_1 | 3    | Use the custom UART bit rate (selected by the BITLEN_PT_1_L - 0x54A and BITLEN_PT_1_H - 0x54B bitfields) in pass-through UART Channel 1. | 0b0: Use standard bit rate<br>0b1: Use custom bit rate |
| DIS_PAR_1        | 2    | Disable parity bit in pass-through UART Channel 1  | 0b0: Parity bit enabled<br>0b1: Parity bit disabled    |

**RX0 (0x50)**

| BIT         | 7           | 6 | 5 | 4 | 3 | 2 | 1            | 0 |
|-------------|-------------|---|---|---|---|---|--------------|---|
| Field       | RX_CRC_EN   | – | – | – | – | – | STR_SEL[1:0] |   |
| Reset       | 0b0         | – | – | – | – | – | 0b00         |   |
| Access Type | Write, Read | – | – | – | – | – | Write, Read  |   |

| BITFIELD  | BITS | DESCRIPTION   | DECODE  |
|-----------|------|---|---|
| RX_CRC_EN | 7    | When set, indicates that packets received at this port have appended CRC and CRC checking should be performed at each packet. | 0b0: No CRC on received packets<br>0b1: Received packets have CRC and checking is enabled |
| STR_SEL   | 1:0  | Reserved. Do not use (legacy). Use register 0x161 VIDEO_PIPE_SEL instead.   |   |

**RX0 (0x51)**

| BIT         | 7           | 6 | 5 | 4 | 3 | 2 | 1            | 0 |
|-------------|-------------|---|---|---|---|---|--------------|---|
| Field       | RX_CRC_EN   | – | – | – | – | – | STR_SEL[1:0] |   |
| Reset       | 0b0         | – | – | – | – | – | 0b01         |   |
| Access Type | Write, Read | – | – | – | – | – | Write, Read  |   |

| BITFIELD  | BITS | DESCRIPTION   | DECODE  |
|-----------|------|---|---|
| RX_CRC_EN | 7    | When set, indicates that packets received at this port have appended CRC and CRC checking should be performed at each packet. | 0b0: No CRC on received packets<br>0b1: Received packets have CRC and checking is enabled |
| STR_SEL   | 1:0  | Reserved. Do not use (legacy). Use register 0x161 VIDEO_PIPE_SEL instead.   |   |

**RX0 (0x52)**

| BIT         | 7           | 6 | 5 | 4 | 3 | 2 | 1            | 0 |
|-------------|-------------|---|---|---|---|---|--------------|---|
| Field       | RX_CRC_EN   | – | – | – | – | – | STR_SEL[1:0] |   |
| Reset       | 0b0         | – | – | – | – | – | 0b10         |   |
| Access Type | Write, Read | – | – | – | – | – | Write, Read  |   |

| BITFIELD  | BITS | DESCRIPTION   | DECODE  |
|-----------|------|---|---|
| RX_CRC_EN | 7    | When set, indicates that packets received at this port have appended CRC and CRC checking should be performed at each packet. | 0b0: No CRC on received packets<br>0b1: Received packets have CRC and checking is enabled |
| STR_SEL   | 1:0  | Reserved. Do not use (legacy). Use register 0x161 VIDEO_PIPE_SEL instead.   |   |

**RX0 (0x53)**

| BIT | 7 | 6 | 5 | 4 | 3 | 2 | 1 | 0 |
|-----|---|---|---|---|---|---|---|---|
|-----|---|---|---|---|---|---|---|---|

|                    |             |   |   |   |   |   |              |
|--------------------|-------------|---|---|---|---|---|--------------|
| <b>Field</b>       | RX_CRC_EN   | – | – | – | – | – | STR_SEL[1:0] |
| <b>Reset</b>       | 0b0         | – | – | – | – | – | 0b11         |
| <b>Access Type</b> | Write, Read | – | – | – | – | – | Write, Read  |

| BITFIELD  | BITS | DESCRIPTION   | DECODE  |
|-----------|------|---|---|
| RX_CRC_EN | 7    | When set, indicates that packets received at this port have appended CRC and CRC checking should be performed at each packet. | 0b0: No CRC on received packets<br>0b1: Received packets have CRC and checking is enabled |
| STR_SEL   | 1:0  | Reserved. Do not use (legacy). Use register 0x161 VIDEO_PIPE_SEL instead.   |   |

### TR0 (0x60, 0x68, 0x78)

| BIT                | 7           | 6           | 5 | 4 | 3             | 2 | 1             | 0 |
|--------------------|-------------|-------------|---|---|---------------|---|---------------|---|
| <b>Field</b>       | TX_CRC_EN   | RX_CRC_EN   | – | – | PRIO_VAL[1:0] |   | PRIO_CFG[1:0] |   |
| <b>Reset</b>       | 0b1         | 0b1         | – | – | 0b00          |   | 0b00          |   |
| <b>Access Type</b> | Write, Read | Write, Read | – | – | Write, Read   |   | Write, Read   |   |

| BITFIELD  | BITS | DESCRIPTION   | DECODE   |
|-----------|------|---|--|
| TX_CRC_EN | 7    | When set, calculate and append CRC to each packet transmitted from this port  | 0b0: Transmit CRC disabled<br>0b1: Transmit CRC enabled  |
| RX_CRC_EN | 6    | When set, indicates that packets received at this port have appended CRC and CRC checking should be performed at each packet. | 0b0: Receive CRC disabled<br>0b1: Receive CRC enabled  |
| PRIO_VAL  | 3:2  | Sets the priority for this channel's packet requests  | 0b00: Low priority<br>0b01: Normal priority<br>0b10: High priority<br>0b11: Urgent priority  |
| PRIO_CFG  | 1:0  | Adjust the priority used for this channel   | 0b00: Current channel priority is used<br>0b01: Increase current channel priority<br>0b10: Decrease current channel priority<br>0b11: Reset to channel PRIO_VAL[1:0] setting |

### TR1 (0x61, 0x69, 0x71, 0x79, 0x81, 0x89)

| BIT                | 7            | 6 | 5           | 4 | 3 | 2 | 1 | 0 |
|--------------------|--------------|---|-------------|---|---|---|---|---|
| <b>Field</b>       | BW_MULT[1:0] |   | BW_VAL[5:0] |   |   |   |   |   |
| <b>Reset</b>       | 0b10         |   | 0b110000    |   |   |   |   |   |
| <b>Access Type</b> | Write, Read  |   | Write, Read |   |   |   |   |   |

| BITFIELD | BITS | DESCRIPTION  | DECODE   |
|----------|------|--|--|
| BW_MULT  | 7:6  | Channel bandwidth-allocation multiplication factor   | 0b00: Multiply BW_VAL by 1<br>0b01: Multiply BW_VAL by 4<br>0b10: Multiply BW_VAL by 16<br>0b11: Multiply BW_VAL by 16 |
| BW_VAL   | 5:0  | Channel bandwidth-allocation base. Used to calculate percentage of total link bandwidth used for this port.<br><br>Fair bandwidth use ratio = BW_VAL x BW_MULT/10 as a percentage of total link bandwidth. | 0bXXXXXX: Channel base-bandwidth value   |

**TR3 (0x63, 0x6B, 0x73, 0x7B, 0x83, 0x8B)**

| BIT         | 7 | 6 | 5 | 4 | 3 | 2              | 1 | 0 |
|-------------|---|---|---|---|---|----------------|---|---|
| Field       | - | - | - | - | - | TX_SRC_ID[2:0] |   |   |
| Reset       | - | - | - | - | - | 0b000          |   |   |
| Access Type | - | - | - | - | - | Write, Read    |   |   |

| BITFIELD  | BITS | DESCRIPTION   | DECODE   |
|-----------|------|---|--|
| TX_SRC_ID | 2:0  | Source identifier used in packets transmitted from this channel.<br><br>Default value is based on the device address set by the CFG0 pin. | 0bXXX: Source ID for packets from this channel |

**TR4 (0x64, 0x6C, 0x74, 0x7C, 0x84, 0x8C)**

| BIT         | 7               | 6 | 5 | 4 | 3 | 2 | 1 | 0 |
|-------------|-----------------|---|---|---|---|---|---|---|
| Field       | RX_SRC_SEL[7:0] |   |   |   |   |   |   |   |
| Reset       | 0xFF            |   |   |   |   |   |   |   |
| Access Type | Write, Read     |   |   |   |   |   |   |   |

| BITFIELD   | BITS | DESCRIPTION  | DECODE  |
|------------|------|--|---|
| RX_SRC_SEL | 7:0  | Receive packets from selected sources.<br><br>Each bit indicates if packets with that source ID should be received or not. This is a one-hot encoding.<br><br>For example, when SRC_SEL = 00001001, then | 0x00: No packets received<br>0x01: Packets from source ID 0 received<br>0x02: Packets from source ID 1 received<br>0x03: Packets from source ID 0 and 1 received<br>0x04: Packets from source ID 2 received<br>...<br>...<br>0xFF: Packets from all source IDs received |

| BITFIELD | BITS | DESCRIPTION   | DECODE |
|----------|------|---|--------|
|          |      | packets with source ID equal to 0 and 3 are received. |        |

**ARQ0 (0x6D, 0x75, 0x7D, 0x85, 0x8D)**

| BIT         | 7 | 6 | 5            | 4           | 3           | 2                | 1 | 0 |
|-------------|---|---|--------------|-------------|-------------|------------------|---|---|
| Field       | – | – | MATCH_SRC_ID | ACK_SRC_ID  | EN          | DIS_DBL_ACK_RETX | – | – |
| Reset       | – | – | 0b0          | 0b1         | 0b1         | 0b0              | – | – |
| Access Type | – | – | Write, Read  | Write, Read | Write, Read | Write, Read      | – | – |

| BITFIELD         | BITS | DESCRIPTION   | DECODE  |
|------------------|------|---|---|
| MATCH_SRC_ID     | 5    | Ack packet source ID checking method                            | 0: All received Ack packets are accepted<br>1: Ack packet is accepted if SRC_ID of the received Ack packet matches TX_SRC_ID register |
| ACK_SRC_ID       | 4    | Select what to use as SRC_ID in transmitted Ack packets         | 0: Use SRC_ID of the received data packet<br>1: Use TX_SRC_ID register  |
| EN               | 3    | Enable ARQ  | 0b0: ARQ disabled<br>0b1: ARQ enabled   |
| DIS_DBL_ACK_RETX | 2    | Disable retransmission due to receiving same acknowledge twice. | 0b0: Enabled<br>0b1: Disabled   |

**ARQ1 (0x6E, 0x76, 0x7E, 0x86, 0x8E)**

| BIT         | 7 | 6           | 5 | 4 | 3 | 2 | 1              | 0           |
|-------------|---|-------------|---|---|---|---|----------------|-------------|
| Field       | – | MAX_RT[2:0] |   |   | – | – | MAX_RT_ERR_OEN | RT_CNT_OEN  |
| Reset       | – | 0b111       |   |   | – | – | 0b1            | 0b0         |
| Access Type | – | Write, Read |   |   | – | – | Write, Read    | Write, Read |

| BITFIELD       | BITS | DESCRIPTION   | DECODE  |
|----------------|------|---|---|
| MAX_RT         | 6:4  | Maximum retransmit limit. ARQ stops retransmitting after trying retransmission after this many times for a single packet. | 0bXXX: Binary value for number of times to retransmit   |
| MAX_RT_ERR_OEN | 1    | Enable reporting of ARQ maximum retransmission limit errors (MAX_RT_ERR - 0x616) for this channel at ERRB pin.            | 0b0: ARQ maximum retransmit limit errors reporting at ERRB pin disabled<br>0b1: ARQ maximum retransmit limit errors reporting at ERRB pin enabled |
| RT_CNT_OEN     | 0    | Enable reporting of ARQ retransmission event for this channel at ERRB pin.  | 0b0: ARQ retransmission count reporting at ERRB pin disabled<br>0b1: ARQ retransmission count reporting at ERRB pin enabled                       |

| BITFIELD | BITS | DESCRIPTION   | DECODE |
|----------|------|---|--------|
|          |      | When enabled, ERRB is asserted when RT_CNT of this channel is greater than 0. |        |

**ARQ2 (0x6F, 0x77, 0x7F, 0x87, 0x8F)**

| BIT         | 7               | 6               | 5 | 4 | 3 | 2 | 1 | 0 |
|-------------|-----------------|-----------------|---|---|---|---|---|---|
| Field       | MAX_RT_ERR      | RT_CNT[6:0]     |   |   |   |   |   |   |
| Reset       | 0b0             | 0b0000000       |   |   |   |   |   |   |
| Access Type | Read Clears All | Read Clears All |   |   |   |   |   |   |

| BITFIELD   | BITS | DESCRIPTION   | DECODE   |
|------------|------|---|--|
| MAX_RT_ERR | 7    | Reached maximum retransmission limit (MAX_RT) for one packet in this channel. | 0b0: Maximum retransmission limit not reached<br>0b1: Maximum retransmission limit reached |
| RT_CNT     | 6:0  | Total retransmission count in this channel.                                   | 0xXX: Count of retransmissions for this channel  |

**TR0 (0x70, 0x80, 0x88)**

| BIT         | 7           | 6           | 5 | 4 | 3             | 2 | 1             | 0 |
|-------------|-------------|-------------|---|---|---------------|---|---------------|---|
| Field       | TX_CRC_EN   | RX_CRC_EN   | – | – | PRIO_VAL[1:0] |   | PRIO_CFG[1:0] |   |
| Reset       | 0b1         | 0b1         | – | – | 0b00          |   | 0b00          |   |
| Access Type | Write, Read | Write, Read | – | – | Write, Read   |   | Write, Read   |   |

| BITFIELD  | BITS | DESCRIPTION   | DECODE   |
|-----------|------|---|--|
| TX_CRC_EN | 7    | When set, calculate and append CRC to each packet transmitted from this port  | 0b0: Transmit CRC disabled<br>0b1: Transmit CRC enabled  |
| RX_CRC_EN | 6    | When set, indicates that packets received at this port have appended CRC and CRC checking should be performed at each packet. | 0b0: Receive CRC disabled<br>0b1: Receive CRC enabled  |
| PRIO_VAL  | 3:2  | Sets the priority for this channel's packet requests  | 0b00: Low priority<br>0b01: Normal priority<br>0b10: High priority<br>0b11: Urgent priority  |
| PRIO_CFG  | 1:0  | Adjust the priority used for this channel   | 0b00: Current channel priority is used<br>0b01: Increase current channel priority<br>0b10: Decrease current channel priority<br>0b11: Reset to channel PRIO_VAL[1:0] setting |

**VIDEO\_RX0 (0x112, 0x124)**

| BIT | 7 | 6 | 5 | 4 | 3 | 2 | 1 | 0 |
|-----|---|---|---|---|---|---|---|---|
|-----|---|---|---|---|---|---|---|---|

|                    |                    |   |   |   |   |              |             |             |
|--------------------|--------------------|---|---|---|---|--------------|-------------|-------------|
| <b>Field</b>       | LCRC_ERR           | – | – | – | – | LINE_CRC_SEL | LINE_CRC_EN | DIS_PKT_DET |
| <b>Reset</b>       | 0b0                | – | – | – | – | 0b0          | 0b1         | 0b0         |
| <b>Access Type</b> | Read Clears<br>All | – | – | – | – | Write, Read  | Write, Read | Write, Read |

| BITFIELD     | BITS | DESCRIPTION   | DECODE  |
|--------------|------|---|---|
| LCRC_ERR     | 7    | Video-Line CRC Error Flag   | 0b0: No video line CRC error detected<br>0b1: Video line CRC error detected |
| LINE_CRC_SEL | 2    | Line-CRC Trigger Selection  | 0: Use DE<br>1: Use HS  |
| LINE_CRC_EN  | 1    | Video-Line CRC Enable   | 0b0: Video line CRC disabled<br>0b1: Video line CRC enabled                 |
| DIS_PKT_DET  | 0    | <p>Disable Packet Detector.</p> <p>Can be used when LIM_HEART is set to 1, to prevent the video pipe from timing out and resetting when no video packets are sent during long blanking intervals.</p> <p>If the video is restarted with a different bpp when the packet detector is disabled, toggle this register or the video receive enable register to make sure the video link restarts.</p> | 0b0: Packet detector enabled<br>0b1: Packet detector disabled               |

**VIDEO\_RX3 (0x115, 0x127)**

|                    |          |             |           |           |           |             |             |             |
|--------------------|----------|-------------|-----------|-----------|-----------|-------------|-------------|-------------|
| <b>BIT</b>         | <b>7</b> | <b>6</b>    | <b>5</b>  | <b>4</b>  | <b>3</b>  | <b>2</b>    | <b>1</b>    | <b>0</b>    |
| <b>Field</b>       | –        | HD_TR_MODE  | DLOCKED   | VLOCKED   | HLOCKED   | DTRACKEN    | VTRACKEN    | HTRACKEN    |
| <b>Reset</b>       | –        | 0b1         | 0b0       | 0b0       | 0b0       | 0b0         | 0b0         | 0b0         |
| <b>Access Type</b> | –        | Write, Read | Read Only | Read Only | Read Only | Write, Read | Write, Read | Write, Read |

| BITFIELD   | BITS | DESCRIPTION  | DECODE  |
|------------|------|--|---|
| HD_TR_MODE | 6    | Selects whether HS, DE tracking is fully periodic or if it stops during vertical blanking during HV tracking   | 0b0: Allow only partial periodic HS,DE tracking (stops during vertical blanking)<br>0b1: Allow partial periodic and full periodic HS, DE tracking |
| DLOCKED    | 5    | DE tracking locked   | 0b0: DE tracking not locked<br>0b1: DE tracking locked  |
| VLOCKED    | 4    | VS tracking locked   | 0b0: VS tracking not locked<br>0b1: VS tracking locked  |
| HLOCKED    | 3    | HS tracking locked   | 0b0: HS tracking not locked<br>0b1: HS tracking locked  |
| DTRACKEN   | 2    | <p>DE tracking enable (disable if FSYNC = 1)</p> <p>The system observes DE pulses and when it locks on the pattern, it can compensate for a limited number of missing pulses or suppress glitches.</p> | 0b0: DE tracking disabled<br>0b1: DE tracking enabled   |

| BITFIELD | BITS | DESCRIPTION   | DECODE  |
|----------|------|---|---|
| VTRACKEN | 1    | VS tracking enable (disable if FSYNC = 1)<br><br>The system observes VS pulses and when it locks on the pattern, it can compensate for a limited number of missing pulses or suppress glitches. | 0b0: VS tracking disabled<br>0b1: VS tracking enabled       |
| HTRACKEN | 0    | HS tracking enable (disable if FSYNC = 1)<br><br>The system observes HS pulses and when it locks on the pattern, it can compensate for a limited number of missing pulses or suppress glitches. | 0b0: HSYNC tracking disabled<br>0b1: HSYNC tracking enabled |

**VIDEO\_RX6 (0x118, 0x12A)**

| BIT         | 7 | 6 | 5 | 4 | 3           | 2 | 1 | 0 |
|-------------|---|---|---|---|-------------|---|---|---|
| Field       | – | – | – | – | LIM_HEART   | – | – | – |
| Reset       | – | – | – | – | 0b0         | – | – | – |
| Access Type | – | – | – | – | Write, Read | – | – | – |

| BITFIELD  | BITS | DESCRIPTION  | DECODE  |
|-----------|------|--|---|
| LIM_HEART | 3    | Disable heartbeat during blanking. Heartbeat is periodic video sync packets sent from the serializer so that the deserializer video output can replicate the video timing as seen in the serializer input. It is not necessary for MIPI. | 0b0: Heartbeat enabled during blanking<br>0b1: Heartbeat disabled during blanking |

**VIDEO\_RX8 (0x11A, 0x12C)**

| BIT         | 7               | 6         | 5           | 4               | 3 | 2 | 1 | 0 |
|-------------|-----------------|-----------|-------------|-----------------|---|---|---|---|
| Field       | VID_BLK_LEN_ERR | VID_LOCK  | VID_PKT_DET | VID_SEQ_ERR     | – | – | – | – |
| Reset       | 0b0             | 0b0       | 0b0         | 0b0             | – | – | – | – |
| Access Type | Read Clears All | Read Only | Read Only   | Read Clears All | – | – | – | – |

| BITFIELD        | BITS | DESCRIPTION   | DECODE  |
|-----------------|------|---|---|
| VID_BLK_LEN_ERR | 7    | Video Rx video pixel data block-length error detected. A length mismatch happens when the received data length does not match what is expected for the video data bits per pixel. | 0b0: No error detected<br>0b1: Video Rx block-length error detected |
| VID_LOCK        | 6    | Video pipeline locked.<br><br>Can also read the following registers to check if   | 0b0: Video pipeline not locked<br>0b1: Video pipeline locked        |

| BITFIELD    | BITS | DESCRIPTION  | DECODE  |
|-------------|------|--|---|
|             |      | MIPI TX is outputting data: csi2_tx1/2_pkt_cnt, csi2_dup1/2_pkt_cnt, phy0/1/2/3_pkt_cnt.   |   |
| VID_PKT_DET | 5    | Sufficient video Rx packet throughput detected. When LIM_HEART=0, this is at least one video packet every 100us. When LIM_HEART=1, this is at least one video packet every 10ms. | 0b0: Not enough throughput<br>0b1: Sufficient throughput detected |
| VID_SEQ_ERR | 4    | Video Rx sequence error occurred. A sequence is an alternating 0 and 1 sent in the video packet headers. When a packet is dropped, there are two successive 0s or 1s.            | 0b0: No error detected<br>0b1: Error detected                     |

### VIDEO\_RX10 (0x11C, 0x12E)

| BIT         | 7               | 6             | 5 | 4 | 3 | 2 | 1 | 0 |
|-------------|-----------------|---------------|---|---|---|---|---|---|
| Field       | VID_OVERFLOW    | MASK_VIDEO_DE | - | - | - | - | - | - |
| Reset       | 0b0             | 0b0           | - | - | - | - | - | - |
| Access Type | Read Clears All | Write, Read   | - | - | - | - | - | - |

| BITFIELD      | BITS | DESCRIPTION  | DECODE  |
|---------------|------|--|---|
| VID_OVERFLOW  | 7    | Sticky bit for overflow detected in video Rx buffers, read to clear. | 0: No error detected<br>1: Error detected                   |
| MASK_VIDEO_DE | 6    | Masks video when DE is low   | 0x0: Do not mask when DE is low<br>0x1: Mask when DE is low |

### VIDEO\_PIPE\_EN (0x160)

| BIT         | 7 | 6 | 5 | 4 | 3 | 2 | 1                  | 0 |
|-------------|---|---|---|---|---|---|--------------------|---|
| Field       | - | - | - | - | - | - | VIDEO_PIPE_EN[1:0] |   |
| Reset       | - | - | - | - | - | - | 0b11               |   |
| Access Type | - | - | - | - | - | - | Write, Read        |   |

| BITFIELD      | BITS | DESCRIPTION             |
|---------------|------|-------------------------|
| VIDEO_PIPE_EN | 1:0  | Enables for video pipes |

### VIDEO\_PIPE\_SEL (0x161)

| BIT | 7 | 6 | 5 | 4 | 3 | 2 | 1 | 0 |
|-----|---|---|---|---|---|---|---|---|
|     |   |   |   |   |   |   |   |   |

|                    |   |   |                       |                       |
|--------------------|---|---|-----------------------|-----------------------|
| <b>Field</b>       | – | – | VIDEO_PIPE_SEL_Z[2:0] | VIDEO_PIPE_SEL_Y[2:0] |
| <b>Reset</b>       | – | – | 0b110                 | 0b010                 |
| <b>Access Type</b> | – | – | Write, Read           | Write, Read           |

| BITFIELD         | BITS | DESCRIPTION   | DECODE   |
|------------------|------|---|--|
| VIDEO_PIPE_SEL_Z | 5:3  | Selects the incoming stream ID to receive in Video Pipe Z | 0x0: Link A stream ID 00<br>0x1: Link A stream ID 01<br>0x2: Link A stream ID 10<br>0x3: Link A stream ID 11<br>0x4: Link B stream ID 00<br>0x5: Link B stream ID 01<br>0x6: Link B stream ID 10<br>0x7: Link B stream ID 11 |
| VIDEO_PIPE_SEL_Y | 2:0  | Selects the incoming stream ID to receive in Video Pipe Y | 0x0: Link A stream ID 00<br>0x1: Link A stream ID 01<br>0x2: Link A stream ID 10<br>0x3: Link A stream ID 11<br>0x4: Link B stream ID 00<br>0x5: Link B stream ID 01<br>0x6: Link B stream ID 10<br>0x7: Link B stream ID 11 |

**LINK\_SEL (0x162)**

|                    |          |          |          |          |                 |                    |                    |                    |
|--------------------|----------|----------|----------|----------|-----------------|--------------------|--------------------|--------------------|
| <b>BIT</b>         | <b>7</b> | <b>6</b> | <b>5</b> | <b>4</b> | <b>3</b>        | <b>2</b>           | <b>1</b>           | <b>0</b>           |
| <b>Field</b>       | –        | –        | –        | –        | SPI_LINK_SELECT | UART_2_LINK_SELECT | UART_1_LINK_SELECT | UART_0_LINK_SELECT |
| <b>Reset</b>       | –        | –        | –        | –        | 0b0             | 0b0                | 0b0                | 0b0                |
| <b>Access Type</b> | –        | –        | –        | –        | Write, Read     | Write, Read        | Write, Read        | Write, Read        |

| BITFIELD           | BITS | DESCRIPTION                                 | DECODE                     |
|--------------------|------|---|----------------------------|
| SPI_LINK_SELECT    | 3    | Selects link connection for SPI Port        | 0x0: Link A<br>0x1: Link B |
| UART_2_LINK_SELECT | 2    | UART Pass-Through 2 Link Connection Select  | 0x0: Link A<br>0x1: Link B |
| UART_1_LINK_SELECT | 1    | UART Pass-Through 1 Link Connection Select  | 0x0: Link A<br>0x1: Link B |
| UART_0_LINK_SELECT | 0    | Control Channel UART Link Connection Select | 0x0: Link A<br>0x1: Link B |

**SPI\_0 (0x170)**

|              |                 |          |                    |          |             |           |          |          |
|--------------|-----------------|----------|--------------------|----------|-------------|-----------|----------|----------|
| <b>BIT</b>   | <b>7</b>        | <b>6</b> | <b>5</b>           | <b>4</b> | <b>3</b>    | <b>2</b>  | <b>1</b> | <b>0</b> |
| <b>Field</b> | SPI_LOC_ID[1:0] |          | SPI_CC_TRG_ID[1:0] |          | SPI_IGNR_ID | SPI_CC_EN | MST_SLVN | SPI_EN   |
| <b>Reset</b> | 0b00            |          | 0b00               |          | 0b1         | 0b0       | 0b0      | 0b0      |

|                    |             |             |             |             |             |             |
|--------------------|-------------|-------------|-------------|-------------|-------------|-------------|
| <b>Access Type</b> | Write, Read | Write, Read | Write, Read | Write, Read | Write, Read | Write, Read |
|--------------------|-------------|-------------|-------------|-------------|-------------|-------------|

| BITFIELD      | BITS | DESCRIPTION  | DECODE   |
|---------------|------|--|--|
| SPI_LOC_ID    | 7:6  | Program to local ID if filtering packets based on header ID.                 | 0b00: ID = 0<br>0b01: ID = 1<br>0b10: ID = 2<br>0b11: ID = 3                     |
| SPI_CC_TRG_ID | 5:4  | ID for GMSL2 header in SPI control-channel bridge mode                       | 0b00: ID = 0<br>0b01: ID = 1<br>0b10: ID = 2<br>0b11: ID = 3                     |
| SPI_IGNR_ID   | 3    | Selects if SPI should use or ignore header ID to decide on packet acceptance | 0b0: Accept only packets with proper ID<br>0b1: Ignore ID and accept all packets |
| SPI_CC_EN     | 2    | Enable control-channel SPI bridge function                                   | 0b0: SPI bridge disabled<br>0b1: SPI bridge enabled                              |
| MST_SLVN      | 1    | Selects if SPI is main or subordinate  | 0b0: SPI subordinate<br>0b1: SPI main  |
| SPI_EN        | 0    | Enable SPI channel   | 0b0: SPI channel disabled<br>0b1: SPI channel enabled                            |

**SPI 1 (0x171)**

| BIT                | 7              | 6 | 5 | 4 | 3 | 2 | 1                  | 0 |
|--------------------|----------------|---|---|---|---|---|--------------------|---|
| <b>Field</b>       | SPI_LOC_N[5:0] |   |   |   |   |   | SPI_BASE_Prio[1:0] |   |
| <b>Reset</b>       | 0b000111       |   |   |   |   |   | 0b01               |   |
| <b>Access Type</b> | Write, Read    |   |   |   |   |   | Write, Read        |   |

| BITFIELD      | BITS | DESCRIPTION  | DECODE   |
|---------------|------|--|--|
| SPI_LOC_N     | 7:2  | Sets the packet size ((2N + 1) bytes) for GMSL2 SPI packets.<br>If this is programmed to a value more than 7, ARQ of the SPI channel must be disabled. | 0b000000: Packet size is 1 byte<br>0b000001: Packet size is 3 bytes<br>...<br>0b111111: Packet size is 127 bytes |
| SPI_BASE_Prio | 1:0  | Starting GMSL2 request priority, advances by 1 (if room) if Tx buffer is over half-full.   |  |

**SPI 2 (0x172)**

| BIT                | 7                 | 6 | 5              | 4           | 3           | 2              | 1              | 0 |
|--------------------|-------------------|---|----------------|-------------|-------------|----------------|----------------|---|
| <b>Field</b>       | REQ_HOLD_OFF[2:0] |   | FULL_SCK_SETUP | SPI_MOD3_F  | SPI_MOD3    | SPIM_SS2_ACT_H | SPIM_SS1_ACT_H |   |
| <b>Reset</b>       | 0b000             |   | 0b0            | 0b0         | 0b0         | 0b1            | 0b1            |   |
| <b>Access Type</b> | Write, Read       |   | Write, Read    | Write, Read | Write, Read | Write, Read    | Write, Read    |   |

| BITFIELD       | BITS | DESCRIPTION  | DECODE  |
|----------------|------|--|---|
| REQ_HOLD_OFF   | 7:5  | Hold off transmitting data across GMSL link until this number of extra bytes are received on SPI port.                       | 0b00: No extra bytes<br>0b01: 1 extra byte<br>0b10: 2 extra bytes<br>0b11: 3 extra bytes  |
| FULL_SCK_SETUP | 4    | Sample MISO after half- or full-SCK period.  | 0b0: MISO sampled after half-SCK period<br>0b1: MISO sampled after full-SCK period  |
| SPI_MOD3_F     | 3    | Allows the suppression of an extra SCK prior to SS deassertion when SPI mode 3 is selected.                                  | 0b0: Extra SCK present prior to SS deassertion when in SPI mode 3<br>0b1: Extra SCK suppressed prior to SS deassertion when in SPI mode 3   |
| SPI_MOD3       | 2    | Selects SPI mode 0 or 3.<br><br>In both modes, data is sampled on the rising clock edge and shifted out on the falling edge. | 0b0: SPI mode 0. Clock polarity and phase are 0. Subordinate select asserts when clock is low.<br>0b1: SPI mode 3. Clock polarity and phase are 1. Subordinate select asserts when clock is high. |
| SPIM_SS2_ACT_H | 1    | Sets the polarity for SS2 when the SPI is a main.  | 0b0: Subordinate select 2 is active low<br>0b1: Subordinate select 2 is active high   |
| SPIM_SS1_ACT_H | 0    | Sets the polarity for SS1 when the SPI is a main.  | 0b0: Subordinate select 1 is active low<br>0b1: Subordinate select 1 is active high   |

**SPI 3 (0x173)**

| BIT         | 7                     | 6 | 5 | 4 | 3 | 2 | 1 | 0 |
|-------------|-----------------------|---|---|---|---|---|---|---|
| Field       | SPIM_SS_DLY_CLKS[7:0] |   |   |   |   |   |   |   |
| Reset       | 0x00                  |   |   |   |   |   |   |   |
| Access Type | Write, Read           |   |   |   |   |   |   |   |

| BITFIELD         | BITS | DESCRIPTION   | DECODE                       |
|------------------|------|---|------------------------------|
| SPIM_SS_DLY_CLKS | 7:0  | Number of 300MHz clocks to delay between:<br><ul style="list-style-type: none"> <li>• Assertion of SS and start of SCK pulses</li> <li>• End of SCK pulses and deassertion of SS</li> <li>• Deassertion of SS and reassertion of SS (if necessary)</li> </ul> | 0xXX: Number of clock delays |

**SPI 4 (0x174)**

| BIT         | 7                     | 6 | 5 | 4 | 3 | 2 | 1 | 0 |
|-------------|-----------------------|---|---|---|---|---|---|---|
| Field       | SPIM_SCK_LO_CLKS[7:0] |   |   |   |   |   |   |   |
| Reset       | 0x00                  |   |   |   |   |   |   |   |
| Access Type | Write, Read           |   |   |   |   |   |   |   |

| BITFIELD         | BITS | DESCRIPTION                               | DECODE                                  |
|------------------|------|---|---|
| SPIM_SCK_LO_CLKS | 7:0  | Number of 300MHz clocks for SCK low time. | 0xXX: Number of clocks for SCK low time |

**SPI 5 (0x175)**

| BIT         | 7                     | 6 | 5 | 4 | 3 | 2 | 1 | 0 |
|-------------|-----------------------|---|---|---|---|---|---|---|
| Field       | SPIM_SCK_HI_CLKS[7:0] |   |   |   |   |   |   |   |
| Reset       | 0x00                  |   |   |   |   |   |   |   |
| Access Type | Write, Read           |   |   |   |   |   |   |   |

| BITFIELD         | BITS | DESCRIPTION                                | DECODE                                   |
|------------------|------|--|--|
| SPIM_SCK_HI_CLKS | 7:0  | Number of 300MHz clocks for SCK high time. | 0xXX: Number of clocks for SCK high time |

**SPI 6 (0x176)**

| BIT         | 7 | 6 | 5         | 4           | 3           | 2           | 1           | 0           |
|-------------|---|---|-----------|-------------|-------------|-------------|-------------|-------------|
| Field       | – | – | BNE       | SPIS_RWN    | SS_IO_EN_2  | SS_IO_EN_1  | BNE_IO_EN   | RWN_IO_EN   |
| Reset       | – | – | 0b0       | 0b0         | 0b0         | 0b0         | 0b0         | 0b0         |
| Access Type | – | – | Read Only | Write, Read | Write, Read | Write, Read | Write, Read | Write, Read |

| BITFIELD   | BITS | DESCRIPTION  | DECODE   |
|------------|------|--|--|
| BNE        | 5    | Alternate GPU status register to use for BNE status if GPIO is not available               | 0b0: Buffer empty<br>0b1: Buffer not empty                                     |
| SPIS_RWN   | 4    | Alternate GPU control register to use for read and write control if GPIO is not available. | 0b0: Write<br>0b1: Read  |
| SS_IO_EN_2 | 3    | Enable GPIO for use as Subordinate Select 2 output.  | 0b0: GPIO not used for SPI SS2 function<br>0b1: GPIO used for SPI SS2 function |
| SS_IO_EN_1 | 2    | Enable GPIO for use as Subordinate Select 1 output.  | 0b0: GPIO not used for SPI SS1 function<br>0b1: GPIO used for SPI SS1 function |
| BNE_IO_EN  | 1    | Enable GPIO for use as BNE output for SPI data available status.                           | 0b0: GPIO not used for SPI BNE function<br>0b1: GPIO used for SPI BNE function |
| RWN_IO_EN  | 0    | Enable GPIO for use as RO input for control of SPI data movement.                          | 0b0: GPIO not used for SPI RO function<br>0b1: GPIO used for SPI RO function   |

**SPI 7 (0x177)**

| BIT | 7 | 6 | 5 | 4 | 3 | 2 | 1 | 0 |
|-----|---|---|---|---|---|---|---|---|
|-----|---|---|---|---|---|---|---|---|

|                    |                 |                 |             |                    |
|--------------------|-----------------|-----------------|-------------|--------------------|
| <b>Field</b>       | SPI_RX_OVRFLW   | SPI_TX_OVRFLW   | RO_ALT      | SPIS_BYTE_CNT[4:0] |
| <b>Reset</b>       | 0b0             | 0b0             | 0b0         | 0b00000            |
| <b>Access Type</b> | Read Clears All | Read Clears All | Write, Read | Read Only          |

| BITFIELD      | BITS | DESCRIPTION   | DECODE  |
|---------------|------|---|---|
| SPI_RX_OVRFLW | 7    | SPI Rx buffer overflow flag                                   | 0b0: No SPI Rx buffer overflow<br>0b1: SPI Rx buffer overflow |
| SPI_TX_OVRFLW | 6    | SPI Tx buffer overflow flag                                   | 0b0: No SPI Tx buffer overflow<br>0b1: SPI Tx buffer overflow |
| RO_ALT        | 5    | When set to 1, use the alternative pin for RO                 |   |
| SPIS_BYTE_CNT | 4:0  | Number of SPI data bytes available for reading from Rx buffer | 0bXXXXX: Number of bytes available                            |

**SPI 8 (0x178)**

|                    |                      |          |          |          |          |          |          |          |
|--------------------|----------------------|----------|----------|----------|----------|----------|----------|----------|
| <b>BIT</b>         | <b>7</b>             | <b>6</b> | <b>5</b> | <b>4</b> | <b>3</b> | <b>2</b> | <b>1</b> | <b>0</b> |
| <b>Field</b>       | REQ_HOLD_OFF_TO[7:0] |          |          |          |          |          |          |          |
| <b>Reset</b>       | 0x00                 |          |          |          |          |          |          |          |
| <b>Access Type</b> | Write, Read          |          |          |          |          |          |          |          |

| BITFIELD        | BITS | DESCRIPTION  | DECODE  |
|-----------------|------|--|---|
| REQ_HOLD_OFF_TO | 7:0  | Timeout delay (in 100nS increments) for GMSL2 request hold off (0 is disable). | 0xXX: Number of 100nS delay increments for GMSL2 request hold off |

**WM 0 (0x190)**

|                    |             |              |          |          |             |          |          |             |
|--------------------|-------------|--------------|----------|----------|-------------|----------|----------|-------------|
| <b>BIT</b>         | <b>7</b>    | <b>6</b>     | <b>5</b> | <b>4</b> | <b>3</b>    | <b>2</b> | <b>1</b> | <b>0</b>    |
| <b>Field</b>       | WM_LEN      | WM_MODE[2:0] |          |          | WM_DET[1:0] |          | –        | WM_EN       |
| <b>Reset</b>       | 0b0         | 0b000        |          |          | 0b00        |          | –        | 0b0         |
| <b>Access Type</b> | Write, Read | Write, Read  |          |          | Write, Read |          | –        | Write, Read |

| BITFIELD | BITS | DESCRIPTION      | DECODE  |
|----------|------|------------------|---|
| WM_LEN   | 7    | Watermark Length | 0b0: 32-bit<br>0b1: 64-bit  |
| WM_MODE  | 6:4  | Watermark Mode   | 0b000: Default generator mode - cycle through all four watermarks in video stream<br>0b001: Error generator mode - cycle through only two watermarks to replicate a frozen frame error condition<br>0b010: Reserved |

| BITFIELD | BITS | DESCRIPTION                    | DECODE   |
|----------|------|--------------------------------|--|
|          |      |                                | 0b011: Reserved<br>0b100: Reserved<br>0b101: Reserved<br>0b110: Reserved<br>0b111: Reserved  |
| WM_DET   | 3:2  | Watermark Detection/Generation | 0b00: Insert watermark in video stream<br>0b01: Detect watermark and remove from outgoing video stream<br>0b10: Reserved<br>0b11: Reserved |
| WM_EN    | 0    | Watermark Enable               | 0b0: Watermarking disabled<br>0b1: Watermarking enabled  |

**WM 2 (0x192)**

| BIT         | 7 | 6 | 5 | 4 | 3           | 2           | 1              | 0 |
|-------------|---|---|---|---|-------------|-------------|----------------|---|
| Field       | – | – | – | – | HsyncPol    | VsyncPol    | WM_NPFILT[1:0] |   |
| Reset       | – | – | – | – | 0b0         | 0b0         | 0b00           |   |
| Access Type | – | – | – | – | Write, Read | Write, Read | Write, Read    |   |

| BITFIELD  | BITS | DESCRIPTION                      | DECODE                           |
|-----------|------|----------------------------------|----------------------------------|
| HsyncPol  | 3    | HS Polarity                      | 0b0: Noninverting<br>0x1: Invert |
| VsyncPol  | 2    | VS Polarity                      | 0b0: Noninverting<br>0x1: Invert |
| WM_NPFILT | 1:0  | Phase accumulator terminal count | 0xXX: Counter value              |

**WM 4 (0x194)**

| BIT         | 7 | 6 | 5 | 4 | 3 | 2 | 1                | 0 |
|-------------|---|---|---|---|---|---|------------------|---|
| Field       | – | – | – | – | – | – | WM_MASKMODE[1:0] |   |
| Reset       | – | – | – | – | – | – | 0b00             |   |
| Access Type | – | – | – | – | – | – | Write, Read      |   |

| BITFIELD    | BITS | DESCRIPTION                                       | DECODE   |
|-------------|------|---|--|
| WM_MASKMODE | 1:0  | Sets watermark video mask behavior for the device | 0b00: Mask video if WM is detected<br>0b01: Mask video if WM is detected, blank if error is detected<br>0b10: Reserved<br>b011: Reserved |

**WM 5 (0x195)**

| BIT         | 7 | 6 | 5 | 4 | 3 | 2 | 1         | 0         |
|-------------|---|---|---|---|---|---|-----------|-----------|
| Field       | – | – | – | – | – | – | WM_DETOUT | WM_ERROR  |
| Reset       | – | – | – | – | – | – | 0b0       | 0b0       |
| Access Type | – | – | – | – | – | – | Read Only | Read Only |

| BITFIELD  | BITS | DESCRIPTION                                | DECODE  |
|-----------|------|--|---|
| WM_DETOUT | 1    | Live value of frame-based detection output | 0b0: Watermark not detected<br>0b1: Watermark detected  |
| WM_ERROR  | 0    | Live value of active-high watermark error  | 0b0: No watermark error<br>0b1: Watermark error active, bit automatically clears when error clears. |

**WM 6 (0x196)**

| BIT         | 7             | 6 | 5 | 4 | 3 | 2 | 1 | 0 |
|-------------|---------------|---|---|---|---|---|---|---|
| Field       | WM_TIMER[7:0] |   |   |   |   |   |   |   |
| Reset       | 0x00          |   |   |   |   |   |   |   |
| Access Type | Write, Read   |   |   |   |   |   |   |   |

| BITFIELD | BITS | DESCRIPTION  | DECODE                       |
|----------|------|--|------------------------------|
| WM_TIMER | 7:0  | Time (in 2ms steps) the frozen-frame condition must be observed before an error is generated.<br><br>0 = No filter | 0xXX: Number of milliseconds |

**WM WREN 0 (0x1AE)**

| BIT         | 7              | 6 | 5 | 4 | 3 | 2 | 1 | 0 |
|-------------|----------------|---|---|---|---|---|---|---|
| Field       | WM_WREN_L[7:0] |   |   |   |   |   |   |   |
| Reset       | 0x00           |   |   |   |   |   |   |   |
| Access Type | Write, Read    |   |   |   |   |   |   |   |

| BITFIELD  | BITS | DESCRIPTION   | DECODE   |
|-----------|------|---|--|
| WM_WREN_L | 7:0  | Works in conjunction with WM_WREN_H to enable writing to watermark registers. | 0xBA: Enables writing to WM registers<br>Others: WM registers remain read-only |

| BITFIELD | BITS | DESCRIPTION   | DECODE |
|----------|------|---|--------|
|          |      | Writing is enabled to watermark registers when 0xBA is written to WM_WREN_L and 0xDC is written to WM_WREN_H registers. Otherwise, watermark registers are read-only. |        |

**WM\_WREN 1 (0x1AF)**

| BIT         | 7              | 6 | 5 | 4 | 3 | 2 | 1 | 0 |
|-------------|----------------|---|---|---|---|---|---|---|
| Field       | WM_WREN_H[7:0] |   |   |   |   |   |   |   |
| Reset       | 0x00           |   |   |   |   |   |   |   |
| Access Type | Write, Read    |   |   |   |   |   |   |   |

| BITFIELD  | BITS | DESCRIPTION  | DECODE   |
|-----------|------|--|--|
| WM_WREN_H | 7:0  | Works in conjunction with WM_WREN_L to enable writing to watermark registers.<br><br>Writing is enabled to watermark registers when 0xBA is written to WM_WREN_L and 0xDC is written to WM_WREN_H registers. Otherwise, watermark registers are read-only. | 0xDC: Enables writing to WM registers<br>Others: WM registers remain read-only |

**CROSS 0 (0x1E0, 0x200)**

| BIT         | 7 | 6           | 5           | 4           | 3 | 2 | 1 | 0 |
|-------------|---|-------------|-------------|-------------|---|---|---|---|
| Field       | – | CROSS0_I    | CROSS0_F    | CROSS0[4:0] |   |   |   |   |
| Reset       | – | 0b0         | 0b0         | 0b00000     |   |   |   |   |
| Access Type | – | Write, Read | Write, Read | Write, Read |   |   |   |   |

| BITFIELD | BITS | DESCRIPTION  | DECODE  |
|----------|------|--|---|
| CROSS0_I | 6    | Invert outgoing bit 0  | 0b0: Do not invert bit<br>0b1: Invert bit               |
| CROSS0_F | 5    | Force outgoing bit 0 to 0. Applied before inversion so that if inversion is also set, the outgoing bit is forced to 1. | 0b0: Do not force bit to zero<br>0b1: Force bit to zero |
| CROSS0   | 4:0  | Maps incoming bit position set by this field to the outgoing bit position 0  | 0bXXXXX: Incoming bit position                          |

**CROSS 1 (0x1E1, 0x201)**

| BIT         | 7 | 6           | 5           | 4           | 3 | 2 | 1 | 0 |
|-------------|---|-------------|-------------|-------------|---|---|---|---|
| Field       | – | CROSS1_I    | CROSS1_F    | CROSS1[4:0] |   |   |   |   |
| Reset       | – | 0b0         | 0b0         | 0b00001     |   |   |   |   |
| Access Type | – | Write, Read | Write, Read | Write, Read |   |   |   |   |

| BITFIELD | BITS | DESCRIPTION  | DECODE  |
|----------|------|--|---|
| CROSS1_I | 6    | Invert outgoing bit 1  | 0b0: Do not invert bit<br>0b1: Invert bit               |
| CROSS1_F | 5    | Force outgoing bit 1 to 0. Applied before inversion so that if inversion is also set, the outgoing bit is forced to 1. | 0b0: Do not force bit to zero<br>0b1: Force bit to zero |
| CROSS1   | 4:0  | Maps incoming bit position set by this field to the outgoing bit position 1  | 0bXXXXX: Incoming bit position                          |

**CROSS 2 (0x1E2, 0x202)**

| BIT         | 7 | 6           | 5           | 4           | 3 | 2 | 1 | 0 |
|-------------|---|-------------|-------------|-------------|---|---|---|---|
| Field       | – | CROSS2_I    | CROSS2_F    | CROSS2[4:0] |   |   |   |   |
| Reset       | – | 0b0         | 0b0         | 0b00010     |   |   |   |   |
| Access Type | – | Write, Read | Write, Read | Write, Read |   |   |   |   |

| BITFIELD | BITS | DESCRIPTION  | DECODE  |
|----------|------|--|---|
| CROSS2_I | 6    | Invert outgoing bit 2  | 0b0: Do not invert bit<br>0b1: Invert bit               |
| CROSS2_F | 5    | Force outgoing bit 2 to 0. Applied before inversion so that if inversion is also set, the outgoing bit is forced to 1. | 0b0: Do not force bit to zero<br>0b1: Force bit to zero |
| CROSS2   | 4:0  | Maps incoming bit position set by this field to the outgoing bit position 2  | 0bXXXXX: Incoming bit position                          |

**CROSS 3 (0x1E3, 0x203)**

| BIT         | 7 | 6           | 5           | 4           | 3 | 2 | 1 | 0 |
|-------------|---|-------------|-------------|-------------|---|---|---|---|
| Field       | – | CROSS3_I    | CROSS3_F    | CROSS3[4:0] |   |   |   |   |
| Reset       | – | 0b0         | 0b0         | 0b00011     |   |   |   |   |
| Access Type | – | Write, Read | Write, Read | Write, Read |   |   |   |   |

| BITFIELD | BITS | DESCRIPTION  | DECODE  |
|----------|------|--|---|
| CROSS3_I | 6    | Invert outgoing bit 3  | 0b0: Do not invert bit<br>0b1: Invert bit               |
| CROSS3_F | 5    | Force outgoing bit 3 to 0. Applied before inversion so that if inversion is also set, the outgoing bit is forced to 1. | 0b0: Do not force bit to zero<br>0b1: Force bit to zero |
| CROSS3   | 4:0  | Maps incoming bit position set by this field to the outgoing bit position 3  | 0bXXXXX: Incoming bit position                          |

**CROSS 4 (0x1E4, 0x204)**

| BIT         | 7 | 6           | 5           | 4           | 3 | 2 | 1 | 0 |
|-------------|---|-------------|-------------|-------------|---|---|---|---|
| Field       | – | CROSS4_I    | CROSS4_F    | CROSS4[4:0] |   |   |   |   |
| Reset       | – | 0b0         | 0b0         | 0b00100     |   |   |   |   |
| Access Type | – | Write, Read | Write, Read | Write, Read |   |   |   |   |

| BITFIELD | BITS | DESCRIPTION  | DECODE  |
|----------|------|--|---|
| CROSS4_I | 6    | Invert outgoing bit 4  | 0b0: Do not invert bit<br>0b1: Invert bit               |
| CROSS4_F | 5    | Force outgoing bit 4 to 0. Applied before inversion so that if inversion is also set, the outgoing bit is forced to 1. | 0b0: Do not force bit to zero<br>0b1: Force bit to zero |
| CROSS4   | 4:0  | Maps incoming bit position set by this field to the outgoing bit position 4  | 0bXXXXX: Incoming bit position                          |

**CROSS 5 (0x1E5, 0x205)**

| BIT         | 7 | 6           | 5           | 4           | 3 | 2 | 1 | 0 |
|-------------|---|-------------|-------------|-------------|---|---|---|---|
| Field       | – | CROSS5_I    | CROSS5_F    | CROSS5[4:0] |   |   |   |   |
| Reset       | – | 0b0         | 0b0         | 0b00101     |   |   |   |   |
| Access Type | – | Write, Read | Write, Read | Write, Read |   |   |   |   |

| BITFIELD | BITS | DESCRIPTION  | DECODE  |
|----------|------|--|---|
| CROSS5_I | 6    | Invert outgoing bit 5  | 0b0: Do not invert bit<br>0b1: Invert bit               |
| CROSS5_F | 5    | Force outgoing bit 5 to 0. Applied before inversion so that if inversion is also set, the outgoing bit is forced to 1. | 0b0: Do not force bit to zero<br>0b1: Force bit to zero |
| CROSS5   | 4:0  | Maps incoming bit position set by this field to the outgoing bit position 5  | 0bXXXXX: Incoming bit position                          |

**CROSS 6 (0x1E6, 0x206)**

| BIT         | 7 | 6           | 5           | 4           | 3 | 2 | 1 | 0 |
|-------------|---|-------------|-------------|-------------|---|---|---|---|
| Field       | – | CROSS6_I    | CROSS6_F    | CROSS6[4:0] |   |   |   |   |
| Reset       | – | 0b0         | 0b0         | 0b00110     |   |   |   |   |
| Access Type | – | Write, Read | Write, Read | Write, Read |   |   |   |   |

| BITFIELD | BITS | DESCRIPTION  | DECODE  |
|----------|------|--|---|
| CROSS6_I | 6    | Invert outgoing bit 6  | 0b0: Do not invert bit<br>0b1: Invert bit               |
| CROSS6_F | 5    | Force outgoing bit 6 to 0. Applied before inversion so that if inversion is also set, the outgoing bit is forced to 1. | 0b0: Do not force bit to zero<br>0b1: Force bit to zero |
| CROSS6   | 4:0  | Maps incoming bit position set by this field to the outgoing bit position 6  | 0bXXXXX: Incoming bit position                          |

**CROSS 7 (0x1E7, 0x207)**

| BIT         | 7 | 6           | 5           | 4           | 3 | 2 | 1 | 0 |
|-------------|---|-------------|-------------|-------------|---|---|---|---|
| Field       | – | CROSS7_I    | CROSS7_F    | CROSS7[4:0] |   |   |   |   |
| Reset       | – | 0b0         | 0b0         | 0b00111     |   |   |   |   |
| Access Type | – | Write, Read | Write, Read | Write, Read |   |   |   |   |

| BITFIELD | BITS | DESCRIPTION  | DECODE  |
|----------|------|--|---|
| CROSS7_I | 6    | Invert outgoing bit 7  | 0b0: Do not invert bit<br>0b1: Invert bit               |
| CROSS7_F | 5    | Force outgoing bit 7 to 0. Applied before inversion so that if inversion is also set, the outgoing bit is forced to 1. | 0b0: Do not force bit to zero<br>0b1: Force bit to zero |
| CROSS7   | 4:0  | Maps incoming bit position set by this field to the outgoing bit position 7  | 0bXXXXX: Incoming bit position                          |

**CROSS 8 (0x1E8, 0x208)**

| BIT         | 7 | 6           | 5           | 4           | 3 | 2 | 1 | 0 |
|-------------|---|-------------|-------------|-------------|---|---|---|---|
| Field       | – | CROSS8_I    | CROSS8_F    | CROSS8[4:0] |   |   |   |   |
| Reset       | – | 0b0         | 0b0         | 0b01000     |   |   |   |   |
| Access Type | – | Write, Read | Write, Read | Write, Read |   |   |   |   |

| BITFIELD | BITS | DESCRIPTION  | DECODE  |
|----------|------|--|---|
| CROSS8_I | 6    | Invert outgoing bit 8  | 0b0: Do not invert bit<br>0b1: Invert bit               |
| CROSS8_F | 5    | Force outgoing bit 8 to 0. Applied before inversion so that if inversion is also set, the outgoing bit is forced to 1. | 0b0: Do not force bit to zero<br>0b1: Force bit to zero |
| CROSS8   | 4:0  | Maps incoming bit position set by this field to the outgoing bit position 8  | 0bXXXXX: Incoming bit position                          |

**CROSS 9 (0x1E9, 0x209)**

| BIT         | 7 | 6           | 5           | 4           | 3 | 2 | 1 | 0 |
|-------------|---|-------------|-------------|-------------|---|---|---|---|
| Field       | – | CROSS9_I    | CROSS9_F    | CROSS9[4:0] |   |   |   |   |
| Reset       | – | 0b0         | 0b0         | 0b01001     |   |   |   |   |
| Access Type | – | Write, Read | Write, Read | Write, Read |   |   |   |   |

| BITFIELD | BITS | DESCRIPTION  | DECODE  |
|----------|------|--|---|
| CROSS9_I | 6    | Invert outgoing bit 9  | 0b0: Do not invert bit<br>0b1: Invert bit               |
| CROSS9_F | 5    | Force outgoing bit 9 to 0. Applied before inversion so that if inversion is also set, the outgoing bit is forced to 1. | 0b0: Do not force bit to zero<br>0b1: Force bit to zero |
| CROSS9   | 4:0  | Maps incoming bit position set by this field to the outgoing bit position 9  | 0bXXXXX: Incoming bit position                          |

**CROSS 10 (0x1EA, 0x20A)**

| BIT         | 7 | 6           | 5           | 4            | 3 | 2 | 1 | 0 |
|-------------|---|-------------|-------------|--------------|---|---|---|---|
| Field       | – | CROSS10_I   | CROSS10_F   | CROSS10[4:0] |   |   |   |   |
| Reset       | – | 0b0         | 0b0         | 0b01010      |   |   |   |   |
| Access Type | – | Write, Read | Write, Read | Write, Read  |   |   |   |   |

| BITFIELD  | BITS | DESCRIPTION   | DECODE  |
|-----------|------|---|---|
| CROSS10_I | 6    | Invert outgoing bit 10  | 0b0: Do not invert bit<br>0b1: Invert bit               |
| CROSS10_F | 5    | Force outgoing bit 10 to 0. Applied before inversion so that if inversion is also set, the outgoing bit is forced to 1. | 0b0: Do not force bit to zero<br>0b1: Force bit to zero |
| CROSS10   | 4:0  | Maps incoming bit position set by this field to the outgoing bit position 10  | 0bXXXXX: Incoming bit position                          |

**CROSS 11 (0x1EB, 0x20B)**

| BIT         | 7 | 6           | 5           | 4            | 3 | 2 | 1 | 0 |
|-------------|---|-------------|-------------|--------------|---|---|---|---|
| Field       | – | CROSS11_I   | CROSS11_F   | CROSS11[4:0] |   |   |   |   |
| Reset       | – | 0b0         | 0b0         | 0b01011      |   |   |   |   |
| Access Type | – | Write, Read | Write, Read | Write, Read  |   |   |   |   |

| BITFIELD  | BITS | DESCRIPTION   | DECODE  |
|-----------|------|---|---|
| CROSS11_I | 6    | Invert outgoing bit 11  | 0b0: Do not invert bit<br>0b1: Invert bit               |
| CROSS11_F | 5    | Force outgoing bit 11 to 0. Applied before inversion so that if inversion is also set, the outgoing bit is forced to 1. | 0b0: Do not force bit to zero<br>0b1: Force bit to zero |
| CROSS11   | 4:0  | Maps incoming bit position set by this field to the outgoing bit position 11  | 0bXXXXX: Incoming bit position                          |

**CROSS 12 (0x1EC, 0x20C)**

| BIT         | 7 | 6           | 5           | 4            | 3 | 2 | 1 | 0 |
|-------------|---|-------------|-------------|--------------|---|---|---|---|
| Field       | – | CROSS12_I   | CROSS12_F   | CROSS12[4:0] |   |   |   |   |
| Reset       | – | 0b0         | 0b0         | 0b01100      |   |   |   |   |
| Access Type | – | Write, Read | Write, Read | Write, Read  |   |   |   |   |

| BITFIELD  | BITS | DESCRIPTION   | DECODE  |
|-----------|------|---|---|
| CROSS12_I | 6    | Invert outgoing bit 12  | 0b0: Do not invert bit<br>0b1: Invert bit               |
| CROSS12_F | 5    | Force outgoing bit 12 to 0. Applied before inversion so that if inversion is also set, the outgoing bit is forced to 1. | 0b0: Do not force bit to zero<br>0b1: Force bit to zero |
| CROSS12   | 4:0  | Maps incoming bit position set by this field to the outgoing bit position 12  | 0bXXXXX: Incoming bit position                          |

**CROSS 13 (0x1ED, 0x20D)**

| BIT         | 7 | 6           | 5           | 4            | 3 | 2 | 1 | 0 |
|-------------|---|-------------|-------------|--------------|---|---|---|---|
| Field       | – | CROSS13_I   | CROSS13_F   | CROSS13[4:0] |   |   |   |   |
| Reset       | – | 0b0         | 0b0         | 0b01101      |   |   |   |   |
| Access Type | – | Write, Read | Write, Read | Write, Read  |   |   |   |   |

| BITFIELD  | BITS | DESCRIPTION   | DECODE  |
|-----------|------|---|---|
| CROSS13_I | 6    | Invert outgoing bit 13  | 0b0: Do not invert bit<br>0b1: Invert bit               |
| CROSS13_F | 5    | Force outgoing bit 13 to 0. Applied before inversion so that if inversion is also set, the outgoing bit is forced to 1. | 0b0: Do not force bit to zero<br>0b1: Force bit to zero |
| CROSS13   | 4:0  | Maps incoming bit position set by this field to the outgoing bit position 13  | 0bXXXXX: Incoming bit position                          |

**CROSS 14 (0x1EE, 0x20E)**

| BIT         | 7 | 6           | 5           | 4            | 3 | 2 | 1 | 0 |
|-------------|---|-------------|-------------|--------------|---|---|---|---|
| Field       | – | CROSS14_I   | CROSS14_F   | CROSS14[4:0] |   |   |   |   |
| Reset       | – | 0b0         | 0b0         | 0b01110      |   |   |   |   |
| Access Type | – | Write, Read | Write, Read | Write, Read  |   |   |   |   |

| BITFIELD  | BITS | DESCRIPTION   | DECODE  |
|-----------|------|---|---|
| CROSS14_I | 6    | Invert outgoing bit 14  | 0b0: Do not invert bit<br>0b1: Invert bit               |
| CROSS14_F | 5    | Force outgoing bit 14 to 0. Applied before inversion so that if inversion is also set, the outgoing bit is forced to 1. | 0b0: Do not force bit to zero<br>0b1: Force bit to zero |
| CROSS14   | 4:0  | Maps incoming bit position set by this field to the outgoing bit position 14  | 0bXXXXX: Incoming bit position                          |

**CROSS 15 (0x1EF, 0x20F)**

| BIT         | 7 | 6           | 5           | 4            | 3 | 2 | 1 | 0 |
|-------------|---|-------------|-------------|--------------|---|---|---|---|
| Field       | – | CROSS15_I   | CROSS15_F   | CROSS15[4:0] |   |   |   |   |
| Reset       | – | 0b0         | 0b0         | 0b01111      |   |   |   |   |
| Access Type | – | Write, Read | Write, Read | Write, Read  |   |   |   |   |

| BITFIELD  | BITS | DESCRIPTION   | DECODE  |
|-----------|------|---|---|
| CROSS15_I | 6    | Invert outgoing bit 15  | 0b0: Do not invert bit<br>0b1: Invert bit               |
| CROSS15_F | 5    | Force outgoing bit 15 to 0. Applied before inversion so that if inversion is also set, the outgoing bit is forced to 1. | 0b0: Do not force bit to zero<br>0b1: Force bit to zero |
| CROSS15   | 4:0  | Maps incoming bit position set by this field to the outgoing bit position 15  | 0bXXXXX: Incoming bit position                          |

**CROSS 16 (0x1F0, 0x210)**

| BIT         | 7 | 6           | 5           | 4            | 3 | 2 | 1 | 0 |
|-------------|---|-------------|-------------|--------------|---|---|---|---|
| Field       | – | CROSS16_I   | CROSS16_F   | CROSS16[4:0] |   |   |   |   |
| Reset       | – | 0b0         | 0b0         | 0b10000      |   |   |   |   |
| Access Type | – | Write, Read | Write, Read | Write, Read  |   |   |   |   |

| BITFIELD  | BITS | DESCRIPTION   | DECODE  |
|-----------|------|---|---|
| CROSS16_I | 6    | Invert outgoing bit 16  | 0b0: Do not invert bit<br>0b1: Invert bit               |
| CROSS16_F | 5    | Force outgoing bit 16 to 0. Applied before inversion so that if inversion is also set, the outgoing bit is forced to 1. | 0b0: Do not force bit to zero<br>0b1: Force bit to zero |
| CROSS16   | 4:0  | Maps incoming bit position set by this field to the outgoing bit position 16  | 0bXXXXX: Incoming bit position                          |

**CROSS 17 (0x1F1, 0x211)**

| BIT         | 7 | 6           | 5           | 4            | 3 | 2 | 1 | 0 |
|-------------|---|-------------|-------------|--------------|---|---|---|---|
| Field       | – | CROSS17_I   | CROSS17_F   | CROSS17[4:0] |   |   |   |   |
| Reset       | – | 0b0         | 0b0         | 0b10001      |   |   |   |   |
| Access Type | – | Write, Read | Write, Read | Write, Read  |   |   |   |   |

| BITFIELD  | BITS | DESCRIPTION   | DECODE  |
|-----------|------|---|---|
| CROSS17_I | 6    | Invert outgoing bit 17  | 0b0: Do not invert bit<br>0b1: Invert bit               |
| CROSS17_F | 5    | Force outgoing bit 17 to 0. Applied before inversion so that if inversion is also set, the outgoing bit is forced to 1. | 0b0: Do not force bit to zero<br>0b1: Force bit to zero |
| CROSS17   | 4:0  | Maps incoming bit position set by this field to the outgoing bit position 17  | 0bXXXXX: Incoming bit position                          |

**CROSS 18 (0x1F2, 0x212)**

| BIT         | 7 | 6           | 5           | 4            | 3 | 2 | 1 | 0 |
|-------------|---|-------------|-------------|--------------|---|---|---|---|
| Field       | – | CROSS18_I   | CROSS18_F   | CROSS18[4:0] |   |   |   |   |
| Reset       | – | 0b0         | 0b0         | 0b10010      |   |   |   |   |
| Access Type | – | Write, Read | Write, Read | Write, Read  |   |   |   |   |

| BITFIELD  | BITS | DESCRIPTION   | DECODE  |
|-----------|------|---|---|
| CROSS18_I | 6    | Invert outgoing bit 18  | 0b0: Do not invert bit<br>0b1: Invert bit               |
| CROSS18_F | 5    | Force outgoing bit 18 to 0. Applied before inversion so that if inversion is also set, the outgoing bit is forced to 1. | 0b0: Do not force bit to zero<br>0b1: Force bit to zero |
| CROSS18   | 4:0  | Maps incoming bit position set by this field to the outgoing bit position 18  | 0bXXXXX: Incoming bit position                          |

**CROSS 19 (0x1F3, 0x213)**

| BIT         | 7 | 6           | 5           | 4            | 3 | 2 | 1 | 0 |
|-------------|---|-------------|-------------|--------------|---|---|---|---|
| Field       | – | CROSS19_I   | CROSS19_F   | CROSS19[4:0] |   |   |   |   |
| Reset       | – | 0b0         | 0b0         | 0b10011      |   |   |   |   |
| Access Type | – | Write, Read | Write, Read | Write, Read  |   |   |   |   |

| BITFIELD  | BITS | DESCRIPTION   | DECODE  |
|-----------|------|---|---|
| CROSS19_I | 6    | Invert outgoing bit 19  | 0b0: Do not invert bit<br>0b1: Invert bit               |
| CROSS19_F | 5    | Force outgoing bit 19 to 0. Applied before inversion so that if inversion is also set, the outgoing bit is forced to 1. | 0b0: Do not force bit to zero<br>0b1: Force bit to zero |
| CROSS19   | 4:0  | Maps incoming bit position set by this field to the outgoing bit position 19  | 0bXXXXX: Incoming bit position                          |

**CROSS 20 (0x1F4, 0x214)**

| BIT         | 7 | 6           | 5           | 4            | 3 | 2 | 1 | 0 |
|-------------|---|-------------|-------------|--------------|---|---|---|---|
| Field       | – | CROSS20_I   | CROSS20_F   | CROSS20[4:0] |   |   |   |   |
| Reset       | – | 0b0         | 0b0         | 0b10100      |   |   |   |   |
| Access Type | – | Write, Read | Write, Read | Write, Read  |   |   |   |   |

| BITFIELD  | BITS | DESCRIPTION   | DECODE  |
|-----------|------|---|---|
| CROSS20_I | 6    | Invert outgoing bit 20  | 0b0: Do not invert bit<br>0b1: Invert bit               |
| CROSS20_F | 5    | Force outgoing bit 20 to 0. Applied before inversion so that if inversion is also set, the outgoing bit is forced to 1. | 0b0: Do not force bit to zero<br>0b1: Force bit to zero |
| CROSS20   | 4:0  | Maps incoming bit position set by this field to the outgoing bit position 20  | 0bXXXXX: Incoming bit position                          |

**CROSS 21 (0x1F5, 0x215)**

| BIT         | 7 | 6           | 5           | 4            | 3 | 2 | 1 | 0 |
|-------------|---|-------------|-------------|--------------|---|---|---|---|
| Field       | – | CROSS21_I   | CROSS21_F   | CROSS21[4:0] |   |   |   |   |
| Reset       | – | 0b0         | 0b0         | 0b10101      |   |   |   |   |
| Access Type | – | Write, Read | Write, Read | Write, Read  |   |   |   |   |

| BITFIELD  | BITS | DESCRIPTION   | DECODE  |
|-----------|------|---|---|
| CROSS21_I | 6    | Invert outgoing bit 21  | 0b0: Do not invert bit<br>0b1: Invert bit               |
| CROSS21_F | 5    | Force outgoing bit 21 to 0. Applied before inversion so that if inversion is also set, the outgoing bit is forced to 1. | 0b0: Do not force bit to zero<br>0b1: Force bit to zero |
| CROSS21   | 4:0  | Maps incoming bit position set by this field to the outgoing bit position 21  | 0bXXXXX: Incoming bit position                          |

**CROSS 22 (0x1F6, 0x216)**

| BIT         | 7 | 6           | 5           | 4            | 3 | 2 | 1 | 0 |
|-------------|---|-------------|-------------|--------------|---|---|---|---|
| Field       | – | CROSS22_I   | CROSS22_F   | CROSS22[4:0] |   |   |   |   |
| Reset       | – | 0b0         | 0b0         | 0b10110      |   |   |   |   |
| Access Type | – | Write, Read | Write, Read | Write, Read  |   |   |   |   |

| BITFIELD  | BITS | DESCRIPTION   | DECODE  |
|-----------|------|---|---|
| CROSS22_I | 6    | Invert outgoing bit 22  | 0b0: Do not invert bit<br>0b1: Invert bit               |
| CROSS22_F | 5    | Force outgoing bit 22 to 0. Applied before inversion so that if inversion is also set, the outgoing bit is forced to 1. | 0b0: Do not force bit to zero<br>0b1: Force bit to zero |
| CROSS22   | 4:0  | Maps incoming bit position set by this field to the outgoing bit position 22  | 0bXXXXX: Incoming bit position                          |

**CROSS 23 (0x1F7, 0x217)**

| BIT         | 7 | 6           | 5           | 4            | 3 | 2 | 1 | 0 |
|-------------|---|-------------|-------------|--------------|---|---|---|---|
| Field       | – | CROSS23_I   | CROSS23_F   | CROSS23[4:0] |   |   |   |   |
| Reset       | – | 0b0         | 0b0         | 0b10111      |   |   |   |   |
| Access Type | – | Write, Read | Write, Read | Write, Read  |   |   |   |   |

| BITFIELD  | BITS | DESCRIPTION   | DECODE  |
|-----------|------|---|---|
| CROSS23_I | 6    | Invert outgoing bit 23  | 0b0: Do not invert bit<br>0b1: Invert bit               |
| CROSS23_F | 5    | Force outgoing bit 23 to 0. Applied before inversion so that if inversion is also set, the outgoing bit is forced to 1. | 0b0: Do not force bit to zero<br>0b1: Force bit to zero |
| CROSS23   | 4:0  | Maps incoming bit position set by this field to the outgoing bit position 23  | 0bXXXXX: Incoming bit position                          |

**CROSS\_HS (0x1F8, 0x218)**

| BIT         | 7 | 6           | 5           | 4             | 3 | 2 | 1 | 0 |
|-------------|---|-------------|-------------|---------------|---|---|---|---|
| Field       | – | CROSS_HS_I  | CROSS_HS_F  | CROSS_HS[4:0] |   |   |   |   |
| Reset       | – | 0b0         | 0b0         | 0b11000       |   |   |   |   |
| Access Type | – | Write, Read | Write, Read | Write, Read   |   |   |   |   |

| BITFIELD   | BITS | DESCRIPTION  | DECODE  |
|------------|------|--|---|
| CROSS_HS_I | 6    | Invert CROSS_HS  | 0b0: Do not invert bit<br>0b1: Invert bit               |
| CROSS_HS_F | 5    | Force CROSS_HS to 0. Applied before inversion so that if inversion is also set, the outgoing bit is forced to 1. | 0b0: Do not force bit to zero<br>0b1: Force bit to zero |
| CROSS_HS   | 4:0  | Map selected internal signal to HS   | 0bXXXXX: Incoming bit position                          |

**CROSS\_VS (0x1F9, 0x219)**

| BIT         | 7 | 6           | 5           | 4             | 3 | 2 | 1 | 0 |
|-------------|---|-------------|-------------|---------------|---|---|---|---|
| Field       | – | CROSS_VS_I  | CROSS_VS_F  | CROSS_VS[4:0] |   |   |   |   |
| Reset       | – | 0b0         | 0b0         | 0b11001       |   |   |   |   |
| Access Type | – | Write, Read | Write, Read | Write, Read   |   |   |   |   |

| BITFIELD   | BITS | DESCRIPTION  | DECODE  |
|------------|------|--|---|
| CROSS_VS_I | 6    | Invert CROSS_VS  | 0b0: Do not invert bit<br>0b1: Invert bit               |
| CROSS_VS_F | 5    | Force CROSS_VS to 0. Applied before inversion so that if inversion is also set, the outgoing bit is forced to 1. | 0b0: Do not force bit to zero<br>0b1: Force bit to zero |
| CROSS_VS   | 4:0  | Map selected internal signal to VS   | 0bXXXXX: Incoming bit position                          |

**CROSS\_DE (0x1FA, 0x21A)**

| BIT         | 7 | 6           | 5           | 4             | 3 | 2 | 1 | 0 |
|-------------|---|-------------|-------------|---------------|---|---|---|---|
| Field       | – | CROSS_DE_I  | CROSS_DE_F  | CROSS_DE[4:0] |   |   |   |   |
| Reset       | – | 0b0         | 0b0         | 0b11010       |   |   |   |   |
| Access Type | – | Write, Read | Write, Read | Write, Read   |   |   |   |   |

| BITFIELD   | BITS | DESCRIPTION  | DECODE  |
|------------|------|--|---|
| CROSS_DE_I | 6    | Invert CROSS_DE  | 0b0: Do not invert bit<br>0b1: Invert bit               |
| CROSS_DE_F | 5    | Force CROSS_DE to 0. Applied before inversion so that if inversion is also set, the outgoing bit is forced to 1. | 0b0: Do not force bit to zero<br>0b1: Force bit to zero |
| CROSS_DE   | 4:0  | Map selected internal signal to DE   | 0bXXXXX: Incoming bit position                          |

**PRBS\_ERR (0x1FB, 0x21B)**

| BIT         | 7               | 6 | 5 | 4 | 3 | 2 | 1 | 0 |
|-------------|-----------------|---|---|---|---|---|---|---|
| Field       | VPRBS_ERR[7:0]  |   |   |   |   |   |   |   |
| Reset       | 0x00            |   |   |   |   |   |   |   |
| Access Type | Read Clears All |   |   |   |   |   |   |   |

| BITFIELD  | BITS | DESCRIPTION                              | DECODE  |
|-----------|------|--|---|
| VPRBS_ERR | 7:0  | Video PRBS error counter, clears on read | 0xXX: Number of video PRBS errors since last read |

**VPRBS (0x1FC, 0x21C)**

| BIT         | 7              | 6 | 5          | 4            | 3 | 2 | 1 | 0          |
|-------------|----------------|---|------------|--------------|---|---|---|------------|
| Field       | PATGEN_CLK_SRC | – | VPRBS_FAIL | VPRBS_CHK_EN | – | – | – | VIDEO_LOCK |
| Reset       | 0b1            | – | 0b0        | 0b0          | – | – | – | 0b0        |
| Access Type | Write, Read    | – | Read Only  | Write, Read  | – | – | – | Read Only  |

| BITFIELD       | BITS | DESCRIPTION  | DECODE                               |
|----------------|------|--|--------------------------------------|
| PATGEN_CLK_SRC | 7    | Pattern-generator clock source for video PRBS 7, 9, 24, checkerboard, and gradient patterns. Set bit 1 of the PIN_DRV_EN_0 register to 1 for this register to take effect. If it is set to 0, then | 0x0: 150MHz<br>0x1: 600MHz (default) |

| BITFIELD     | BITS | DESCRIPTION   | DECODE  |
|--------------|------|---|---|
|              |      | PIN_DRV_EN_0 bit 0 is used to select between a 75MHz clock (when 1) and 25MHz clock (when 0). |   |
| VPRBS_FAIL   | 5    | Video PRBS check pass/fail  | 0b0: Video PRBS check passed<br>0b1: Video check failed             |
| VPRBS_CHK_EN | 4    | Enable video PRBS checker   | 0b0: Video PRBS checker disabled<br>0b1: Video PRBS checker enabled |
| VIDEO_LOCK   | 0    | Video channel is locked and outputting valid video data                                       | 0b0: Video channel not locked<br>0b1: Video channel locked          |

**CROSS 27 (0x1FD, 0x21D)**

| BIT         | 7            | 6           | 5           | 4            | 3 | 2 | 1 | 0 |
|-------------|--------------|-------------|-------------|--------------|---|---|---|---|
| Field       | ALT_CROSSBAR | CROSS27_I   | CROSS27_F   | CROSS27[4:0] |   |   |   |   |
| Reset       | 0b0          | 0b0         | 0b0         | 0b11011      |   |   |   |   |
| Access Type | Write, Read  | Write, Read | Write, Read | Write, Read  |   |   |   |   |

| BITFIELD     | BITS | DESCRIPTION   | DECODE  |
|--------------|------|---|---|
| ALT_CROSSBAR | 7    | Selects whether to use the crossbar in the video pipe VRX block or the alternative crossbar in the GMSL1 datapath.      | 0x0: Use crossbar in VRX block<br>0x1: Use crossbar in GMSL1 datapath |
| CROSS27_I    | 6    | Invert outgoing bit 27  | 0b0: Do not invert bit<br>0b1: Invert bit                             |
| CROSS27_F    | 5    | Force outgoing bit 27 to 0. Applied before inversion so that if inversion is also set, the outgoing bit is forced to 1. | 0b0: Do not force bit to zero<br>0b1: Force bit to zero               |
| CROSS27      | 4:0  | Maps incoming bit position set by this field to the outgoing bit position 27  | 0bXXXXX: Incoming bit position  |

**CROSS 28 (0x1FE, 0x21E)**

| BIT         | 7 | 6           | 5           | 4            | 3 | 2 | 1 | 0 |
|-------------|---|-------------|-------------|--------------|---|---|---|---|
| Field       | – | CROSS28_I   | CROSS28_F   | CROSS28[4:0] |   |   |   |   |
| Reset       | – | 0b0         | 0b0         | 0b11100      |   |   |   |   |
| Access Type | – | Write, Read | Write, Read | Write, Read  |   |   |   |   |

| BITFIELD  | BITS | DESCRIPTION   | DECODE  |
|-----------|------|---|---|
| CROSS28_I | 6    | Invert outgoing bit 28  | 0b0: Do not invert bit<br>0b1: Invert bit               |
| CROSS28_F | 5    | Force outgoing bit 28 to 0. Applied before inversion so that if inversion is also set, the outgoing bit is forced to 1. | 0b0: Do not force bit to zero<br>0b1: Force bit to zero |

| BITFIELD | BITS | DESCRIPTION  | DECODE                         |
|----------|------|--|--------------------------------|
| CROSS28  | 4:0  | Maps incoming bit position set by this field to the outgoing bit position 28 | 0bXXXXX: Incoming bit position |

**CROSS 29 (0x1FF, 0x21F)**

| BIT         | 7 | 6           | 5           | 4            | 3 | 2 | 1 | 0 |
|-------------|---|-------------|-------------|--------------|---|---|---|---|
| Field       | – | CROSS29_I   | CROSS29_F   | CROSS29[4:0] |   |   |   |   |
| Reset       | – | 0b0         | 0b0         | 0b11101      |   |   |   |   |
| Access Type | – | Write, Read | Write, Read | Write, Read  |   |   |   |   |

| BITFIELD  | BITS | DESCRIPTION   | DECODE  |
|-----------|------|---|---|
| CROSS29_I | 6    | Invert outgoing bit 29  | 0b0: Do not invert bit<br>0b1: Invert bit               |
| CROSS29_F | 5    | Force outgoing bit 29 to 0. Applied before inversion so that if inversion is also set, the outgoing bit is forced to 1. | 0b0: Do not force bit to zero<br>0b1: Force bit to zero |
| CROSS29   | 4:0  | Maps incoming bit position set by this field to the outgoing bit position 29  | 0bXXXXX: Incoming bit position                          |

**PATGEN 0 (0x240)**

| BIT         | 7           | 6           | 5           | 4           | 3           | 2           | 1             | 0 |
|-------------|-------------|-------------|-------------|-------------|-------------|-------------|---------------|---|
| Field       | GEN_VS      | GEN_HS      | GEN_DE      | VS_INV      | HS_INV      | DE_INV      | VTG_MODE[1:0] |   |
| Reset       | 0b0         | 0b0         | 0b0         | 0b0         | 0b0         | 0b0         | 0b11          |   |
| Access Type | Write, Read | Write, Read | Write, Read | Write, Read | Write, Read | Write, Read | Write, Read   |   |

| BITFIELD | BITS | DESCRIPTION   | DECODE                                      |
|----------|------|---|---|
| GEN_VS   | 7    | Enable to generate VS output according to the timing definition programmed in the registers in the VRX_PATGEN block | 0b0: Do not generate VS<br>0b1: Generate VS |
| GEN_HS   | 6    | Enable to generate HS output according to the timing definition programmed in the registers in the VRX_PATGEN block | 0b0: Do not generate HS<br>0b1: Generate HS |
| GEN_DE   | 5    | Enable to generate DE output according to the timing definition programmed in the registers in the VRX_PATGEN block | 0b0: Do not generate DE<br>0b1: Generate DE |
| VS_INV   | 4    | Invert V <sub>SYNC</sub> output of video-timing generator   | 0b0: Do not invert VS<br>0b1: Invert VS     |
| HS_INV   | 3    | Invert H <sub>SYNC</sub> output of video-timing generator   | 0b0: Do not invert HS<br>0b1: Invert HS     |

| BITFIELD | BITS | DESCRIPTION   | DECODE   |
|----------|------|---|--|
| DE_INV   | 2    | Invert DE output of video-timing generator  | 0b0: Do not invert DE<br>0b1: Invert DE  |
| VTG_MODE | 1:0  | <p>Video-Timing Generation Mode</p> <p>VS input edge triggers the generation of continuous frames of VSO/HSO/DEO even if no more VS input edges.</p> <p>If the next VS input edge comes earlier or later than expected by VS period, the newly-generated frame is correct.</p> <p>The current VSO/HSO/DEO is cut or extended at the time of the rising edge of the newly-generated VSO/HSO/DEO.</p> | <p>0b00: VS-tracking mode<br/>VS input's period (VS_HIGH + VS_LOW) is tracked. After VS tracking is locked, any VS input edge (glitches) not in the expected PCLK cycle is ignored. VS tracking is locked with three consecutive matches and unlocked by three consecutive mismatches. When unlocked or at power-up, the next VS input edge is assumed to be the right VS edge.</p> <p>0b01: VS on trigger mode<br/>One VS input edge triggers the generation of one frame of VSO/HSO/DEO. If the next VS input edge comes earlier or later than expected by VS period, the newly-generated frame is correct. The current VSO/HSO/DEO is cut or extended at the time of the rising edge of the newly-generated VSO/HSO/DEO.</p> <p>0b10: Auto-repeat mode<br/>VS input edge triggers the generation of continuous frames of VSO/HSO/DEO even if no more VS input edges. If the next VS input edge comes earlier or later than expected by VS period, the newly-generated frame is correct. The current VSO/HSO/DEO is cut or extended at the time of the rising edge of the newly-generated VSO/HSO/DEO.</p> <p>0b11: Free-running mode<br/>Automatically starts generating the pattern relying on VS input.</p> |

**PATGEN 1 (0x241)**

| BIT         | 7           | 6 | 5                | 4 | 3 | 2 | 1 | 0           |
|-------------|-------------|---|------------------|---|---|---|---|-------------|
| Field       | GRAD_MODE   | – | PATGEN_MODE[1:0] |   | – | – | – | VS_TRIG     |
| Reset       | 0b0         | – | 0b00             |   | – | – | – | 0b0         |
| Access Type | Write, Read | – | Write, Read      |   | – | – | – | Write, Read |

| BITFIELD    | BITS | DESCRIPTION                     | DECODE   |
|-------------|------|---------------------------------|--|
| GRAD_MODE   | 7    | Gradient Pattern-Generator Mode | 0b0: Gradient mode increasing. Each gradient color starts from a value of 0x00 and increases to 0xFF.<br>0b1: Gradient mode decreasing. Each gradient color starts from a value of 0xFF and decreases to 0x00. |
| PATGEN_MODE | 5:4  | Pattern-Generator Mode          | 0b00: Pattern generator disabled (use video from the serializer input (default)).<br>0b01: Generate checkerboard pattern<br>0b10: Generate gradient pattern<br>0b11: Reserved                                  |
| VS_TRIG     | 0    | Select VS trigger edge          | 0b0: Falling edge<br>0b1: Rising edge  |

**VS\_DLY 2 (0x242)**

| BIT   | 7             | 6 | 5 | 4 | 3 | 2 | 1 | 0 |
|-------|---------------|---|---|---|---|---|---|---|
| Field | VS_DLY_2[7:0] |   |   |   |   |   |   |   |

|                    |             |
|--------------------|-------------|
| <b>Reset</b>       | 0x00        |
| <b>Access Type</b> | Write, Read |

| <b>BITFIELD</b> | <b>BITS</b> | <b>DESCRIPTION</b>   | <b>DECODE</b>                           |
|-----------------|-------------|--|---|
| VS_DLY_2        | 7:0         | VS delay in terms of PCLK cycles<br>The generated output VS is delayed by VS_DELAY cycles from the input VS. ([23:16]) | 0xXX: Most significant byte of VS delay |

**VS DLY 1 (0x243)**

| <b>BIT</b>         | <b>7</b>      | <b>6</b> | <b>5</b> | <b>4</b> | <b>3</b> | <b>2</b> | <b>1</b> | <b>0</b> |
|--------------------|---------------|----------|----------|----------|----------|----------|----------|----------|
| <b>Field</b>       | VS_DLY_1[7:0] |          |          |          |          |          |          |          |
| <b>Reset</b>       | 0x00          |          |          |          |          |          |          |          |
| <b>Access Type</b> | Write, Read   |          |          |          |          |          |          |          |

| <b>BITFIELD</b> | <b>BITS</b> | <b>DESCRIPTION</b>  | <b>DECODE</b>                             |
|-----------------|-------------|---|---|
| VS_DLY_1        | 7:0         | VS delay in terms of PCLK cycles<br>The generated output VS is delayed by VS_DELAY cycles from the input VS. ([15:8]) | 0xXX: Middle significant byte of VS delay |

**VS DLY 0 (0x244)**

| <b>BIT</b>         | <b>7</b>      | <b>6</b> | <b>5</b> | <b>4</b> | <b>3</b> | <b>2</b> | <b>1</b> | <b>0</b> |
|--------------------|---------------|----------|----------|----------|----------|----------|----------|----------|
| <b>Field</b>       | VS_DLY_0[7:0] |          |          |          |          |          |          |          |
| <b>Reset</b>       | 0x00          |          |          |          |          |          |          |          |
| <b>Access Type</b> | Write, Read   |          |          |          |          |          |          |          |

| <b>BITFIELD</b> | <b>BITS</b> | <b>DESCRIPTION</b>   | <b>DECODE</b>                            |
|-----------------|-------------|--|--|
| VS_DLY_0        | 7:0         | VS delay in terms of PCLK cycles<br>The generated output VS is delayed by VS_DELAY cycles from the input VS. ([7:0]) | 0xXX: Least significant byte of VS delay |

**VS\_HIGH\_2 (0x245)**

|                    |                |          |          |          |          |          |          |          |
|--------------------|----------------|----------|----------|----------|----------|----------|----------|----------|
| <b>BIT</b>         | <b>7</b>       | <b>6</b> | <b>5</b> | <b>4</b> | <b>3</b> | <b>2</b> | <b>1</b> | <b>0</b> |
| <b>Field</b>       | VS_HIGH_2[7:0] |          |          |          |          |          |          |          |
| <b>Reset</b>       | 0x00           |          |          |          |          |          |          |          |
| <b>Access Type</b> | Write, Read    |          |          |          |          |          |          |          |

| <b>BITFIELD</b> | <b>BITS</b> | <b>DESCRIPTION</b>                               | <b>DECODE</b>                                 |
|-----------------|-------------|--|---|
| VS_HIGH_2       | 7:0         | VS high period in terms of PCLK cycles ([23:16]) | 0xXX: Most significant byte of VS high period |

**VS\_HIGH\_1 (0x246)**

|                    |                |          |          |          |          |          |          |          |
|--------------------|----------------|----------|----------|----------|----------|----------|----------|----------|
| <b>BIT</b>         | <b>7</b>       | <b>6</b> | <b>5</b> | <b>4</b> | <b>3</b> | <b>2</b> | <b>1</b> | <b>0</b> |
| <b>Field</b>       | VS_HIGH_1[7:0] |          |          |          |          |          |          |          |
| <b>Reset</b>       | 0x00           |          |          |          |          |          |          |          |
| <b>Access Type</b> | Write, Read    |          |          |          |          |          |          |          |

| <b>BITFIELD</b> | <b>BITS</b> | <b>DESCRIPTION</b>                              | <b>DECODE</b>                                   |
|-----------------|-------------|---|---|
| VS_HIGH_1       | 7:0         | VS high period in terms of PCLK cycles ([15:8]) | 0xXX: Middle significant byte of VS high period |

**VS\_HIGH\_0 (0x247)**

|                    |                |          |          |          |          |          |          |          |
|--------------------|----------------|----------|----------|----------|----------|----------|----------|----------|
| <b>BIT</b>         | <b>7</b>       | <b>6</b> | <b>5</b> | <b>4</b> | <b>3</b> | <b>2</b> | <b>1</b> | <b>0</b> |
| <b>Field</b>       | VS_HIGH_0[7:0] |          |          |          |          |          |          |          |
| <b>Reset</b>       | 0x00           |          |          |          |          |          |          |          |
| <b>Access Type</b> | Write, Read    |          |          |          |          |          |          |          |

| <b>BITFIELD</b> | <b>BITS</b> | <b>DESCRIPTION</b>                             | <b>DECODE</b>                                  |
|-----------------|-------------|--|--|
| VS_HIGH_0       | 7:0         | VS high period in terms of PCLK cycles ([7:0]) | 0xXX: Least significant byte of VS high period |

**VS\_LOW\_2 (0x248)**

|              |               |          |          |          |          |          |          |          |
|--------------|---------------|----------|----------|----------|----------|----------|----------|----------|
| <b>BIT</b>   | <b>7</b>      | <b>6</b> | <b>5</b> | <b>4</b> | <b>3</b> | <b>2</b> | <b>1</b> | <b>0</b> |
| <b>Field</b> | VS_LOW_2[7:0] |          |          |          |          |          |          |          |

|                    |             |
|--------------------|-------------|
| <b>Reset</b>       | 0x00        |
| <b>Access Type</b> | Write, Read |

| <b>BITFIELD</b> | <b>BITS</b> | <b>DESCRIPTION</b>                              | <b>DECODE</b>                                |
|-----------------|-------------|---|--|
| VS_LOW_2        | 7:0         | VS low period in terms of PCLK cycles ([23:16]) | 0xXX: Most significant byte of VS low period |

**VS\_LOW\_1 (0x249)**

| <b>BIT</b>         | <b>7</b>      | <b>6</b> | <b>5</b> | <b>4</b> | <b>3</b> | <b>2</b> | <b>1</b> | <b>0</b> |
|--------------------|---------------|----------|----------|----------|----------|----------|----------|----------|
| <b>Field</b>       | VS_LOW_1[7:0] |          |          |          |          |          |          |          |
| <b>Reset</b>       | 0x00          |          |          |          |          |          |          |          |
| <b>Access Type</b> | Write, Read   |          |          |          |          |          |          |          |

| <b>BITFIELD</b> | <b>BITS</b> | <b>DESCRIPTION</b>                             | <b>DECODE</b>                                  |
|-----------------|-------------|--|--|
| VS_LOW_1        | 7:0         | VS low period in terms of PCLK cycles ([15:8]) | 0xXX: Middle significant byte of VS low period |

**VS\_LOW\_0 (0x24A)**

| <b>BIT</b>         | <b>7</b>      | <b>6</b> | <b>5</b> | <b>4</b> | <b>3</b> | <b>2</b> | <b>1</b> | <b>0</b> |
|--------------------|---------------|----------|----------|----------|----------|----------|----------|----------|
| <b>Field</b>       | VS_LOW_0[7:0] |          |          |          |          |          |          |          |
| <b>Reset</b>       | 0x00          |          |          |          |          |          |          |          |
| <b>Access Type</b> | Write, Read   |          |          |          |          |          |          |          |

| <b>BITFIELD</b> | <b>BITS</b> | <b>DESCRIPTION</b>                            | <b>DECODE</b>                                 |
|-----------------|-------------|---|---|
| VS_LOW_0        | 7:0         | VS low period in terms of PCLK cycles ([7:0]) | 0xXX: Least significant byte of VS low period |

**V2H\_2 (0x24B)**

| <b>BIT</b>         | <b>7</b>    | <b>6</b> | <b>5</b> | <b>4</b> | <b>3</b> | <b>2</b> | <b>1</b> | <b>0</b> |
|--------------------|-------------|----------|----------|----------|----------|----------|----------|----------|
| <b>Field</b>       | V2H_2[7:0]  |          |          |          |          |          |          |          |
| <b>Reset</b>       | 0x00        |          |          |          |          |          |          |          |
| <b>Access Type</b> | Write, Read |          |          |          |          |          |          |          |

| BITFIELD | BITS | DESCRIPTION  | DECODE   |
|----------|------|--|--|
| V2H_2    | 7:0  | VS edge to the rising edge of the first HS in terms of PCLK cycles ([23:16]) | 0xXX: Most significant byte of VS edge to first HS rising edge |

**V2H\_1 (0x24C)**

| BIT         | 7           | 6 | 5 | 4 | 3 | 2 | 1 | 0 |
|-------------|-------------|---|---|---|---|---|---|---|
| Field       | V2H_1[7:0]  |   |   |   |   |   |   |   |
| Reset       | 0x00        |   |   |   |   |   |   |   |
| Access Type | Write, Read |   |   |   |   |   |   |   |

| BITFIELD | BITS | DESCRIPTION   | DECODE   |
|----------|------|---|--|
| V2H_1    | 7:0  | VS edge to the rising edge of the first HS in terms of PCLK cycles ([15:8]) | 0xXX: Middle significant byte of VS edge to first HS rising edge |

**V2H\_0 (0x24D)**

| BIT         | 7           | 6 | 5 | 4 | 3 | 2 | 1 | 0 |
|-------------|-------------|---|---|---|---|---|---|---|
| Field       | V2H_0[7:0]  |   |   |   |   |   |   |   |
| Reset       | 0x00        |   |   |   |   |   |   |   |
| Access Type | Write, Read |   |   |   |   |   |   |   |

| BITFIELD | BITS | DESCRIPTION  | DECODE  |
|----------|------|--|---|
| V2H_0    | 7:0  | VS edge to the rising edge of the first HS in terms of PCLK cycles ([7:0]) | 0xXX: Least significant byte of VS edge to first HS rising edge |

**HS\_HIGH\_1 (0x24E)**

| BIT         | 7              | 6 | 5 | 4 | 3 | 2 | 1 | 0 |
|-------------|----------------|---|---|---|---|---|---|---|
| Field       | HS_HIGH_1[7:0] |   |   |   |   |   |   |   |
| Reset       | 0x00           |   |   |   |   |   |   |   |
| Access Type | Write, Read    |   |   |   |   |   |   |   |

| BITFIELD  | BITS | DESCRIPTION                                     | DECODE  |
|-----------|------|---|---|
| HS_HIGH_1 | 7:0  | HS high period in terms of PCLK cycles ([15:8]) | 0xXX: Most significant byte of HS high period |

**HS\_HIGH\_0 (0x24F)**

| BIT         | 7              | 6 | 5 | 4 | 3 | 2 | 1 | 0 |
|-------------|----------------|---|---|---|---|---|---|---|
| Field       | HS_HIGH_0[7:0] |   |   |   |   |   |   |   |
| Reset       | 0x00           |   |   |   |   |   |   |   |
| Access Type | Write, Read    |   |   |   |   |   |   |   |

| BITFIELD  | BITS | DESCRIPTION                                    | DECODE   |
|-----------|------|--|--|
| HS_HIGH_0 | 7:0  | HS high period in terms of PCLK cycles ([7:0]) | 0xXX: Least significant byte of HS high period |

**HS\_LOW\_1 (0x250)**

| BIT         | 7             | 6 | 5 | 4 | 3 | 2 | 1 | 0 |
|-------------|---------------|---|---|---|---|---|---|---|
| Field       | HS_LOW_1[7:0] |   |   |   |   |   |   |   |
| Reset       | 0x00          |   |   |   |   |   |   |   |
| Access Type | Write, Read   |   |   |   |   |   |   |   |

| BITFIELD | BITS | DESCRIPTION                                    | DECODE                                       |
|----------|------|--|--|
| HS_LOW_1 | 7:0  | HS low period in terms of PCLK cycles ([15:8]) | 0xXX: Most significant byte of HS low period |

**HS\_LOW\_0 (0x251)**

| BIT         | 7             | 6 | 5 | 4 | 3 | 2 | 1 | 0 |
|-------------|---------------|---|---|---|---|---|---|---|
| Field       | HS_LOW_0[7:0] |   |   |   |   |   |   |   |
| Reset       | 0x00          |   |   |   |   |   |   |   |
| Access Type | Write, Read   |   |   |   |   |   |   |   |

| BITFIELD | BITS | DESCRIPTION                                   | DECODE  |
|----------|------|---|---|
| HS_LOW_0 | 7:0  | HS low period in terms of PCLK cycles ([7:0]) | 0xXX: Least significant byte of HS low period |

**HS\_CNT\_1 (0x252)**

|                    |               |          |          |          |          |          |          |          |
|--------------------|---------------|----------|----------|----------|----------|----------|----------|----------|
| <b>BIT</b>         | <b>7</b>      | <b>6</b> | <b>5</b> | <b>4</b> | <b>3</b> | <b>2</b> | <b>1</b> | <b>0</b> |
| <b>Field</b>       | HS_CNT_1[7:0] |          |          |          |          |          |          |          |
| <b>Reset</b>       | 0x00          |          |          |          |          |          |          |          |
| <b>Access Type</b> | Write, Read   |          |          |          |          |          |          |          |

| <b>BITFIELD</b> | <b>BITS</b> | <b>DESCRIPTION</b>           | <b>DECODE</b>                                      |
|-----------------|-------------|------------------------------|--|
| HS_CNT_1        | 7:0         | HS pulses per frame ([15:8]) | 0xXX: Most significant byte of HS pulses per frame |

**HS\_CNT\_0 (0x253)**

|                    |               |          |          |          |          |          |          |          |
|--------------------|---------------|----------|----------|----------|----------|----------|----------|----------|
| <b>BIT</b>         | <b>7</b>      | <b>6</b> | <b>5</b> | <b>4</b> | <b>3</b> | <b>2</b> | <b>1</b> | <b>0</b> |
| <b>Field</b>       | HS_CNT_0[7:0] |          |          |          |          |          |          |          |
| <b>Reset</b>       | 0x00          |          |          |          |          |          |          |          |
| <b>Access Type</b> | Write, Read   |          |          |          |          |          |          |          |

| <b>BITFIELD</b> | <b>BITS</b> | <b>DESCRIPTION</b>        | <b>DECODE</b>                                       |
|-----------------|-------------|---------------------------|---|
| HS_CNT_0        | 7:0         | HS pulses per frame [7:0] | 0xXX: Least significant byte of HS pulses per frame |

**V2D\_2 (0x254)**

|                    |             |          |          |          |          |          |          |          |
|--------------------|-------------|----------|----------|----------|----------|----------|----------|----------|
| <b>BIT</b>         | <b>7</b>    | <b>6</b> | <b>5</b> | <b>4</b> | <b>3</b> | <b>2</b> | <b>1</b> | <b>0</b> |
| <b>Field</b>       | V2D_2[7:0]  |          |          |          |          |          |          |          |
| <b>Reset</b>       | 0x00        |          |          |          |          |          |          |          |
| <b>Access Type</b> | Write, Read |          |          |          |          |          |          |          |

| <b>BITFIELD</b> | <b>BITS</b> | <b>DESCRIPTION</b>   | <b>DECODE</b>                                      |
|-----------------|-------------|--|--|
| V2D_2           | 7:0         | VS edge to the rising edge of the first DE in terms of PCLK cycles ([23:16]) | 0xXX: Most significant byte of VS edge to first DE |

**V2D\_1 (0x255)**

|            |          |          |          |          |          |          |          |          |
|------------|----------|----------|----------|----------|----------|----------|----------|----------|
| <b>BIT</b> | <b>7</b> | <b>6</b> | <b>5</b> | <b>4</b> | <b>3</b> | <b>2</b> | <b>1</b> | <b>0</b> |
|------------|----------|----------|----------|----------|----------|----------|----------|----------|

|                    |             |
|--------------------|-------------|
| <b>Field</b>       | V2D_1[7:0]  |
| <b>Reset</b>       | 0x00        |
| <b>Access Type</b> | Write, Read |

| <b>BITFIELD</b> | <b>BITS</b> | <b>DESCRIPTION</b>  | <b>DECODE</b>  |
|-----------------|-------------|---|--|
| V2D_1           | 7:0         | VS edge to the rising edge of the first DE in terms of PCLK cycles ([15:8]) | 0xXX: Middle significant byte of VS edge to first DE |

**V2D\_0 (0x256)**

| <b>BIT</b>         | <b>7</b>    | <b>6</b> | <b>5</b> | <b>4</b> | <b>3</b> | <b>2</b> | <b>1</b> | <b>0</b> |
|--------------------|-------------|----------|----------|----------|----------|----------|----------|----------|
| <b>Field</b>       | V2D_0[7:0]  |          |          |          |          |          |          |          |
| <b>Reset</b>       | 0x00        |          |          |          |          |          |          |          |
| <b>Access Type</b> | Write, Read |          |          |          |          |          |          |          |

| <b>BITFIELD</b> | <b>BITS</b> | <b>DESCRIPTION</b>   | <b>DECODE</b>                                       |
|-----------------|-------------|--|---|
| V2D_0           | 7:0         | VS edge to the rising edge of the first DE in terms of PCLK cycles ([23:16]) | 0xXX: Least significant byte of VS edge to first DE |

**DE\_HIGH\_1 (0x257)**

| <b>BIT</b>         | <b>7</b>       | <b>6</b> | <b>5</b> | <b>4</b> | <b>3</b> | <b>2</b> | <b>1</b> | <b>0</b> |
|--------------------|----------------|----------|----------|----------|----------|----------|----------|----------|
| <b>Field</b>       | DE_HIGH_1[7:0] |          |          |          |          |          |          |          |
| <b>Reset</b>       | 0x00           |          |          |          |          |          |          |          |
| <b>Access Type</b> | Write, Read    |          |          |          |          |          |          |          |

| <b>BITFIELD</b> | <b>BITS</b> | <b>DESCRIPTION</b>                              | <b>DECODE</b>                                 |
|-----------------|-------------|---|---|
| DE_HIGH_1       | 7:0         | DE high period in terms of PCLK cycles ([15:8]) | 0xXX: Most significant byte of DE high period |

**DE\_HIGH\_0 (0x258)**

| <b>BIT</b>   | <b>7</b>       | <b>6</b> | <b>5</b> | <b>4</b> | <b>3</b> | <b>2</b> | <b>1</b> | <b>0</b> |
|--------------|----------------|----------|----------|----------|----------|----------|----------|----------|
| <b>Field</b> | DE_HIGH_0[7:0] |          |          |          |          |          |          |          |

|                    |             |
|--------------------|-------------|
| <b>Reset</b>       | 0x00        |
| <b>Access Type</b> | Write, Read |

| <b>BITFIELD</b> | <b>BITS</b> | <b>DESCRIPTION</b>                             | <b>DECODE</b>                                  |
|-----------------|-------------|--|--|
| DE_HIGH_0       | 7:0         | DE high period in terms of PCLK cycles ([7:0]) | 0xXX: Least significant byte of DE high period |

**DE LOW 1 (0x259)**

| <b>BIT</b>         | <b>7</b>      | <b>6</b> | <b>5</b> | <b>4</b> | <b>3</b> | <b>2</b> | <b>1</b> | <b>0</b> |
|--------------------|---------------|----------|----------|----------|----------|----------|----------|----------|
| <b>Field</b>       | DE_LOW_1[7:0] |          |          |          |          |          |          |          |
| <b>Reset</b>       | 0x00          |          |          |          |          |          |          |          |
| <b>Access Type</b> | Write, Read   |          |          |          |          |          |          |          |

| <b>BITFIELD</b> | <b>BITS</b> | <b>DESCRIPTION</b>                             | <b>DECODE</b>                                |
|-----------------|-------------|--|--|
| DE_LOW_1        | 7:0         | DE low period in terms of PCLK cycles ([15:8]) | 0xXX: Most significant byte of DE low period |

**DE LOW 0 (0x25A)**

| <b>BIT</b>         | <b>7</b>      | <b>6</b> | <b>5</b> | <b>4</b> | <b>3</b> | <b>2</b> | <b>1</b> | <b>0</b> |
|--------------------|---------------|----------|----------|----------|----------|----------|----------|----------|
| <b>Field</b>       | DE_LOW_0[7:0] |          |          |          |          |          |          |          |
| <b>Reset</b>       | 0x00          |          |          |          |          |          |          |          |
| <b>Access Type</b> | Write, Read   |          |          |          |          |          |          |          |

| <b>BITFIELD</b> | <b>BITS</b> | <b>DESCRIPTION</b>                            | <b>DECODE</b>                                 |
|-----------------|-------------|---|---|
| DE_LOW_0        | 7:0         | DE low period in terms of PCLK cycles ([7:0]) | 0xXX: Least significant byte of DE low period |

**DE CNT 1 (0x25B)**

| <b>BIT</b>         | <b>7</b>      | <b>6</b> | <b>5</b> | <b>4</b> | <b>3</b> | <b>2</b> | <b>1</b> | <b>0</b> |
|--------------------|---------------|----------|----------|----------|----------|----------|----------|----------|
| <b>Field</b>       | DE_CNT_1[7:0] |          |          |          |          |          |          |          |
| <b>Reset</b>       | 0x00          |          |          |          |          |          |          |          |
| <b>Access Type</b> | Write, Read   |          |          |          |          |          |          |          |

| BITFIELD | BITS | DESCRIPTION                     | DECODE   |
|----------|------|---------------------------------|--|
| DE_CNT_1 | 7:0  | Active lines per frame ([15:8]) | 0xXX: Most significant byte of DE pulses per frame |

**DE\_CNT\_0 (0x25C)**

| BIT         | 7             | 6 | 5 | 4 | 3 | 2 | 1 | 0 |
|-------------|---------------|---|---|---|---|---|---|---|
| Field       | DE_CNT_0[7:0] |   |   |   |   |   |   |   |
| Reset       | 0x00          |   |   |   |   |   |   |   |
| Access Type | Write, Read   |   |   |   |   |   |   |   |

| BITFIELD | BITS | DESCRIPTION                    | DECODE  |
|----------|------|--------------------------------|---|
| DE_CNT_0 | 7:0  | Active lines per frame ([7:0]) | 0xXX: Least significant byte of DE pulses per frame |

**GRAD\_INCR (0x25D)**

| BIT         | 7              | 6 | 5 | 4 | 3 | 2 | 1 | 0 |
|-------------|----------------|---|---|---|---|---|---|---|
| Field       | GRAD_INCR[7:0] |   |   |   |   |   |   |   |
| Reset       | 0x00           |   |   |   |   |   |   |   |
| Access Type | Write, Read    |   |   |   |   |   |   |   |

| BITFIELD  | BITS | DESCRIPTION   | DECODE                        |
|-----------|------|---|-------------------------------|
| GRAD_INCR | 7:0  | Gradient mode increment amount (increment amount is the register value divided by 4). Each successive pixel's value in a line increments by this amount divided by 4. | 0xXX: Gradient increment base |

**CHKR\_COLOR\_A\_L (0x25E)**

| BIT         | 7                   | 6 | 5 | 4 | 3 | 2 | 1 | 0 |
|-------------|---------------------|---|---|---|---|---|---|---|
| Field       | CHKR_COLOR_A_L[7:0] |   |   |   |   |   |   |   |
| Reset       | 0x00                |   |   |   |   |   |   |   |
| Access Type | Write, Read         |   |   |   |   |   |   |   |

| BITFIELD       | BITS | DESCRIPTION                        | DECODE  |
|----------------|------|------------------------------------|---|
| CHKR_COLOR_A_L | 7:0  | Checkerboard mode Color A low byte | 0xXX: Least significant byte of checkerboard mode Color A |

**CHKR\_COLOR\_A\_M (0x25F)**

| BIT         | 7                   | 6 | 5 | 4 | 3 | 2 | 1 | 0 |
|-------------|---------------------|---|---|---|---|---|---|---|
| Field       | CHKR_COLOR_A_M[7:0] |   |   |   |   |   |   |   |
| Reset       | 0x00                |   |   |   |   |   |   |   |
| Access Type | Write, Read         |   |   |   |   |   |   |   |

| BITFIELD       | BITS | DESCRIPTION                           | DECODE   |
|----------------|------|---------------------------------------|--|
| CHKR_COLOR_A_M | 7:0  | Checkerboard mode Color A middle byte | 0xXX: Middle significant byte of checkerboard mode Color A |

**CHKR\_COLOR\_A\_H (0x260)**

| BIT         | 7                   | 6 | 5 | 4 | 3 | 2 | 1 | 0 |
|-------------|---------------------|---|---|---|---|---|---|---|
| Field       | CHKR_COLOR_A_H[7:0] |   |   |   |   |   |   |   |
| Reset       | 0x00                |   |   |   |   |   |   |   |
| Access Type | Write, Read         |   |   |   |   |   |   |   |

| BITFIELD       | BITS | DESCRIPTION                         | DECODE   |
|----------------|------|-------------------------------------|--|
| CHKR_COLOR_A_H | 7:0  | Checkerboard mode Color A high byte | 0xXX: Most significant byte of checkerboard mode Color A |

**CHKR\_COLOR\_B\_L (0x261)**

| BIT         | 7                   | 6 | 5 | 4 | 3 | 2 | 1 | 0 |
|-------------|---------------------|---|---|---|---|---|---|---|
| Field       | CHKR_COLOR_B_L[7:0] |   |   |   |   |   |   |   |
| Reset       | 0x00                |   |   |   |   |   |   |   |
| Access Type | Write, Read         |   |   |   |   |   |   |   |

| BITFIELD       | BITS | DESCRIPTION                        | DECODE  |
|----------------|------|------------------------------------|---|
| CHKR_COLOR_B_L | 7:0  | Checkerboard mode Color B low byte | 0xXX: Least significant byte of checkerboard mode Color B |

**CHKR\_COLOR\_B\_M (0x262)**

|                    |                     |          |          |          |          |          |          |          |
|--------------------|---------------------|----------|----------|----------|----------|----------|----------|----------|
| <b>BIT</b>         | <b>7</b>            | <b>6</b> | <b>5</b> | <b>4</b> | <b>3</b> | <b>2</b> | <b>1</b> | <b>0</b> |
| <b>Field</b>       | CHKR_COLOR_B_M[7:0] |          |          |          |          |          |          |          |
| <b>Reset</b>       | 0x00                |          |          |          |          |          |          |          |
| <b>Access Type</b> | Write, Read         |          |          |          |          |          |          |          |

| <b>BITFIELD</b> | <b>BITS</b> | <b>DESCRIPTION</b>                    | <b>DECODE</b>  |
|-----------------|-------------|---------------------------------------|--|
| CHKR_COLOR_B_M  | 7:0         | Checkerboard mode Color B middle byte | 0xXX: Middle significant byte of checkerboard mode Color B |

**CHKR\_COLOR\_B\_H (0x263)**

|                    |                     |          |          |          |          |          |          |          |
|--------------------|---------------------|----------|----------|----------|----------|----------|----------|----------|
| <b>BIT</b>         | <b>7</b>            | <b>6</b> | <b>5</b> | <b>4</b> | <b>3</b> | <b>2</b> | <b>1</b> | <b>0</b> |
| <b>Field</b>       | CHKR_COLOR_B_H[7:0] |          |          |          |          |          |          |          |
| <b>Reset</b>       | 0x00                |          |          |          |          |          |          |          |
| <b>Access Type</b> | Write, Read         |          |          |          |          |          |          |          |

| <b>BITFIELD</b> | <b>BITS</b> | <b>DESCRIPTION</b>                  | <b>DECODE</b>  |
|-----------------|-------------|-------------------------------------|--|
| CHKR_COLOR_B_H  | 7:0         | Checkerboard mode Color B high byte | 0xXX: Most significant byte of checkerboard mode Color B |

**CHKR\_RPT\_A (0x264)**

|                    |                 |          |          |          |          |          |          |          |
|--------------------|-----------------|----------|----------|----------|----------|----------|----------|----------|
| <b>BIT</b>         | <b>7</b>        | <b>6</b> | <b>5</b> | <b>4</b> | <b>3</b> | <b>2</b> | <b>1</b> | <b>0</b> |
| <b>Field</b>       | CHKR_RPT_A[7:0] |          |          |          |          |          |          |          |
| <b>Reset</b>       | 0x00            |          |          |          |          |          |          |          |
| <b>Access Type</b> | Write, Read     |          |          |          |          |          |          |          |

| <b>BITFIELD</b> | <b>BITS</b> | <b>DESCRIPTION</b>                     | <b>DECODE</b>                                   |
|-----------------|-------------|--|---|
| CHKR_RPT_A      | 7:0         | Checkerboard mode Color A repeat count | 0xXX: Repeat count of checkerboard mode Color A |

**CHKR\_RPT\_B (0x265)**

|              |                 |          |          |          |          |          |          |          |
|--------------|-----------------|----------|----------|----------|----------|----------|----------|----------|
| <b>BIT</b>   | <b>7</b>        | <b>6</b> | <b>5</b> | <b>4</b> | <b>3</b> | <b>2</b> | <b>1</b> | <b>0</b> |
| <b>Field</b> | CHKR_RPT_B[7:0] |          |          |          |          |          |          |          |

|                    |             |
|--------------------|-------------|
| <b>Reset</b>       | 0x00        |
| <b>Access Type</b> | Write, Read |

| <b>BITFIELD</b> | <b>BITS</b> | <b>DESCRIPTION</b>                     | <b>DECODE</b>                                   |
|-----------------|-------------|--|---|
| CHKR_RPT_B      | 7:0         | Checkerboard mode Color B repeat count | 0xXX: Repeat count of checkerboard mode Color B |

**CHKR\_ALT (0x266)**

| <b>BIT</b>         | <b>7</b>      | <b>6</b> | <b>5</b> | <b>4</b> | <b>3</b> | <b>2</b> | <b>1</b> | <b>0</b> |
|--------------------|---------------|----------|----------|----------|----------|----------|----------|----------|
| <b>Field</b>       | CHKR_ALT[7:0] |          |          |          |          |          |          |          |
| <b>Reset</b>       | 0x00          |          |          |          |          |          |          |          |
| <b>Access Type</b> | Write, Read   |          |          |          |          |          |          |          |

| <b>BITFIELD</b> | <b>BITS</b> | <b>DESCRIPTION</b>  | <b>DECODE</b>                                |
|-----------------|-------------|---|--|
| CHKR_ALT        | 7:0         | Checkerboard mode alternate line count. Number of successive video lines that have the color A before switching to color B, and vice versa. | 0xXX: Checkerboard mode alternate line count |

**GPIO A (0x2B0)**

## GPIO 0

| <b>BIT</b>         | <b>7</b>    | <b>6</b> | <b>5</b>    | <b>4</b>    | <b>3</b>  | <b>2</b>    | <b>1</b>    | <b>0</b>     |
|--------------------|-------------|----------|-------------|-------------|-----------|-------------|-------------|--------------|
| <b>Field</b>       | RES_CFG     | –        | TX_COMP_EN  | GPIO_OUT    | GPIO_IN   | GPIO_RX_EN  | GPIO_TX_EN  | GPIO_OUT_DIS |
| <b>Reset</b>       | 0b1         | –        | 0b0         | 0b0         | 0b0       | 0b0         | 0b1         | 0b1          |
| <b>Access Type</b> | Write, Read | –        | Write, Read | Write, Read | Read Only | Write, Read | Write, Read | Write, Read  |

| <b>BITFIELD</b> | <b>BITS</b> | <b>DESCRIPTION</b>  | <b>DECODE</b>   |
|-----------------|-------------|---|---|
| RES_CFG         | 7           | Pull-Up/Pull-Down Resistor Strength   | 0b0: 40kΩ<br>0b1: 1MΩ   |
| TX_COMP_EN      | 5           | Enables jitter minimization compensation  | 0b0: Jitter compensation disabled<br>0b1: Jitter compensation enabled                                 |
| GPIO_OUT        | 4           | GPIO pin output drive value when GPIO_RX_EN = 0. This can be used to drive a value out on an MFP.   | 0b0: This GPIO pin output is driven to 0<br>0b1: This GPIO pin output is driven to 1                  |
| GPIO_IN         | 3           | GPIO pin local MFP input level  | 0b0: This GPIO pin value is 0<br>0b1: This GPIO pin value is 1  |
| GPIO_RX_EN      | 2           | GPIO out source control.<br>Set to 1 to receive GPIO value from GMSL link. Set GPIO_OUT_DIS to 0 to output the received value on the local MFP. | 0b0: This GPIO source disabled for GMSL reception<br>0b1: This GPIO source enabled for GMSL reception |

| BITFIELD     | BITS | DESCRIPTION                 | DECODE  |
|--------------|------|-----------------------------|---|
| GPIO_TX_EN   | 1    | GPIO Tx source control      | 0b0: This GPIO source disabled for GMSL transmission<br>0b1: This GPIO source enabled for GMSL transmission |
| GPIO_OUT_DIS | 0    | Disables GPIO output driver | 0b0: Output driver enabled<br>0b1: Output driver disabled   |

**GPIO B (0x2B1)**

## GPIO 0

| BIT         | 7                  | 6 | 5           | 4               | 3 | 2 | 1 | 0 |
|-------------|--------------------|---|-------------|-----------------|---|---|---|---|
| Field       | PULL_UPDN_SEL[1:0] |   | OUT_TYPE    | GPIO_TX_ID[4:0] |   |   |   |   |
| Reset       | 0b10               |   | 0b1         | 0b00000         |   |   |   |   |
| Access Type | Write, Read        |   | Write, Read | Write, Read     |   |   |   |   |

| BITFIELD      | BITS | DESCRIPTION                            | DECODE   |
|---------------|------|--|--|
| PULL_UPDN_SEL | 7:6  | Buffer Pull-Up/Pull-Down Configuration | 0b00: None<br>0b01: Pull-up<br>0b10: Pull-down<br>0b11: Reserved |
| OUT_TYPE      | 5    | Driver type selection                  | 0b0: Open-drain<br>0b1: Push-pull                                |
| GPIO_TX_ID    | 4:0  | GPIO ID for pin while transmitting     | 0bXXXXX: This GPIO transmit ID                                   |

**GPIO C (0x2B2)**

## GPIO 0

| BIT         | 7           | 6           | 5 | 4               | 3 | 2 | 1 | 0 |
|-------------|-------------|-------------|---|-----------------|---|---|---|---|
| Field       | OVR_RES_CFG | GPIO_RECVED | – | GPIO_RX_ID[4:0] |   |   |   |   |
| Reset       | 0b0         | 0b1         | – | 0b00000         |   |   |   |   |
| Access Type | Write, Read | Write, Read | – | Write, Read     |   |   |   |   |

| BITFIELD    | BITS | DESCRIPTION  | DECODE  |
|-------------|------|--|---|
| OVR_RES_CFG | 7    | Override non-GPIO port function IO setting.<br><br>When set, RES_CFG, PULL_UPDN_SEL, OUT_TYPE, and GPIO_OUT_DIS are effective when pin is configured as non-GPIO.<br><br>When cleared, non-GPIO pin function determines IO type. | 0b0: Non-GPIO function determines IO type when alternate function is selected<br>0b1: RES_CFG, PULL_UPDN_SEL, OUT_TYPE, and GPIO_OUT_DIS determine IO type for non-GPIO configuration |
| GPIO_RECVED | 6    | Received GPIO value from across the GMSL link  |   |
| GPIO_RX_ID  | 4:0  | GPIO ID for pin while receiving  | 0bXXXXX: This GPIO receive ID   |

**GPIO A (0x2B3)**

## GPIO 1

| BIT         | 7           | 6 | 5           | 4           | 3         | 2           | 1           | 0            |
|-------------|-------------|---|-------------|-------------|-----------|-------------|-------------|--------------|
| Field       | RES_CFG     | – | TX_COMP_EN  | GPIO_OUT    | GPIO_IN   | GPIO_RX_EN  | GPIO_TX_EN  | GPIO_OUT_DIS |
| Reset       | 0b1         | – | 0b0         | 0b0         | 0b0       | 0b1         | 0b0         | 0b0          |
| Access Type | Write, Read | – | Write, Read | Write, Read | Read Only | Write, Read | Write, Read | Write, Read  |

| BITFIELD     | BITS | DESCRIPTION   | DECODE  |
|--------------|------|---|---|
| RES_CFG      | 7    | Pull-Up/Pull-Down Resistor Strength   | 0b0: 40kΩ<br>0b1: 1MΩ   |
| TX_COMP_EN   | 5    | Enables jitter minimization compensation  | 0b0: Jitter compensation disabled<br>0b1: Jitter compensation enabled                                       |
| GPIO_OUT     | 4    | GPIO pin output drive value when GPIO_RX_EN = 0. This can be used to drive a value out on an MFP.   | 0b0: This GPIO pin output is driven to 0<br>0b1: This GPIO pin output is driven to 1                        |
| GPIO_IN      | 3    | GPIO pin local MFP input level  | 0b0: This GPIO pin value is 0<br>0b1: This GPIO pin value is 1  |
| GPIO_RX_EN   | 2    | GPIO out source control.<br>Set to 1 to receive GPIO value from GMSL link. Set GPIO_OUT_DIS to 0 to output the received value on the local MFP. | 0b0: This GPIO source disabled for GMSL reception<br>0b1: This GPIO source enabled for GMSL reception       |
| GPIO_TX_EN   | 1    | GPIO Tx source control.<br>Set to 1 to transmit the local MFP input value across the GMSL link.   | 0b0: This GPIO source disabled for GMSL transmission<br>0b1: This GPIO source enabled for GMSL transmission |
| GPIO_OUT_DIS | 0    | Disables GPIO output driver   | 0b0: Output driver enabled<br>0b1: Output driver disabled   |

**GPIO B (0x2B4)**

## GPIO 1

| BIT         | 7                  | 6 | 5           | 4               | 3 | 2 | 1 | 0 |
|-------------|--------------------|---|-------------|-----------------|---|---|---|---|
| Field       | PULL_UPDN_SEL[1:0] |   | OUT_TYPE    | GPIO_TX_ID[4:0] |   |   |   |   |
| Reset       | 0b10               |   | 0b1         | 0b00001         |   |   |   |   |
| Access Type | Write, Read        |   | Write, Read | Write, Read     |   |   |   |   |

| BITFIELD      | BITS | DESCRIPTION                            | DECODE   |
|---------------|------|--|--|
| PULL_UPDN_SEL | 7:6  | Buffer Pull-Up/Pull-Down Configuration | 0b00: None<br>0b01: Pull-up<br>0b10: Pull-down<br>0b11: Reserved |
| OUT_TYPE      | 5    | Driver type selection                  | 0b0: Open-drain<br>0b1: Push-pull                                |
| GPIO_TX_ID    | 4:0  | GPIO ID for pin while transmitting     | 0bXXXXX: This GPIO transmit ID                                   |

**GPIO C (0x2B5)**

## GPIO 1

| BIT         | 7           | 6 | 5 | 4               | 3 | 2 | 1 | 0 |
|-------------|-------------|---|---|-----------------|---|---|---|---|
| Field       | OVR_RES_CFG | – | – | GPIO_RX_ID[4:0] |   |   |   |   |
| Reset       | 0b0         | – | – | 0b00001         |   |   |   |   |
| Access Type | Write, Read | – | – | Write, Read     |   |   |   |   |

| BITFIELD    | BITS | DESCRIPTION  | DECODE  |
|-------------|------|--|---|
| OVR_RES_CFG | 7    | Override non-GPIO port function IO setting.<br><br>When set, RES_CFG, PULL_UPDN_SEL, OUT_TYPE, and GPIO_OUT_DIS are effective when pin is configured as non-GPIO.<br><br>When cleared, non-GPIO pin function determines IO type. | 0b0: Non-GPIO function determines IO type when alternate function is selected<br>0b1: RES_CFG, PULL_UPDN_SEL, OUT_TYPE, and GPIO_OUT_DIS determine IO type for non-GPIO configuration |
| GPIO_RX_ID  | 4:0  | GPIO ID for pin while receiving  | 0bXXXXX: This GPIO receive ID   |

**GPIO A (0x2B6)**

## GPIO 2

| BIT         | 7           | 6 | 5           | 4           | 3         | 2           | 1           | 0            |
|-------------|-------------|---|-------------|-------------|-----------|-------------|-------------|--------------|
| Field       | RES_CFG     | – | TX_COMP_EN  | GPIO_OUT    | GPIO_IN   | GPIO_RX_EN  | GPIO_TX_EN  | GPIO_OUT_DIS |
| Reset       | 0b1         | – | 0b0         | 0b0         | 0b0       | 0b0         | 0b0         | 0b1          |
| Access Type | Write, Read | – | Write, Read | Write, Read | Read Only | Write, Read | Write, Read | Write, Read  |

| BITFIELD     | BITS | DESCRIPTION   | DECODE  |
|--------------|------|---|---|
| RES_CFG      | 7    | Pull-Up/Pull-Down Resistor Strength   | 0b0: 40kΩ<br>0b1: 1MΩ   |
| TX_COMP_EN   | 5    | Enables jitter minimization compensation  | 0b0: Jitter compensation disabled<br>0b1: Jitter compensation enabled                                       |
| GPIO_OUT     | 4    | GPIO pin output drive value when GPIO_RX_EN = 0. This can be used to drive a value out on an MFP.   | 0b0: This GPIO pin output is driven to 0<br>0b1: This GPIO pin output is driven to 1                        |
| GPIO_IN      | 3    | GPIO pin local MFP input level  | 0b0: This GPIO pin value is 0<br>0b1: This GPIO pin value is 1  |
| GPIO_RX_EN   | 2    | GPIO out source control.<br>Set to 1 to receive GPIO value from GMSL link. Set GPIO_OUT_DIS to 0 to output the received value on the local MFP. | 0b0: This GPIO source disabled for GMSL reception<br>0b1: This GPIO source enabled for GMSL reception       |
| GPIO_TX_EN   | 1    | GPIO Tx source control.<br>Set to 1 to transmit the local MFP input value across the GMSL link.   | 0b0: This GPIO source disabled for GMSL transmission<br>0b1: This GPIO source enabled for GMSL transmission |
| GPIO_OUT_DIS | 0    | Disables GPIO output driver   | 0b0: Output driver enabled<br>0b1: Output driver disabled   |

**GPIO B (0x2B7)**

## GPIO 2

| BIT         | 7                  | 6 | 5           | 4               | 3 | 2 | 1 | 0 |
|-------------|--------------------|---|-------------|-----------------|---|---|---|---|
| Field       | PULL_UPDN_SEL[1:0] |   | OUT_TYPE    | GPIO_TX_ID[4:0] |   |   |   |   |
| Reset       | 0b00               |   | 0b1         | 0b00010         |   |   |   |   |
| Access Type | Write, Read        |   | Write, Read | Write, Read     |   |   |   |   |

| BITFIELD      | BITS | DESCRIPTION                            | DECODE   |
|---------------|------|--|--|
| PULL_UPDN_SEL | 7:6  | Buffer Pull-Up/Pull-Down Configuration | 0b00: None<br>0b01: Pull-up<br>0b10: Pull-down<br>0b11: Reserved |
| OUT_TYPE      | 5    | Driver type selection                  | 0b0: Open-drain<br>0b1: Push-pull                                |
| GPIO_TX_ID    | 4:0  | GPIO ID for pin while transmitting     | 0bXXXXX: This GPIO transmit ID                                   |

**GPIO C (0x2B8)**

## GPIO 2

| BIT         | 7           | 6 | 5 | 4               | 3 | 2 | 1 | 0 |
|-------------|-------------|---|---|-----------------|---|---|---|---|
| Field       | OVR_RES_CFG | – | – | GPIO_RX_ID[4:0] |   |   |   |   |
| Reset       | 0b0         | – | – | 0b00010         |   |   |   |   |
| Access Type | Write, Read | – | – | Write, Read     |   |   |   |   |

| BITFIELD    | BITS | DESCRIPTION  | DECODE  |
|-------------|------|--|---|
| OVR_RES_CFG | 7    | Override non-GPIO port function IO setting.<br><br>When set, RES_CFG, PULL_UPDN_SEL, OUT_TYPE, and GPIO_OUT_DIS are effective when pin is configured as non-GPIO.<br><br>When cleared, non-GPIO pin function determines IO type. | 0b0: Non-GPIO function determines IO type when alternate function is selected<br>0b1: RES_CFG, PULL_UPDN_SEL, OUT_TYPE, and GPIO_OUT_DIS determine IO type for non-GPIO configuration |
| GPIO_RX_ID  | 4:0  | GPIO ID for pin while receiving  | 0bXXXXX: This GPIO receive ID   |

**GPIO A (0x2B9)**

## GPIO 3

| BIT   | 7       | 6 | 5          | 4        | 3       | 2          | 1          | 0            |
|-------|---------|---|------------|----------|---------|------------|------------|--------------|
| Field | RES_CFG | – | TX_COMP_EN | GPIO_OUT | GPIO_IN | GPIO_RX_EN | GPIO_TX_EN | GPIO_OUT_DIS |
| Reset | 0b1     | – | 0b0        | 0b0      | 0b0     | 0b0        | 0b0        | 0b1          |

|                    |             |   |             |             |           |             |             |             |
|--------------------|-------------|---|-------------|-------------|-----------|-------------|-------------|-------------|
| <b>Access Type</b> | Write, Read | – | Write, Read | Write, Read | Read Only | Write, Read | Write, Read | Write, Read |
|--------------------|-------------|---|-------------|-------------|-----------|-------------|-------------|-------------|

| BITFIELD     | BITS | DESCRIPTION   | DECODE  |
|--------------|------|---|---|
| RES_CFG      | 7    | Pull-Up/Pull-Down Resistor Strength   | 0b0: 40kΩ<br>0b1: 1MΩ   |
| TX_COMP_EN   | 5    | Enables jitter minimization compensation  | 0b0: Jitter compensation disabled<br>0b1: Jitter compensation enabled                                       |
| GPIO_OUT     | 4    | GPIO pin output drive value when GPIO_RX_EN = 0. This can be used to drive a value out on an MFP.   | 0b0: This GPIO pin output is driven to 0<br>0b1: This GPIO pin output is driven to 1                        |
| GPIO_IN      | 3    | GPIO pin local MFP input level  | 0b0: This GPIO pin value is 0<br>0b1: This GPIO pin value is 1  |
| GPIO_RX_EN   | 2    | GPIO out source control.<br>Set to 1 to receive GPIO value from GMSL link. Set GPIO_OUT_DIS to 0 to output the received value on the local MFP. | 0b0: This GPIO source disabled for GMSL reception<br>0b1: This GPIO source enabled for GMSL reception       |
| GPIO_TX_EN   | 1    | GPIO Tx source control.<br>Set to 1 to transmit the local MFP input value across the GMSL link.   | 0b0: This GPIO source disabled for GMSL transmission<br>0b1: This GPIO source enabled for GMSL transmission |
| GPIO_OUT_DIS | 0    | Disables GPIO output driver   | 0b0: Output driver enabled<br>0b1: Output driver disabled   |

### GPIO B (0x2BA)

#### GPIO 3

| BIT                | 7                  | 6 | 5           | 4               | 3 | 2 | 1 | 0 |
|--------------------|--------------------|---|-------------|-----------------|---|---|---|---|
| <b>Field</b>       | PULL_UPDN_SEL[1:0] |   | OUT_TYPE    | GPIO_TX_ID[4:0] |   |   |   |   |
| <b>Reset</b>       | 0b00               |   | 0b1         | 0b00011         |   |   |   |   |
| <b>Access Type</b> | Write, Read        |   | Write, Read | Write, Read     |   |   |   |   |

| BITFIELD      | BITS | DESCRIPTION                            | DECODE   |
|---------------|------|--|--|
| PULL_UPDN_SEL | 7:6  | Buffer Pull-Up/Pull-Down Configuration | 0b00: None<br>0b01: Pull-up<br>0b10: Pull-down<br>0b11: Reserved |
| OUT_TYPE      | 5    | Driver type selection                  | 0b0: Open-drain<br>0b1: Push-pull                                |
| GPIO_TX_ID    | 4:0  | GPIO ID for pin while transmitting     | 0bXXXXX: This GPIO transmit ID                                   |

### GPIO C (0x2BB)

#### GPIO 3

| BIT          | 7           | 6 | 5 | 4               | 3 | 2 | 1 | 0 |
|--------------|-------------|---|---|-----------------|---|---|---|---|
| <b>Field</b> | OVR_RES_CFG | – | – | GPIO_RX_ID[4:0] |   |   |   |   |
| <b>Reset</b> | 0b0         | – | – | 0b00011         |   |   |   |   |

|                    |             |   |   |             |
|--------------------|-------------|---|---|-------------|
| <b>Access Type</b> | Write, Read | – | – | Write, Read |
|--------------------|-------------|---|---|-------------|

| BITFIELD    | BITS | DESCRIPTION  | DECODE  |
|-------------|------|--|---|
| OVR_RES_CFG | 7    | Override non-GPIO port function IO setting.<br><br>When set, RES_CFG, PULL_UPDN_SEL, OUT_TYPE, and GPIO_OUT_DIS are effective when pin is configured as non-GPIO.<br><br>When cleared, non-GPIO pin function determines IO type. | 0b0: Non-GPIO function determines IO type when alternate function is selected<br>0b1: RES_CFG, PULL_UPDN_SEL, OUT_TYPE, and GPIO_OUT_DIS determine IO type for non-GPIO configuration |
| GPIO_RX_ID  | 4:0  | GPIO ID for pin while receiving  | 0bXXXXX: This GPIO receive ID   |

**GPIO A (0x2BC)**

## GPIO 4

| BIT                | 7           | 6 | 5           | 4           | 3         | 2           | 1           | 0            |
|--------------------|-------------|---|-------------|-------------|-----------|-------------|-------------|--------------|
| <b>Field</b>       | RES_CFG     | – | TX_COMP_EN  | GPIO_OUT    | GPIO_IN   | GPIO_RX_EN  | GPIO_TX_EN  | GPIO_OUT_DIS |
| <b>Reset</b>       | 0b1         | – | 0b0         | 0b0         | 0b0       | 0b0         | 0b0         | 0b1          |
| <b>Access Type</b> | Write, Read | – | Write, Read | Write, Read | Read Only | Write, Read | Write, Read | Write, Read  |

| BITFIELD     | BITS | DESCRIPTION   | DECODE  |
|--------------|------|---|---|
| RES_CFG      | 7    | Pull-Up/Pull-Down Resistor Strength   | 0b0: 40kΩ<br>0b1: 1MΩ   |
| TX_COMP_EN   | 5    | Enables jitter minimization compensation  | 0b0: Jitter compensation disabled<br>0b1: Jitter compensation enabled                                       |
| GPIO_OUT     | 4    | GPIO pin output drive value when GPIO_RX_EN = 0. This can be used to drive a value out on an MFP.   | 0b0: This GPIO pin output is driven to 0<br>0b1: This GPIO pin output is driven to 1                        |
| GPIO_IN      | 3    | GPIO pin local MFP input level  | 0b0: This GPIO pin value is 0<br>0b1: This GPIO pin value is 1  |
| GPIO_RX_EN   | 2    | GPIO out source control.<br>Set to 1 to receive GPIO value from GMSL link. Set GPIO_OUT_DIS to 0 to output the received value on the local MFP. | 0b0: This GPIO source disabled for GMSL reception<br>0b1: This GPIO source enabled for GMSL reception       |
| GPIO_TX_EN   | 1    | GPIO Tx source control.<br>Set to 1 to transmit the local MFP input value across the GMSL link.   | 0b0: This GPIO source disabled for GMSL transmission<br>0b1: This GPIO source enabled for GMSL transmission |
| GPIO_OUT_DIS | 0    | Disables GPIO output driver   | 0b0: Output driver enabled<br>0b1: Output driver disabled   |

**GPIO B (0x2BD)**

## GPIO 4

| BIT          | 7                  | 6 | 5        | 4               | 3 | 2 | 1 | 0 |
|--------------|--------------------|---|----------|-----------------|---|---|---|---|
| <b>Field</b> | PULL_UPDN_SEL[1:0] |   | OUT_TYPE | GPIO_TX_ID[4:0] |   |   |   |   |
| <b>Reset</b> | 0b10               |   | 0b1      | 0b00100         |   |   |   |   |

|                    |             |             |             |
|--------------------|-------------|-------------|-------------|
| <b>Access Type</b> | Write, Read | Write, Read | Write, Read |
|--------------------|-------------|-------------|-------------|

| BITFIELD      | BITS | DESCRIPTION                            | DECODE   |
|---------------|------|--|--|
| PULL_UPDN_SEL | 7:6  | Buffer Pull-Up/Pull-Down Configuration | 0b00: None<br>0b01: Pull-up<br>0b10: Pull-down<br>0b11: Reserved |
| OUT_TYPE      | 5    | Driver type selection                  | 0b0: Open-drain<br>0b1: Push-pull                                |
| GPIO_TX_ID    | 4:0  | GPIO ID for pin while transmitting     | 0bXXXXX: This GPIO transmit ID                                   |

### GPIO C (0x2BE)

#### GPIO 4

| BIT                | 7           | 6 | 5 | 4               | 3 | 2 | 1 | 0 |
|--------------------|-------------|---|---|-----------------|---|---|---|---|
| <b>Field</b>       | OVR_RES_CFG | – | – | GPIO_RX_ID[4:0] |   |   |   |   |
| <b>Reset</b>       | 0b0         | – | – | 0b00100         |   |   |   |   |
| <b>Access Type</b> | Write, Read | – | – | Write, Read     |   |   |   |   |

| BITFIELD    | BITS | DESCRIPTION  | DECODE  |
|-------------|------|--|---|
| OVR_RES_CFG | 7    | Override non-GPIO port function IO setting.<br><br>When set, RES_CFG, PULL_UPDN_SEL, OUT_TYPE, and GPIO_OUT_DIS are effective when pin is configured as non-GPIO.<br><br>When cleared, non-GPIO pin function determines IO type. | 0b0: Non-GPIO function determines IO type when alternate function is selected<br>0b1: RES_CFG, PULL_UPDN_SEL, OUT_TYPE, and GPIO_OUT_DIS determine IO type for non-GPIO configuration |
| GPIO_RX_ID  | 4:0  | GPIO ID for pin while receiving  | 0bXXXXX: This GPIO receive ID   |

### GPIO A (0x2BF)

#### GPIO 5

| BIT                | 7           | 6 | 5           | 4           | 3         | 2           | 1           | 0            |
|--------------------|-------------|---|-------------|-------------|-----------|-------------|-------------|--------------|
| <b>Field</b>       | RES_CFG     | – | TX_COMP_EN  | GPIO_OUT    | GPIO_IN   | GPIO_RX_EN  | GPIO_TX_EN  | GPIO_OUT_DIS |
| <b>Reset</b>       | 0b1         | – | 0b0         | 0b0         | 0b0       | 0b1         | 0b0         | 0b0          |
| <b>Access Type</b> | Write, Read | – | Write, Read | Write, Read | Read Only | Write, Read | Write, Read | Write, Read  |

| BITFIELD | BITS | DESCRIPTION                         | DECODE                |
|----------|------|-------------------------------------|-----------------------|
| RES_CFG  | 7    | Pull-Up/Pull-Down Resistor Strength | 0b0: 40kΩ<br>0b1: 1MΩ |

| BITFIELD     | BITS | DESCRIPTION   | DECODE  |
|--------------|------|---|---|
| TX_COMP_EN   | 5    | Enables jitter minimization compensation  | 0b0: Jitter compensation disabled<br>0b1: Jitter compensation enabled                                       |
| GPIO_OUT     | 4    | GPIO pin output drive value when GPIO_RX_EN = 0. This can be used to drive a value out on an MFP.   | 0b0: This GPIO pin output is driven to 0<br>0b1: This GPIO pin output is driven to 1                        |
| GPIO_IN      | 3    | GPIO pin local MFP input level  | 0b0: This GPIO pin value is 0<br>0b1: This GPIO pin value is 1  |
| GPIO_RX_EN   | 2    | GPIO out source control.<br>Set to 1 to receive GPIO value from GMSL link. Set GPIO_OUT_DIS to 0 to output the received value on the local MFP. | 0b0: This GPIO source disabled for GMSL reception<br>0b1: This GPIO source enabled for GMSL reception       |
| GPIO_TX_EN   | 1    | GPIO Tx source control.<br>Set to 1 to transmit the local MFP input value across the GMSL link.   | 0b0: This GPIO source disabled for GMSL transmission<br>0b1: This GPIO source enabled for GMSL transmission |
| GPIO_OUT_DIS | 0    | Disables GPIO output driver   | 0b0: Output driver enabled<br>0b1: Output driver disabled   |

### GPIO B (0x2C0)

GPIO 5

| BIT         | 7                  | 6 | 5           | 4               | 3 | 2 | 1 | 0 |
|-------------|--------------------|---|-------------|-----------------|---|---|---|---|
| Field       | PULL_UPDN_SEL[1:0] |   | OUT_TYPE    | GPIO_TX_ID[4:0] |   |   |   |   |
| Reset       | 0b10               |   | 0b1         | 0b00101         |   |   |   |   |
| Access Type | Write, Read        |   | Write, Read | Write, Read     |   |   |   |   |

| BITFIELD      | BITS | DESCRIPTION                            | DECODE   |
|---------------|------|--|--|
| PULL_UPDN_SEL | 7:6  | Buffer Pull-Up/Pull-Down Configuration | 0b00: None<br>0b01: Pull-up<br>0b10: Pull-down<br>0b11: Reserved |
| OUT_TYPE      | 5    | Driver type selection                  | 0b0: Open-drain<br>0b1: Push-pull                                |
| GPIO_TX_ID    | 4:0  | GPIO ID for pin while transmitting     | 0bXXXXX: This GPIO transmit ID                                   |

### GPIO C (0x2C1)

GPIO 5

| BIT         | 7           | 6 | 5 | 4               | 3 | 2 | 1 | 0 |
|-------------|-------------|---|---|-----------------|---|---|---|---|
| Field       | OVR_RES_CFG | – | – | GPIO_RX_ID[4:0] |   |   |   |   |
| Reset       | 0b0         | – | – | 0b00101         |   |   |   |   |
| Access Type | Write, Read | – | – | Write, Read     |   |   |   |   |

| BITFIELD    | BITS | DESCRIPTION  | DECODE  |
|-------------|------|--|---|
| OVR_RES_CFG | 7    | Override non-GPIO port function IO setting.<br><br>When set, RES_CFG, PULL_UPDN_SEL, OUT_TYPE, and GPIO_OUT_DIS are effective when pin is configured as non-GPIO.<br><br>When cleared, non-GPIO pin function determines IO type. | 0b0: Non-GPIO function determines IO type when alternate function is selected<br>0b1: RES_CFG, PULL_UPDN_SEL, OUT_TYPE, and GPIO_OUT_DIS determine IO type for non-GPIO configuration |
| GPIO_RX_ID  | 4:0  | GPIO ID for pin while receiving  | 0bXXXXX: This GPIO receive ID   |

**GPIO A (0x2C2)**

## GPIO 6

| BIT         | 7           | 6 | 5           | 4           | 3         | 2           | 1           | 0            |
|-------------|-------------|---|-------------|-------------|-----------|-------------|-------------|--------------|
| Field       | RES_CFG     | – | TX_COMP_EN  | GPIO_OUT    | GPIO_IN   | GPIO_RX_EN  | GPIO_TX_EN  | GPIO_OUT_DIS |
| Reset       | 0b1         | – | 0b0         | 0b0         | 0b0       | 0b0         | 0b1         | 0b1          |
| Access Type | Write, Read | – | Write, Read | Write, Read | Read Only | Write, Read | Write, Read | Write, Read  |

| BITFIELD     | BITS | DESCRIPTION   | DECODE  |
|--------------|------|---|---|
| RES_CFG      | 7    | Pull-Up/Pull-Down Resistor Strength   | 0b0: 40kΩ<br>0b1: 1MΩ   |
| TX_COMP_EN   | 5    | Enables jitter minimization compensation  | 0b0: Jitter compensation disabled<br>0b1: Jitter compensation enabled                                       |
| GPIO_OUT     | 4    | GPIO pin output drive value when GPIO_RX_EN = 0. This can be used to drive a value out on an MFP.   | 0b0: This GPIO pin output is driven to 0<br>0b1: This GPIO pin output is driven to 1                        |
| GPIO_IN      | 3    | GPIO pin local MFP input level  | 0b0: This GPIO pin value is 0<br>0b1: This GPIO pin value is 1  |
| GPIO_RX_EN   | 2    | GPIO out source control.<br>Set to 1 to receive GPIO value from GMSL link. Set GPIO_OUT_DIS to 0 to output the received value on the local MFP. | 0b0: This GPIO source disabled for GMSL reception<br>0b1: This GPIO source enabled for GMSL reception       |
| GPIO_TX_EN   | 1    | GPIO Tx source control.<br>Set to 1 to transmit the local MFP input value across the GMSL link.   | 0b0: This GPIO source disabled for GMSL transmission<br>0b1: This GPIO source enabled for GMSL transmission |
| GPIO_OUT_DIS | 0    | Disables GPIO output driver   | 0b0: Output driver enabled<br>0b1: Output driver disabled   |

**GPIO B (0x2C3)**

## GPIO 6

| BIT         | 7                  | 6 | 5           | 4               | 3 | 2 | 1 | 0 |
|-------------|--------------------|---|-------------|-----------------|---|---|---|---|
| Field       | PULL_UPDN_SEL[1:0] |   | OUT_TYPE    | GPIO_TX_ID[4:0] |   |   |   |   |
| Reset       | 0b10               |   | 0b1         | 0b00110         |   |   |   |   |
| Access Type | Write, Read        |   | Write, Read | Write, Read     |   |   |   |   |

| BITFIELD      | BITS | DESCRIPTION                            | DECODE   |
|---------------|------|--|--|
| PULL_UPDN_SEL | 7:6  | Buffer Pull-Up/Pull-Down Configuration | 0b00: None<br>0b01: Pull-up<br>0b10: Pull-down<br>0b11: Reserved |
| OUT_TYPE      | 5    | Driver type selection                  | 0b0: Open-drain<br>0b1: Push-pull                                |
| GPIO_TX_ID    | 4:0  | GPIO ID for pin while transmitting     | 0bXXXXX: This GPIO transmit ID                                   |

### GPIO C (0x2C4)

#### GPIO 6

| BIT         | 7           | 6 | 5 | 4               | 3 | 2 | 1 | 0 |
|-------------|-------------|---|---|-----------------|---|---|---|---|
| Field       | OVR_RES_CFG | – | – | GPIO_RX_ID[4:0] |   |   |   |   |
| Reset       | 0b0         | – | – | 0b00110         |   |   |   |   |
| Access Type | Write, Read | – | – | Write, Read     |   |   |   |   |

| BITFIELD    | BITS | DESCRIPTION  | DECODE  |
|-------------|------|--|---|
| OVR_RES_CFG | 7    | Override non-GPIO port function IO setting.<br><br>When set, RES_CFG, PULL_UPDN_SEL, OUT_TYPE, and GPIO_OUT_DIS are effective when pin is configured as non-GPIO.<br><br>When cleared, non-GPIO pin function determines IO type. | 0b0: Non-GPIO function determines IO type when alternate function is selected<br>0b1: RES_CFG, PULL_UPDN_SEL, OUT_TYPE, and GPIO_OUT_DIS determine IO type for non-GPIO configuration |
| GPIO_RX_ID  | 4:0  | GPIO ID for pin while receiving  | 0bXXXXX: This GPIO receive ID   |

### GPIO A (0x2C5)

#### GPIO 7

| BIT         | 7           | 6 | 5           | 4           | 3         | 2           | 1           | 0            |
|-------------|-------------|---|-------------|-------------|-----------|-------------|-------------|--------------|
| Field       | RES_CFG     | – | TX_COMP_EN  | GPIO_OUT    | GPIO_IN   | GPIO_RX_EN  | GPIO_TX_EN  | GPIO_OUT_DIS |
| Reset       | 0b1         | – | 0b0         | 0b0         | 0b0       | 0b0         | 0b0         | 0b1          |
| Access Type | Write, Read | – | Write, Read | Write, Read | Read Only | Write, Read | Write, Read | Write, Read  |

| BITFIELD   | BITS | DESCRIPTION   | DECODE   |
|------------|------|---|--|
| RES_CFG    | 7    | Pull-Up/Pull-Down Resistor Strength   | 0b0: 40kΩ<br>0b1: 1MΩ  |
| TX_COMP_EN | 5    | Enables jitter minimization compensation  | 0b0: Jitter compensation disabled<br>0b1: Jitter compensation enabled                |
| GPIO_OUT   | 4    | GPIO pin output drive value when GPIO_RX_EN = 0. This can be used to drive a value out on an MFP. | 0b0: This GPIO pin output is driven to 0<br>0b1: This GPIO pin output is driven to 1 |

| BITFIELD     | BITS | DESCRIPTION   | DECODE  |
|--------------|------|---|---|
| GPIO_IN      | 3    | GPIO pin local MFP input level  | 0b0: This GPIO pin value is 0<br>0b1: This GPIO pin value is 1  |
| GPIO_RX_EN   | 2    | GPIO out source control.<br>Set to 1 to receive GPIO value from GMSL link. Set GPIO_OUT_DIS to 0 to output the received value on the local MFP. | 0b0: This GPIO source disabled for GMSL reception<br>0b1: This GPIO source enabled for GMSL reception       |
| GPIO_TX_EN   | 1    | GPIO Tx source control.<br>Set to 1 to transmit the local MFP input value across the GMSL link.   | 0b0: This GPIO source disabled for GMSL transmission<br>0b1: This GPIO source enabled for GMSL transmission |
| GPIO_OUT_DIS | 0    | Disables GPIO output driver   | 0b0: Output driver enabled<br>0b1: Output driver disabled   |

**GPIO B (0x2C6)**

## GPIO 7

| BIT         | 7                  | 6 | 5           | 4               | 3 | 2 | 1 | 0 |
|-------------|--------------------|---|-------------|-----------------|---|---|---|---|
| Field       | PULL_UPDN_SEL[1:0] |   | OUT_TYPE    | GPIO_TX_ID[4:0] |   |   |   |   |
| Reset       | 0b10               |   | 0b1         | 0b00111         |   |   |   |   |
| Access Type | Write, Read        |   | Write, Read | Write, Read     |   |   |   |   |

| BITFIELD      | BITS | DESCRIPTION                            | DECODE   |
|---------------|------|--|--|
| PULL_UPDN_SEL | 7:6  | Buffer Pull-Up/Pull-Down Configuration | 0b00: None<br>0b01: Pull-up<br>0b10: Pull-down<br>0b11: Reserved |
| OUT_TYPE      | 5    | Driver type selection                  | 0b0: Open-drain<br>0b1: Push-pull                                |
| GPIO_TX_ID    | 4:0  | GPIO ID for pin while transmitting     | 0bXXXXX: This GPIO transmit ID                                   |

**GPIO C (0x2C7)**

## GPIO 7

| BIT         | 7           | 6 | 5 | 4               | 3 | 2 | 1 | 0 |
|-------------|-------------|---|---|-----------------|---|---|---|---|
| Field       | OVR_RES_CFG | – | – | GPIO_RX_ID[4:0] |   |   |   |   |
| Reset       | 0b0         | – | – | 0b00111         |   |   |   |   |
| Access Type | Write, Read | – | – | Write, Read     |   |   |   |   |

| BITFIELD    | BITS | DESCRIPTION   | DECODE  |
|-------------|------|---|---|
| OVR_RES_CFG | 7    | Override non-GPIO port function IO setting.<br><br>When set, RES_CFG, PULL_UPDN_SEL, OUT_TYPE, and GPIO_OUT_DIS are effective when pin is configured as non-GPIO. | 0b0: Non-GPIO function determines IO type when alternate function is selected<br>0b1: RES_CFG, PULL_UPDN_SEL, OUT_TYPE, and GPIO_OUT_DIS determine IO type for non-GPIO configuration |

| BITFIELD   | BITS | DESCRIPTION   | DECODE                        |
|------------|------|---|-------------------------------|
|            |      | When cleared, non-GPIO pin function determines IO type. |                               |
| GPIO_RX_ID | 4:0  | GPIO ID for pin while receiving                         | 0bXXXXX: This GPIO receive ID |

**GPIO A (0x2C8)**

## GPIO 8

| BIT         | 7           | 6 | 5           | 4           | 3         | 2           | 1           | 0            |
|-------------|-------------|---|-------------|-------------|-----------|-------------|-------------|--------------|
| Field       | RES_CFG     | – | TX_COMP_EN  | GPIO_OUT    | GPIO_IN   | GPIO_RX_EN  | GPIO_TX_EN  | GPIO_OUT_DIS |
| Reset       | 0b1         | – | 0b0         | 0b0         | 0b0       | 0b0         | 0b0         | 0b1          |
| Access Type | Write, Read | – | Write, Read | Write, Read | Read Only | Write, Read | Write, Read | Write, Read  |

| BITFIELD     | BITS | DESCRIPTION  | DECODE  |
|--------------|------|--|---|
| RES_CFG      | 7    | Pull-Up/Pull-Down Resistor Strength  | 0b0: 40kΩ<br>0b1: 1MΩ   |
| TX_COMP_EN   | 5    | Enables jitter minimization compensation   | 0b0: Jitter compensation disabled<br>0b1: Jitter compensation enabled                                       |
| GPIO_OUT     | 4    | GPIO pin output drive value when GPIO_RX_EN = 0. This can be used to drive a value out on an MFP.  | 0b0: This GPIO pin output is driven to 0<br>0b1: This GPIO pin output is driven to 1                        |
| GPIO_IN      | 3    | GPIO pin local MFP input level   | 0b0: This GPIO pin value is 0<br>0b1: This GPIO pin value is 1  |
| GPIO_RX_EN   | 2    | GPIO out source control. Set to 1 to receive GPIO value from GMSL link. Set GPIO_OUT_DIS to 0 to output the received value on the local MFP. | 0b0: This GPIO source disabled for GMSL reception<br>0b1: This GPIO source enabled for GMSL reception       |
| GPIO_TX_EN   | 1    | GPIO Tx source control. Set to 1 to transmit the local MFP input value across the GMSL link.   | 0b0: This GPIO source disabled for GMSL transmission<br>0b1: This GPIO source enabled for GMSL transmission |
| GPIO_OUT_DIS | 0    | Disables GPIO output driver  | 0b0: Output driver enabled<br>0b1: Output driver disabled   |

**GPIO B (0x2C9)**

## GPIO 8

| BIT         | 7                  | 6 | 5           | 4               | 3 | 2 | 1 | 0 |
|-------------|--------------------|---|-------------|-----------------|---|---|---|---|
| Field       | PULL_UPDN_SEL[1:0] |   | OUT_TYPE    | GPIO_TX_ID[4:0] |   |   |   |   |
| Reset       | 0b10               |   | 0b1         | 0b01000         |   |   |   |   |
| Access Type | Write, Read        |   | Write, Read | Write, Read     |   |   |   |   |

| BITFIELD      | BITS | DESCRIPTION                            | DECODE                      |
|---------------|------|--|-----------------------------|
| PULL_UPDN_SEL | 7:6  | Buffer Pull-Up/Pull-Down Configuration | 0b00: None<br>0b01: Pull-up |

| BITFIELD   | BITS | DESCRIPTION                        | DECODE                            |
|------------|------|------------------------------------|-----------------------------------|
|            |      |                                    | 0b10: Pull-down<br>0b11: Reserved |
| OUT_TYPE   | 5    | Driver type selection              | 0b0: Open-drain<br>0b1: Push-pull |
| GPIO_TX_ID | 4:0  | GPIO ID for pin while transmitting | 0bXXXXX: This GPIO transmit ID    |

**GPIO C (0x2CA)**

## GPIO 8

| BIT         | 7           | 6 | 5 | 4               | 3 | 2 | 1 | 0 |
|-------------|-------------|---|---|-----------------|---|---|---|---|
| Field       | OVR_RES_CFG | – | – | GPIO_RX_ID[4:0] |   |   |   |   |
| Reset       | 0b0         | – | – | 0b01000         |   |   |   |   |
| Access Type | Write, Read | – | – | Write, Read     |   |   |   |   |

| BITFIELD    | BITS | DESCRIPTION  | DECODE  |
|-------------|------|--|---|
| OVR_RES_CFG | 7    | Override non-GPIO port function IO setting.<br><br>When set, RES_CFG, PULL_UPDN_SEL, OUT_TYPE, and GPIO_OUT_DIS are effective when pin is configured as non-GPIO.<br><br>When cleared, non-GPIO pin function determines IO type. | 0b0: Non-GPIO function determines IO type when alternate function is selected<br>0b1: RES_CFG, PULL_UPDN_SEL, OUT_TYPE, and GPIO_OUT_DIS determine IO type for non-GPIO configuration |
| GPIO_RX_ID  | 4:0  | GPIO ID for pin while receiving  | 0bXXXXX: This GPIO receive ID   |

**GPIO A (0x2CB)**

## GPIO 9

| BIT         | 7           | 6 | 5           | 4           | 3         | 2           | 1           | 0            |
|-------------|-------------|---|-------------|-------------|-----------|-------------|-------------|--------------|
| Field       | RES_CFG     | – | TX_COMP_EN  | GPIO_OUT    | GPIO_IN   | GPIO_RX_EN  | GPIO_TX_EN  | GPIO_OUT_DIS |
| Reset       | 0b1         | – | 0b0         | 0b0         | 0b0       | 0b0         | 0b0         | 0b1          |
| Access Type | Write, Read | – | Write, Read | Write, Read | Read Only | Write, Read | Write, Read | Write, Read  |

| BITFIELD   | BITS | DESCRIPTION   | DECODE   |
|------------|------|---|--|
| RES_CFG    | 7    | Pull-Up/Pull-Down Resistor Strength   | 0b0: 40kΩ<br>0b1: 1MΩ  |
| TX_COMP_EN | 5    | Enables jitter minimization compensation  | 0b0: Jitter compensation disabled<br>0b1: Jitter compensation enabled                |
| GPIO_OUT   | 4    | GPIO pin output drive value when GPIO_RX_EN = 0. This can be used to drive a value out on an MFP. | 0b0: This GPIO pin output is driven to 0<br>0b1: This GPIO pin output is driven to 1 |
| GPIO_IN    | 3    | GPIO pin local MFP input level  | 0b0: This GPIO pin value is 0<br>0b1: This GPIO pin value is 1                       |

| BITFIELD     | BITS | DESCRIPTION   | DECODE  |
|--------------|------|---|---|
| GPIO_RX_EN   | 2    | GPIO out source control.<br>Set to 1 to receive GPIO value from GMSL link. Set GPIO_OUT_DIS to 0 to output the received value on the local MFP. | 0b0: This GPIO source disabled for GMSL reception<br>0b1: This GPIO source enabled for GMSL reception       |
| GPIO_TX_EN   | 1    | GPIO Tx source control.<br>Set to 1 to transmit the local MFP input value across the GMSL link.   | 0b0: This GPIO source disabled for GMSL transmission<br>0b1: This GPIO source enabled for GMSL transmission |
| GPIO_OUT_DIS | 0    | Disables GPIO output driver   | 0b0: Output driver enabled<br>0b1: Output driver disabled   |

**GPIO B (0x2CC)**

## GPIO 9

| BIT         | 7                  | 6 | 5           | 4               | 3 | 2 | 1 | 0 |
|-------------|--------------------|---|-------------|-----------------|---|---|---|---|
| Field       | PULL_UPDN_SEL[1:0] |   | OUT_TYPE    | GPIO_TX_ID[4:0] |   |   |   |   |
| Reset       | 0b10               |   | 0b1         | 0b01001         |   |   |   |   |
| Access Type | Write, Read        |   | Write, Read | Write, Read     |   |   |   |   |

| BITFIELD      | BITS | DESCRIPTION                            | DECODE   |
|---------------|------|--|--|
| PULL_UPDN_SEL | 7:6  | Buffer Pull-Up/Pull-Down Configuration | 0b00: None<br>0b01: Pull-up<br>0b10: Pull-down<br>0b11: Reserved |
| OUT_TYPE      | 5    | Driver type selection                  | 0b0: Open-drain<br>0b1: Push-pull                                |
| GPIO_TX_ID    | 4:0  | GPIO ID for pin while transmitting     | 0bXXXXX: This GPIO transmit ID                                   |

**GPIO C (0x2CD)**

## GPIO 9

| BIT         | 7           | 6 | 5 | 4               | 3 | 2 | 1 | 0 |
|-------------|-------------|---|---|-----------------|---|---|---|---|
| Field       | OVR_RES_CFG | – | – | GPIO_RX_ID[4:0] |   |   |   |   |
| Reset       | 0b0         | – | – | 0b01001         |   |   |   |   |
| Access Type | Write, Read | – | – | Write, Read     |   |   |   |   |

| BITFIELD    | BITS | DESCRIPTION  | DECODE  |
|-------------|------|--|---|
| OVR_RES_CFG | 7    | Override non-GPIO port function IO setting.<br><br>When set, RES_CFG, PULL_UPDN_SEL, OUT_TYPE, and GPIO_OUT_DIS are effective when pin is configured as non-GPIO.<br><br>When cleared, non-GPIO pin function determines IO type. | 0b0: Non-GPIO function determines IO type when alternate function is selected<br>0b1: RES_CFG, PULL_UPDN_SEL, OUT_TYPE, and GPIO_OUT_DIS determine IO type for non-GPIO configuration |

| BITFIELD   | BITS | DESCRIPTION                     | DECODE                        |
|------------|------|---------------------------------|-------------------------------|
| GPIO_RX_ID | 4:0  | GPIO ID for pin while receiving | 0bXXXXX: This GPIO receive ID |

**GPIO A (0x2CE)**

## GPIO 10

| BIT         | 7           | 6 | 5           | 4           | 3         | 2           | 1           | 0            |
|-------------|-------------|---|-------------|-------------|-----------|-------------|-------------|--------------|
| Field       | RES_CFG     | – | TX_COMP_EN  | GPIO_OUT    | GPIO_IN   | GPIO_RX_EN  | GPIO_TX_EN  | GPIO_OUT_DIS |
| Reset       | 0b1         | – | 0b0         | 0b0         | 0b0       | 0b0         | 0b0         | 0b1          |
| Access Type | Write, Read | – | Write, Read | Write, Read | Read Only | Write, Read | Write, Read | Write, Read  |

| BITFIELD     | BITS | DESCRIPTION   | DECODE  |
|--------------|------|---|---|
| RES_CFG      | 7    | Pull-Up/Pull-Down Resistor Strength   | 0b0: 40kΩ<br>0b1: 1MΩ   |
| TX_COMP_EN   | 5    | Enables jitter minimization compensation  | 0b0: Jitter compensation disabled<br>0b1: Jitter compensation enabled                                       |
| GPIO_OUT     | 4    | GPIO pin output drive value when GPIO_RX_EN = 0. This can be used to drive a value out on an MFP.   | 0b0: This GPIO pin output is driven to 0<br>0b1: This GPIO pin output is driven to 1                        |
| GPIO_IN      | 3    | GPIO pin local MFP input level  | 0b0: This GPIO pin value is 0<br>0b1: This GPIO pin value is 1  |
| GPIO_RX_EN   | 2    | GPIO out source control.<br>Set to 1 to receive GPIO value from GMSL link. Set GPIO_OUT_DIS to 0 to output the received value on the local MFP. | 0b0: This GPIO source disabled for GMSL reception<br>0b1: This GPIO source enabled for GMSL reception       |
| GPIO_TX_EN   | 1    | GPIO Tx source control.<br>Set to 1 to transmit the local MFP input value across the GMSL link.   | 0b0: This GPIO source disabled for GMSL transmission<br>0b1: This GPIO source enabled for GMSL transmission |
| GPIO_OUT_DIS | 0    | Disables GPIO output driver   | 0b0: Output driver enabled<br>0b1: Output driver disabled   |

**GPIO B (0x2CF)**

## GPIO 10

| BIT         | 7                  | 6 | 5           | 4               | 3 | 2 | 1 | 0 |
|-------------|--------------------|---|-------------|-----------------|---|---|---|---|
| Field       | PULL_UPDN_SEL[1:0] |   | OUT_TYPE    | GPIO_TX_ID[4:0] |   |   |   |   |
| Reset       | 0b10               |   | 0b1         | 0b01010         |   |   |   |   |
| Access Type | Write, Read        |   | Write, Read | Write, Read     |   |   |   |   |

| BITFIELD      | BITS | DESCRIPTION                            | DECODE   |
|---------------|------|--|--|
| PULL_UPDN_SEL | 7:6  | Buffer Pull-Up/Pull-Down Configuration | 0b00: None<br>0b01: Pull-up<br>0b10: Pull-down<br>0b11: Reserved |

| BITFIELD   | BITS | DESCRIPTION                        | DECODE                            |
|------------|------|------------------------------------|-----------------------------------|
| OUT_TYPE   | 5    | Driver type selection              | 0b0: Open-drain<br>0b1: Push-pull |
| GPIO_TX_ID | 4:0  | GPIO ID for pin while transmitting | 0bXXXXX: This GPIO transmit ID    |

**GPIO C (0x2D0)**

## GPIO 10

| BIT         | 7           | 6 | 5 | 4               | 3 | 2 | 1 | 0 |
|-------------|-------------|---|---|-----------------|---|---|---|---|
| Field       | OVR_RES_CFG | – | – | GPIO_RX_ID[4:0] |   |   |   |   |
| Reset       | 0b0         | – | – | 0b01010         |   |   |   |   |
| Access Type | Write, Read | – | – | Write, Read     |   |   |   |   |

| BITFIELD    | BITS | DESCRIPTION  | DECODE  |
|-------------|------|--|---|
| OVR_RES_CFG | 7    | Override non-GPIO port function IO setting.<br><br>When set, RES_CFG, PULL_UPDN_SEL, OUT_TYPE, and GPIO_OUT_DIS are effective when pin is configured as non-GPIO.<br><br>When cleared, non-GPIO pin function determines IO type. | 0b0: Non-GPIO function determines IO type when alternate function is selected<br>0b1: RES_CFG, PULL_UPDN_SEL, OUT_TYPE, and GPIO_OUT_DIS determine IO type for non-GPIO configuration |
| GPIO_RX_ID  | 4:0  | GPIO ID for pin while receiving  | 0bXXXXX: This GPIO receive ID   |

**GPIO A (0x2D1)**

## GPIO 11

| BIT         | 7           | 6 | 5           | 4           | 3         | 2           | 1           | 0            |
|-------------|-------------|---|-------------|-------------|-----------|-------------|-------------|--------------|
| Field       | RES_CFG     | – | TX_COMP_EN  | GPIO_OUT    | GPIO_IN   | GPIO_RX_EN  | GPIO_TX_EN  | GPIO_OUT_DIS |
| Reset       | 0b1         | – | 0b0         | 0b0         | 0b0       | 0b0         | 0b0         | 0b1          |
| Access Type | Write, Read | – | Write, Read | Write, Read | Read Only | Write, Read | Write, Read | Write, Read  |

| BITFIELD   | BITS | DESCRIPTION   | DECODE  |
|------------|------|---|---|
| RES_CFG    | 7    | Pull-Up/Pull-Down Resistor Strength   | 0b0: 40kΩ<br>0b1: 1MΩ   |
| TX_COMP_EN | 5    | Enables jitter minimization compensation  | 0b0: Jitter compensation disabled<br>0b1: Jitter compensation enabled                                 |
| GPIO_OUT   | 4    | GPIO pin output drive value when GPIO_RX_EN = 0. This can be used to drive a value out on an MFP. | 0b0: This GPIO pin output is driven to 0<br>0b1: This GPIO pin output is driven to 1                  |
| GPIO_IN    | 3    | GPIO pin local MFP input level  | 0b0: This GPIO pin value is 0<br>0b1: This GPIO pin value is 1  |
| GPIO_RX_EN | 2    | GPIO out source control.<br>Set to 1 to receive GPIO value from GMSL link. Set                    | 0b0: This GPIO source disabled for GMSL reception<br>0b1: This GPIO source enabled for GMSL reception |

| BITFIELD     | BITS | DESCRIPTION   | DECODE  |
|--------------|------|---|---|
|              |      | GPIO_OUT_DIS to 0 to output the received value on the local MFP.                                |   |
| GPIO_TX_EN   | 1    | GPIO Tx source control.<br>Set to 1 to transmit the local MFP input value across the GMSL link. | 0b0: This GPIO source disabled for GMSL transmission<br>0b1: This GPIO source enabled for GMSL transmission |
| GPIO_OUT_DIS | 0    | Disables GPIO output driver   | 0b0: Output driver enabled<br>0b1: Output driver disabled   |

**GPIO B (0x2D2)**

## GPIO 11

| BIT         | 7                  | 6 | 5           | 4               | 3 | 2 | 1 | 0 |
|-------------|--------------------|---|-------------|-----------------|---|---|---|---|
| Field       | PULL_UPDN_SEL[1:0] |   | OUT_TYPE    | GPIO_TX_ID[4:0] |   |   |   |   |
| Reset       | 0b10               |   | 0b1         | 0b01011         |   |   |   |   |
| Access Type | Write, Read        |   | Write, Read | Write, Read     |   |   |   |   |

| BITFIELD      | BITS | DESCRIPTION                            | DECODE   |
|---------------|------|--|--|
| PULL_UPDN_SEL | 7:6  | Buffer Pull-Up/Pull-Down Configuration | 0b00: None<br>0b01: Pull-up<br>0b10: Pull-down<br>0b11: Reserved |
| OUT_TYPE      | 5    | Driver type selection                  | 0b0: Open-drain<br>0b1: Open-drain                               |
| GPIO_TX_ID    | 4:0  | GPIO ID for pin while transmitting     | 0bXXXXX: This GPIO transmit ID                                   |

**GPIO C (0x2D3)**

## GPIO 11

| BIT         | 7           | 6 | 5 | 4               | 3 | 2 | 1 | 0 |
|-------------|-------------|---|---|-----------------|---|---|---|---|
| Field       | OVR_RES_CFG | – | – | GPIO_RX_ID[4:0] |   |   |   |   |
| Reset       | 0b0         | – | – | 0b01011         |   |   |   |   |
| Access Type | Write, Read | – | – | Write, Read     |   |   |   |   |

| BITFIELD    | BITS | DESCRIPTION  | DECODE  |
|-------------|------|--|---|
| OVR_RES_CFG | 7    | Override non-GPIO port function IO setting.<br><br>When set, RES_CFG, PULL_UPDN_SEL, OUT_TYPE, and GPIO_OUT_DIS are effective when pin is configured as non-GPIO.<br><br>When cleared, non-GPIO pin function determines IO type. | 0b0: Non-GPIO function determines IO type when alternate function is selected<br>0b1: RES_CFG, PULL_UPDN_SEL, OUT_TYPE, and GPIO_OUT_DIS determine IO type for non-GPIO configuration |
| GPIO_RX_ID  | 4:0  | GPIO ID for pin while receiving  | 0bXXXXX: This GPIO receive ID   |

**GPIO A (0x2D4)**

## GPIO 12

| BIT         | 7           | 6 | 5           | 4           | 3         | 2           | 1           | 0            |
|-------------|-------------|---|-------------|-------------|-----------|-------------|-------------|--------------|
| Field       | RES_CFG     | – | TX_COMP_EN  | GPIO_OUT    | GPIO_IN   | GPIO_RX_EN  | GPIO_TX_EN  | GPIO_OUT_DIS |
| Reset       | 0b1         | – | 0b0         | 0b0         | 0b0       | 0b0         | 0b0         | 0b1          |
| Access Type | Write, Read | – | Write, Read | Write, Read | Read Only | Write, Read | Write, Read | Write, Read  |

| BITFIELD     | BITS | DESCRIPTION   | DECODE  |
|--------------|------|---|---|
| RES_CFG      | 7    | Pull-Up/Pull-Down Resistor Strength   | 0b0: 40kΩ<br>0b1: 1MΩ   |
| TX_COMP_EN   | 5    | Enables jitter minimization compensation  | 0b0: Jitter compensation disabled<br>0b1: Jitter compensation enabled                                       |
| GPIO_OUT     | 4    | GPIO pin output drive value when GPIO_RX_EN = 0. This can be used to drive a value out on an MFP.   | 0b0: This GPIO pin output is driven to 0<br>0b1: This GPIO pin output is driven to 1                        |
| GPIO_IN      | 3    | GPIO pin local MFP input level  | 0b0: This GPIO pin value is 0<br>0b1: This GPIO pin value is 1  |
| GPIO_RX_EN   | 2    | GPIO out source control.<br>Set to 1 to receive GPIO value from GMSL link. Set GPIO_OUT_DIS to 0 to output the received value on the local MFP. | 0b0: This GPIO source disabled for GMSL reception<br>0b1: This GPIO source enabled for GMSL reception       |
| GPIO_TX_EN   | 1    | GPIO Tx source control.<br>Set to 1 to transmit the local MFP input value across the GMSL link.   | 0b0: This GPIO source disabled for GMSL transmission<br>0b1: This GPIO source enabled for GMSL transmission |
| GPIO_OUT_DIS | 0    | Disables GPIO output driver   | 0b0: Output driver enabled<br>0b1: Output driver disabled   |

**GPIO B (0x2D5)**

## GPIO 12

| BIT         | 7                  | 6 | 5           | 4               | 3 | 2 | 1 | 0 |
|-------------|--------------------|---|-------------|-----------------|---|---|---|---|
| Field       | PULL_UPDN_SEL[1:0] |   | OUT_TYPE    | GPIO_TX_ID[4:0] |   |   |   |   |
| Reset       | 0b10               |   | 0b1         | 0b01100         |   |   |   |   |
| Access Type | Write, Read        |   | Write, Read | Write, Read     |   |   |   |   |

| BITFIELD      | BITS | DESCRIPTION                            | DECODE   |
|---------------|------|--|--|
| PULL_UPDN_SEL | 7:6  | Buffer Pull-Up/Pull-Down Configuration | 0b00: None<br>0b01: Pull-up<br>0b10: Pull-down<br>0b11: Reserved |
| OUT_TYPE      | 5    | Driver type selection                  | 0b0: Open-drain<br>0b1: Open-drain                               |
| GPIO_TX_ID    | 4:0  | GPIO ID for pin while transmitting     | 0bXXXXX: This GPIO transmit ID                                   |

**GPIO C (0x2D6)**

GPIO 12

| BIT         | 7           | 6 | 5 | 4               | 3 | 2 | 1 | 0 |
|-------------|-------------|---|---|-----------------|---|---|---|---|
| Field       | OVR_RES_CFG | – | – | GPIO_RX_ID[4:0] |   |   |   |   |
| Reset       | 0b0         | – | – | 0b01100         |   |   |   |   |
| Access Type | Write, Read | – | – | Write, Read     |   |   |   |   |

| BITFIELD    | BITS | DESCRIPTION  | DECODE  |
|-------------|------|--|---|
| OVR_RES_CFG | 7    | Override non-GPIO port function IO setting.<br><br>When set, RES_CFG, PULL_UPDN_SEL, OUT_TYPE, and GPIO_OUT_DIS are effective when pin is configured as non-GPIO.<br><br>When cleared, non-GPIO pin function determines IO type. | 0b0: Non-GPIO function determines IO type when alternate function is selected<br>0b1: RES_CFG, PULL_UPDN_SEL, OUT_TYPE, and GPIO_OUT_DIS determine IO type for non-GPIO configuration |
| GPIO_RX_ID  | 4:0  | GPIO ID for pin while receiving  | 0bXXXXX: This GPIO receive ID   |

**CMU2 (0x302)**

| BIT         | 7 | 6                  | 5 | 4 | 3 | 2 | 1 | 0 |
|-------------|---|--------------------|---|---|---|---|---|---|
| Field       | – | PFDDIV_RSHORT[2:0] |   |   | – | – | – | – |
| Reset       | – | 0b000              |   |   | – | – | – | – |
| Access Type | – | Write, Read        |   |   | – | – | – | – |

| BITFIELD      | BITS | DESCRIPTION   | DECODE   |
|---------------|------|---|--|
| PFDDIV_RSHORT | 6:4  | PFDDIV regulator voltage control. Controls the supply voltage to the 6GHz clock generation PLL phase detector and dividers. | 0: VREG_PFDDIV = 1.0V<br>1: VREG_PFDDIV = 1.1V<br>2: VREG_PFDDIV = 0.875V<br>3: VREG_PFDDIV = 0.94V<br>4: VREG_PFDDIV = 1.0V<br>5: VREG_PFDDIV = 1.1V<br>6: VREG_PFDDIV = 0.875V<br>7: VREG_PFDDIV = 0.94V |

**BACKTOP1 (0x308)**

| BIT   | 7            | 6            | 5            | 4            | 3         | 2 | 1 | 0          |
|-------|--------------|--------------|--------------|--------------|-----------|---|---|------------|
| Field | CSIPLLU_LOCK | CSIPLLZ_LOCK | CSIPLLY_LOCK | CSIPLLX_LOCK | LINE_SPL2 | – | – | BACKTOP_EN |
| Reset | 0b0          | 0b0          | 0b0          | 0b0          | 0b0       | – | – | 0b1        |

|                    |           |           |           |           |             |   |   |             |
|--------------------|-----------|-----------|-----------|-----------|-------------|---|---|-------------|
| <b>Access Type</b> | Read Only | Read Only | Read Only | Read Only | Write, Read | – | – | Write, Read |
|--------------------|-----------|-----------|-----------|-----------|-------------|---|---|-------------|

| BITFIELD     | BITS | DESCRIPTION   | DECODE  |
|--------------|------|---|---|
| CSIPLLU_LOCK | 7    | CSI MIPI TX PLL 3 locked (PLL for MIPI Port F in 4x2 mode)  | 0b0: CSI2 PLL 3 not locked<br>0b1: CSI2 PLL 3 locked  |
| CSIPLLZ_LOCK | 6    | CSI MIPI TX PLL 2 locked (PLL for MIPI Port B in 2x4 mode, Port E in 4x2 mode)  | 0b0: CSI2 PLL 2 not locked<br>0b1: CSI2 PLL 2 locked  |
| CSIPLLY_LOCK | 5    | CSI MIPI TX PLL 1 locked (PLL for MIPI Port A in 2x4 mode, Port D in 4x2 mode)  | 0b0: CSI2 PLL 1 not locked<br>0b1: CSI2 PLL 1 locked  |
| CSIPLLX_LOCK | 4    | CSI MIPI TX PLL 0 locked (PLL for MIPI Port C in 4x2 mode)  | 0b0: CSI2 PLL 0 not locked<br>0b1: CSI2 PLL 0 locked  |
| LINE_SPL2    | 3    | Line based distribution to line memories for Video Pipeline Z. When set, even-numbered video lines are stored in one-line buffer memory array, odd lines are stored in another. | 0b0: Disable line-based distribution to line memories for Video Pipeline Z<br>0b1: Enable line-based distribution to line memories for Video Pipeline Z |
| BACKTOP_EN   | 0    | Backtop (line-buffer memory) write logic enable. Setting to 0 stops data output from the MIPI transmitter.  | 0b0: Disable writes to BACKTOP (line buffer) memories<br>0b1: Enable writes to BACKTOP (line buffer) memories   |

**BACKTOP4 (0x30B)**

|                    |               |          |          |          |          |          |          |          |
|--------------------|---------------|----------|----------|----------|----------|----------|----------|----------|
| <b>BIT</b>         | <b>7</b>      | <b>6</b> | <b>5</b> | <b>4</b> | <b>3</b> | <b>2</b> | <b>1</b> | <b>0</b> |
| <b>Field</b>       | VS_VC2_L[7:0] |          |          |          |          |          |          |          |
| <b>Reset</b>       | 0x00          |          |          |          |          |          |          |          |
| <b>Access Type</b> | Write, Read   |          |          |          |          |          |          |          |

| BITFIELD | BITS | DESCRIPTION  | DECODE  |
|----------|------|--|---|
| VS_VC2_L | 7:0  | For each video frame, override whether Frame Start-End short packets are sent out for each VC. Pipe Y/MIPI output A.<br><br>When register is set to 0, there is no override. When not set to 0, each of the 16 bits enables Frame Start-End short packets for virtual channels 0-15. For example bit 0 set to 1 enables packets for VC0, bit 1 enables packets for VC1, etc. | 0bXXXXXXXX1: Override to enable packets for VC0<br>0bXXXXXXXX1X: Override to enable packets for VC1<br>0bXXXXXXXX1XX: Override to enable packets for VC2 etc... |

**BACKTOP5 (0x30C)**

|                    |               |          |          |          |          |          |          |          |
|--------------------|---------------|----------|----------|----------|----------|----------|----------|----------|
| <b>BIT</b>         | <b>7</b>      | <b>6</b> | <b>5</b> | <b>4</b> | <b>3</b> | <b>2</b> | <b>1</b> | <b>0</b> |
| <b>Field</b>       | VS_VC2_H[7:0] |          |          |          |          |          |          |          |
| <b>Reset</b>       | 0x00          |          |          |          |          |          |          |          |
| <b>Access Type</b> | Write, Read   |          |          |          |          |          |          |          |

| <b>BITFIELD</b> | <b>BITS</b> | <b>DESCRIPTION</b>  | <b>DECODE</b>  |
|-----------------|-------------|---|--|
| VS_VC2_H        | 7:0         | <p>For each video frame, override whether Frame Start-End short packets are sent out for each VC. Pipe Y/MIPI output A.</p> <p>When register is set to 0, there is no override. When not set to 0, each of the 16 bits enables Frame Start-End short packets for virtual channels 0-15. For example bit 0 set to 1 enables packets for VC0, bit 1 enables packets for VC1, etc.</p> | <p>0bXXXXXXXX1: Override to enable packets for VC8<br/>                     0bXXXXXXXX1X: Override to enable packets for VC9<br/>                     0bXXXXXXXX1XX: Override to enable packets for VC10<br/>                     etc...</p> |

**BACKTOP6 (0x30D)**

|                    |               |          |          |          |          |          |          |          |
|--------------------|---------------|----------|----------|----------|----------|----------|----------|----------|
| <b>BIT</b>         | <b>7</b>      | <b>6</b> | <b>5</b> | <b>4</b> | <b>3</b> | <b>2</b> | <b>1</b> | <b>0</b> |
| <b>Field</b>       | VS_VC3_L[7:0] |          |          |          |          |          |          |          |
| <b>Reset</b>       | 0x00          |          |          |          |          |          |          |          |
| <b>Access Type</b> | Write, Read   |          |          |          |          |          |          |          |

| <b>BITFIELD</b> | <b>BITS</b> | <b>DESCRIPTION</b>  | <b>DECODE</b>   |
|-----------------|-------------|---|---|
| VS_VC3_L        | 7:0         | <p>For each video frame, override whether Frame Start-End short packets are sent out for each VC. Pipe Z/MIPI output B.</p> <p>When register is set to 0, there is no override. When not set to 0, each of the 16 bits enables Frame Start-End short packets for virtual channels 0-15. For example bit 0 set to 1 enables packets for VC0, bit 1 enables packets for VC1, etc.</p> | <p>0bXXXXXXXX1: Override to enable packets for VC0<br/>                     0bXXXXXXXX1X: Override to enable packets for VC1<br/>                     0bXXXXXXXX1XX: Override to enable packets for VC2<br/>                     etc...</p> |

**BACKTOP7 (0x30E)**

|              |               |          |          |          |          |          |          |          |
|--------------|---------------|----------|----------|----------|----------|----------|----------|----------|
| <b>BIT</b>   | <b>7</b>      | <b>6</b> | <b>5</b> | <b>4</b> | <b>3</b> | <b>2</b> | <b>1</b> | <b>0</b> |
| <b>Field</b> | VS_VC3_H[7:0] |          |          |          |          |          |          |          |

|                    |             |
|--------------------|-------------|
| <b>Reset</b>       | 0x00        |
| <b>Access Type</b> | Write, Read |

| <b>BITFIELD</b> | <b>BITS</b> | <b>DESCRIPTION</b>  | <b>DECODE</b>  |
|-----------------|-------------|---|--|
| VS_VC3_H        | 7:0         | <p>For each video frame, override whether Frame Start-End short packets are sent out for each VC. Pipe Z/MIPI output B.</p> <p>When register is set to 0, there is no override. When not set to 0, each of the 16 bits enables Frame Start-End short packets for virtual channels 0-15. For example bit 0 set to 1 enables packets for VC0, bit 1 enables packets for VC1, etc.</p> | <p>0bXXXXXXXX1: Override to enable packets for VC8<br/>                     0bXXXXXXXX1X: Override to enable packets for VC9<br/>                     0bXXXXXXXX1XX: Override to enable packets for VC10<br/>                     etc...</p> |

**BACKTOP11 (0x312)**

| <b>BIT</b>         | <b>7</b> | <b>6</b>      | <b>5</b>      | <b>4</b> | <b>3</b> | <b>2</b>  | <b>1</b>  | <b>0</b> |
|--------------------|----------|---------------|---------------|----------|----------|-----------|-----------|----------|
| <b>Field</b>       | –        | cmd_overflow3 | cmd_overflow2 | –        | –        | LMO_Z     | LMO_Y     | –        |
| <b>Reset</b>       | –        | 0b0           | 0b0           | –        | –        | 0b0       | 0b0       | –        |
| <b>Access Type</b> | –        | Read Only     | Read Only     | –        | –        | Read Only | Read Only | –        |

| <b>BITFIELD</b> | <b>BITS</b> | <b>DESCRIPTION</b>   | <b>DECODE</b>   |
|-----------------|-------------|--|---|
| cmd_overflow3   | 6           | Pipeline Z line memory command FIFO overflow detected. FIFO is for commands sent to MIPI TX to output frame start/end and lines of pixel data. | 0b0: Pipeline Z no line memory command FIFO overflow<br>0b1: Pipeline Z line memory command FIFO overflow |
| cmd_overflow2   | 5           | Pipeline Y line memory command FIFO overflow detected. FIFO is for commands sent to MIPI TX to output frame start/end and lines of pixel data. | 0b0: Pipeline Y no line memory command FIFO overflow<br>0b1: Pipeline Y line memory command FIFO overflow |
| LMO_Z           | 2           | Pipeline Z line memory overflow sticky register  | 0b0: Pipeline Z no line memory overflow<br>0b1: Pipeline Z line memory overflow                           |
| LMO_Y           | 1           | Pipeline Y line memory overflow sticky register  | 0b0: Pipeline Y no line memory overflow<br>0b1: Pipeline Y line memory overflow                           |

**BACKTOP12 (0x313)**

| <b>BIT</b>         | <b>7</b> | <b>6</b> | <b>5</b> | <b>4</b> | <b>3</b> | <b>2</b> | <b>1</b>    | <b>0</b> |
|--------------------|----------|----------|----------|----------|----------|----------|-------------|----------|
| <b>Field</b>       | –        | –        | –        | –        | –        | –        | CSI_OUT_EN  | –        |
| <b>Reset</b>       | –        | –        | –        | –        | –        | –        | 0b1         | –        |
| <b>Access Type</b> | –        | –        | –        | –        | –        | –        | Write, Read | –        |

| BITFIELD   | BITS | DESCRIPTION       | DECODE  |
|------------|------|-------------------|---|
| CSI_OUT_EN | 1    | Enable CSI output | 0b0: CSI output disabled<br>0x1: CSI output enabled |

**BACKTOP13 (0x314)**

| BIT         | 7              | 6 | 5 | 4 | 3 | 2 | 1 | 0 |
|-------------|----------------|---|---|---|---|---|---|---|
| Field       | soft_vc_y[3:0] |   |   |   | – | – | – | – |
| Reset       | 0x0            |   |   |   | – | – | – | – |
| Access Type | Write, Read    |   |   |   | – | – | – | – |

| BITFIELD  | BITS | DESCRIPTION  | DECODE  |
|-----------|------|--|---|
| soft_vc_y | 7:4  | Software-defined virtual channel number for Pipeline Y | 0xX: Software-defined virtual channel number for Pipeline Y |

**BACKTOP14 (0x315)**

| BIT         | 7 | 6 | 5 | 4 | 3              | 2 | 1 | 0 |
|-------------|---|---|---|---|----------------|---|---|---|
| Field       | – | – | – | – | soft_vc_z[3:0] |   |   |   |
| Reset       | – | – | – | – | 0x0            |   |   |   |
| Access Type | – | – | – | – | Write, Read    |   |   |   |

| BITFIELD  | BITS | DESCRIPTION  | DECODE  |
|-----------|------|--|---|
| soft_vc_z | 3:0  | Software-defined virtual channel number for Pipeline Z | 0xX: Software-defined virtual channel number for Pipeline Z |

**BACKTOP15 (0x316)**

| BIT         | 7                | 6 | 5 | 4 | 3 | 2 | 1 | 0 |
|-------------|------------------|---|---|---|---|---|---|---|
| Field       | soft_dt_y_h[1:0] |   | – | – | – | – | – | – |
| Reset       | 0b00             |   | – | – | – | – | – | – |
| Access Type | Write, Read      |   | – | – | – | – | – | – |

| BITFIELD    | BITS | DESCRIPTION  | DECODE   |
|-------------|------|--|--|
| soft_dt_y_h | 7:6  | High bits of software-defined data type for Pipeline Y | 0bXX: High bits of software-defined data type for Pipeline Y |

**BACKTOP16 (0x317)**

| BIT         | 7                | 6 | 5 | 4 | 3                | 2 | 1 | 0 |
|-------------|------------------|---|---|---|------------------|---|---|---|
| Field       | soft_dt_z_h[3:0] |   |   |   | soft_dt_y_l[3:0] |   |   |   |
| Reset       | 0x0              |   |   |   | 0x0              |   |   |   |
| Access Type | Write, Read      |   |   |   | Write, Read      |   |   |   |

| BITFIELD    | BITS | DESCRIPTION  | DECODE  |
|-------------|------|--|---|
| soft_dt_z_h | 7:4  | High bits of software-defined data type for Pipeline Z | 0xX: High bits of software-defined data type for Pipeline Z |
| soft_dt_y_l | 3:0  | Low bits of software-defined data type for Pipeline Y  | 0bXX: Low bits of software-defined data type for Pipeline Y |

**BACKTOP17 (0x318)**

| BIT         | 7 | 6 | 5 | 4 | 3 | 2 | 1                | 0 |
|-------------|---|---|---|---|---|---|------------------|---|
| Field       | – | – | – | – | – | – | soft_dt_z_l[1:0] |   |
| Reset       | – | – | – | – | – | – | 0b00             |   |
| Access Type | – | – | – | – | – | – | Write, Read      |   |

| BITFIELD    | BITS | DESCRIPTION   | DECODE  |
|-------------|------|---|---|
| soft_dt_z_l | 1:0  | Low bits of software-defined data type for Pipeline Z | 0bXX: Low bits of software-defined data type for Pipeline Z |

**BACKTOP18 (0x319)**

| BIT         | 7                 | 6 | 5 | 4               | 3 | 2 | 1 | 0 |
|-------------|-------------------|---|---|-----------------|---|---|---|---|
| Field       | soft_bpp_z_h[2:0] |   |   | soft_bpp_y[4:0] |   |   |   |   |
| Reset       | 0b000             |   |   | 0b00000         |   |   |   |   |
| Access Type | Write, Read       |   |   | Write, Read     |   |   |   |   |

| BITFIELD     | BITS | DESCRIPTION                                      | DECODE  |
|--------------|------|--|---|
| soft_bpp_z_h | 7:5  | High bits of software-defined bpp for Pipeline Z | 0bXX: High bits of software-defined bpp for Pipeline Z  |
| soft_bpp_y   | 4:0  | Software-defined bpp for Pipeline Y              | 0x8: Datatypes = x2A, x10-12, x31-37<br>0xA: Datatypes = x2B<br>0xC: Datatypes = x2C<br>0xE: Datatypes = x2D<br>0x10: Datatypes = x22, x1E, x2E,<br>0x12: Datatypes = x23<br>0x14: Datatypes = x1F, x2F<br>0x18: Datatypes = x24, x30 |

**BACKTOP19 (0x31A)**

| BIT         | 7 | 6 | 5 | 4 | 3 | 2 | 1                 | 0 |
|-------------|---|---|---|---|---|---|-------------------|---|
| Field       | – | – | – | – | – | – | soft_bpp_z_l[1:0] |   |
| Reset       | – | – | – | – | – | – | 0b00              |   |
| Access Type | – | – | – | – | – | – | Write, Read       |   |

| BITFIELD     | BITS | DESCRIPTION                                     | DECODE  |
|--------------|------|---|---|
| soft_bpp_z_l | 1:0  | Low bits of software-defined bpp for Pipeline Z | 0bXX: Low bits of software-defined bpp for Pipeline Z |

**BACKTOP20 (0x31B)**

| BIT         | 7                                      | 6 | 5 | 4 | 3 | 2 | 1 | 0 |
|-------------|--|---|---|---|---|---|---|---|
| Field       | phy0_csi_tx_dpll_fb_fraction_in_l[7:0] |   |   |   |   |   |   |   |
| Reset       | 0x00                                   |   |   |   |   |   |   |   |
| Access Type | Write, Read                            |   |   |   |   |   |   |   |

| BITFIELD                          | BITS | DESCRIPTION   | DECODE   |
|-----------------------------------|------|---|--|
| phy0_csi_tx_dpll_fb_fraction_in_l | 7:0  | Low byte of software-override value for CSI PHY0 frequency fine-tuning. See app note. | 0xXX: PHY0 frequency fine-tuning override low byte |

**BACKTOP21 (0x31C)**

| BIT   | 7 | 6        | 5        | 4 | 3                                      | 2 | 1 | 0 |
|-------|---|----------|----------|---|--|---|---|---|
| Field | – | bpp8dblz | bpp8dbly | – | phy0_csi_tx_dpll_fb_fraction_in_h[3:0] |   |   |   |
| Reset | – | 0b0      | 0b0      | – | 0x0                                    |   |   |   |

|                    |   |             |             |   |             |
|--------------------|---|-------------|-------------|---|-------------|
| <b>Access Type</b> | – | Write, Read | Write, Read | – | Write, Read |
|--------------------|---|-------------|-------------|---|-------------|

| <b>BITFIELD</b>                    | <b>BITS</b> | <b>DESCRIPTION</b>   | <b>DECODE</b>   |
|------------------------------------|-------------|--|---|
| bpp8dblz                           | 6           | bpp = 8 processed as 16-bit color enable for Pipeline Z. Used to give all video data flowing through a single pipe the same bpp, to maximize capacity of video pipeline. | 0b0: Do not process bpp = 8 as 16-bit color<br>0b1: Process bpp = 8 as 16-bit color |
| bpp8dbly                           | 5           | bpp = 8 processed as 16-bit color enable for Pipeline Y. Used to give all video data flowing through a single pipe the same bpp, to maximize capacity of video pipeline. | 0b0: Do not process bpp = 8 as 16-bit color<br>0b1: Process bpp = 8 as 16-bit color |
| phy0_csi_tx_dppll_fb_fraction_in_h | 3:0         | High nibble of software-override value for PHY0 frequency fine-tuning  | 0xX: PHY0 frequency fine-tuning override high nibble                                |

**BACKTOP22 (0x31D)**

| <b>BIT</b>         | <b>7</b>            | <b>6</b> | <b>5</b>                                | <b>4</b>                           | <b>3</b> | <b>2</b> | <b>1</b> | <b>0</b> |
|--------------------|---------------------|----------|---|------------------------------------|----------|----------|----------|----------|
| <b>Field</b>       | override_bpp_vc_dty | –        | phy0_csi_tx_dppll_fb_fraction_predef_en | phy0_csi_tx_dppll_predef_freq[4:0] |          |          |          |          |
| <b>Reset</b>       | 0b0                 | –        | 0b1                                     | 0b01111                            |          |          |          |          |
| <b>Access Type</b> | Write, Read         | –        | Write, Read                             | Write, Read                        |          |          |          |          |

| <b>BITFIELD</b>                         | <b>BITS</b> | <b>DESCRIPTION</b>  | <b>DECODE</b>   |
|---|-------------|---|---|
| override_bpp_vc_dty                     | 7           | Software-override enable for BPP, VC, and DT  | 0b0: Software-override for BPP, VC, and DT disabled<br>0x1: Software-override for BPP, VC, and DT enabled   |
| phy0_csi_tx_dppll_fb_fraction_predef_en | 5           | CSI PHY0 software-override disable for frequency fine-tuning. When set to 1, PLL uses predefined frequency from phy0_csi_tx_dppll_predef_freq bit field.  | 0b0: Software-override for frequency fine-tuning enabled<br>0x1: Software-override for frequency fine-tuning disabled   |
| phy0_csi_tx_dppll_predef_freq           | 4:0         | Determines CSI PHY0 output frequency in multiples of 100Mbps (DPHY) or 100MSPS (CPHY) (PLL for MIPI Port C in 4x2 mode). PLLs should be put in reset before changing this register (config_soft_rst_n bit). | 0x0: 80Mbps/MSPS<br>0x1: 100Mbps/MSPS<br>0x2: 200Mbps/MSPS<br>0x3: 300Mbps/MSPS<br>0x4: 400Mbps/MSPS<br>0x5: 500Mbps/MSPS<br>0x6: 600Mbps/MSPS<br>0x7: 700Mbps/MSPS<br>0x8: 800Mbps/MSPS<br>0x9: 900Mbps/MSPS<br>0xA: 1000Mbps/MSPS<br>0xB: 1100Mbps/MSPS<br>0xC: 1200Mbps/MSPS<br>0xD: 1300Mbps/MSPS<br>0xE: 1400Mbps/MSPS<br>0xF: 1500Mbps/MSPS<br>0x10: 1600Mbps/MSPS<br>0x11: 1700Mbps/MSPS |

| BITFIELD | BITS | DESCRIPTION | DECODE  |
|----------|------|-------------|---|
|          |      |             | 0x12: 1800Mbps/Msps<br>0x13: 1900Mbps/Msps<br>0x14: 2000Mbps/Msps<br>0x15: 2100Mbps/Msps<br>0x16: 2200Mbps/Msps<br>0x17: 2300Mbps/Msps<br>0x18: 2400Mbps/Msps<br>0x19: 2500Mbps/Msps<br>Others: 1500Mbps/Msps |

**BACKTOP23 (0x31E)**

| BIT         | 7                                      | 6 | 5 | 4 | 3 | 2 | 1 | 0 |
|-------------|--|---|---|---|---|---|---|---|
| Field       | phy1_csi_tx_dpll_fb_fraction_in_l[7:0] |   |   |   |   |   |   |   |
| Reset       | 0x00                                   |   |   |   |   |   |   |   |
| Access Type | Write, Read                            |   |   |   |   |   |   |   |

| BITFIELD                          | BITS | DESCRIPTION  | DECODE   |
|-----------------------------------|------|--|--|
| phy1_csi_tx_dpll_fb_fraction_in_l | 7:0  | Low byte of software-override value for CSI PHY1 frequency fine-tuning. Refer to the app note. | 0xXX: PHY1 frequency fine-tuning override low byte |

**BACKTOP24 (0x31F)**

| BIT         | 7 | 6             | 5             | 4 | 3                                      | 2 | 1 | 0 |
|-------------|---|---------------|---------------|---|--|---|---|---|
| Field       | – | bpp8dblz_mode | bpp8dbly_mode | – | phy1_csi_tx_dpll_fb_fraction_in_h[3:0] |   |   |   |
| Reset       | – | 0b0           | 0b0           | – | 0x0                                    |   |   |   |
| Access Type | – | Write, Read   | Write, Read   | – | Write, Read                            |   |   |   |

| BITFIELD                          | BITS | DESCRIPTION   | DECODE  |
|-----------------------------------|------|---|---|
| bpp8dblz_mode                     | 6    | Enable 8-bit write alternate map to RAMs for Pipeline Z               | 0b0: Write alternative map disabled<br>0x1: Write alternative map enabled |
| bpp8dbly_mode                     | 5    | Enable 8-bit write alternate map to RAMs for Pipeline Y               | 0b0: Write alternative map disabled<br>0x1: Write alternative map enabled |
| phy1_csi_tx_dpll_fb_fraction_in_h | 3:0  | High nibble of software-override value for PHY1 frequency fine-tuning | 0xX: PHY1 frequency fine-tuning override high nibble                      |

**BACKTOP25 (0x320)**

| BIT         | 7 | 6                   | 5                                       | 4                                  | 3 | 2 | 1 | 0 |
|-------------|---|---------------------|---|------------------------------------|---|---|---|---|
| Field       | – | override_bpp_vc_dtz | phy1_csi_tx_dppll_fb_fraction_predef_en | phy1_csi_tx_dppll_predef_freq[4:0] |   |   |   |   |
| Reset       | – | 0b0                 | 0b1                                     | 0b01111                            |   |   |   |   |
| Access Type | – | Write, Read         | Write, Read                             | Write, Read                        |   |   |   |   |

| BITFIELD                                | BITS | DESCRIPTION   | DECODE   |
|---|------|---|--|
| override_bpp_vc_dtz                     | 6    | Software-override enable for BPP, VC, and DT  | 0b0: Software-override for BPP, VC, and DT disabled<br>0x1: Software-override for BPP, VC, and DT enabled  |
| phy1_csi_tx_dppll_fb_fraction_predef_en | 5    | CSI PHY1 software-override disable for frequency fine-tuning. When set to 1, PLL uses predefined frequency from phy1_csi_tx_dppll_predef_freq bit field.  | fine-tuning<br>0b0: Software-override for frequency fine tuning enabled<br>0x1: Software-override for frequency fine-tuning disabled   |
| phy1_csi_tx_dppll_predef_freq           | 4:0  | Determines CSI PHY1 output frequency in multiples of 100Mbps (DPHY) or 100Msps (CPHY) (PLL for MIPI Port A in 2x4 mode, Port D in 4x2 mode). PLLs should be put in reset before changing this register (config_soft_rst_n bit). | 0x0: 80Mbps/Msps<br>0x1: 100Mbps/Msps<br>0x2: 200Mbps/Msps<br>0x3: 300Mbps/Msps<br>0x4: 400Mbps/Msps<br>0x5: 500Mbps/Msps<br>0x6: 600Mbps/Msps<br>0x7: 700Mbps/Msps<br>0x8: 800Mbps/Msps<br>0x9: 900Mbps/Msps<br>0xA: 1000Mbps/Msps<br>0xB: 1100Mbps/Msps<br>0xC: 1200Mbps/Msps<br>0xD: 1300Mbps/Msps<br>0xE: 1400Mbps/Msps<br>0xF: 1500Mbps/Msps<br>0x10: 1600Mbps/Msps<br>0x11: 1700Mbps/Msps<br>0x12: 1800Mbps/Msps<br>0x13: 1900Mbps/Msps<br>0x14: 2000Mbps/Msps<br>0x15: 2100Mbps/Msps<br>0x16: 2200Mbps/Msps<br>0x17: 2300Mbps/Msps<br>0x18: 2400Mbps/Msps<br>0x19: 2500Mbps/Msps<br>Others: 1500Mbps/Msps |

**BACKTOP26 (0x321)**

| BIT         | 7                                       | 6 | 5 | 4 | 3 | 2 | 1 | 0 |
|-------------|---|---|---|---|---|---|---|---|
| Field       | phy2_csi_tx_dppll_fb_fraction_in_l[7:0] |   |   |   |   |   |   |   |
| Reset       | 0x00                                    |   |   |   |   |   |   |   |
| Access Type | Write, Read                             |   |   |   |   |   |   |   |

| BITFIELD                           | BITS | DESCRIPTION  | DECODE   |
|------------------------------------|------|--|--|
| phy2_csi_tx_dppll_fb_fraction_in_l | 7:0  | Low byte of software-override value for CSI PHY2 frequency fine-tuning. Refer to the app note. | 0xXX: PHY2 frequency fine-tuning override low byte |

**BACKTOP27 (0x322)**

| BIT         | 7                  | 6                  | 5                  | 4                  | 3                                       | 2 | 1 | 0 |
|-------------|--------------------|--------------------|--------------------|--------------------|---|---|---|---|
| Field       | yuv_8_10_mux_mode4 | yuv_8_10_mux_mode3 | yuv_8_10_mux_mode2 | yuv_8_10_mux_mode1 | phy2_csi_tx_dppll_fb_fraction_in_h[3:0] |   |   |   |
| Reset       | 0b0                | 0b0                | 0b0                | 0b0                | 0x0                                     |   |   |   |
| Access Type | Write, Read        | Write, Read        | Write, Read        | Write, Read        | Write, Read                             |   |   |   |

| BITFIELD                           | BITS | DESCRIPTION   | DECODE   |
|------------------------------------|------|---|--|
| yuv_8_10_mux_mode4                 | 7    | Enable YUV422 8-/10-bit muxed mode support                            | 0b0: Disabled<br>0b1: Enabled                        |
| yuv_8_10_mux_mode3                 | 6    | Enable YUV422 8-/10-bit muxed mode support                            | 0b0: Disabled<br>0b1: Enabled                        |
| yuv_8_10_mux_mode2                 | 5    | Enable YUV422 8-/10-bit muxed mode support                            | 0b0: Disabled<br>0b1: Enabled                        |
| yuv_8_10_mux_mode1                 | 4    | Enable YUV422 8-/10-bit muxed mode support                            | 0b0: Disabled<br>0b1: Enabled                        |
| phy2_csi_tx_dppll_fb_fraction_in_h | 3:0  | High nibble of software-override value for PHY2 frequency fine tuning | 0xX: PHY2 frequency fine-tuning override high nibble |

**BACKTOP28 (0x323)**

| BIT         | 7 | 6 | 5                                       | 4                                  | 3 | 2 | 1 | 0 |
|-------------|---|---|---|------------------------------------|---|---|---|---|
| Field       | - | - | phy2_csi_tx_dppll_fb_fraction_predef_en | phy2_csi_tx_dppll_predef_freq[4:0] |   |   |   |   |
| Reset       | - | - | 0b1                                     | 0b01111                            |   |   |   |   |
| Access Type | - | - | Write, Read                             | Write, Read                        |   |   |   |   |

| BITFIELD                                | BITS | DESCRIPTION  | DECODE   |
|---|------|--|--|
| phy2_csi_tx_dppll_fb_fraction_predef_en | 5    | CSI PHY2 software-override disable for frequency fine-tuning. When set to 1, PLL uses predefined frequency from phy2_csi_tx_dppll_predef_freq bit field.   | 0b0: Software-override for frequency fine-tuning enabled<br>0x1: Software-override for frequency fine-tuning disabled  |
| phy2_csi_tx_dppll_predef_freq           | 4:0  | Determines CSI PHY2 output frequency in multiples of 100Mbps (DPHY) or 100Msps (CPHY) (PLL for MIPI Port B in 2x4 mode, Port E in 4x2 mode).<br>PLLs should be put in reset before changing this register (config_soft_rst_n bit). | 0x0: 80Mbps/Msps<br>0x1: 100Mbps/Msps<br>0x2: 200Mbps/Msps<br>0x3: 300Mbps/Msps<br>0x4: 400Mbps/Msps<br>0x5: 500Mbps/Msps<br>0x6: 600Mbps/Msps<br>0x7: 700Mbps/Msps<br>0x8: 800Mbps/Msps<br>0x9: 900Mbps/Msps<br>0xA: 1000Mbps/Msps<br>0xB: 1100Mbps/Msps<br>0xC: 1200Mbps/Msps<br>0xD: 1300Mbps/Msps<br>0xE: 1400Mbps/Msps<br>0xF: 1500Mbps/Msps<br>0x10: 1600Mbps/Msps<br>0x11: 1700Mbps/Msps<br>0x12: 1800Mbps/Msps<br>0x13: 1900Mbps/Msps<br>0x14: 2000Mbps/Msps<br>0x15: 2100Mbps/Msps<br>0x16: 2200Mbps/Msps<br>0x17: 2300Mbps/Msps<br>0x18: 2400Mbps/Msps<br>0x19: 2500Mbps/Msps<br>Others: 1500Mbps/Msps |

**BACKTOP29 (0x324)**

| BIT         | 7                                      | 6 | 5 | 4 | 3 | 2 | 1 | 0 |
|-------------|--|---|---|---|---|---|---|---|
| Field       | phy3_csi_tx_dppll_fb_fraction_in_[7:0] |   |   |   |   |   |   |   |
| Reset       | 0x00                                   |   |   |   |   |   |   |   |
| Access Type | Write, Read                            |   |   |   |   |   |   |   |

| BITFIELD                           | BITS | DESCRIPTION  | DECODE   |
|------------------------------------|------|--|--|
| phy3_csi_tx_dppll_fb_fraction_in_l | 7:0  | Low byte of software-override value for CSI PHY3 frequency fine-tuning. Refer to the app note. | 0xXX: PHY3 frequency fine-tuning override low byte |

**BACKTOP30 (0x325)**

| BIT   | 7               | 6 | 5 | 4 | 3                                       | 2 | 1 | 0 |
|-------|-----------------|---|---|---|---|---|---|---|
| Field | BACKTOP_W_FRAME | – | – | – | phy3_csi_tx_dppll_fb_fraction_in_h[3:0] |   |   |   |

|                    |             |   |   |   |             |
|--------------------|-------------|---|---|---|-------------|
| <b>Reset</b>       | 0b0         | - | - | - | 0x0         |
| <b>Access Type</b> | Write, Read | - | - | - | Write, Read |

| BITFIELD                           | BITS | DESCRIPTION  | DECODE   |
|------------------------------------|------|--|--|
| BACKTOP_W_FRAME                    | 7    | When this register is set, BACKTOP (line buffer memory) waits for a new frame before generating MIPI packet requests to the MIPI TX. | 0b0: Does not wait for a new frame start<br>0b1: Waits for a frame start |
| phy3_csi_tx_dppll_fb_fraction_in_h | 3:0  | High nibble of software-override value for PHY3 frequency fine-tuning  | 0xX: PHY3 frequency fine-tuning override high nibble                     |

**BACKTOP31 (0x326)**

| BIT                | 7 | 6 | 5                                       | 4                                  | 3 | 2 | 1 | 0 |
|--------------------|---|---|---|------------------------------------|---|---|---|---|
| <b>Field</b>       | - | - | phy3_csi_tx_dppll_fb_fraction_predef_en | phy3_csi_tx_dppll_predef_freq[4:0] |   |   |   |   |
| <b>Reset</b>       | - | - | 0b1                                     | 0b01111                            |   |   |   |   |
| <b>Access Type</b> | - | - | Write, Read                             | Write, Read                        |   |   |   |   |

| BITFIELD                                | BITS | DESCRIPTION   | DECODE   |
|---|------|---|--|
| phy3_csi_tx_dppll_fb_fraction_predef_en | 5    | CSI PHY3 software-override disable for frequency fine-tuning. When set to 1, PLL uses predefined frequency from phy3_csi_tx_dppll_predef_freq bit field.  | 0b0: Software-override for frequency fine-tuning enabled<br>0x1: Software-override for frequency fine-tuning disabled  |
| phy3_csi_tx_dppll_predef_freq           | 4:0  | Determines CSI PHY3 output frequency in multiples of 100Mbps (DPHY) or 100MSPs (CPHY) (PLL for MIPI Port F in 4x2 mode). PLLs should be put in reset before changing this register (config_soft_rst_n bit). | 0x0: 80Mbps/MSPs<br>0x1: 100Mbps/MSPs<br>0x2: 200Mbps/MSPs<br>0x3: 300Mbps/MSPs<br>0x4: 400Mbps/MSPs<br>0x5: 500Mbps/MSPs<br>0x6: 600Mbps/MSPs<br>0x7: 700Mbps/MSPs<br>0x8: 800Mbps/MSPs<br>0x9: 900Mbps/MSPs<br>0xA: 1000Mbps/MSPs<br>0xB: 1100Mbps/MSPs<br>0xC: 1200Mbps/MSPs<br>0xD: 1300Mbps/MSPs<br>0xE: 1400Mbps/MSPs<br>0xF: 1500Mbps/MSPs<br>0x10: 1600Mbps/MSPs<br>0x11: 1700Mbps/MSPs<br>0x12: 1800Mbps/MSPs<br>0x13: 1900Mbps/MSPs<br>0x14: 2000Mbps/MSPs<br>0x15: 2100Mbps/MSPs<br>0x16: 2200Mbps/MSPs<br>0x17: 2300Mbps/MSPs<br>0x18: 2400Mbps/MSPs |

| BITFIELD | BITS | DESCRIPTION | DECODE                                       |
|----------|------|-------------|--|
|          |      |             | 0x19: 2500Mbps/Msps<br>Others: 1500Mbps/Msps |

**BACKTOP32 (0x327)**

| BIT         | 7 | 6              | 5              | 4 | 3 | 2           | 1           | 0 |
|-------------|---|----------------|----------------|---|---|-------------|-------------|---|
| Field       | – | bpp10dblz_mode | bpp10dbly_mode | – | – | bpp10dblz   | bpp10dbly   | – |
| Reset       | – | 0b0            | 0b0            | – | – | 0b0         | 0b0         | – |
| Access Type | – | Write, Read    | Write, Read    | – | – | Write, Read | Write, Read | – |

| BITFIELD       | BITS | DESCRIPTION  | DECODE  |
|----------------|------|--|---|
| bpp10dblz_mode | 6    | Enable 8-bit write alternate map to RAMs for Pipeline Z  | 0b0: Write alternative map disabled<br>0x1: Write alternative map enabled           |
| bpp10dbly_mode | 5    | Enable 8-bit write alternate map to RAMs for Pipeline Y  | 0b0: Write alternative map disabled<br>0x1: Write alternative map enabled           |
| bpp10dblz      | 2    | bpp = 8 processed as 16-bit color enable for Pipeline Z. Used to give all video data flowing through a single pipe the same bpp, to maximize capacity of video pipeline. | 0b0: Do not process bpp = 8 as 16-bit color<br>0b1: Process bpp = 8 as 16-bit color |
| bpp10dbly      | 1    | bpp = 8 processed as 16-bit color enable for Pipeline Y. Used to give all video data flowing through a single pipe the same bpp, to maximize capacity of video pipeline. | 0b0: Do not process bpp = 8 as 16-bit color<br>0b1: Process bpp = 8 as 16-bit color |

**BACKTOP33 (0x328)**

| BIT         | 7 | 6 | 5 | 4 | 3 | 2           | 1           | 0 |
|-------------|---|---|---|---|---|-------------|-------------|---|
| Field       | – | – | – | – | – | bpp12dblz   | bpp12dbly   | – |
| Reset       | – | – | – | – | – | 0b0         | 0b0         | – |
| Access Type | – | – | – | – | – | Write, Read | Write, Read | – |

| BITFIELD  | BITS | DESCRIPTION  | DECODE  |
|-----------|------|--|---|
| bpp12dblz | 2    | bpp = 8 processed as 16-bit color enable for Pipeline Z. Used to give all video data flowing through a single pipe the same bpp, to maximize capacity of video pipeline. | 0b0: Do not process bpp = 8 as 16-bit color<br>0b1: Process bpp = 8 as 16-bit color |
| bpp12dbly | 1    | bpp = 8 processed as 16-bit color enable for Pipeline Y. Used to give all video data flowing   | 0b0: Do not process bpp = 8 as 16-bit color<br>0b1: Process bpp = 8 as 16-bit color |

| BITFIELD | BITS | DESCRIPTION   | DECODE |
|----------|------|---|--------|
|          |      | through a single pipe the same bpp, to maximize capacity of video pipeline. |        |

**MIPI PHY0 (0x330)**

| BIT         | 7                | 6 | 5 | 4           | 3           | 2           | 1 | 0           |
|-------------|------------------|---|---|-------------|-------------|-------------|---|-------------|
| Field       | force_csi_out_en | – | – | phy_1x4b_22 | phy_1x4a_22 | phy_2x4     | – | phy_4x2     |
| Reset       | 0b0              | – | – | 0b0         | 0b0         | 0b1         | – | 0b0         |
| Access Type | Write, Read      | – | – | Write, Read | Write, Read | Write, Read | – | Write, Read |

| BITFIELD         | BITS | DESCRIPTION  | DECODE   |
|------------------|------|--|--|
| force_csi_out_en | 7    | Force CSI output clock for use in MIPI loopback test   | 0b0: CSI output clock not enabled for MIPI loopback test<br>0b1: CSI output clock enabled for MIPI loopback test   |
| phy_1x4b_22      | 4    | MIPI output configured as 2x2 and 1x4.<br>PLLs should be put in reset before changing this register (config_soft_rst_n bit). | 0b0: 1x4 and 2x2 configuration not selected<br>0b1: MIPI output configured as three ports. Port A is two two-ports, each with two data lanes using PHY0 and PH1. Port C is one four-lane port using PHY2 and PHY3        |
| phy_1x4a_22      | 3    | MIPI output configured as 1x4 and 2x2.<br>PLLs should be put in reset before changing this register (config_soft_rst_n bit). | 0b0: 1x4 and 2x2 configuration not selected<br>0b1: MIPI output configured as three ports. Port A is one port with four data lanes using PHY0 and PH1. Port C is two ports, each with two data lanes using PHY2 and PHY3 |
| phy_2x4          | 2    | MIPI output configured as 2x4.<br>PLLs should be put in reset before changing this register (config_soft_rst_n bit).         | 0b0: 2x4 not selected<br>0b1: MIPI output configured as two ports with four data lanes each. Port A uses PHY0 and PHY1, Port B uses PHY2 and PHY3.   |
| phy_4x2          | 0    | MIPI output configured as 4x2.<br>PLLs should be put in reset before changing this register (config_soft_rst_n bit).         | 0b0: 4x2 configuration not selected<br>0b1: MIPI output configured as four two-lane MIPI ports   |

**MIPI PHY1 (0x331)**

| BIT         | 7                | 6 | 5              | 4 | 3 | 2 | 1                 | 0 |
|-------------|------------------|---|----------------|---|---|---|-------------------|---|
| Field       | t_hs_przero[1:0] |   | t_hs_prep[1:0] |   | – | – | t_clk_przero[1:0] |   |
| Reset       | 0b00             |   | 0b00           |   | – | – | 0b00              |   |
| Access Type | Write, Read      |   | Write, Read    |   | – | – | Write, Read       |   |

| BITFIELD    | BITS | DESCRIPTION                                     | DECODE   |
|-------------|------|---|--|
| t_hs_przero | 7:6  | Typical DPHY data lane HS_prep + HS_zero timing | 0b00: 146ns + 24UI<br>0b01: 160ns + 24UI<br>0b10: 173ns + 24UI<br>0b11: 200ns + 24UI |

| BITFIELD     | BITS | DESCRIPTION   | DECODE   |
|--------------|------|---|--|
| t_hs_prep    | 5:4  | Typical DPHY data lane HS_prepare timing            | 0b00: 46.7ns + 4UI<br>0b01: 53.4ns + 4UI<br>0b10: 60.0ns + 4UI<br>0b11: 66.7ns + 4UI |
| t_clk_przero | 1:0  | Typical DPHY clock lane HS_prepare + HS_zero timing | 0b00: 306ns<br>0b01: 600ns<br>0b10: 900ns<br>0b11: 1200ns                            |

**MIPI PHY2 (0x332)**

| BIT         | 7                 | 6 | 5 | 4 | 3           | 2 | 1               | 0 |
|-------------|-------------------|---|---|---|-------------|---|-----------------|---|
| Field       | phy_Stdbby_n[3:0] |   |   |   | t_lpx[1:0]  |   | t_hs_trail[1:0] |   |
| Reset       | 0xF               |   |   |   | 0b01        |   | 0b00            |   |
| Access Type | Write, Read       |   |   |   | Write, Read |   | Write, Read     |   |

| BITFIELD     | BITS | DESCRIPTION  | DECODE   |
|--------------|------|--|--|
| phy_Stdbby_n | 7:4  | Put MIPI PHY into standby mode if not used to save power. One bit per PHY. | 0bXXX0: Put PHY0 in standby mode<br>0bXX0X: Put PHY1 in standby mode<br>0bX0XX: Put PHY2 in standby mode<br>0b0XXX: Put PHY3 in standby mode<br>0b0000: All PHYs in standby mode<br>...<br>...<br>0b1111: All PHYs not in standby mode |
| t_lpx        | 3:2  | Typical DPHY T <sub>Lpx</sub> timing                                       | 0b00: 53.4ns<br>0b01: 106.7ns<br>0b10: 160ns<br>0b11: 213.4ns  |
| t_hs_trail   | 1:0  | Typical DPHY data lane HS_trail timing                                     | 0b00: 66.7ns + 8UI<br>0b01: 80ns + 8UI<br>0b10: 93.4ns + 8UI<br>0b11: 106.7ns + 8UI  |

**MIPI PHY3 (0x333)**

| BIT         | 7                  | 6 | 5 | 4 | 3                  | 2 | 1 | 0 |
|-------------|--------------------|---|---|---|--------------------|---|---|---|
| Field       | phy1_lane_map[3:0] |   |   |   | phy0_lane_map[3:0] |   |   |   |
| Reset       | 0x4                |   |   |   | 0xE                |   |   |   |
| Access Type | Write, Read        |   |   |   | Write, Read        |   |   |   |

| BITFIELD      | BITS | DESCRIPTION   | DECODE   |
|---------------|------|---|--|
| phy1_lane_map | 7:4  | MIPI PHY1 to Port A mapping in 2 x 4 configurations | 0bXX00: Map PHY1 D0 to Port A D0<br>0bXX01: Map PHY1 D0 to Port A D1<br>0bXX10: Map PHY1 D0 to Port A D2<br>0bXX11: Map PHY1 D0 to Port A D3<br>0b00XX: Map PHY1 D1 to Port A D0 |

| BITFIELD      | BITS | DESCRIPTION   | DECODE   |
|---------------|------|---|--|
|               |      | Bits[1:0] map PHY1 data lane 0<br>Bits[3:2] map PHY1 data lane 1  | 0b01XX: Map PHY1 D1 to Port A D1<br>0b10XX: Map PHY1 D1 to Port A D2<br>0b11XX: Map PHY1 D1 to Port A D3   |
| phy0_lane_map | 3:0  | MIPI PHY0 to Port A mapping in 2 x 4 configurations<br><br>Bits[1:0] map PHY0 data lane 0<br>Bits[3:2] map PHY0 data lane 1 | 0bXX00: Map PHY0 D0 to Port A D0<br>0bXX01: Map PHY0 D0 to Port A D1<br>0bXX10: Map PHY0 D0 to Port A D2<br>0bXX11: Map PHY0 D0 to Port A D3<br>0b00XX: Map PHY0 D1 to Port A D0<br>0b01XX: Map PHY0 D1 to Port A D1<br>0b10XX: Map PHY0 D1 to Port A D2<br>0b11XX: Map PHY0 D1 to Port A D3 |

**MIPI PHY4 (0x334)**

| BIT         | 7                  | 6 | 5 | 4 | 3                  | 2 | 1 | 0 |
|-------------|--------------------|---|---|---|--------------------|---|---|---|
| Field       | phy3_lane_map[3:0] |   |   |   | phy2_lane_map[3:0] |   |   |   |
| Reset       | 0xE                |   |   |   | 0x4                |   |   |   |
| Access Type | Write, Read        |   |   |   | Write, Read        |   |   |   |

| BITFIELD      | BITS | DESCRIPTION   | DECODE   |
|---------------|------|---|--|
| phy3_lane_map | 7:4  | MIPI PHY3 to Port B mapping in 2 x 4 configurations<br><br>Bits[1:0] map PHY3 data lane 0<br>Bits[3:2] map PHY3 data lane 1 | 0bXX00: Map PHY3 D0 to Port B D0<br>0bXX01: Map PHY3 D0 to Port B D1<br>0bXX10: Map PHY3 D0 to Port B D2<br>0bXX11: Map PHY3 D0 to Port B D3<br>0b00XX: Map PHY3 D1 to Port B D0<br>0b01XX: Map PHY3 D1 to Port B D1<br>0b10XX: Map PHY3 D1 to Port B D2<br>0b11XX: Map PHY3 D1 to Port B D3 |
| phy2_lane_map | 3:0  | MIPI PHY2 to Port B mapping in 2 x 4 configurations<br><br>Bits[1:0] map PHY2 data lane 0<br>Bits[3:2] map PHY2 data lane 1 | 0bXX00: Map PHY2 D0 to Port B D0<br>0bXX01: Map PHY2 D0 to Port B D1<br>0bXX10: Map PHY2 D0 to Port B D2<br>0bXX11: Map PHY2 D0 to Port B D3<br>0b00XX: Map PHY2 D1 to Port B D0<br>0b01XX: Map PHY2 D1 to Port B D1<br>0b10XX: Map PHY2 D1 to Port B D2<br>0b11XX: Map PHY2 D1 to Port B D3 |

**MIPI PHY5 (0x335)**

| BIT         | 7               | 6 | 5                 | 4 | 3 | 2                 | 1 | 0 |
|-------------|-----------------|---|-------------------|---|---|-------------------|---|---|
| Field       | t_clk_prep[1:0] |   | phy1_pol_map[2:0] |   |   | phy0_pol_map[2:0] |   |   |
| Reset       | 0b00            |   | 0b000             |   |   | 0b000             |   |   |
| Access Type | Write, Read     |   | Write, Read       |   |   | Write, Read       |   |   |

| BITFIELD     | BITS | DESCRIPTION   | DECODE  |
|--------------|------|---|---|
| t_clk_prep   | 7:6  | Typical DPHY clock lane HS_prepare timing   | 0b00: 40ns<br>0b01: 46.7ns<br>0b10: 53.4ns<br>0b11: 60ns  |
| phy1_pol_map | 5:3  | <p>MIPI PHY1 lane polarity.</p> <p>In DPHY mode, this controls the polarity for clock, D1, and D0.<br/>In normal polarity, P is positive, N is negative. In inverse polarity, P is negative, N is positive.</p> <p>In CPHY mode, this controls the A and C pin routing in the ABC three-pin trio. In normal polarity, no pins in the ABC trio are swapped. In inverse polarity, the A and C pins are swapped.</p> | <p>0bXX0: Normal polarity for data lane 0<br/>0bXX1: Inverse polarity for data lane 0<br/>0bX0X: Normal polarity for data lane 1<br/>0bX1X: Inverse polarity for data lane 1<br/>0b0XX: Normal polarity for clock lane (DPHY only)<br/>0b1XX: Inverse polarity for clock lane (DPHY only)</p> |
| phy0_pol_map | 2:0  | <p>MIPI PHY0 lane polarity.</p> <p>In DPHY mode, this controls the polarity for clock, D1, and D0.<br/>In normal polarity, P is positive, N is negative. In inverse polarity, P is negative, N is positive.</p> <p>In CPHY mode, this controls the A and C pin routing in the ABC three-pin trio. In normal polarity, no pins in the ABC trio are swapped. In inverse polarity, the A and C pins are swapped.</p> | <p>0bXX0: Normal polarity for data lane 0<br/>0bXX1: Inverse polarity for data lane 0<br/>0bX0X: Normal polarity for data lane 1<br/>0bX1X: Inverse polarity for data lane 1<br/>0b0XX: Normal polarity for clock lane (DPHY only)<br/>0b1XX: Inverse polarity for clock lane (DPHY only)</p> |

**MIPI PHY6 (0x336)**

| BIT         | 7           | 6           | 5                 | 4 | 3 | 2                 | 1 | 0 |
|-------------|-------------|-------------|-------------------|---|---|-------------------|---|---|
| Field       | phy_cp1     | phy_cp0     | phy3_pol_map[2:0] |   |   | phy2_pol_map[2:0] |   |   |
| Reset       | 0b0         | 0b0         | 0b000             |   |   | 0b000             |   |   |
| Access Type | Write, Read | Write, Read | Write, Read       |   |   | Write, Read       |   |   |

| BITFIELD | BITS | DESCRIPTION  | DECODE   |
|----------|------|--|--|
| phy_cp1  | 7    | <p>MIPI PHY port copy enable 1.</p> <p>Used for video replication/duplication to have all video data outputting on one MIPI PHY to also output on another PHY. When enabled, the data from the PHY set in phy_cp1_src is copied to the PHY set in the phy_cp1_dst.</p> | <p>0b0: Do not copy MIPI PHY data<br/>0b1: Copy MIPI data from source PHY to destination PHY</p> |
| phy_cp0  | 6    | <p>MIPI PHY port copy enable 0.</p> <p>Used for video replication/duplication to have all video data outputting on one MIPI PHY to also output on another PHY. When enabled, the data</p>  | <p>0b0: Do not copy MIPI PHY data<br/>0b1: Copy MIPI data from source PHY to destination PHY</p> |

| BITFIELD     | BITS | DESCRIPTION   | DECODE  |
|--------------|------|---|---|
|              |      | from the PHY set in phy_cp0_src is copied to the PHY set in the phy_cp0_dst.  |   |
| phy3_pol_map | 5:3  | <p>MIPI PHY3 lane polarity.</p> <p>In DPHY mode, this controls the polarity for clock, D1, and D0.<br/>In normal polarity, P is positive, N is negative. In inverse polarity, P is negative, N is positive.</p> <p>In CPHY mode, this controls the A and C pin routing in the ABC three-pin trio. In normal polarity, no pins in the ABC trio are swapped. In inverse polarity, the A and C pins are swapped.</p> | <p>0bXX0: Normal polarity for data lane 0<br/>0bXX1: Inverse polarity for data lane 0<br/>0bX0X: Normal polarity for data lane 1<br/>0bX1X: Inverse polarity for data lane 1<br/>0b0XX: Normal polarity for clock lane (DPHY only)<br/>0b1XX: Inverse polarity for clock lane (DPHY only)</p> |
| phy2_pol_map | 2:0  | <p>MIPI PHY2 lane polarity.</p> <p>In DPHY mode, this controls the polarity for clock, D1, and D0.<br/>In normal polarity, P is positive, N is negative. In inverse polarity, P is negative, N is positive.</p> <p>In CPHY mode, this controls the A and C pin routing in the ABC three-pin trio. In normal polarity, no pins in the ABC trio are swapped. In inverse polarity, the A and C pins are swapped.</p> | <p>0bXX0: Normal polarity for data lane 0<br/>0bXX1: Inverse polarity for data lane 0<br/>0bX0X: Normal polarity for data lane 1<br/>0bX1X: Inverse polarity for data lane 1<br/>0b0XX: Normal polarity for clock lane (DPHY only)<br/>0b1XX: Inverse polarity for clock lane (DPHY only)</p> |

**MIPI PHY9 (0x339)**

| BIT         | 7                | 6 | 5 | 4 | 3 | 2 | 1 | 0                |
|-------------|------------------|---|---|---|---|---|---|------------------|
| Field       | phy_cp0_dst[1:0] |   | - | - | - | - | - | phy_cp0_overflow |
| Reset       | 0b00             |   | - | - | - | - | - | 0b0              |
| Access Type | Write, Read      |   | - | - | - | - | - | Read Clears All  |

| BITFIELD         | BITS | DESCRIPTION   | DECODE  |
|------------------|------|---|---|
| phy_cp0_dst      | 7:6  | MIPI PHY copy 0 destination. See phy_cp0 for details. | <p>0x0: Reserved<br/>0x1: MIPI PHY 1<br/>0x2: MIPI PHY 2<br/>0x3: Reserved</p>  |
| phy_cp0_overflow | 0    | PHY copy 0 FIFO overflow flag (sticky)                | <p>0b0: No overflow error has occurred<br/>0b1: Overflow error has occurred</p> |

**MIPI PHY10 (0x33A)**

| BIT   | 7                | 6 | 5 | 4 | 3 | 2 | 1 | 0                 |
|-------|------------------|---|---|---|---|---|---|-------------------|
| Field | phy_cp0_src[1:0] |   | - | - | - | - | - | phy_cp0_underflow |

|                    |             |   |   |   |   |   |                 |
|--------------------|-------------|---|---|---|---|---|-----------------|
| <b>Reset</b>       | 0b00        | – | – | – | – | – | 0b0             |
| <b>Access Type</b> | Write, Read | – | – | – | – | – | Read Clears All |

| <b>BITFIELD</b>   | <b>BITS</b> | <b>DESCRIPTION</b>                               | <b>DECODE</b>   |
|-------------------|-------------|--|---|
| phy_cp0_src       | 7:6         | MIPI PHY copy 0 source. See phy_cp0 for details. | 0x0: Reserved<br>0x1: MIPI PHY 1<br>0x2: MIPI PHY 2<br>0x3: Reserved      |
| phy_cp0_underflow | 0           | PHY copy 0 FIFO underflow flag (sticky)          | 0b0: No underflow error has occurred<br>0b1: Underflow error has occurred |

**MIPI\_PHY11 (0x33B)**

| <b>BIT</b>         | <b>7</b>         | <b>6</b> | <b>5</b> | <b>4</b> | <b>3</b> | <b>2</b> | <b>1</b> | <b>0</b>         |
|--------------------|------------------|----------|----------|----------|----------|----------|----------|------------------|
| <b>Field</b>       | phy_cp1_dst[1:0] |          | –        | –        | –        | –        | –        | phy_cp1_overflow |
| <b>Reset</b>       | 0b00             |          | –        | –        | –        | –        | –        | 0b0              |
| <b>Access Type</b> | Write, Read      |          | –        | –        | –        | –        | –        | Read Clears All  |

| <b>BITFIELD</b>  | <b>BITS</b> | <b>DESCRIPTION</b>                                    | <b>DECODE</b>   |
|------------------|-------------|---|---|
| phy_cp1_dst      | 7:6         | MIPI PHY copy 1 destination. See phy_cp1 for details. | 0x0: Reserved<br>0x1: MIPI PHY 1<br>0x2: MIPI PHY 2<br>0x3: Reserved    |
| phy_cp1_overflow | 0           | PHY copy 1 FIFO overflow flag (sticky)                | 0b0: No overflow error has occurred<br>0b1: Overflow error has occurred |

**MIPI\_PHY12 (0x33C)**

| <b>BIT</b>         | <b>7</b>         | <b>6</b> | <b>5</b> | <b>4</b> | <b>3</b> | <b>2</b> | <b>1</b> | <b>0</b>          |
|--------------------|------------------|----------|----------|----------|----------|----------|----------|-------------------|
| <b>Field</b>       | phy_cp1_src[1:0] |          | –        | –        | –        | –        | –        | phy_cp1_underflow |
| <b>Reset</b>       | 0b00             |          | –        | –        | –        | –        | –        | 0b0               |
| <b>Access Type</b> | Write, Read      |          | –        | –        | –        | –        | –        | Read Clears All   |

| <b>BITFIELD</b>   | <b>BITS</b> | <b>DESCRIPTION</b>                               | <b>DECODE</b>   |
|-------------------|-------------|--|---|
| phy_cp1_src       | 7:6         | MIPI PHY copy 1 source. See phy_cp1 for details. | 0x0: Reserved<br>0x1: MIPI PHY 1<br>0x2: MIPI PHY 2<br>0x3: Reserved      |
| phy_cp1_underflow | 0           | PHY copy 1 FIFO underflow flag (sticky)          | 0b0: No underflow error has occurred<br>0b1: Underflow error has occurred |

**MIPI\_PHY13 (0x33D)**

|                    |          |          |                    |          |          |          |          |          |
|--------------------|----------|----------|--------------------|----------|----------|----------|----------|----------|
| <b>BIT</b>         | <b>7</b> | <b>6</b> | <b>5</b>           | <b>4</b> | <b>3</b> | <b>2</b> | <b>1</b> | <b>0</b> |
| <b>Field</b>       | –        | –        | t_t3_prebegin[5:0] |          |          |          |          |          |
| <b>Reset</b>       | –        | –        | 0b000000           |          |          |          |          |          |
| <b>Access Type</b> | –        | –        | Write, Read        |          |          |          |          |          |

| <b>BITFIELD</b> | <b>BITS</b> | <b>DESCRIPTION</b>  | <b>DECODE</b>   |
|-----------------|-------------|---|---|
| t_t3_prebegin   | 5:0         | CPHY prebegin phase of the preamble (t3_prebegin + 1) x 7UI | 0xXX: CPHY prebegin time given by (t3_prebegin + 1) x 7UI |

**MIPI\_PHY14 (0x33E)**

|                    |          |                |          |          |          |          |                |          |  |
|--------------------|----------|----------------|----------|----------|----------|----------|----------------|----------|--|
| <b>BIT</b>         | <b>7</b> | <b>6</b>       | <b>5</b> | <b>4</b> | <b>3</b> | <b>2</b> | <b>1</b>       | <b>0</b> |  |
| <b>Field</b>       | –        | t_t3_post[4:0] |          |          |          |          | t_t3_prep[1:0] |          |  |
| <b>Reset</b>       | –        | 0b00100        |          |          |          |          | 0b01           |          |  |
| <b>Access Type</b> | –        | Write, Read    |          |          |          |          | Write, Read    |          |  |

| <b>BITFIELD</b> | <b>BITS</b> | <b>DESCRIPTION</b>                                   | <b>DECODE</b>  |
|-----------------|-------------|--|--|
| t_t3_post       | 6:2         | CPHY post length after HS data = (t3_post + 1) x 7UI | 0xXX: CPHY post time given by (t3_post + 1) x 7UI    |
| t_t3_prep       | 1:0         | CPHY Ths_prepare timing                              | 0x0: 40ns<br>0x1: 55ns<br>0x2: 66.7ns<br>0x3: 86.7ns |

**MIPI\_PHY15 (0x33F)**

|                    |          |          |          |          |                     |          |          |          |
|--------------------|----------|----------|----------|----------|---------------------|----------|----------|----------|
| <b>BIT</b>         | <b>7</b> | <b>6</b> | <b>5</b> | <b>4</b> | <b>3</b>            | <b>2</b> | <b>1</b> | <b>0</b> |
| <b>Field</b>       | –        | –        | –        | –        | RST_MIPITX_LOC[3:0] |          |          |          |
| <b>Reset</b>       | –        | –        | –        | –        | 0x0                 |          |          |          |
| <b>Access Type</b> | –        | –        | –        | –        | Write, Read         |          |          |          |

| <b>BITFIELD</b> | <b>BITS</b> | <b>DESCRIPTION</b>                   | <b>DECODE</b>  |
|-----------------|-------------|--------------------------------------|--|
| RST_MIPITX_LOC  | 3:0         | Active high reset to MIPI controller | 0b0000: Normal operation enabled<br>0bXX1X: Active high reset to CSI2/MIPI controller 1<br>0bX1XX: Active high reset to CSI2/MIPI controller 2<br>Others: Reserved |

| BITFIELD | BITS | DESCRIPTION   | DECODE |
|----------|------|---|--------|
|          |      | DP_RST_MIPI_CHKB must be enabled to use this reset. |        |

**MIPI PHY16 (0x340)**

| BIT         | 7 | 6 | 5                        | 4                          | 3                        | 2 | 1 | 0                    |
|-------------|---|---|--------------------------|----------------------------|--------------------------|---|---|----------------------|
| Field       | – | – | TUN_DATA_CRC_ERR_OE<br>N | TUN_ECC_UNCORR_ERR_OE<br>N | TUN_ECC_CORR_ERR_OE<br>N | – | – | VID_OVERFLOW_OE<br>N |
| Reset       | – | – | 0b0                      | 0b0                        | 0b0                      | – | – | 0b0                  |
| Access Type | – | – | Write, Read              | Write, Read                | Write, Read              | – | – | Write, Read          |

| BITFIELD               | BITS | DESCRIPTION   |
|------------------------|------|---|
| TUN_DATA_CRC_ERR_OEN   | 5    | For tunneling mode, enable reporting at ERRB pin of DPHY/CPHY data CRC errors                           |
| TUN_ECC_UNCORR_ERR_OEN | 4    | For tunneling mode, enable reporting at ERRB pin of uncorrectable errors on DPHY ECC or CPHY header CRC |
| TUN_ECC_CORR_ERR_OEN   | 3    | For tunneling mode, enable reporting at ERRB pin of correctable errors on DPHY ECC or CPHY header CRC   |
| VID_OVERFLOW_OEN       | 0    | Enable reporting of video pipe overflow (VID_OVERFLOW) at ERRB pin                                      |

**MIPI PHY17 (0x341)**

| BIT         | 7 | 6 | 5                | 4                  | 3                | 2 | 1 | 0                 |
|-------------|---|---|------------------|--------------------|------------------|---|---|-------------------|
| Field       | – | – | TUN_DATA_CRC_ERR | TUN_ECC_UNCORR_ERR | TUN_ECC_CORR_ERR | – | – | VID_OVERFLOW_FLAG |
| Reset       | – | – | 0b0              | 0b0                | 0b0              | – | – | 0b0               |
| Access Type | – | – | Read Only        | Read Only          | Read Only        | – | – | Read Only         |

| BITFIELD           | BITS | DESCRIPTION   | DECODE                                       |
|--------------------|------|---|--|
| TUN_DATA_CRC_ERR   | 5    | For tunneling mode, DPHY/CPHY data CRC errors<br><br>Combined for all MIPI PHYs. Read individual MIPI_TX STATUS registers to clear. | 0b0: Flag not asserted<br>0b1: Flag asserted |
| TUN_ECC_UNCORR_ERR | 4    | For tunneling mode, uncorrectable errors on DPHY ECC or CPHY header CRC   | 0b0: Flag not asserted<br>0b1: Flag asserted |

| BITFIELD          | BITS | DESCRIPTION  | DECODE                                       |
|-------------------|------|--|--|
|                   |      | Combined for all MIPI PHYs. Read individual MIPI_TX STATUS registers to clear.   |  |
| TUN_ECC_CORR_ERR  | 3    | For tunneling mode, correctable errors on DPHY ECC or CPHY header CRC.<br>Combined for all MIPI PHYs. Read individual MIPI_TX STATUS registers to clear. | 0b0: Flag not asserted<br>0b1: Flag asserted |
| VID_OVERFLOW_FLAG | 0    | Combined error status of all video pipe overflow (VID_OVERFLOW) bits.<br>Read individual VID_OVERFLOW bits to clear.                                     | 0b0: Flag not asserted<br>0b1: Flag asserted |

**MIPI PHY18 (0x342)**

| BIT         | 7                     | 6 | 5 | 4 | 3                     | 2 | 1 | 0 |
|-------------|-----------------------|---|---|---|-----------------------|---|---|---|
| Field       | csi2_tx2_pkt_cnt[3:0] |   |   |   | csi2_tx1_pkt_cnt[3:0] |   |   |   |
| Reset       | 0x0                   |   |   |   | 0x0                   |   |   |   |
| Access Type | Read Only             |   |   |   | Read Only             |   |   |   |

| BITFIELD         | BITS | DESCRIPTION   | DECODE  |
|------------------|------|---|---|
| csi2_tx2_pkt_cnt | 7:4  | Packet Count of CSI2 Controller 2.<br>Used for debug to determine if video data is outputting from CSI2 Controller. | 0bXXXX: Number of packets out since video started |
| csi2_tx1_pkt_cnt | 3:0  | Packet Count of CSI2 Controller 1.<br>Used for debug to determine if video data is outputting from CSI2 Controller. | 0bXXXX: Number of packets out since video started |

**MIPI PHY19 (0x343)**

| BIT         | 7                      | 6 | 5 | 4 | 3                      | 2 | 1 | 0 |
|-------------|------------------------|---|---|---|------------------------|---|---|---|
| Field       | csi2_dup2_pkt_cnt[3:0] |   |   |   | csi2_dup1_pkt_cnt[3:0] |   |   |   |
| Reset       | 0x0                    |   |   |   | 0x0                    |   |   |   |
| Access Type | Read Only              |   |   |   | Read Only              |   |   |   |

| BITFIELD          | BITS | DESCRIPTION   | DECODE  |
|-------------------|------|---|---|
| csi2_dup2_pkt_cnt | 7:4  | Packet Count of CSI2 Duplication 2.<br>Used for debug to determine if video data is outputting from CSI2 Duplication. | 0bXXXX: Number of packets out since video started |
| csi2_dup1_pkt_cnt | 3:0  | Packet Count of CSI2 Duplication 1.<br>Used for debug to determine if video data is outputting from CSI2 Duplication. | 0bXXXX: Number of packets out since video started |

**MIPI PHY20 (0x344)**

| BIT         | 7                 | 6 | 5 | 4 | 3                 | 2 | 1 | 0 |
|-------------|-------------------|---|---|---|-------------------|---|---|---|
| Field       | phy1_pkt_cnt[3:0] |   |   |   | phy0_pkt_cnt[3:0] |   |   |   |
| Reset       | 0x0               |   |   |   | 0x0               |   |   |   |
| Access Type | Read Only         |   |   |   | Read Only         |   |   |   |

| BITFIELD     | BITS | DESCRIPTION  | DECODE  |
|--------------|------|--|---|
| phy1_pkt_cnt | 7:4  | Packet Count of MIPI PHY1.<br>Used for debug to determine if video data is outputting from MIPI PHY. | 0bXXXX: Number of packets out since video started |
| phy0_pkt_cnt | 3:0  | Packet Count of MIPI PHY0.<br>Used for debug to determine if video data is outputting from MIPI PHY. | 0bXXXX: Number of packets out since video started |

**MIPI PHY21 (0x345)**

| BIT         | 7                 | 6 | 5 | 4 | 3                 | 2 | 1 | 0 |
|-------------|-------------------|---|---|---|-------------------|---|---|---|
| Field       | phy3_pkt_cnt[3:0] |   |   |   | phy2_pkt_cnt[3:0] |   |   |   |
| Reset       | 0x0               |   |   |   | 0x0               |   |   |   |
| Access Type | Read Only         |   |   |   | Read Only         |   |   |   |

| BITFIELD     | BITS | DESCRIPTION  | DECODE  |
|--------------|------|--|---|
| phy3_pkt_cnt | 7:4  | Packet Count of MIPI PHY3.<br>Used for debug to determine if video data is outputting from MIPI PHY. | 0bXXXX: Number of packets out since video started |
| phy2_pkt_cnt | 3:0  | Packet Count of MIPI PHY2.<br>Used for debug to determine if video data is outputting from MIPI PHY. | 0bXXXX: Number of packets out since video started |

**MIPI PRBS 0 (0x350)**

| BIT         | 7                        | 6 | 5                        | 4 | 3                        | 2 | 1                        | 0 |
|-------------|--------------------------|---|--------------------------|---|--------------------------|---|--------------------------|---|
| Field       | MIPI_PRBS_EN_P1_LN1[1:0] |   | MIPI_PRBS_EN_P1_LN0[1:0] |   | MIPI_PRBS_EN_P0_LN1[1:0] |   | MIPI_PRBS_EN_P0_LN0[1:0] |   |
| Reset       | 0b00                     |   | 0b00                     |   | 0b00                     |   | 0b00                     |   |
| Access Type | Write, Read              |   | Write, Read              |   | Write, Read              |   | Write, Read              |   |

| BITFIELD            | BITS | DESCRIPTION  | DECODE   |
|---------------------|------|--|--|
| MIPI_PRBS_EN_P1_LN1 | 7:6  | PRBS Enable for PHY1 Lane 1 Eye Diagram<br>Set CPHY enable for CPHY symbols. | 0x0: Disabled<br>0x1: PRBS 9 Enabled<br>0x2: PRBS 11 Enabled<br>0x3: PRBS 18 Enabled |
| MIPI_PRBS_EN_P1_LN0 | 5:4  | PRBS Enable for PHY1 Lane 0 Eye Diagram<br>Set CPHY enable for CPHY symbols. | 0x0: Disabled<br>0x1: PRBS 9 Enabled<br>0x2: PRBS 11 Enabled<br>0x3: PRBS 18 Enabled |
| MIPI_PRBS_EN_P0_LN1 | 3:2  | PRBS Enable for PHY0 Lane 1 Eye Diagram<br>Set CPHY enable for CPHY symbols. | 0x0: Disabled<br>0x1: PRBS 9 Enabled<br>0x2: PRBS 11 Enabled<br>0x3: PRBS 18 Enabled |
| MIPI_PRBS_EN_P0_LN0 | 1:0  | PRBS Enable for PHY0 Lane 0 Eye Diagram<br>Set CPHY enable for CPHY symbols. | 0x0: Disabled<br>0x1: PRBS 9 Enabled<br>0x2: PRBS 11 Enabled<br>0x3: PRBS 18 Enabled |

**MIPI PRBS 1 (0x351)**

| BIT         | 7                        | 6 | 5                        | 4 | 3                        | 2 | 1                        | 0 |
|-------------|--------------------------|---|--------------------------|---|--------------------------|---|--------------------------|---|
| Field       | MIPI_PRBS_EN_P3_LN1[1:0] |   | MIPI_PRBS_EN_P3_LN0[1:0] |   | MIPI_PRBS_EN_P2_LN1[1:0] |   | MIPI_PRBS_EN_P2_LN0[1:0] |   |
| Reset       | 0b00                     |   | 0b00                     |   | 0b00                     |   | 0b00                     |   |
| Access Type | Write, Read              |   | Write, Read              |   | Write, Read              |   | Write, Read              |   |

| BITFIELD            | BITS | DESCRIPTION  | DECODE   |
|---------------------|------|--|--|
| MIPI_PRBS_EN_P3_LN1 | 7:6  | PRBS Enable for PHY3 Lane 1 Eye Diagram<br>Set CPHY enable for CPHY symbols. | 0x0: Disabled<br>0x1: PRBS 9 Enabled<br>0x2: PRBS 11 Enabled<br>0x3: PRBS 18 Enabled |
| MIPI_PRBS_EN_P3_LN0 | 5:4  | PRBS Enable for PHY3 Lane 0 Eye Diagram<br>Set CPHY enable for CPHY symbols. | 0x0: Disabled<br>0x1: PRBS 9 Enabled<br>0x2: PRBS 11 Enabled<br>0x3: PRBS 18 Enabled |
| MIPI_PRBS_EN_P2_LN1 | 3:2  | PRBS Enable for PHY2 Lane 1 Eye Diagram<br>Set CPHY enable for CPHY symbols. | 0x0: Disabled<br>0x1: PRBS 9 Enabled<br>0x2: PRBS 11 Enabled<br>0x3: PRBS 18 Enabled |

| BITFIELD            | BITS | DESCRIPTION  | DECODE   |
|---------------------|------|--|--|
| MIPI_PRBS_EN_P2_LN0 | 1:0  | PRBS Enable for PHY2 Lane 0 Eye Diagram<br>Set CPHY enable for CPHY symbols. | 0x0: Disabled<br>0x1: PRBS 9 Enabled<br>0x2: PRBS 11 Enabled<br>0x3: PRBS 18 Enabled |

**FSYNC 0 (0x3E0)**

| BIT         | 7               | 6 | 5             | 4           | 3               | 2 | 1               | 0 |
|-------------|-----------------|---|---------------|-------------|-----------------|---|-----------------|---|
| Field       | EN_OFLOW_RST_FS | – | FSYNC_OUT_PIN | EN_VS_GEN   | FSYNC_MODE[1:0] |   | FSYNC_METH[1:0] |   |
| Reset       | 0b0             | – | 0b0           | 0b0         | 0b11            |   | 0b10            |   |
| Access Type | Write, Read     | – | Write, Read   | Write, Read | Write, Read     |   | Write, Read     |   |

| BITFIELD        | BITS | DESCRIPTION   | DECODE  |
|-----------------|------|---|---|
| EN_OFLOW_RST_FS | 7    | When enabled, memory overflow resets frame sync generation  | 0b0: Do not reset frame sync generation when memory overflow occurs<br>0b1: Reset frame sync generation when memory overflow occurs   |
| FSYNC_OUT_PIN   | 5    | Select pin to output frame sync signal (effective only when FSYNC_METH = 01)                              | 0b0: Reserved<br>0b1: MFPO  |
| EN_VS_GEN       | 4    | When enabled, VS is generated internally by the frame sync generator (not effective when FSYNC_MODE = 11) | 0x0: Internal frame sync does not generate VS<br>0x1: Internal frame sync generates VS  |
| FSYNC_MODE      | 3:2  | Frame Synchronization Mode  | GMSL2/3:<br><br>0b00: Frame sync generation is on. FSYNC_OUT pin is not used as FSYNC output, but a GPIO on the remote side can be used<br>0b01: Frame sync generation is on. FSYNC_OUT pin is used as FSYNC output and drives subordinate device, and a GPIO on the remote side can be used<br>0b10: Frame sync generation is off. FSYNC_OUT pin is not used as FSYNC output.<br>0b11: Frame sync generation is off. FSYNC_OUT pin is not used as FSYNC output |
| FSYNC_METH      | 1:0  | Frame Synchronization Method  | 0b00: Manual<br>0b01: Semi-auto<br>0b10: Auto<br>0b11: Reserved   |

**FSYNC 1 (0x3E1)**

| BIT   | 7 | 6 | 5 | 4 | 3                  | 2 | 1 | 0 |
|-------|---|---|---|---|--------------------|---|---|---|
| Field | – | – | – | – | FSYNC_PER_DIV[3:0] |   |   |   |
| Reset | – | – | – | – | 0x0                |   |   |   |

|             |   |   |   |   |             |
|-------------|---|---|---|---|-------------|
| Access Type | - | - | - | - | Write, Read |
|-------------|---|---|---|---|-------------|

| BITFIELD      | BITS | DESCRIPTION  | DECODE   |
|---------------|------|--|--|
| FSYNC_PER_DIV | 3:0  | Frame sync transmission period in terms of V <sub>SYNC</sub> periods | 0x0: 1<br>0x1: 2<br>0x2: 4<br>0x3: 6<br>0x4: 8<br>0x5: 10<br>0x6: 12<br>0x7: 16<br>0x8: 20<br>0x9: 24<br>0xA: 32<br>0xB: 48<br>0xC: 64<br>0xD: 80<br>0xE: 96<br>0xF: 128 |

**FSYNC\_2 (0x3E2)**

| BIT         | 7                 | 6 | 5 | 4           | 3           | 2 | 1 | 0 |
|-------------|-------------------|---|---|-------------|-------------|---|---|---|
| Field       | MST_LINK_SEL[2:0] |   |   | K_VAL_SIGN  | K_VAL[3:0]  |   |   |   |
| Reset       | 0b100             |   |   | 0b0         | 0x1         |   |   |   |
| Access Type | Write, Read       |   |   | Write, Read | Write, Read |   |   |   |

| BITFIELD     | BITS | DESCRIPTION   | DECODE   |
|--------------|------|---|--|
| MST_LINK_SEL | 7:5  | Main link select for frame sync generation  | 0b000: Reserved<br>0b001: Video Y<br>0b010: Video Z<br>0b011: Reserved<br>0b100: Auto select<br>0b101: Auto select<br>0b110: Auto select<br>0b111: Auto select       |
| K_VAL_SIGN   | 4    | Sign bit of K_VAL   | 0b0: K_VAL is positive<br>0b1: K_VAL is negative   |
| K_VAL        | 3:0  | Desired frame sync margin (microseconds, typical) with respect to the V <sub>SYNC</sub> of the slowest link in auto mode or with respect to the V <sub>SYNC</sub> of the main link in semi-auto mode. | 0x0: 1<br>0x1: 2<br>0x2: 3<br>0x3: 4<br>0x4: 5<br>0x5: 6<br>0x6: 7<br>0x7: 8<br>0x8: 10<br>0x9: 12<br>0xA: 14<br>0xB: 16<br>0xC: 20<br>0xD: 24<br>0xE: 28<br>0xF: 32 |

**FSYNC 3 (0x3E3)**

| BIT         | 7            | 6 | 5 | 4 | 3 | 2 | 1 | 0 |
|-------------|--------------|---|---|---|---|---|---|---|
| Field       | P_VAL_L[7:0] |   |   |   |   |   |   |   |
| Reset       | 0x00         |   |   |   |   |   |   |   |
| Access Type | Write, Read  |   |   |   |   |   |   |   |

| BITFIELD | BITS | DESCRIPTION  | DECODE  |
|----------|------|--|---|
| P_VAL_L  | 7:0  | Low byte of desired frame sync margin in terms of PCLK cycles with respect to the V <sub>SYNC</sub> of the slowest link in auto mode or with respect to the V <sub>SYNC</sub> of the main link in semi-auto mode | 0xXX: Low byte of PCLK cycles frame sync margin |

**FSYNC 4 (0x3E4)**

| BIT         | 7 | 6 | 5           | 4            | 3 | 2 | 1 | 0 |
|-------------|---|---|-------------|--------------|---|---|---|---|
| Field       | – | – | P_VAL_SIGN  | P_VAL_H[4:0] |   |   |   |   |
| Reset       | – | – | 0b0         | 0b00000      |   |   |   |   |
| Access Type | – | – | Write, Read | Write, Read  |   |   |   |   |

| BITFIELD   | BITS | DESCRIPTION   | DECODE  |
|------------|------|---|---|
| P_VAL_SIGN | 5    | Sign bit of P_VAL   | 0b0: P_VAL is positive<br>0b1: P_VAL is negative    |
| P_VAL_H    | 4:0  | High bits of desired frame sync margin in terms of PCLK cycles with respect to the V <sub>SYNC</sub> of the slowest link in auto mode or with respect to the V <sub>SYNC</sub> of the main link in semi-auto mode | 0b00000: High bits of PCLK cycles frame sync margin |

**FSYNC 5 (0x3E5)**

| BIT         | 7                   | 6 | 5 | 4 | 3 | 2 | 1 | 0 |
|-------------|---------------------|---|---|---|---|---|---|---|
| Field       | FSYNC_PERIOD_L[7:0] |   |   |   |   |   |   |   |
| Reset       | 0x00                |   |   |   |   |   |   |   |
| Access Type | Write, Read         |   |   |   |   |   |   |   |

| BITFIELD       | BITS | DESCRIPTION  | DECODE  |
|----------------|------|--|---|
| FSYNC_PERIOD_L | 7:0  | Low byte of frame sync period in terms of pixel clock effective when FSYNC_METH (0x3E0) = 00 and FSYNC_MODE (0x3E0) = 0x | 0xXX: Low byte of PCLK cycles in frame period |

**FSYNC 6 (0x3E6)**

| BIT         | 7                   | 6 | 5 | 4 | 3 | 2 | 1 | 0 |
|-------------|---------------------|---|---|---|---|---|---|---|
| Field       | FSYNC_PERIOD_M[7:0] |   |   |   |   |   |   |   |
| Reset       | 0x00                |   |   |   |   |   |   |   |
| Access Type | Write, Read         |   |   |   |   |   |   |   |

| BITFIELD       | BITS | DESCRIPTION   | DECODE   |
|----------------|------|---|--|
| FSYNC_PERIOD_M | 7:0  | Middle byte of frame sync period in terms of pixel clock (effective when FSYNC_METH (0x3E0) = 00 and FSYNC_MODE (0x3E0) = 0x) | 0xXX: Middle byte of PCLK cycles in frame period |

**FSYNC 7 (0x3E7)**

| BIT         | 7                   | 6 | 5 | 4 | 3 | 2 | 1 | 0 |
|-------------|---------------------|---|---|---|---|---|---|---|
| Field       | FSYNC_PERIOD_H[7:0] |   |   |   |   |   |   |   |
| Reset       | 0x00                |   |   |   |   |   |   |   |
| Access Type | Write, Read         |   |   |   |   |   |   |   |

| BITFIELD       | BITS | DESCRIPTION   | DECODE   |
|----------------|------|---|--|
| FSYNC_PERIOD_H | 7:0  | High byte of frame sync period in terms of pixel clock (effective when FSYNC_METH (0x3E0) = 00 and FSYNC_MODE (0x3E0) = 0x) | 0xXX: High byte of PCLK cycles in frame period |

**FSYNC 8 (0x3E8)**

| BIT         | 7                       | 6 | 5 | 4 | 3 | 2 | 1 | 0 |
|-------------|-------------------------|---|---|---|---|---|---|---|
| Field       | FRM_DIFF_ERR_THR_L[7:0] |   |   |   |   |   |   |   |
| Reset       | 0x00                    |   |   |   |   |   |   |   |
| Access Type | Write, Read             |   |   |   |   |   |   |   |

| BITFIELD           | BITS | DESCRIPTION  | DECODE   |
|--------------------|------|--|--|
| FRM_DIFF_ERR_THR_L | 7:0  | <p>Low byte of the error threshold for difference between the earliest and latest V<sub>SYNCS</sub> in terms of PCLK cycles.</p> <p>The default is 40μs for 96MHz PCLK. The function is disabled when all 13 bits are zeros.</p> | 0xXX: Low byte of PCLK cycles in the VSYNC error threshold |

**FSYNC 9 (0x3E9)**

| BIT         | 7 | 6 | 5 | 4                       | 3 | 2 | 1 | 0 |
|-------------|---|---|---|-------------------------|---|---|---|---|
| Field       | – | – | – | FRM_DIFF_ERR_THR_H[4:0] |   |   |   |   |
| Reset       | – | – | – | 0b01111                 |   |   |   |   |
| Access Type | – | – | – | Write, Read             |   |   |   |   |

| BITFIELD           | BITS | DESCRIPTION   | DECODE  |
|--------------------|------|---|---|
| FRM_DIFF_ERR_THR_H | 4:0  | <p>High bits of the error threshold for difference between the earliest and latest V<sub>SYNCS</sub> in terms of PCLK cycles.</p> <p>The default is 40μs for 96MHz PCLK. The function is disabled when all 13 bits are zeros.</p> | 0bXXXXXX: High bits of PCLK cycles in the VSYNC error threshold |

**FSYNC 10 (0x3EA)**

| BIT         | 7                   | 6 | 5 | 4 | 3 | 2 | 1 | 0 |
|-------------|---------------------|---|---|---|---|---|---|---|
| Field       | OVL_P_WINDOW_L[7:0] |   |   |   |   |   |   |   |
| Reset       | 0x00                |   |   |   |   |   |   |   |
| Access Type | Write, Read         |   |   |   |   |   |   |   |

| BITFIELD       | BITS | DESCRIPTION   | DECODE   |
|----------------|------|---|--|
| OVL_P_WINDOW_L | 7:0  | <p>Low byte of the overlap window value in terms of PCLK cycles. The window starts from the VS rising edge from the fastest image sensor and ends when a frame sync signal is seen.</p> <p>The default is 60μs for 96MHz PCLK. The function is disabled when all 13 bits are zeros.</p> | 0xXX: Low byte of PCLK cycles in the VSYNC overlap window. |

**FSYNC 11 (0x3EB)**

| BIT         | 7            | 6 | 5 | 4                   | 3 | 2 | 1 | 0 |
|-------------|--------------|---|---|---------------------|---|---|---|---|
| Field       | EN_FSIN_LAST | – | – | OVL_P_WINDOW_H[4:0] |   |   |   |   |
| Reset       | 0b0          | – | – | 0b00000             |   |   |   |   |
| Access Type | Write, Read  | – | – | Write, Read         |   |   |   |   |

| BITFIELD       | BITS | DESCRIPTION  | DECODE  |
|----------------|------|--|---|
| EN_FSIN_LAST   | 7    | FSIN position  | 0b0: FSIN can occur anywhere with respect to VS rising edges<br>0b1: FSIN occurs after all rising edges |
| OVL_P_WINDOW_H | 4:0  | Low byte of the overlap window value in terms of PCLK cycles. The window starts from the VS rising edge from the fastest image sensor and ends when a frame sync signal is seen.<br><br>The default is 60µs for 96MHz PCLK. The function is disabled when all 13 bits are zeros. | 0bXXXXX: High bits of PCLK cycles in the VSYNC overlap window.  |

**FSYNC 15 (0x3EF)**

| BIT         | 7            | 6           | 5 | 4             | 3 | 2           | 1           | 0 |
|-------------|--------------|-------------|---|---------------|---|-------------|-------------|---|
| Field       | FS_GPIO_TYPE | FS_USE_XTAL | – | AUTO_FS_LINKS | – | FS_EN_Z     | FS_EN_Y     | – |
| Reset       | 0b1          | 0b0         | – | 0b1           | – | 0b1         | 0b1         | – |
| Access Type | Write, Read  | Write, Read | – | Write, Read   | – | Write, Read | Write, Read | – |

| BITFIELD      | BITS | DESCRIPTION  | DECODE   |
|---------------|------|--|--|
| FS_GPIO_TYPE  | 7    | Select the type of FSYNC signal to output from GPIO  | 0x0: GSML1 type<br>0x1: GSML2 type   |
| FS_USE_XTAL   | 6    | Use crystal oscillator clock for generating frame sync signal                                | 0x0: Disabled<br>0x1: Enabled  |
| AUTO_FS_LINKS | 4    | Select how links are selected for frame sync generation                                      | 0x0: Include links selected by FS_LINK_x register bits in frame sync generation<br>0x1: Include all enabled links in frame sync generation |
| FS_EN_Z       | 2    | Include Video Pipe Z in frame-sync generation<br><br>This is used only if AUTO_FS_LINKS = 0. | 0x0: Do not include Video Pipe Z in frame-sync generation<br>0x1: Include Video Pipe Z in frame-sync generation                            |
| FS_EN_Y       | 1    | Include Video Pipe Y in frame-sync generation<br><br>This is used only if AUTO_FS_LINKS = 0  | 0x0: Do not include Video Pipe Y in frame-sync generation<br>0x1: Include Video Pipe Y in frame-sync generation                            |

**FSYNC 16 (0x3F0)**

| BIT         | 7                  | 6 | 5 | 4 | 3 | 2 | 1 | 0 |
|-------------|--------------------|---|---|---|---|---|---|---|
| Field       | FSYNC_ERR_CNT[7:0] |   |   |   |   |   |   |   |
| Reset       | 0x00               |   |   |   |   |   |   |   |
| Access Type | Read Clears All    |   |   |   |   |   |   |   |

| BITFIELD      | BITS | DESCRIPTION   | DECODE                         |
|---------------|------|---|--------------------------------|
| FSYNC_ERR_CNT | 7:0  | Frame Sync Error Counter<br>Resets to 0 when read or when FSYNC_LOCKED goes high. | 0xXX: Frame sync error counter |

**FSYNC 17 (0x3F1)**

| BIT         | 7                | 6 | 5 | 4 | 3 | 2                  | 1 | 0 |
|-------------|------------------|---|---|---|---|--------------------|---|---|
| Field       | FSYNC_TX_ID[4:0] |   |   |   |   | FSYNC_ERR_THR[2:0] |   |   |
| Reset       | 0b11110          |   |   |   |   | 0b000              |   |   |
| Access Type | Write, Read      |   |   |   |   | Write, Read        |   |   |

| BITFIELD      | BITS | DESCRIPTION   | DECODE                                      |
|---------------|------|---|---|
| FSYNC_TX_ID   | 7:3  | GPIO ID used for transmitting FSYNC signal.<br>The remote side should set the corresponding GPIO_RX_ID to the same value. | 0bXXXXX: GPIO ID                            |
| FSYNC_ERR_THR | 2:0  | Frame Sync Error Threshold Reporting<br>FSYNC_ERR_FLAG is asserted when FSYNC_ERR_CNT (0x3F0) ≥ FSYNC_ERR_THR.            | 0bXXX: Frame sync error reporting threshold |

**FSYNC 18 (0x3F2)**

| BIT         | 7                   | 6 | 5 | 4 | 3 | 2 | 1 | 0 |
|-------------|---------------------|---|---|---|---|---|---|---|
| Field       | CALC_FRM_LEN_L[7:0] |   |   |   |   |   |   |   |
| Reset       | 0x00                |   |   |   |   |   |   |   |
| Access Type | Read Only           |   |   |   |   |   |   |   |

| BITFIELD       | BITS | DESCRIPTION  | DECODE  |
|----------------|------|--|---|
| CALC_FRM_LEN_L | 7:0  | Low byte of calculated VS period (number of PCLKs) of main link in auto or semi-auto synchronization mode.<br><br>Use when FSYNC_METH (0x03E) = 10 and FSYNC_MODE (0x3E) = 0x. | 0xXX: Low byte of PCLKs in VS period in main link auto or semi-auto synchronization mode. |

**FSYNC 19 (0x3F3)**

| BIT         | 7                   | 6 | 5 | 4 | 3 | 2 | 1 | 0 |
|-------------|---------------------|---|---|---|---|---|---|---|
| Field       | CALC_FRM_LEN_M[7:0] |   |   |   |   |   |   |   |
| Reset       | 0x00                |   |   |   |   |   |   |   |
| Access Type | Read Only           |   |   |   |   |   |   |   |

| BITFIELD       | BITS | DESCRIPTION   | DECODE   |
|----------------|------|---|--|
| CALC_FRM_LEN_M | 7:0  | Middle byte of calculated VS period (number of PCLKs) of main link in auto or semi-auto synchronization mode.<br><br>Use when FSYNC_METH (0x03E) = 10 and FSYNC_MODE (0x3E) = 0x. | 0xXX: Middle byte of PCLKs in VS period in main link auto or semi-auto synchronization mode. |

**FSYNC 20 (0x3F4)**

| BIT         | 7                   | 6 | 5 | 4 | 3 | 2 | 1 | 0 |
|-------------|---------------------|---|---|---|---|---|---|---|
| Field       | CALC_FRM_LEN_H[7:0] |   |   |   |   |   |   |   |
| Reset       | 0x00                |   |   |   |   |   |   |   |
| Access Type | Read Only           |   |   |   |   |   |   |   |

| BITFIELD       | BITS | DESCRIPTION   | DECODE   |
|----------------|------|---|--|
| CALC_FRM_LEN_H | 7:0  | High byte of calculated VS period (number of PCLKs) of main link in auto or semi-auto synchronization mode.<br><br>Use when FSYNC_METH (0x03E) = 10 and FSYNC_MODE (0x3E) = 0x. | 0xXX: High byte of PCLKs in VS period in main link auto or semi-auto synchronization mode. |

**FSYNC 21 (0x3F5)**

| BIT         | 7               | 6 | 5 | 4 | 3 | 2 | 1 | 0 |
|-------------|-----------------|---|---|---|---|---|---|---|
| Field       | FRM_DIFF_L[7:0] |   |   |   |   |   |   |   |
| Reset       | 0x00            |   |   |   |   |   |   |   |
| Access Type | Read Only       |   |   |   |   |   |   |   |

| BITFIELD   | BITS | DESCRIPTION   | DECODE   |
|------------|------|---|--|
| FRM_DIFF_L | 7:0  | Low byte of the difference between the fastest and the slowest frame in terms of main PCLK cycles | 0xXX: Low byte of number of PCLKs in the difference between the fastest and slowest frame. |

**FSYNC 22 (0x3F6)**

| BIT         | 7                  | 6            | 5               | 4 | 3 | 2 | 1 | 0 |
|-------------|--------------------|--------------|-----------------|---|---|---|---|---|
| Field       | FSYNC_LOSS_OF_LOCK | FSYNC_LOCKED | FRM_DIFF_H[5:0] |   |   |   |   |   |
| Reset       | 0b0                | 0b0          | 0b000000        |   |   |   |   |   |
| Access Type | Read Clears All    | Read Only    | Read Only       |   |   |   |   |   |

| BITFIELD           | BITS | DESCRIPTION  | DECODE  |
|--------------------|------|--|---|
| FSYNC_LOSS_OF_LOCK | 7    | Frame Synchronization Lost Lock Flag<br>Cleared when read.   | 0b0: Frame sync lock not lost<br>0b1: Frame sync lock lost                                      |
| FSYNC_LOCKED       | 6    | Frame Synchronization Lock Flag  | 0b0: Frame sync not locked<br>0b1: Frame sync locked  |
| FRM_DIFF_H         | 5:0  | High bits of the difference between the fastest and the slowest frame in terms of main PCLK cycles | 0bXXXXXX: High bits of number of PCLKs in the difference between the fastest and slowest frame. |

**FSYNC 23 (0x3F7)**

| BIT         | 7            | 6             | 5 | 4 | 3 | 2           | 1           | 0 |
|-------------|--------------|---------------|---|---|---|-------------|-------------|---|
| Field       | EN_SYNC_COMP | EN_LINK_RESET | – | – | – | FSYNC_OVR_Z | FSYNC_OVR_Y | – |
| Reset       | 0b0          | 0b0           | – | – | – | 0b0         | 0b0         | – |
| Access Type | Write, Read  | Write, Read   | – | – | – | Write, Read | Write, Read | – |

| BITFIELD      | BITS | DESCRIPTION   | DECODE  |
|---------------|------|---|---|
| EN_SYNC_COMP  | 7    | Bypass FSYNC sync complete term in CSI_OUT_EN (0x313).<br><br>Enabling sync complete may cause video out to stop if a GMSL link drop occurs during internal frame sync configurations.  | 0x0: Bypass FSYNC sync complete<br>0x1: Enable bypass FSYNC sync complete                                       |
| EN_LINK_RESET | 6    | Internal Frame Sync Reset Link Enable<br><br>If enabled, may not operate correctly if GMSL link drop occurs.  | 0x0: Disable link reset capability<br>0x1: Enable link reset capability   |
| FSYNC_OVR_Z   | 2    | Override of video_lock_1 during internal frame sync configuration using FS_LINK_X.<br><br>If logic 1, Link 1 continues to be seen by frame sync state machines even if GMSL link drop occurs. Not used in AUTO_FS_LINKS mode. | 0b0: Do not include Video Pipe Z in frame sync generation<br>0b1: Include Video Pipe Z in frame sync generation |
| FSYNC_OVR_Y   | 1    | Override of video_lock_1 during internal frame sync configuration using FS_LINK_X<br><br>If logic 1, Link 1 continues to be seen by frame sync state machines even if GMSL link drop occurs. Not used in AUTO_FS_LINKS mode.  | 0b0: Do not include Video Pipe Y in frame sync generation<br>0b1: Include Video Pipe Y in frame sync generation |

**MIPI\_TX10 (0x40A)**

| BIT         | 7                  | 6 | 5            | 4 | 3 | 2 | 1 | 0 |
|-------------|--------------------|---|--------------|---|---|---|---|---|
| Field       | CSI2_LANE_CNT[1:0] |   | CSI2_CPHY_EN | – | – | – | – | – |
| Reset       | 0b11               |   | 0b0          | – | – | – | – | – |
| Access Type | Write, Read        |   | Write, Read  | – | – | – | – | – |

| BITFIELD      | BITS | DESCRIPTION                   | DECODE   |
|---------------|------|-------------------------------|--|
| CSI2_LANE_CNT | 7:6  | Set number of MIPI data lanes | 0b00: One data lane<br>0b01: Two data lanes<br>0b10: Three data lanes<br>0b11: Four data lanes |
| CSI2_CPHY_EN  | 5    | Enable CPHY                   | 0b0: CPHY disabled<br>0b1: CPHY enabled  |

**MIPI\_TX1 (0x441)**

| BIT   | 7         | 6 | 5 | 4 | 3 | 2 | 1 | 0 |
|-------|-----------|---|---|---|---|---|---|---|
| Field | MODE[7:0] |   |   |   |   |   |   |   |

|                    |             |
|--------------------|-------------|
| <b>Reset</b>       | 0x00        |
| <b>Access Type</b> | Write, Read |

| BITFIELD | BITS | DESCRIPTION  | DECODE  |
|----------|------|--------------|---|
| MODE     | 7:0  | MIPI Tx Mode | 0bXXXXXXXX0: Disable MIPI VS short packet counter<br>0bXXXXXXXX1: Enable MIPI VS short packet counter |

**MIPI\_TX2 (0x442)**

| BIT                | 7           | 6 | 5 | 4 | 3 | 2 | 1 | 0 |
|--------------------|-------------|---|---|---|---|---|---|---|
| <b>Field</b>       | STATUS[7:0] |   |   |   |   |   |   |   |
| <b>Reset</b>       | 0x00        |   |   |   |   |   |   |   |
| <b>Access Type</b> | Read Only   |   |   |   |   |   |   |   |

| BITFIELD | BITS | DESCRIPTION   | DECODE  |
|----------|------|---|---|
| STATUS   | 7:0  | <p>MIPI Tx Status</p> <p>The register is split into decode segments:</p> <p>bit[0] SYNC mode enable.</p> <p>bit[1] Video sync flag</p> <p>bit[2] Loss of video sync flag</p> <p>bit[3] Tunneling mode: DPHY ECC or CPHY header CRC error (correctable)</p> <p>bit[4] Tunneling mode: DPHY ECC or CPHY header CRC error (uncorrectable)</p> <p>bit[5] Tunneling mode: DPHY/CPHY data CRC error</p> | <p>0bXXXXXXXX0: SYNC mode disabled</p> <p>0bXXXXXXXX1: SYNC mode enabled</p> <p>0bXXXXXXXX0X: Video channels not in-sync</p> <p>0bXXXXXXXX1X: Video channels in-sync</p> <p>0bXXXXX0XX: No loss of video sync</p> <p>0bXXXXX1XX: Video sync lost after last read of this register or RESET.</p> <p>0bXXXX0XXX: No tunneling ECC correctable error</p> <p>0bXXXX1XXX: Tunneling ECC correctable error after last read of this register or RESET.</p> <p>0bXXX0XXXX: No tunneling ECC uncorrectable error</p> <p>0bXXX1XXXX: Tunneling ECC uncorrectable error after last read of this register or RESET.</p> <p>0bXX0XXXXX: No tunneling data CRC error</p> <p>0bXX1XXXXX: Tunneling data CRC error after last read of this register or RESET.</p> |

**MIPI\_TX3 (0x443)**

| BIT                | 7                | 6 | 5 | 4 | 3 | 2 | 1 | 0 |
|--------------------|------------------|---|---|---|---|---|---|---|
| <b>Field</b>       | DESKEW_INIT[7:0] |   |   |   |   |   |   |   |
| <b>Reset</b>       | 0x01             |   |   |   |   |   |   |   |
| <b>Access Type</b> | Write, Read      |   |   |   |   |   |   |   |

| BITFIELD    | BITS | DESCRIPTION   | DECODE  |
|-------------|------|---|---|
| DESKEW_INIT | 7:0  | <p>DPHY Deskew Initial Calibration Control</p> <p>The register is split into six decode segments:</p> <p>bit[7] Selects auto-initial deskew calibration on or off</p> | <p>0bXXXXX000: Reserved</p> <p>0bXXXXX001: Initial deskew width = 2 x 32k UI - (t<sub>lpx</sub>+t<sub>hs_przero</sub>)[UI] - 16 UI</p> <p>0bXXXXX010: Initial deskew width = 3 x 32k UI - (t<sub>lpx</sub>+t<sub>hs_przero</sub>)[UI] - 16 UI</p> |

| BITFIELD | BITS | DESCRIPTION  | DECODE  |
|----------|------|--|---|
|          |      | bit[6] Reserved<br>bit[5] Any bit change initiates an initial calibration if bit 4 = 1<br>bit[4] Selects manual initial on or off<br>bit[3] Reserved<br>bits[2:0] Selects initial deskew width | 0bXXXXX011: Initial deskew width = 4 x 32k UI - (t_lpx+t_hs_przero)[UI] - 16 UI<br>0bXXXXX100: Initial deskew width = 5 x 32k UI - (t_lpx+t_hs_przero)[UI] - 16 UI<br>0bXXXXX101: Initial deskew width = 6 x 32k UI - (t_lpx+t_hs_przero)[UI] - 16 UI<br>0bXXXXX110: Initial deskew width = 7 x 32k UI - (t_lpx+t_hs_przero)[UI] - 16 UI<br>0bXXXXX111: Initial deskew width = 8 x 32k UI - (t_lpx+t_hs_przero)[UI] - 16 UI<br>0bXXXX0XXX: Reserved<br>0bXXXX1XXX: Reserved<br>0bXXX0XXXX: Manual initial off<br>0bXXX1XXXX: Manual initial on<br>0bXX0XXXXX: If bit 4 = 1, triggers one-time immediate initial skew calibration<br>0bXX1XXXXX: If bit 4 = 1, triggers one-time immediate initial skew calibration<br>0bX0XXXXXX: Reserved<br>0bX1XXXXXX: Reserved<br>0b0XXXXXXX: Auto initial deskew off<br>0b1XXXXXXX: Auto initial deskew on |

**MIPI TX4 (0x444)**

| BIT         | 7               | 6 | 5 | 4 | 3 | 2 | 1 | 0 |
|-------------|-----------------|---|---|---|---|---|---|---|
| Field       | DESKEW_PER[7:0] |   |   |   |   |   |   |   |
| Reset       | 0x01            |   |   |   |   |   |   |   |
| Access Type | Write, Read     |   |   |   |   |   |   |   |

| BITFIELD   | BITS | DESCRIPTION   | DECODE  |
|------------|------|---|---|
| DESKEW_PER | 7:0  | DPHY Periodic Deskew Calibration Control<br><br>The register is split into four decode segments:<br>bit[7] Selects periodic deskew calibration on or off<br>bit[6] Selects generation on rising or falling edge of VS<br>bits[5:3] Selects periodic interval<br>bits[2:0] Selects periodic deskew width | 0bXXXXX000: Reserved<br>0bXXXXX001: Periodic deskew width = 2k UI - (t_lpx+t_hs_przero)[UI] - 16 UI<br>0bXXXXX010: Periodic deskew width = 3k UI - (t_lpx+t_hs_przero)[UI] - 16 UI<br>0bXXXXX011: Periodic deskew width = 4k UI - (t_lpx+t_hs_przero)[UI] - 16 UI<br>0bXXXXX100: Periodic deskew width = 5k UI - (t_lpx+t_hs_przero)[UI] - 16 UI<br>0bXXXXX101: Periodic deskew width = 6k UI - (t_lpx+t_hs_przero)[UI] - 16 UI<br>0bXXXXX110: Periodic deskew width = 7k UI - (t_lpx+t_hs_przero)[UI] - 16 UI<br>0bXXXXX111: Periodic deskew width = 8k UI - (t_lpx+t_hs_przero)[UI] - 16 UI<br>0bXX000XXX: Periodic deskew calibration generated every frame<br>0bXX001XXX: Periodic deskew calibration generated every 2 frames<br>0bXX010XXX: Periodic deskew calibration generated every 4 frames<br>0bXX011XXX: Periodic deskew calibration generated every 8 frames<br>0bXX100XXX: Periodic deskew calibration generated every 16 frames<br>0bXX101XXX: Periodic deskew calibration generated every 32 frames<br>0bXX110XXX: Periodic deskew calibration generated |

| BITFIELD | BITS | DESCRIPTION | DECODE  |
|----------|------|-------------|---|
|          |      |             | every 64 frames<br>0bXX111XXX: Periodic deskew calibration generated every 128 frames<br>0bX0XXXXXXX: Periodic deskew calibration generated at rising edge of VS<br>0bX1XXXXXXX: Periodic deskew calibration generated at falling edge of VS<br>0b0XXXXXXX: Periodic deskew calibration off<br>0b1XXXXXXX: Periodic deskew calibration on |

**MIPI TX7 (0x447)**

| BIT         | 7                | 6 | 5 | 4 | 3 | 2 | 1 | 0 |
|-------------|------------------|---|---|---|---|---|---|---|
| Field       | CSI2_TX_GAP[7:0] |   |   |   |   |   |   |   |
| Reset       | 0x1C             |   |   |   |   |   |   |   |
| Access Type | Write, Read      |   |   |   |   |   |   |   |

| BITFIELD    | BITS | DESCRIPTION  | DECODE                           |
|-------------|------|--|----------------------------------|
| CSI2_TX_GAP | 7:0  | Number of MIPI byte clocks to wait after the HS clock has entered LP before enabling it again for the next transmission. | 0xXX: Number of MIPI byte clocks |

**MIPI TX10 (0x44A)**

| BIT         | 7                  | 6 | 5            | 4 | 3           | 2 | 1 | 0 |
|-------------|--------------------|---|--------------|---|-------------|---|---|---|
| Field       | CSI2_LANE_CNT[1:0] |   | CSI2_CPHY_EN | – | CSI_VCX_EN  | – | – | – |
| Reset       | 0b11               |   | 0b0          | – | 0b0         | – | – | – |
| Access Type | Write, Read        |   | Write, Read  | – | Write, Read | – | – | – |

| BITFIELD      | BITS | DESCRIPTION                   | DECODE   |
|---------------|------|-------------------------------|--|
| CSI2_LANE_CNT | 7:6  | Set number of MIPI data lanes | 0b00: One data lane<br>0b01: Two data lanes<br>0b10: Three data lanes<br>0b11: Four data lanes |
| CSI2_CPHY_EN  | 5    | Enable CPHY                   | 0b0: CPHY disabled<br>0b1: CPHY enabled  |
| CSI_VCX_EN    | 3    | Enable VC Extension           | 0b0: Disabled<br>0b1: Enabled  |

**MIPI TX11 (0x44B)**

| BIT | 7 | 6 | 5 | 4 | 3 | 2 | 1 | 0 |
|-----|---|---|---|---|---|---|---|---|
|-----|---|---|---|---|---|---|---|---|

|                    |               |
|--------------------|---------------|
| <b>Field</b>       | MAP_EN_L[7:0] |
| <b>Reset</b>       | 0x00          |
| <b>Access Type</b> | Write, Read   |

| BITFIELD | BITS | DESCRIPTION   | DECODE  |
|----------|------|---|---|
| MAP_EN_L | 7:0  | <p>Mapping Enable Low Byte [7:0]</p> <p>Each bit enables one of eight mapping and distribution entries (defined in MAP_SRC_x, MAP_DST_x, and MAP_DPHY_DST_x) for the current video stream.</p> <p>Non-matched virtual channel (VC) and data types (DT) pass to the corresponding CSI2 controller.</p> <p>In video pixel mode, this is used to change any VC, DT, CSI2 controller destination.</p> | <p>0xX1: Enable MAP_SRC_0 (0x44D) and MAP_DST_0 (0x44E) bitfields</p> <p>0xX2: Enable MAP_SRC_1 (0x44F) and MAP_DST_1 (0x450) bitfields</p> <p>0xX4: Enable MAP_SRC_2 (0x451) and MAP_DST_2 (0x452) bitfields</p> <p>0xX8: Enable MAP_SRC_3 (0x453) and MAP_DST_3 (0x454) bitfields</p> <p>0x1X: Enable MAP_SRC_4 (0x455) and MAP_DST_4 (0x456) bitfields</p> <p>0x2X: Enable MAP_SRC_5 (0x457) and MAP_DST_5 (0x458) bitfields</p> <p>0x4X: Enable MAP_SRC_6 (0x459) and MAP_DST_6 (0x45A) bitfields</p> <p>0x8X: Enable MAP_SRC_7 (0x45B) and MAP_DST_7 (0x45C) bitfields</p> |

**MIPI TX12 (0x44C)**

|                    |               |          |          |          |          |          |          |          |
|--------------------|---------------|----------|----------|----------|----------|----------|----------|----------|
| <b>BIT</b>         | <b>7</b>      | <b>6</b> | <b>5</b> | <b>4</b> | <b>3</b> | <b>2</b> | <b>1</b> | <b>0</b> |
| <b>Field</b>       | MAP_EN_H[7:0] |          |          |          |          |          |          |          |
| <b>Reset</b>       | 0x00          |          |          |          |          |          |          |          |
| <b>Access Type</b> | Write, Read   |          |          |          |          |          |          |          |

| BITFIELD | BITS | DESCRIPTION  | DECODE  |
|----------|------|--|---|
| MAP_EN_H | 7:0  | <p>Mapping Enable High Byte [15:8]</p> <p>Each bit enables one of eight mapping and distribution entries (defined in MAP_SRC_x, MAP_DST_x and MAP_DPHY_DST_x) for the current video stream.</p> <p>Non-matched virtual channel (VC) and data types (DT) pass to the corresponding CSI2 controller.</p> <p>In video pixel mode, this is used to change any VC, DT, CSI2 controller destination.</p> | <p>ValueEnumerationDecode</p> <p>0xX1: Enable MAP_SRC_8 (0x45D) and MAP_DST_8 (0x45E) bitfields</p> <p>0xX2: Enable MAP_SRC_9 (0x45F) and MAP_DST_9 (0x460) bitfields</p> <p>0xX4: Enable MAP_SRC_10 (0x461) and MAP_DST_10 (0x462) bitfields</p> <p>0xX8: Enable MAP_SRC_11 (0x463) and MAP_DST_11 (0x464) bitfields</p> <p>0x1X: Enable MAP_SRC_12 (0x465) and MAP_DST_12 (0x466) bitfields</p> <p>0x2X: Enable MAP_SRC_13 (0x467) and MAP_DST_13 (0x468) bitfields</p> <p>0x4X: Enable MAP_SRC_14 (0x469) and MAP_DST_14 (0x46A) bitfields</p> <p>0x8X: Enable MAP_SRC_15 (0x46B) and MAP_DST_15 (0x46C) bitfields</p> |

**MIPI TX13 (0x44D)**

|                    |                |          |          |          |          |          |          |          |
|--------------------|----------------|----------|----------|----------|----------|----------|----------|----------|
| <b>BIT</b>         | <b>7</b>       | <b>6</b> | <b>5</b> | <b>4</b> | <b>3</b> | <b>2</b> | <b>1</b> | <b>0</b> |
| <b>Field</b>       | MAP_SRC_0[7:0] |          |          |          |          |          |          |          |
| <b>Reset</b>       | 0x00           |          |          |          |          |          |          |          |
| <b>Access Type</b> | Write, Read    |          |          |          |          |          |          |          |

| <b>BITFIELD</b> | <b>BITS</b> | <b>DESCRIPTION</b>   | <b>DECODE</b>                    |
|-----------------|-------------|--|----------------------------------|
| MAP_SRC_0       | 7:0         | Mapping Source Register 0<br>The register is split into two decode segments:<br>bits[7:6] VC - Virtual channel<br>bits[5:0] DT - Data type | 0xXX: VC and DT source for map 0 |

**MIPI TX14 (0x44E)**

|                    |                |          |          |          |          |          |          |          |
|--------------------|----------------|----------|----------|----------|----------|----------|----------|----------|
| <b>BIT</b>         | <b>7</b>       | <b>6</b> | <b>5</b> | <b>4</b> | <b>3</b> | <b>2</b> | <b>1</b> | <b>0</b> |
| <b>Field</b>       | MAP_DST_0[7:0] |          |          |          |          |          |          |          |
| <b>Reset</b>       | 0x00           |          |          |          |          |          |          |          |
| <b>Access Type</b> | Write, Read    |          |          |          |          |          |          |          |

| <b>BITFIELD</b> | <b>BITS</b> | <b>DESCRIPTION</b>  | <b>DECODE</b>                         |
|-----------------|-------------|---|---------------------------------------|
| MAP_DST_0       | 7:0         | Mapping Destination Register 0<br>The register is split into two decode segments:<br>bits[7:6] VC - Virtual channel<br>bits[5:0] DT - Data type | 0xXX: VC and DT destination for map 0 |

**MIPI TX15 (0x44F)**

|                    |                |          |          |          |          |          |          |          |
|--------------------|----------------|----------|----------|----------|----------|----------|----------|----------|
| <b>BIT</b>         | <b>7</b>       | <b>6</b> | <b>5</b> | <b>4</b> | <b>3</b> | <b>2</b> | <b>1</b> | <b>0</b> |
| <b>Field</b>       | MAP_SRC_1[7:0] |          |          |          |          |          |          |          |
| <b>Reset</b>       | 0x00           |          |          |          |          |          |          |          |
| <b>Access Type</b> | Write, Read    |          |          |          |          |          |          |          |

| BITFIELD  | BITS | DESCRIPTION  | DECODE                           |
|-----------|------|--|----------------------------------|
| MAP_SRC_1 | 7:0  | Mapping Source Register 1<br>The register is split into two decode segments:<br>bits[7:6] VC - Virtual channel<br>bits[5:0] DT - Data type | 0xXX: VC and DT source for map 1 |

**MIPI\_TX16 (0x450)**

| BIT         | 7              | 6 | 5 | 4 | 3 | 2 | 1 | 0 |
|-------------|----------------|---|---|---|---|---|---|---|
| Field       | MAP_DST_1[7:0] |   |   |   |   |   |   |   |
| Reset       | 0x00           |   |   |   |   |   |   |   |
| Access Type | Write, Read    |   |   |   |   |   |   |   |

| BITFIELD  | BITS | DESCRIPTION   | DECODE                                |
|-----------|------|---|---------------------------------------|
| MAP_DST_1 | 7:0  | Mapping Destination Register 1<br>The register is split into two decode segments:<br>bits[7:6] VC - Virtual channel<br>bits[5:0] DT - Data type | 0xXX: VC and DT destination for map 1 |

**MIPI\_TX17 (0x451)**

| BIT         | 7              | 6 | 5 | 4 | 3 | 2 | 1 | 0 |
|-------------|----------------|---|---|---|---|---|---|---|
| Field       | MAP_SRC_2[7:0] |   |   |   |   |   |   |   |
| Reset       | 0x00           |   |   |   |   |   |   |   |
| Access Type | Write, Read    |   |   |   |   |   |   |   |

| BITFIELD  | BITS | DESCRIPTION  | DECODE                           |
|-----------|------|--|----------------------------------|
| MAP_SRC_2 | 7:0  | Mapping Source Register 2<br>The register is split into two decode segments:<br>bits[7:6] VC - Virtual channel<br>bits[5:0] DT - Data type | 0xXX: VC and DT source for map 2 |

**MIPI\_TX18 (0x452)**

| BIT | 7 | 6 | 5 | 4 | 3 | 2 | 1 | 0 |
|-----|---|---|---|---|---|---|---|---|
|-----|---|---|---|---|---|---|---|---|

|                    |                |
|--------------------|----------------|
| <b>Field</b>       | MAP_DST_2[7:0] |
| <b>Reset</b>       | 0x00           |
| <b>Access Type</b> | Write, Read    |

| BITFIELD  | BITS | DESCRIPTION   | DECODE                                |
|-----------|------|---|---------------------------------------|
| MAP_DST_2 | 7:0  | Mapping Destination Register 2<br><br>The register is split into two decode segments:<br>bits[7:6] VC - Virtual channel<br>bits[5:0] DT - Data type | 0xXX: VC and DT destination for map 2 |

### MIPI TX19 (0x453)

| BIT                | 7              | 6 | 5 | 4 | 3 | 2 | 1 | 0 |
|--------------------|----------------|---|---|---|---|---|---|---|
| <b>Field</b>       | MAP_SRC_3[7:0] |   |   |   |   |   |   |   |
| <b>Reset</b>       | 0x00           |   |   |   |   |   |   |   |
| <b>Access Type</b> | Write, Read    |   |   |   |   |   |   |   |

| BITFIELD  | BITS | DESCRIPTION  | DECODE                           |
|-----------|------|--|----------------------------------|
| MAP_SRC_3 | 7:0  | Mapping Source Register 3<br><br>The register is split into two decode segments:<br>bits[7:6] VC - Virtual channel<br>bits[5:0] DT - Data type | 0xXX: VC and DT source for map 3 |

### MIPI TX20 (0x454)

| BIT                | 7              | 6 | 5 | 4 | 3 | 2 | 1 | 0 |
|--------------------|----------------|---|---|---|---|---|---|---|
| <b>Field</b>       | MAP_DST_3[7:0] |   |   |   |   |   |   |   |
| <b>Reset</b>       | 0x00           |   |   |   |   |   |   |   |
| <b>Access Type</b> | Write, Read    |   |   |   |   |   |   |   |

| BITFIELD  | BITS | DESCRIPTION   | DECODE                                |
|-----------|------|---|---------------------------------------|
| MAP_DST_3 | 7:0  | Mapping Destination Register 3<br><br>The register is split into two decode segments: | 0xXX: VC and DT destination for map 3 |

| BITFIELD | BITS | DESCRIPTION  | DECODE |
|----------|------|--|--------|
|          |      | bits[7:6] VC - Virtual channel<br>bits[5:0] DT - Data type |        |

**MIPI TX21 (0x455)**

| BIT         | 7              | 6 | 5 | 4 | 3 | 2 | 1 | 0 |
|-------------|----------------|---|---|---|---|---|---|---|
| Field       | MAP_SRC_4[7:0] |   |   |   |   |   |   |   |
| Reset       | 0x00           |   |   |   |   |   |   |   |
| Access Type | Write, Read    |   |   |   |   |   |   |   |

| BITFIELD  | BITS | DESCRIPTION  | DECODE                           |
|-----------|------|--|----------------------------------|
| MAP_SRC_4 | 7:0  | Mapping Source Register 4<br><br>The register is split into two decode segments:<br>bits[7:6] VC - Virtual channel<br>bits[5:0] DT - Data type | 0xXX: VC and DT source for map 4 |

**MIPI TX22 (0x456)**

| BIT         | 7              | 6 | 5 | 4 | 3 | 2 | 1 | 0 |
|-------------|----------------|---|---|---|---|---|---|---|
| Field       | MAP_DST_4[7:0] |   |   |   |   |   |   |   |
| Reset       | 0x00           |   |   |   |   |   |   |   |
| Access Type | Write, Read    |   |   |   |   |   |   |   |

| BITFIELD  | BITS | DESCRIPTION   | DECODE                                |
|-----------|------|---|---------------------------------------|
| MAP_DST_4 | 7:0  | Mapping Destination Register 4<br><br>The register is split into two decode segments:<br>bits[7:6] VC - Virtual channel<br>bits[5:0] DT - Data type | 0xXX: VC and DT destination for map 4 |

**MIPI TX23 (0x457)**

| BIT   | 7              | 6 | 5 | 4 | 3 | 2 | 1 | 0 |
|-------|----------------|---|---|---|---|---|---|---|
| Field | MAP_SRC_5[7:0] |   |   |   |   |   |   |   |
| Reset | 0x00           |   |   |   |   |   |   |   |

|                    |             |
|--------------------|-------------|
| <b>Access Type</b> | Write, Read |
|--------------------|-------------|

| <b>BITFIELD</b> | <b>BITS</b> | <b>DESCRIPTION</b>   | <b>DECODE</b>                    |
|-----------------|-------------|--|----------------------------------|
| MAP_SRC_5       | 7:0         | Mapping Source Register 5<br>The register is split into two decode segments:<br>bits[7:6] VC - Virtual channel<br>bits[5:0] DT - Data type | 0xXX: VC and DT source for map 5 |

**MIPI TX24 (0x458)**

| <b>BIT</b>         | <b>7</b>       | <b>6</b> | <b>5</b> | <b>4</b> | <b>3</b> | <b>2</b> | <b>1</b> | <b>0</b> |
|--------------------|----------------|----------|----------|----------|----------|----------|----------|----------|
| <b>Field</b>       | MAP_DST_5[7:0] |          |          |          |          |          |          |          |
| <b>Reset</b>       | 0x00           |          |          |          |          |          |          |          |
| <b>Access Type</b> | Write, Read    |          |          |          |          |          |          |          |

| <b>BITFIELD</b> | <b>BITS</b> | <b>DESCRIPTION</b>  | <b>DECODE</b>                         |
|-----------------|-------------|---|---------------------------------------|
| MAP_DST_5       | 7:0         | Mapping Destination Register 5<br>The register is split into two decode segments:<br>bits[7:6] VC - Virtual channel<br>bits[5:0] DT - Data type | 0xXX: VC and DT destination for map 5 |

**MIPI TX25 (0x459)**

| <b>BIT</b>         | <b>7</b>       | <b>6</b> | <b>5</b> | <b>4</b> | <b>3</b> | <b>2</b> | <b>1</b> | <b>0</b> |
|--------------------|----------------|----------|----------|----------|----------|----------|----------|----------|
| <b>Field</b>       | MAP_SRC_6[7:0] |          |          |          |          |          |          |          |
| <b>Reset</b>       | 0x00           |          |          |          |          |          |          |          |
| <b>Access Type</b> | Write, Read    |          |          |          |          |          |          |          |

| <b>BITFIELD</b> | <b>BITS</b> | <b>DESCRIPTION</b>   | <b>DECODE</b>                    |
|-----------------|-------------|--|----------------------------------|
| MAP_SRC_6       | 7:0         | Mapping Source Register 6<br>The register is split into two decode segments:<br>bits[7:6] VC - Virtual channel<br>bits[5:0] DT - Data type | 0xXX: VC and DT source for map 6 |

**MIPI TX26 (0x45A)**

|                    |                |          |          |          |          |          |          |          |
|--------------------|----------------|----------|----------|----------|----------|----------|----------|----------|
| <b>BIT</b>         | <b>7</b>       | <b>6</b> | <b>5</b> | <b>4</b> | <b>3</b> | <b>2</b> | <b>1</b> | <b>0</b> |
| <b>Field</b>       | MAP_DST_6[7:0] |          |          |          |          |          |          |          |
| <b>Reset</b>       | 0x00           |          |          |          |          |          |          |          |
| <b>Access Type</b> | Write, Read    |          |          |          |          |          |          |          |

| <b>BITFIELD</b> | <b>BITS</b> | <b>DESCRIPTION</b>  | <b>DECODE</b>                         |
|-----------------|-------------|---|---------------------------------------|
| MAP_DST_6       | 7:0         | Mapping Destination Register 6<br><br>The register is split into two decode segments:<br>bits[7:6] VC - Virtual channel<br>bits[5:0] DT - Data type | 0xXX: VC and DT destination for map 6 |

**MIPI TX27 (0x45B)**

|                    |                |          |          |          |          |          |          |          |
|--------------------|----------------|----------|----------|----------|----------|----------|----------|----------|
| <b>BIT</b>         | <b>7</b>       | <b>6</b> | <b>5</b> | <b>4</b> | <b>3</b> | <b>2</b> | <b>1</b> | <b>0</b> |
| <b>Field</b>       | MAP_SRC_7[7:0] |          |          |          |          |          |          |          |
| <b>Reset</b>       | 0x00           |          |          |          |          |          |          |          |
| <b>Access Type</b> | Write, Read    |          |          |          |          |          |          |          |

| <b>BITFIELD</b> | <b>BITS</b> | <b>DESCRIPTION</b>   | <b>DECODE</b>                    |
|-----------------|-------------|--|----------------------------------|
| MAP_SRC_7       | 7:0         | Mapping Source Register 7<br><br>The register is split into two decode segments:<br>bits[7:6] VC - Virtual channel<br>bits[5:0] DT - Data type | 0xXX: VC and DT source for map 7 |

**MIPI TX28 (0x45C)**

|                    |                |          |          |          |          |          |          |          |
|--------------------|----------------|----------|----------|----------|----------|----------|----------|----------|
| <b>BIT</b>         | <b>7</b>       | <b>6</b> | <b>5</b> | <b>4</b> | <b>3</b> | <b>2</b> | <b>1</b> | <b>0</b> |
| <b>Field</b>       | MAP_DST_7[7:0] |          |          |          |          |          |          |          |
| <b>Reset</b>       | 0x00           |          |          |          |          |          |          |          |
| <b>Access Type</b> | Write, Read    |          |          |          |          |          |          |          |

| BITFIELD  | BITS | DESCRIPTION  | DECODE                                |
|-----------|------|--|---------------------------------------|
| MAP_DST_7 | 7:0  | Mapping Destination Register 7<br>The register is split into two decode segments:<br>bits [7:6] VC - Virtual channel<br>bits[5:0] DT - Data type | 0xXX: VC and DT destination for map 7 |

**MIPI TX29 (0x45D)**

| BIT         | 7              | 6 | 5 | 4 | 3 | 2 | 1 | 0 |
|-------------|----------------|---|---|---|---|---|---|---|
| Field       | MAP_SRC_8[7:0] |   |   |   |   |   |   |   |
| Reset       | 0x00           |   |   |   |   |   |   |   |
| Access Type | Write, Read    |   |   |   |   |   |   |   |

| BITFIELD  | BITS | DESCRIPTION  | DECODE                           |
|-----------|------|--|----------------------------------|
| MAP_SRC_8 | 7:0  | Mapping Source Register 8<br>The register is split into two decode segments:<br>bits[7:6] VC - Virtual channel<br>bits[5:0] DT - Data type | 0xXX: VC and DT source for map 8 |

**MIPI TX30 (0x45E)**

| BIT         | 7              | 6 | 5 | 4 | 3 | 2 | 1 | 0 |
|-------------|----------------|---|---|---|---|---|---|---|
| Field       | MAP_DST_8[7:0] |   |   |   |   |   |   |   |
| Reset       | 0x00           |   |   |   |   |   |   |   |
| Access Type | Write, Read    |   |   |   |   |   |   |   |

| BITFIELD  | BITS | DESCRIPTION   | DECODE                                |
|-----------|------|---|---------------------------------------|
| MAP_DST_8 | 7:0  | Mapping Destination Register 8<br>The register is split into two decode segments:<br>bits[7:6] VC - Virtual channel<br>bits[5:0] DT - Data type | 0xXX: VC and DT destination for map 8 |

**MIPI TX31 (0x45F)**

| BIT | 7 | 6 | 5 | 4 | 3 | 2 | 1 | 0 |
|-----|---|---|---|---|---|---|---|---|
|-----|---|---|---|---|---|---|---|---|

|                    |                |
|--------------------|----------------|
| <b>Field</b>       | MAP_SRC_9[7:0] |
| <b>Reset</b>       | 0x00           |
| <b>Access Type</b> | Write, Read    |

| BITFIELD  | BITS | DESCRIPTION  | DECODE                           |
|-----------|------|--|----------------------------------|
| MAP_SRC_9 | 7:0  | Mapping Source Register 9<br>The register is split into two decode segments:<br>bits[7:6] VC - Virtual channel<br>bits[5:0] DT - Data type | 0xXX: VC and DT source for map 9 |

**MIPI TX32 (0x460)**

|                    |                |          |          |          |          |          |          |          |
|--------------------|----------------|----------|----------|----------|----------|----------|----------|----------|
| <b>BIT</b>         | <b>7</b>       | <b>6</b> | <b>5</b> | <b>4</b> | <b>3</b> | <b>2</b> | <b>1</b> | <b>0</b> |
| <b>Field</b>       | MAP_DST_9[7:0] |          |          |          |          |          |          |          |
| <b>Reset</b>       | 0x00           |          |          |          |          |          |          |          |
| <b>Access Type</b> | Write, Read    |          |          |          |          |          |          |          |

| BITFIELD  | BITS | DESCRIPTION   | DECODE                                |
|-----------|------|---|---------------------------------------|
| MAP_DST_9 | 7:0  | Mapping Destination Register 9<br>The register is split into two decode segments:<br>bits[7:6] VC - Virtual channel<br>bits[5:0] DT - Data type | 0xXX: VC and DT destination for map 9 |

**MIPI TX33 (0x461)**

|                    |                 |          |          |          |          |          |          |          |
|--------------------|-----------------|----------|----------|----------|----------|----------|----------|----------|
| <b>BIT</b>         | <b>7</b>        | <b>6</b> | <b>5</b> | <b>4</b> | <b>3</b> | <b>2</b> | <b>1</b> | <b>0</b> |
| <b>Field</b>       | MAP_SRC_10[7:0] |          |          |          |          |          |          |          |
| <b>Reset</b>       | 0x00            |          |          |          |          |          |          |          |
| <b>Access Type</b> | Write, Read     |          |          |          |          |          |          |          |

| BITFIELD   | BITS | DESCRIPTION   | DECODE                            |
|------------|------|---|-----------------------------------|
| MAP_SRC_10 | 7:0  | Mapping Source Register 10<br>The register is split into two decode segments: | 0xXX: VC and DT source for map 10 |

| BITFIELD | BITS | DESCRIPTION  | DECODE |
|----------|------|--|--------|
|          |      | bits[7:6] VC - Virtual channel<br>bits[5:0] DT - Data type |        |

**MIPI TX34 (0x462)**

| BIT         | 7               | 6 | 5 | 4 | 3 | 2 | 1 | 0 |
|-------------|-----------------|---|---|---|---|---|---|---|
| Field       | MAP_DST_10[7:0] |   |   |   |   |   |   |   |
| Reset       | 0x00            |   |   |   |   |   |   |   |
| Access Type | Write, Read     |   |   |   |   |   |   |   |

| BITFIELD   | BITS | DESCRIPTION  | DECODE                                 |
|------------|------|--|--|
| MAP_DST_10 | 7:0  | Mapping Destination Register 10<br><br>The register is split into two decode segments:<br>bits[7:6] VC - Virtual channel<br>bits[5:0] DT - Data type | 0xXX: VC and DT destination for map 10 |

**MIPI TX35 (0x463)**

| BIT         | 7               | 6 | 5 | 4 | 3 | 2 | 1 | 0 |
|-------------|-----------------|---|---|---|---|---|---|---|
| Field       | MAP_SRC_11[7:0] |   |   |   |   |   |   |   |
| Reset       | 0x00            |   |   |   |   |   |   |   |
| Access Type | Write, Read     |   |   |   |   |   |   |   |

| BITFIELD   | BITS | DESCRIPTION   | DECODE                            |
|------------|------|---|-----------------------------------|
| MAP_SRC_11 | 7:0  | Mapping Source Register 11<br><br>The register is split into two decode segments:<br>bits[7:6] VC - Virtual channel<br>bits[5:0] DT - Data type | 0xXX: VC and DT source for map 11 |

**MIPI TX36 (0x464)**

| BIT   | 7               | 6 | 5 | 4 | 3 | 2 | 1 | 0 |
|-------|-----------------|---|---|---|---|---|---|---|
| Field | MAP_DST_11[7:0] |   |   |   |   |   |   |   |
| Reset | 0x00            |   |   |   |   |   |   |   |

|                    |             |
|--------------------|-------------|
| <b>Access Type</b> | Write, Read |
|--------------------|-------------|

| <b>BITFIELD</b> | <b>BITS</b> | <b>DESCRIPTION</b>   | <b>DECODE</b>                          |
|-----------------|-------------|--|--|
| MAP_DST_11      | 7:0         | Mapping Destination Register 11<br>The register is split into two decode segments:<br>bits[7:6] VC - Virtual channel<br>bits[5:0] DT - Data type | 0xXX: VC and DT destination for map 11 |

**MIPI TX37 (0x465)**

| <b>BIT</b>         | <b>7</b>        | <b>6</b> | <b>5</b> | <b>4</b> | <b>3</b> | <b>2</b> | <b>1</b> | <b>0</b> |
|--------------------|-----------------|----------|----------|----------|----------|----------|----------|----------|
| <b>Field</b>       | MAP_SRC_12[7:0] |          |          |          |          |          |          |          |
| <b>Reset</b>       | 0x00            |          |          |          |          |          |          |          |
| <b>Access Type</b> | Write, Read     |          |          |          |          |          |          |          |

| <b>BITFIELD</b> | <b>BITS</b> | <b>DESCRIPTION</b>  | <b>DECODE</b>                     |
|-----------------|-------------|---|-----------------------------------|
| MAP_SRC_12      | 7:0         | Mapping Source Register 12<br>The register is split into two decode segments:<br>bits[7:6] VC - Virtual channel<br>bits[5:0] DT - Data type | 0xXX: VC and DT source for map 12 |

**MIPI TX38 (0x466)**

| <b>BIT</b>         | <b>7</b>        | <b>6</b> | <b>5</b> | <b>4</b> | <b>3</b> | <b>2</b> | <b>1</b> | <b>0</b> |
|--------------------|-----------------|----------|----------|----------|----------|----------|----------|----------|
| <b>Field</b>       | MAP_DST_12[7:0] |          |          |          |          |          |          |          |
| <b>Reset</b>       | 0x00            |          |          |          |          |          |          |          |
| <b>Access Type</b> | Write, Read     |          |          |          |          |          |          |          |

| <b>BITFIELD</b> | <b>BITS</b> | <b>DESCRIPTION</b>   | <b>DECODE</b>                          |
|-----------------|-------------|--|--|
| MAP_DST_12      | 7:0         | Mapping Destination Register 12<br>The register is split into two decode segments:<br>bits[7:6] VC - Virtual channel<br>bits[5:0] DT - Data type | 0xXX: VC and DT destination for map 12 |

**MIPI TX39 (0x467)**

|                    |                 |          |          |          |          |          |          |          |
|--------------------|-----------------|----------|----------|----------|----------|----------|----------|----------|
| <b>BIT</b>         | <b>7</b>        | <b>6</b> | <b>5</b> | <b>4</b> | <b>3</b> | <b>2</b> | <b>1</b> | <b>0</b> |
| <b>Field</b>       | MAP_SRC_13[7:0] |          |          |          |          |          |          |          |
| <b>Reset</b>       | 0x00            |          |          |          |          |          |          |          |
| <b>Access Type</b> | Write, Read     |          |          |          |          |          |          |          |

| <b>BITFIELD</b> | <b>BITS</b> | <b>DESCRIPTION</b>  | <b>DECODE</b>                     |
|-----------------|-------------|---|-----------------------------------|
| MAP_SRC_13      | 7:0         | Mapping Source Register 13<br>The register is split into two decode segments:<br>bits[7:6] VC - Virtual channel<br>bits[5:0] DT - Data type | 0xXX: VC and DT source for map 13 |

**MIPI TX40 (0x468)**

|                    |                 |          |          |          |          |          |          |          |
|--------------------|-----------------|----------|----------|----------|----------|----------|----------|----------|
| <b>BIT</b>         | <b>7</b>        | <b>6</b> | <b>5</b> | <b>4</b> | <b>3</b> | <b>2</b> | <b>1</b> | <b>0</b> |
| <b>Field</b>       | MAP_DST_13[7:0] |          |          |          |          |          |          |          |
| <b>Reset</b>       | 0x00            |          |          |          |          |          |          |          |
| <b>Access Type</b> | Write, Read     |          |          |          |          |          |          |          |

| <b>BITFIELD</b> | <b>BITS</b> | <b>DESCRIPTION</b>   | <b>DECODE</b>                          |
|-----------------|-------------|--|--|
| MAP_DST_13      | 7:0         | Mapping Destination Register 13<br>The register is split into two decode segments:<br>bits[7:6] VC - Virtual channel<br>bits[5:0] DT - Data type | 0xXX: VC and DT destination for map 13 |

**MIPI TX41 (0x469)**

|                    |                 |          |          |          |          |          |          |          |
|--------------------|-----------------|----------|----------|----------|----------|----------|----------|----------|
| <b>BIT</b>         | <b>7</b>        | <b>6</b> | <b>5</b> | <b>4</b> | <b>3</b> | <b>2</b> | <b>1</b> | <b>0</b> |
| <b>Field</b>       | MAP_SRC_14[7:0] |          |          |          |          |          |          |          |
| <b>Reset</b>       | 0x00            |          |          |          |          |          |          |          |
| <b>Access Type</b> | Write, Read     |          |          |          |          |          |          |          |

| BITFIELD   | BITS | DESCRIPTION   | DECODE                            |
|------------|------|---|-----------------------------------|
| MAP_SRC_14 | 7:0  | Mapping Source Register 14<br>The register is split into two decode segments:<br>bits[7:6] VC - Virtual channel<br>bits[5:0] DT - Data type | 0xXX: VC and DT source for map 14 |

**MIPI\_TX42 (0x46A)**

| BIT         | 7               | 6 | 5 | 4 | 3 | 2 | 1 | 0 |
|-------------|-----------------|---|---|---|---|---|---|---|
| Field       | MAP_DST_14[7:0] |   |   |   |   |   |   |   |
| Reset       | 0x00            |   |   |   |   |   |   |   |
| Access Type | Write, Read     |   |   |   |   |   |   |   |

| BITFIELD   | BITS | DESCRIPTION  | DECODE                                 |
|------------|------|--|--|
| MAP_DST_14 | 7:0  | Mapping Destination Register 14<br>The register is split into two decode segments:<br>bits[7:6] VC - Virtual channel<br>bits[5:0] DT - Data type | 0xXX: VC and DT destination for map 14 |

**MIPI\_TX43 (0x46B)**

| BIT         | 7               | 6 | 5 | 4 | 3 | 2 | 1 | 0 |
|-------------|-----------------|---|---|---|---|---|---|---|
| Field       | MAP_SRC_15[7:0] |   |   |   |   |   |   |   |
| Reset       | 0x00            |   |   |   |   |   |   |   |
| Access Type | Write, Read     |   |   |   |   |   |   |   |

| BITFIELD   | BITS | DESCRIPTION   | DECODE                            |
|------------|------|---|-----------------------------------|
| MAP_SRC_15 | 7:0  | Mapping Source Register 15<br>The register is split into two decode segments:<br>bits[7:6] VC - Virtual channel<br>bits[5:0] DT - Data type | 0xXX: VC and DT source for map 15 |

**MIPI\_TX44 (0x46C)**

| BIT | 7 | 6 | 5 | 4 | 3 | 2 | 1 | 0 |
|-----|---|---|---|---|---|---|---|---|
|-----|---|---|---|---|---|---|---|---|

|                    |                 |
|--------------------|-----------------|
| <b>Field</b>       | MAP_DST_15[7:0] |
| <b>Reset</b>       | 0x00            |
| <b>Access Type</b> | Write, Read     |

| BITFIELD   | BITS | DESCRIPTION  | DECODE                                 |
|------------|------|--|--|
| MAP_DST_15 | 7:0  | Mapping Destination Register 15<br><br>The register is split into two decode segments:<br>bits[7:6] VC - Virtual channel<br>bits[5:0] DT - Data type | 0xXX: VC and DT destination for map 15 |

**MIPI TX45 (0x46D)**

| BIT                | 7                    | 6 | 5                    | 4 | 3                    | 2 | 1                    | 0 |
|--------------------|----------------------|---|----------------------|---|----------------------|---|----------------------|---|
| <b>Field</b>       | MAP_DPHY_DEST_3[1:0] |   | MAP_DPHY_DEST_2[1:0] |   | MAP_DPHY_DEST_1[1:0] |   | MAP_DPHY_DEST_0[1:0] |   |
| <b>Reset</b>       | 0b00                 |   | 0b00                 |   | 0b00                 |   | 0b00                 |   |
| <b>Access Type</b> | Write, Read          |   | Write, Read          |   | Write, Read          |   | Write, Read          |   |

| BITFIELD        | BITS | DESCRIPTION   | DECODE   |
|-----------------|------|---|--|
| MAP_DPHY_DEST_3 | 7:6  | CSI2 controller destination for MAP_SRC_3 (0x453) and MAP_DST_0 (0x44E) mapping bitfields | 0b00: Map to DPHY0 (4x2 mode only)<br>0b01: Map to DPHY1<br>0b10: Map to DPHY2<br>0b11: Map to DPHY3 (4x2 mode only) |
| MAP_DPHY_DEST_2 | 5:4  | CSI2 controller destination for MAP_SRC_2 (0x451) and MAP_DST_0 (0x44E) mapping bitfields | 0b00: Map to DPHY0 (4x2 mode only)<br>0b01: Map to DPHY1<br>0b10: Map to DPHY2<br>0b11: Map to DPHY3 (4x2 mode only) |
| MAP_DPHY_DEST_1 | 3:2  | CSI2 controller destination for MAP_SRC_1 (0x44F) and MAP_DST_0 (0x44E) mapping bitfields | 0b00: Map to DPHY0 (4x2 mode only)<br>0b01: Map to DPHY1<br>0b10: Map to DPHY2<br>0b11: Map to DPHY3 (4x2 mode only) |
| MAP_DPHY_DEST_0 | 1:0  | CSI2 controller destination for MAP_SRC_0 (0x44D) and MAP_DST_0 (0x44E) mapping bitfields | 0b00: Map to DPHY0 (4x2 mode only)<br>0b01: Map to DPHY1<br>0b10: Map to DPHY2<br>0b11: Map to DPHY3 (4x2 mode only) |

**MIPI TX46 (0x46E)**

| BIT          | 7                    | 6 | 5                    | 4 | 3                    | 2 | 1                    | 0 |
|--------------|----------------------|---|----------------------|---|----------------------|---|----------------------|---|
| <b>Field</b> | MAP_DPHY_DEST_7[1:0] |   | MAP_DPHY_DEST_6[1:0] |   | MAP_DPHY_DEST_5[1:0] |   | MAP_DPHY_DEST_4[1:0] |   |
| <b>Reset</b> | 0b00                 |   | 0b00                 |   | 0b00                 |   | 0b00                 |   |

|                    |             |             |             |             |
|--------------------|-------------|-------------|-------------|-------------|
| <b>Access Type</b> | Write, Read | Write, Read | Write, Read | Write, Read |
|--------------------|-------------|-------------|-------------|-------------|

| BITFIELD        | BITS | DESCRIPTION   | DECODE   |
|-----------------|------|---|--|
| MAP_DPHY_DEST_7 | 7:6  | CSI2 controller destination for MAP_SRC_7 (0x45B) and MAP_DST_0 (0x44E) mapping bitfields | 0b00: Map to DPHY0 (4x2 mode only)<br>0b01: Map to DPHY1<br>0b10: Map to DPHY2<br>0b11: Map to DPHY3 (4x2 mode only) |
| MAP_DPHY_DEST_6 | 5:4  | CSI2 controller destination for MAP_SRC_6 (0x459) and MAP_DST_0 (0x44E) mapping bitfields | 0b00: Map to DPHY0 (4x2 mode only)<br>0b01: Map to DPHY1<br>0b10: Map to DPHY2<br>0b11: Map to DPHY3 (4x2 mode only) |
| MAP_DPHY_DEST_5 | 3:2  | CSI2 controller destination for MAP_SRC_5 (0x457) and MAP_DST_0 (0x44E) mapping bitfields | 0b00: Map to DPHY0 (4x2 mode only)<br>0b01: Map to DPHY1<br>0b10: Map to DPHY2<br>0b11: Map to DPHY3 (4x2 mode only) |
| MAP_DPHY_DEST_4 | 1:0  | CSI2 controller destination for MAP_SRC_4 (0x455) and MAP_DST_0 (0x44E) mapping bitfields | 0b00: Map to DPHY0 (4x2 mode only)<br>0b01: Map to DPHY1<br>0b10: Map to DPHY2<br>0b11: Map to DPHY3 (4x2 mode only) |

**MIPI TX47 (0x46F)**

| BIT                | 7                     | 6 | 5                     | 4 | 3                    | 2 | 1                    | 0 |
|--------------------|-----------------------|---|-----------------------|---|----------------------|---|----------------------|---|
| <b>Field</b>       | MAP_DPHY_DEST_11[1:0] |   | MAP_DPHY_DEST_10[1:0] |   | MAP_DPHY_DEST_9[1:0] |   | MAP_DPHY_DEST_8[1:0] |   |
| <b>Reset</b>       | 0b00                  |   | 0b00                  |   | 0b00                 |   | 0b00                 |   |
| <b>Access Type</b> | Write, Read           |   | Write, Read           |   | Write, Read          |   | Write, Read          |   |

| BITFIELD         | BITS | DESCRIPTION  | DECODE   |
|------------------|------|--|--|
| MAP_DPHY_DEST_11 | 7:6  | CSI2 controller destination for MAP_SRC_11 (0x463) and MAP_DST_0 (0x44E) mapping bitfields | 0b00: Map to DPHY0 (4x2 mode only)<br>0b01: Map to DPHY1<br>0b10: Map to DPHY2<br>0b11: Map to DPHY3 (4x2 mode only) |
| MAP_DPHY_DEST_10 | 5:4  | CSI2 controller destination for MAP_SRC_10 (0x461) and MAP_DST_0 (0x44E) mapping bitfields | 0b00: Map to DPHY0 (4x2 mode only)<br>0b01: Map to DPHY1<br>0b10: Map to DPHY2<br>0b11: Map to DPHY3 (4x2 mode only) |
| MAP_DPHY_DEST_9  | 3:2  | CSI2 controller destination for MAP_SRC_9 (0x45F) and MAP_DST_0 (0x44E) mapping bitfields  | 0b00: Map to DPHY0 (4x2 mode only)<br>0b01: Map to DPHY1<br>0b10: Map to DPHY2<br>0b11: Map to DPHY3 (4x2 mode only) |
| MAP_DPHY_DEST_8  | 1:0  | CSI2 controller destination for MAP_SRC_8 (0x45D) and MAP_DST_0 (0x44E) mapping bitfields  | 0b00: Map to DPHY0 (4x2 mode only)<br>0b01: Map to DPHY1<br>0b10: Map to DPHY2<br>0b11: Map to DPHY3 (4x2 mode only) |

**MIPI TX48 (0x470)**

| BIT | 7 | 6 | 5 | 4 | 3 | 2 | 1 | 0 |
|-----|---|---|---|---|---|---|---|---|
|-----|---|---|---|---|---|---|---|---|

| Field       | MAP_DPHY_DEST_15[1:0] | MAP_DPHY_DEST_14[1:0] | MAP_DPHY_DEST_13[1:0] | MAP_DPHY_DEST_12[1:0] |
|-------------|-----------------------|-----------------------|-----------------------|-----------------------|
| Reset       | 0b00                  | 0b00                  | 0b00                  | 0b00                  |
| Access Type | Write, Read           | Write, Read           | Write, Read           | Write, Read           |

| BITFIELD         | BITS | DESCRIPTION  | DECODE   |
|------------------|------|--|--|
| MAP_DPHY_DEST_15 | 7:6  | CSI2 controller destination for MAP_SRC_15 (0x46B) and MAP_DST_0 (0x44E) mapping bitfields | 0b00: Map to DPHY0 (4x2 mode only)<br>0b01: Map to DPHY1<br>0b10: Map to DPHY2<br>0b11: Map to DPHY3 (4x2 mode only) |
| MAP_DPHY_DEST_14 | 5:4  | CSI2 controller destination for MAP_SRC_14 (0x469) and MAP_DST_0 (0x44E) mapping bitfields | 0b00: Map to DPHY0 (4x2 mode only)<br>0b01: Map to DPHY1<br>0b10: Map to DPHY2<br>0b11: Map to DPHY3 (4x2 mode only) |
| MAP_DPHY_DEST_13 | 3:2  | CSI2 controller destination for MAP_SRC_13 (0x467) and MAP_DST_0 (0x44E) mapping bitfields | 0b00: Map to DPHY0 (4x2 mode only)<br>0b01: Map to DPHY1<br>0b10: Map to DPHY2<br>0b11: Map to DPHY3 (4x2 mode only) |
| MAP_DPHY_DEST_12 | 1:0  | CSI2 controller destination for MAP_SRC_12 (0x465) and MAP_DST_0 (0x44E) mapping bitfields | 0b00: Map to DPHY0 (4x2 mode only)<br>0b01: Map to DPHY1<br>0b10: Map to DPHY2<br>0b11: Map to DPHY3 (4x2 mode only) |

**MIPI TX50 (0x472)**

| BIT         | 7                 | 6 | 5 | 4 | 3 | 2 | 1 | 0 |
|-------------|-------------------|---|---|---|---|---|---|---|
| Field       | SKEW_PER_SEL[7:0] |   |   |   |   |   |   |   |
| Reset       | 0x00              |   |   |   |   |   |   |   |
| Access Type | Write, Read       |   |   |   |   |   |   |   |

| BITFIELD     | BITS | DESCRIPTION   | DECODE   |
|--------------|------|---|--|
| SKEW_PER_SEL | 7:0  | <p>Periodic Deskew Select Register</p> <p>The register is split into three decode segments:<br/>bit[7] Select periodic deskew calibration for one or all virtual channels<br/>bits[6:5] Reserved<br/>bits[4:0] Virtual channel to generate periodic deskew calibration when only one channel is selected by bit 7</p> | 0b0XXXXXXX: Generate periodic calibration deskew calibration on all Virtual Channels<br>0b1XXX0000: Periodic deskew calibration generated by Virtual Channel 0<br>0b1XXX0001: Periodic deskew calibration generated by Virtual Channel 1<br>0b1XXX0010: Periodic deskew calibration generated by Virtual Channel 2<br>0b1XXX0011: Periodic deskew calibration generated by Virtual Channel 3<br>0b1XXX0100: Periodic deskew calibration generated by Virtual Channel 4<br>0b1XXX0101: Periodic deskew calibration generated by Virtual Channel 5<br>0b1XXX0110: Periodic deskew calibration generated by Virtual Channel 6<br>0b1XXX0111: Periodic deskew calibration generated by Virtual Channel 7<br>0b1XXX1000: Periodic deskew calibration generated by Virtual Channel 8<br>0b1XXX1001: Periodic deskew calibration generated by |

| BITFIELD | BITS | DESCRIPTION | DECODE  |
|----------|------|-------------|---|
|          |      |             | Virtual Channel 9<br>0b1XXX1010: Periodic deskew calibration generated by Virtual Channel 10<br>0b1XXX1011: Periodic deskew calibration generated by Virtual Channel 11<br>0b1XXX1100: Periodic deskew calibration generated by Virtual Channel 12<br>0b1XXX1101: Periodic deskew calibration generated by Virtual Channel 13<br>0b1XXX1110: Periodic deskew calibration generated by Virtual Channel 14<br>0b1XXX1111: Periodic deskew calibration generated by Virtual Channel 15 |

**MIPI TX51 (0x473)**

| BIT         | 7                      | 6 | 5             | 4           | 3             | 2            | 1             | 0           |
|-------------|------------------------|---|---------------|-------------|---------------|--------------|---------------|-------------|
| Field       | TUN_WAIT_VS_START[2:0] |   | ALT2_MEM_MAP8 | MODE_DT     | ALT_MEM_MAP10 | ALT_MEM_MAP8 | ALT_MEM_MAP12 |             |
| Reset       | 0b000                  |   | 0b0           | 0b0         | 0b0           | 0b0          | 0b0           | 0b0         |
| Access Type | Write, Read            |   | Write, Read   | Write, Read | Write, Read   | Write, Read  | Write, Read   | Write, Read |

| BITFIELD          | BITS | DESCRIPTION  | DECODE  |
|-------------------|------|--|---|
| TUN_WAIT_VS_START | 7:5  | Number of VS frames to wait before sending MIPI packet<br><br>Tunneling mode only.   | 0x0: No wait<br>Others: Number of frames to wait                        |
| ALT2_MEM_MAP8     | 4    | Alternative memory map enable for 8-bit DT. When set to 1, expects received video data to be packed into 24-bit in an alternative way by the serializer. | 0b0: Alternate memory map disabled<br>0b1: Alternate memory map enabled |
| MODE_DT           | 3    | MIPI Tx enable 24-bit packing of 8-bit MIPI UDP  | 0b0: Disabled<br>0b1: Enabled   |
| ALT_MEM_MAP10     | 2    | Alternative memory map enable for 10-bit DT (expect alternative bit packing by serializer)   | 0b0: Alternate memory map disabled<br>0b1: Alternate memory map enabled |
| ALT_MEM_MAP8      | 1    | Alternative memory map enable for 8-bit DT (expect alternative bit packing by serializer)  | 0b0: Alternate memory map disabled<br>0b1: Alternate memory map enabled |
| ALT_MEM_MAP12     | 0    | Alternative memory map enable for 12-bit DT (expect alternative bit packing by serializer)   | 0b0: Alternate memory map disabled<br>0b1: Alternate memory map enabled |

**MIPI TX52 (0x474)**

| BIT   | 7           | 6               | 5 | 4                     | 3 | 2              | 1        | 0      |
|-------|-------------|-----------------|---|-----------------------|---|----------------|----------|--------|
| Field | TUN_NO_CORR | DESKEW_TUN[1:0] |   | TUN_SER_LANE_NUM[1:0] |   | DESKEW_TUN_SRC | TUN_DEST | TUN_EN |

|                    |             |             |             |             |             |             |
|--------------------|-------------|-------------|-------------|-------------|-------------|-------------|
| <b>Reset</b>       | 0b0         | 0b00        | 0b01        | 0b0         | 0b0         | 0b0         |
| <b>Access Type</b> | Write, Read | Write, Read | Write, Read | Write, Read | Write, Read | Write, Read |

| BITFIELD         | BITS | DESCRIPTION  | DECODE   |
|------------------|------|--|--|
| TUN_NO_CORR      | 7    | Do not enable header error correction in tunneling mode  | 0b0: Tunneling error correction enabled<br>0b1: Tunneling error correction disabled  |
| DESKEW_TUN       | 6:5  | Deskew Mode for CSI2 Tunneling   | 0b00: Periodic deskew using deserializer DESKEW_PER register<br>0b01: Periodic deskew follows what Serializer receives with small offset adjustment by DESKEW_TUN_OFFSET.<br>0b10: Periodic deskew occurrence follows Serializer but width determined by register DESKEW_PER<br>0b11: Reserved |
| TUN_SER_LANE_NUM | 4:3  | Number of lanes in the serializer. Applies to CSI2 tunneling mode only, and CPHY mode only.                                    | 0b00: One data lane<br>0b01: Two data lanes<br>0b10: Three data lanes<br>0b11: Four data lanes   |
| DESKEW_TUN_SRC   | 2    | Tunneling Deskew Source Select   | 0b0: Pipe Y<br>0b1: Pipe Z   |
| TUN_DEST         | 1    | Tunneling Pipe Destination   | 0b0: MIPI PHY 1<br>0b1: MIPI PHY 2   |
| TUN_EN           | 0    | Tunneling Enable<br><br>The CFG pin sets this value initially, and further register writes to this register changes the value. | 0b0: Tunneling disabled<br>0b1: Tunneling enabled  |

**MIPI TX53 (0x475)**

|                    |                        |   |   |   |   |   |   |   |
|--------------------|------------------------|---|---|---|---|---|---|---|
| <b>BIT</b>         | 7                      | 6 | 5 | 4 | 3 | 2 | 1 | 0 |
| <b>Field</b>       | DESKEW_TUN_OFFSET[7:0] |   |   |   |   |   |   |   |
| <b>Reset</b>       | 0x00                   |   |   |   |   |   |   |   |
| <b>Access Type</b> | Write, Read            |   |   |   |   |   |   |   |

| BITFIELD          | BITS | DESCRIPTION                   |
|-------------------|------|-------------------------------|
| DESKEW_TUN_OFFSET | 7:0  | Tunneling Deskew Width Offset |

**MIPI TX54 (0x476)**

|              |                         |   |   |   |   |   |   |   |
|--------------|-------------------------|---|---|---|---|---|---|---|
| <b>BIT</b>   | 7                       | 6 | 5 | 4 | 3 | 2 | 1 | 0 |
| <b>Field</b> | TUN_PKT_START_ADDR[7:0] |   |   |   |   |   |   |   |
| <b>Reset</b> | 0x00                    |   |   |   |   |   |   |   |

|                    |             |
|--------------------|-------------|
| <b>Access Type</b> | Write, Read |
|--------------------|-------------|

| BITFIELD           | BITS | DESCRIPTION   | DECODE   |
|--------------------|------|---|--|
| TUN_PKT_START_ADDR | 7:0  | Specifies the start address of the long packet in Tunneling mode.<br><br>When 0, the long packet is sent out when the whole line is filled in the line memory. When not 0, the long packet begins when TUN_PKT_START_ADDR x 32 bytes are filled in the line memory. | 0xXX: Value x 32 bytes filled in memory is when long packet starts |

**MIPI TX55 (0x477)**

| BIT                | 7 | 6 | 5 | 4 | 3 | 2 | 1 | 0                  |
|--------------------|---|---|---|---|---|---|---|--------------------|
| <b>Field</b>       | - | - | - | - | - | - | - | TUN_NO_CORR_LENGTH |
| <b>Reset</b>       | - | - | - | - | - | - | - | 0b0                |
| <b>Access Type</b> | - | - | - | - | - | - | - | Write, Read        |

| BITFIELD           | BITS | DESCRIPTION  | DECODE  |
|--------------------|------|--|---|
| TUN_NO_CORR_LENGTH | 0    | Do not enable header error packet length correction in Tunneling mode. | 0b0: Tunneling error correction enabled<br>0b1: Tunneling error correction disabled |

**MIPI TX1 (0x481)**

| BIT                | 7           | 6 | 5 | 4 | 3 | 2 | 1 | 0 |
|--------------------|-------------|---|---|---|---|---|---|---|
| <b>Field</b>       | MODE[7:0]   |   |   |   |   |   |   |   |
| <b>Reset</b>       | 0x00        |   |   |   |   |   |   |   |
| <b>Access Type</b> | Write, Read |   |   |   |   |   |   |   |

| BITFIELD | BITS | DESCRIPTION  | DECODE  |
|----------|------|--------------|---|
| MODE     | 7:0  | MIPI Tx Mode | 0bXXXXXXXX0: Disable MIPI VS short packet counter<br>0bXXXXXXXX1: Enable MIPI VS short packet counter |

**MIPI TX2 (0x482)**

| BIT | 7 | 6 | 5 | 4 | 3 | 2 | 1 | 0 |
|-----|---|---|---|---|---|---|---|---|
|-----|---|---|---|---|---|---|---|---|

|                    |             |
|--------------------|-------------|
| <b>Field</b>       | STATUS[7:0] |
| <b>Reset</b>       | 0x00        |
| <b>Access Type</b> | Read Only   |

| BITFIELD | BITS | DESCRIPTION   | DECODE  |
|----------|------|---|---|
| STATUS   | 7:0  | <p>MIPI Tx Status</p> <p>The register is split into decode segments:</p> <p>bit[0] SYNC mode enable.</p> <p>bit[1] Video sync flag</p> <p>bit[2] Loss of video sync flag</p> <p>bit[3] Tunneling mode: DPHY ECC or CPHY header CRC error (correctable)</p> <p>bit[4] Tunneling mode: DPHY ECC or CPHY header CRC error (uncorrectable)</p> <p>bit[5] Tunneling mode: DPHY/CPHY data CRC error</p> | <p>0bXXXXXXXX0: SYNC mode disabled</p> <p>0bXXXXXXXX1: SYNC mode enabled</p> <p>0bXXXXXXXX0X: Video channels not in-sync</p> <p>0bXXXXXXXX1X: Video channels in-sync</p> <p>0bXXXXXXXXXX: No loss of video sync</p> <p>0bXXXXX1XX: Video sync lost after last read of this register or RESET.</p> <p>0bXXXXX0XXX: No tunneling ECC correctable error</p> <p>0bXXXXX1XXX: Tunneling ECC correctable error after last read of this register or RESET.</p> <p>0bXXX0XXXX: No tunneling ECC uncorrectable error</p> <p>0bXXX1XXXX: Tunneling ECC uncorrectable error after last read of this register or RESET.</p> <p>0bXX0XXXXX: No tunneling data CRC error</p> <p>0bXX1XXXXX: Tunneling data CRC error after last read of this register or RESET.</p> |

**MIPI TX3 (0x483)**

|                    |                  |          |          |          |          |          |          |          |
|--------------------|------------------|----------|----------|----------|----------|----------|----------|----------|
| <b>BIT</b>         | <b>7</b>         | <b>6</b> | <b>5</b> | <b>4</b> | <b>3</b> | <b>2</b> | <b>1</b> | <b>0</b> |
| <b>Field</b>       | DESKEW_INIT[7:0] |          |          |          |          |          |          |          |
| <b>Reset</b>       | 0x01             |          |          |          |          |          |          |          |
| <b>Access Type</b> | Write, Read      |          |          |          |          |          |          |          |

| BITFIELD    | BITS | DESCRIPTION   | DECODE  |
|-------------|------|---|---|
| DESKEW_INIT | 7:0  | <p>DPHY Deskew Initial Calibration Control</p> <p>The register is split into six decode segments:</p> <p>bit[7] Selects auto-initial deskew calibration on or off</p> <p>bit[6] Reserved</p> <p>bit[5] Any bit change initiates an initial calibration if bit 4 = 1</p> <p>bit[4] Selects manual initial on or off</p> <p>bit[3] Reserved</p> <p>bits[2:0] Selects initial deskew width</p> | <p>0bXXXXXXXX000: Reserved</p> <p>0bXXXXXXXX001: Initial deskew width = 2 x 32k UI - (t_lpx+t_hs_przero)[UI] - 16 UI</p> <p>0bXXXXXXXX010: Initial deskew width = 3 x 32k UI - (t_lpx+t_hs_przero)[UI] - 16 UI</p> <p>0bXXXXXXXX011: Initial deskew width = 4 x 32k UI - (t_lpx+t_hs_przero)[UI] - 16 UI</p> <p>0bXXXXXXXX100: Initial deskew width = 5 x 32k UI - (t_lpx+t_hs_przero)[UI] - 16 UI</p> <p>0bXXXXXXXX101: Initial deskew width = 6 x 32k UI - (t_lpx+t_hs_przero)[UI] - 16 UI</p> <p>0bXXXXXXXX110: Initial deskew width = 7 x 32k UI - (t_lpx+t_hs_przero)[UI] - 16 UI</p> <p>0bXXXXXXXX111: Initial deskew width = 8 x 32k UI - (t_lpx+t_hs_przero)[UI] - 16 UI</p> <p>0bXXXXX0XXX: Reserved</p> <p>0bXXXXX1XXX: Reserved</p> <p>0bXXX0XXXX: Manual initial off</p> <p>0bXXX1XXXX: Manual initial on</p> <p>0bXX0XXXXX: If bit 4 = 1, triggers one-time immediate initial skew calibration</p> <p>0bXX1XXXXX: If bit 4 = 1, triggers one-time immediate initial skew calibration</p> <p>0bX0XXXXXX: Reserved</p> <p>0bX1XXXXXX: Reserved</p> |

| BITFIELD | BITS | DESCRIPTION | DECODE   |
|----------|------|-------------|--|
|          |      |             | 0bXXXXXXXX: Auto initial deskew off<br>0b1XXXXXXXX: Auto initial deskew on |

**MIPI\_TX4 (0x484)**

| BIT         | 7               | 6 | 5 | 4 | 3 | 2 | 1 | 0 |
|-------------|-----------------|---|---|---|---|---|---|---|
| Field       | DESKEW_PER[7:0] |   |   |   |   |   |   |   |
| Reset       | 0x01            |   |   |   |   |   |   |   |
| Access Type | Write, Read     |   |   |   |   |   |   |   |

| BITFIELD   | BITS | DESCRIPTION  | DECODE   |
|------------|------|--|--|
| DESKEW_PER | 7:0  | <p>DPHY Periodic Deskew Calibration Control</p> <p>The register is split into four decode segments:<br/>                     bit[7] Selects periodic deskew calibration on or off<br/>                     bit[6] Selects generation on rising or falling edge of VS<br/>                     bits[5:3] Selects periodic interval<br/>                     bits[2:0] Selects periodic deskew width</p> | <p>0bXXXXX000: Reserved<br/>                     0bXXXXX001: Periodic deskew width = 2k UI - (t_lpx+t_hs_przero)[UI] - 16 UI<br/>                     0bXXXXX010: Periodic deskew width = 3k UI - (t_lpx+t_hs_przero)[UI] - 16 UI<br/>                     0bXXXXX011: Periodic deskew width = 4k UI - (t_lpx+t_hs_przero)[UI] - 16 UI<br/>                     0bXXXXX100: Periodic deskew width = 5k UI - (t_lpx+t_hs_przero)[UI] - 16 UI<br/>                     0bXXXXX101: Periodic deskew width = 6k UI - (t_lpx+t_hs_przero)[UI] - 16 UI<br/>                     0bXXXXX110: Periodic deskew width = 7k UI - (t_lpx+t_hs_przero)[UI] - 16 UI<br/>                     0bXXXXX111: Periodic deskew width = 8k UI - (t_lpx+t_hs_przero)[UI] - 16 UI<br/>                     0bXX000XXX: Periodic deskew calibration generated every frame<br/>                     0bXX001XXX: Periodic deskew calibration generated every 2 frames<br/>                     0bXX010XXX: Periodic deskew calibration generated every 4 frames<br/>                     0bXX011XXX: Periodic deskew calibration generated every 8 frames<br/>                     0bXX100XXX: Periodic deskew calibration generated every 16 frames<br/>                     0bXX101XXX: Periodic deskew calibration generated every 32 frames<br/>                     0bXX110XXX: Periodic deskew calibration generated every 64 frames<br/>                     0bXX111XXX: Periodic deskew calibration generated every 128 frames<br/>                     0bX0XXXXXX: Periodic deskew calibration generated at rising edge of VS<br/>                     0bX1XXXXXX: Periodic deskew calibration generated at falling edge of VS<br/>                     0b0XXXXXXX: Periodic deskew calibration off<br/>                     0b1XXXXXXX: Periodic deskew calibration on</p> |

**MIPI\_TX7 (0x487)**

| BIT   | 7                | 6 | 5 | 4 | 3 | 2 | 1 | 0 |
|-------|------------------|---|---|---|---|---|---|---|
| Field | CSI2_TX_GAP[7:0] |   |   |   |   |   |   |   |

|                    |             |
|--------------------|-------------|
| <b>Reset</b>       | 0x1C        |
| <b>Access Type</b> | Write, Read |

| <b>BITFIELD</b> | <b>BITS</b> | <b>DESCRIPTION</b>   | <b>DECODE</b>                    |
|-----------------|-------------|--|----------------------------------|
| CSI2_TX_GAP     | 7:0         | Number of MIPI byte clocks to wait after the HS clock has entered LP before enabling it again for the next transmission. | 0xXX: Number of MIPI byte clocks |

**MIPI TX10 (0x48A)**

| <b>BIT</b>         | <b>7</b>           | <b>6</b> | <b>5</b>     | <b>4</b> | <b>3</b>    | <b>2</b> | <b>1</b> | <b>0</b> |
|--------------------|--------------------|----------|--------------|----------|-------------|----------|----------|----------|
| <b>Field</b>       | CSI2_LANE_CNT[1:0] |          | CSI2_CPHY_EN | –        | CSI_VCX_EN  | –        | –        | –        |
| <b>Reset</b>       | 0b11               |          | 0b0          | –        | 0b0         | –        | –        | –        |
| <b>Access Type</b> | Write, Read        |          | Write, Read  | –        | Write, Read | –        | –        | –        |

| <b>BITFIELD</b> | <b>BITS</b> | <b>DESCRIPTION</b>            | <b>DECODE</b>  |
|-----------------|-------------|-------------------------------|--|
| CSI2_LANE_CNT   | 7:6         | Set number of MIPI data lanes | 0b00: One data lane<br>0b01: Two data lanes<br>0b10: Three data lanes<br>0b11: Four data lanes |
| CSI2_CPHY_EN    | 5           | Enable CPHY                   | 0b0: CPHY disabled<br>0b1: CPHY enabled  |
| CSI_VCX_EN      | 3           | Enable VC Extension           | 0b0: Disable VC extension<br>0x1: Enable VC extension  |

**MIPI TX11 (0x48B)**

| <b>BIT</b>         | <b>7</b>      | <b>6</b> | <b>5</b> | <b>4</b> | <b>3</b> | <b>2</b> | <b>1</b> | <b>0</b> |
|--------------------|---------------|----------|----------|----------|----------|----------|----------|----------|
| <b>Field</b>       | MAP_EN_L[7:0] |          |          |          |          |          |          |          |
| <b>Reset</b>       | 0x00          |          |          |          |          |          |          |          |
| <b>Access Type</b> | Write, Read   |          |          |          |          |          |          |          |

| <b>BITFIELD</b> | <b>BITS</b> | <b>DESCRIPTION</b>  | <b>DECODE</b>  |
|-----------------|-------------|---|--|
| MAP_EN_L        | 7:0         | Mapping Enable Low Byte [7:0]<br><br>Each bit enables one of eight mapping and distribution entries (defined in MAP_SRC_x, MAP_DST_x, and MAP_DPHY_DST_x) for the current video stream. | 0xX1: Enable MAP_SRC_0 (0x48D) and MAP_DST_0 (0x48E) bitfields<br>0xX2: Enable MAP_SRC_1 (0x48F) and MAP_DST_1 (0x490) bitfields<br>0xX4: Enable MAP_SRC_2 (0x491) and MAP_DST_2 (0x492) bitfields<br>0xX8: Enable MAP_SRC_3 (0x493) and MAP_DST_3 (0x494) bitfields<br>0x1X: Enable MAP_SRC_4 (0x495) and MAP_DST_4 (0x496) bitfields |

| BITFIELD | BITS | DESCRIPTION   | DECODE  |
|----------|------|---|---|
|          |      | <p>Non-matched virtual channel (VC) and data types (DT) pass to the corresponding CSI2 controller.</p> <p>In video pixel mode, this is use to change any VC, DT, CSI2 controller destination.</p> | <p>0x2X: Enable MAP_SRC_5 (0x497) and MAP_DST_5 (0x498) bitfields</p> <p>0x4X: Enable MAP_SRC_6 and (0x499) and MAX_DST_6 (0x49A) bitfields</p> <p>0x8X: Enable MAP_SRC_7 (0x49B) and MAP_DST_7 (0x49C) bitfields</p> |

**MIPI TX12 (0x48C)**

| BIT         | 7             | 6 | 5 | 4 | 3 | 2 | 1 | 0 |
|-------------|---------------|---|---|---|---|---|---|---|
| Field       | MAP_EN_H[7:0] |   |   |   |   |   |   |   |
| Reset       | 0x00          |   |   |   |   |   |   |   |
| Access Type | Write, Read   |   |   |   |   |   |   |   |

| BITFIELD | BITS | DESCRIPTION  | DECODE   |
|----------|------|--|--|
| MAP_EN_H | 7:0  | <p>Mapping Enable High Byte [15:8]</p> <p>Each bit enables one of eight mapping and distribution entries (defined in MAP_SRC_x, MAP_DST_x, and MAP_DPHY_DST_x) for the current video stream.</p> <p>Non-matched virtual channel (VC) and data types (DT) pass to the corresponding CSI2 controller.</p> <p>In video pixel mode, this is use to change any VC, DT, CSI2 controller destination.</p> | <p>0xX1: Enable MAP_SRC_8 (0x49D) and MAP_DST_8 (0x49E) bitfields</p> <p>0xX2: Enable MAP_SRC_9 (0x49F) and MAP_DST_9 (0x4A0) bitfields</p> <p>0xX4: Enable MAP_SRC_10 (0x4A1) and MAP_DST_10 (0x4A2) bitfields</p> <p>0xX8: Enable MAP_SRC_11 (0x4A3) and MAP_DST_11 (0x4A4) bitfields</p> <p>0x1X: Enable MAP_SRC_12 (0x4A5) and MAP_DST_12 (0x4A6) bitfields</p> <p>0x2X: Enable MAP_SRC_13 (0x4A7) and MAP_DST_13 (0x4A8) bitfields</p> <p>0x4X: Enable MAP_SRC_14 (0x4A9) and MAP_DST_14 (0x4AA) bitfields</p> <p>0x8X: Enable MAP_SRC_15 (0x4AB) and MAP_DST_15 (x4AC) bitfields</p> |

**MIPI TX13 (0x48D)**

| BIT         | 7              | 6 | 5 | 4 | 3 | 2 | 1 | 0 |
|-------------|----------------|---|---|---|---|---|---|---|
| Field       | MAP_SRC_0[7:0] |   |   |   |   |   |   |   |
| Reset       | 0x00           |   |   |   |   |   |   |   |
| Access Type | Write, Read    |   |   |   |   |   |   |   |

| BITFIELD  | BITS | DESCRIPTION   | DECODE                           |
|-----------|------|---|----------------------------------|
| MAP_SRC_0 | 7:0  | <p>Mapping Source Register 0</p> <p>The register is split into two decode segments:</p> | 0xXX: VC and DT source for map 0 |

| BITFIELD | BITS | DESCRIPTION  | DECODE |
|----------|------|--|--------|
|          |      | bits[7:6] VC - Virtual channel<br>bits[5:0] DT - Data type |        |

**MIPI TX14 (0x48E)**

| BIT         | 7              | 6 | 5 | 4 | 3 | 2 | 1 | 0 |
|-------------|----------------|---|---|---|---|---|---|---|
| Field       | MAP_DST_0[7:0] |   |   |   |   |   |   |   |
| Reset       | 0x00           |   |   |   |   |   |   |   |
| Access Type | Write, Read    |   |   |   |   |   |   |   |

| BITFIELD  | BITS | DESCRIPTION   | DECODE                                |
|-----------|------|---|---------------------------------------|
| MAP_DST_0 | 7:0  | Mapping Destination Register 0<br><br>The register is split into two decode segments:<br>bits[7:6] VC - Virtual channel<br>bits[5:0] DT - Data type | 0xXX: VC and DT destination for map 0 |

**MIPI TX15 (0x48F)**

| BIT         | 7              | 6 | 5 | 4 | 3 | 2 | 1 | 0 |
|-------------|----------------|---|---|---|---|---|---|---|
| Field       | MAP_SRC_1[7:0] |   |   |   |   |   |   |   |
| Reset       | 0x00           |   |   |   |   |   |   |   |
| Access Type | Write, Read    |   |   |   |   |   |   |   |

| BITFIELD  | BITS | DESCRIPTION  | DECODE                           |
|-----------|------|--|----------------------------------|
| MAP_SRC_1 | 7:0  | Mapping Source Register 1<br><br>The register is split into two decode segments:<br>bits[7:6] VC - Virtual channel<br>bits[5:0] DT - Data type | 0xXX: VC and DT source for map 1 |

**MIPI TX16 (0x490)**

| BIT   | 7              | 6 | 5 | 4 | 3 | 2 | 1 | 0 |
|-------|----------------|---|---|---|---|---|---|---|
| Field | MAP_DST_1[7:0] |   |   |   |   |   |   |   |
| Reset | 0x00           |   |   |   |   |   |   |   |

|                    |             |
|--------------------|-------------|
| <b>Access Type</b> | Write, Read |
|--------------------|-------------|

| <b>BITFIELD</b> | <b>BITS</b> | <b>DESCRIPTION</b>  | <b>DECODE</b>                         |
|-----------------|-------------|---|---------------------------------------|
| MAP_DST_1       | 7:0         | Mapping Destination Register 1<br>The register is split into two decode segments:<br>bits[7:6] VC - Virtual channel<br>bits[5:0] DT - Data type | 0xXX: VC and DT destination for map 1 |

**MIPI TX17 (0x491)**

| <b>BIT</b>         | <b>7</b>       | <b>6</b> | <b>5</b> | <b>4</b> | <b>3</b> | <b>2</b> | <b>1</b> | <b>0</b> |
|--------------------|----------------|----------|----------|----------|----------|----------|----------|----------|
| <b>Field</b>       | MAP_SRC_2[7:0] |          |          |          |          |          |          |          |
| <b>Reset</b>       | 0x00           |          |          |          |          |          |          |          |
| <b>Access Type</b> | Write, Read    |          |          |          |          |          |          |          |

| <b>BITFIELD</b> | <b>BITS</b> | <b>DESCRIPTION</b>   | <b>DECODE</b>                    |
|-----------------|-------------|--|----------------------------------|
| MAP_SRC_2       | 7:0         | Mapping Source Register 2<br>The register is split into two decode segments:<br>bits[7:6] VC - Virtual channel<br>bits[5:0] DT - Data type | 0xXX: VC and DT source for map 2 |

**MIPI TX18 (0x492)**

| <b>BIT</b>         | <b>7</b>       | <b>6</b> | <b>5</b> | <b>4</b> | <b>3</b> | <b>2</b> | <b>1</b> | <b>0</b> |
|--------------------|----------------|----------|----------|----------|----------|----------|----------|----------|
| <b>Field</b>       | MAP_DST_2[7:0] |          |          |          |          |          |          |          |
| <b>Reset</b>       | 0x00           |          |          |          |          |          |          |          |
| <b>Access Type</b> | Write, Read    |          |          |          |          |          |          |          |

| <b>BITFIELD</b> | <b>BITS</b> | <b>DESCRIPTION</b>  | <b>DECODE</b>                         |
|-----------------|-------------|---|---------------------------------------|
| MAP_DST_2       | 7:0         | Mapping Destination Register 2<br>The register is split into two decode segments:<br>bits[7:6] VC - Virtual channel<br>bits[5:0] DT - Data type | 0xXX: VC and DT destination for map 2 |

**MIPI TX19 (0x493)**

|                    |                |          |          |          |          |          |          |          |
|--------------------|----------------|----------|----------|----------|----------|----------|----------|----------|
| <b>BIT</b>         | <b>7</b>       | <b>6</b> | <b>5</b> | <b>4</b> | <b>3</b> | <b>2</b> | <b>1</b> | <b>0</b> |
| <b>Field</b>       | MAP_SRC_3[7:0] |          |          |          |          |          |          |          |
| <b>Reset</b>       | 0x00           |          |          |          |          |          |          |          |
| <b>Access Type</b> | Write, Read    |          |          |          |          |          |          |          |

| <b>BITFIELD</b> | <b>BITS</b> | <b>DESCRIPTION</b>   | <b>DECODE</b>                    |
|-----------------|-------------|--|----------------------------------|
| MAP_SRC_3       | 7:0         | Mapping Source Register 3<br>The register is split into two decode segments:<br>bits[7:6] VC - Virtual channel<br>bits[5:0] DT - Data type | 0xXX: VC and DT source for map 3 |

**MIPI TX20 (0x494)**

|                    |                |          |          |          |          |          |          |          |
|--------------------|----------------|----------|----------|----------|----------|----------|----------|----------|
| <b>BIT</b>         | <b>7</b>       | <b>6</b> | <b>5</b> | <b>4</b> | <b>3</b> | <b>2</b> | <b>1</b> | <b>0</b> |
| <b>Field</b>       | MAP_DST_3[7:0] |          |          |          |          |          |          |          |
| <b>Reset</b>       | 0x00           |          |          |          |          |          |          |          |
| <b>Access Type</b> | Write, Read    |          |          |          |          |          |          |          |

| <b>BITFIELD</b> | <b>BITS</b> | <b>DESCRIPTION</b>  | <b>DECODE</b>                         |
|-----------------|-------------|---|---------------------------------------|
| MAP_DST_3       | 7:0         | Mapping Destination Register 3<br>The register is split into two decode segments:<br>bits[7:6] VC - Virtual channel<br>bits[5:0] DT - Data type | 0xXX: VC and DT destination for map 3 |

**MIPI TX21 (0x495)**

|                    |                |          |          |          |          |          |          |          |
|--------------------|----------------|----------|----------|----------|----------|----------|----------|----------|
| <b>BIT</b>         | <b>7</b>       | <b>6</b> | <b>5</b> | <b>4</b> | <b>3</b> | <b>2</b> | <b>1</b> | <b>0</b> |
| <b>Field</b>       | MAP_SRC_4[7:0] |          |          |          |          |          |          |          |
| <b>Reset</b>       | 0x00           |          |          |          |          |          |          |          |
| <b>Access Type</b> | Write, Read    |          |          |          |          |          |          |          |

| BITFIELD  | BITS | DESCRIPTION  | DECODE                           |
|-----------|------|--|----------------------------------|
| MAP_SRC_4 | 7:0  | Mapping Source Register 4<br>The register is split into two decode segments:<br>bits[7:6] VC - Virtual channel<br>bits[5:0] DT - Data type | 0xXX: VC and DT source for map 4 |

**MIPI\_TX22 (0x496)**

| BIT         | 7              | 6 | 5 | 4 | 3 | 2 | 1 | 0 |
|-------------|----------------|---|---|---|---|---|---|---|
| Field       | MAP_DST_4[7:0] |   |   |   |   |   |   |   |
| Reset       | 0x00           |   |   |   |   |   |   |   |
| Access Type | Write, Read    |   |   |   |   |   |   |   |

| BITFIELD  | BITS | DESCRIPTION   | DECODE                                |
|-----------|------|---|---------------------------------------|
| MAP_DST_4 | 7:0  | Mapping Destination Register 4<br>The register is split into two decode segments:<br>bits[7:6] VC - Virtual channel<br>bits[5:0] DT - Data type | 0xXX: VC and DT destination for map 4 |

**MIPI\_TX23 (0x497)**

| BIT         | 7              | 6 | 5 | 4 | 3 | 2 | 1 | 0 |
|-------------|----------------|---|---|---|---|---|---|---|
| Field       | MAP_SRC_5[7:0] |   |   |   |   |   |   |   |
| Reset       | 0x00           |   |   |   |   |   |   |   |
| Access Type | Write, Read    |   |   |   |   |   |   |   |

| BITFIELD  | BITS | DESCRIPTION  | DECODE                           |
|-----------|------|--|----------------------------------|
| MAP_SRC_5 | 7:0  | Mapping Source Register 5<br>The register is split into two decode segments:<br>bits[7:6] VC - Virtual channel<br>bits[5:0] DT - Data type | 0xXX: VC and DT source for map 5 |

**MIPI\_TX24 (0x498)**

| BIT | 7 | 6 | 5 | 4 | 3 | 2 | 1 | 0 |
|-----|---|---|---|---|---|---|---|---|
|-----|---|---|---|---|---|---|---|---|

|                    |                |
|--------------------|----------------|
| <b>Field</b>       | MAP_DST_5[7:0] |
| <b>Reset</b>       | 0x00           |
| <b>Access Type</b> | Write, Read    |

| <b>BITFIELD</b> | <b>BITS</b> | <b>DESCRIPTION</b>  | <b>DECODE</b>                         |
|-----------------|-------------|---|---------------------------------------|
| MAP_DST_5       | 7:0         | Mapping Destination Register 5<br><br>The register is split into two decode segments:<br>bits[7:6] VC - Virtual channel<br>bits[5:0] DT - Data type | 0xXX: VC and DT destination for map 5 |

**MIPI TX25 (0x499)**

| <b>BIT</b>         | <b>7</b>       | <b>6</b> | <b>5</b> | <b>4</b> | <b>3</b> | <b>2</b> | <b>1</b> | <b>0</b> |
|--------------------|----------------|----------|----------|----------|----------|----------|----------|----------|
| <b>Field</b>       | MAP_SRC_6[7:0] |          |          |          |          |          |          |          |
| <b>Reset</b>       | 0x00           |          |          |          |          |          |          |          |
| <b>Access Type</b> | Write, Read    |          |          |          |          |          |          |          |

| <b>BITFIELD</b> | <b>BITS</b> | <b>DESCRIPTION</b>   | <b>DECODE</b>                    |
|-----------------|-------------|--|----------------------------------|
| MAP_SRC_6       | 7:0         | Mapping Source Register 6<br><br>The register is split into two decode segments:<br>bits[7:6] VC - Virtual channel<br>bits[5:0] DT - Data type | 0xXX: VC and DT source for map 6 |

**MIPI TX26 (0x49A)**

| <b>BIT</b>         | <b>7</b>       | <b>6</b> | <b>5</b> | <b>4</b> | <b>3</b> | <b>2</b> | <b>1</b> | <b>0</b> |
|--------------------|----------------|----------|----------|----------|----------|----------|----------|----------|
| <b>Field</b>       | MAP_DST_6[7:0] |          |          |          |          |          |          |          |
| <b>Reset</b>       | 0x00           |          |          |          |          |          |          |          |
| <b>Access Type</b> | Write, Read    |          |          |          |          |          |          |          |

| <b>BITFIELD</b> | <b>BITS</b> | <b>DESCRIPTION</b>  | <b>DECODE</b>                         |
|-----------------|-------------|---|---------------------------------------|
| MAP_DST_6       | 7:0         | Mapping Destination Register 6<br><br>The register is split into two decode segments: | 0xXX: VC and DT destination for map 6 |

| BITFIELD | BITS | DESCRIPTION  | DECODE |
|----------|------|--|--------|
|          |      | bits[7:6] VC - Virtual channel<br>bits[5:0] DT - Data type |        |

**MIPI TX27 (0x49B)**

| BIT         | 7              | 6 | 5 | 4 | 3 | 2 | 1 | 0 |
|-------------|----------------|---|---|---|---|---|---|---|
| Field       | MAP_SRC_7[7:0] |   |   |   |   |   |   |   |
| Reset       | 0x00           |   |   |   |   |   |   |   |
| Access Type | Write, Read    |   |   |   |   |   |   |   |

| BITFIELD  | BITS | DESCRIPTION  | DECODE                           |
|-----------|------|--|----------------------------------|
| MAP_SRC_7 | 7:0  | Mapping Source Register 7<br><br>The register is split into two decode segments:<br>bits[7:6] VC - Virtual channel<br>bits[5:0] DT - Data type | 0xXX: VC and DT source for map 7 |

**MIPI TX28 (0x49C)**

| BIT         | 7              | 6 | 5 | 4 | 3 | 2 | 1 | 0 |
|-------------|----------------|---|---|---|---|---|---|---|
| Field       | MAP_DST_7[7:0] |   |   |   |   |   |   |   |
| Reset       | 0x00           |   |   |   |   |   |   |   |
| Access Type | Write, Read    |   |   |   |   |   |   |   |

| BITFIELD  | BITS | DESCRIPTION   | DECODE                                |
|-----------|------|---|---------------------------------------|
| MAP_DST_7 | 7:0  | Mapping Destination Register 7<br><br>The register is split into two decode segments:<br>bits[7:6] VC - Virtual channel<br>bits[5:0] DT - Data type | 0xXX: VC and DT destination for map 7 |

**MIPI TX29 (0x49D)**

| BIT   | 7              | 6 | 5 | 4 | 3 | 2 | 1 | 0 |
|-------|----------------|---|---|---|---|---|---|---|
| Field | MAP_SRC_8[7:0] |   |   |   |   |   |   |   |
| Reset | 0x00           |   |   |   |   |   |   |   |

|                    |             |
|--------------------|-------------|
| <b>Access Type</b> | Write, Read |
|--------------------|-------------|

| <b>BITFIELD</b> | <b>BITS</b> | <b>DESCRIPTION</b>   | <b>DECODE</b>                    |
|-----------------|-------------|--|----------------------------------|
| MAP_SRC_8       | 7:0         | Mapping Source Register 8<br>The register is split into two decode segments:<br>bits[7:6] VC - Virtual channel<br>bits[5:0] DT - Data type | 0xXX: VC and DT source for map 8 |

**MIPI TX30 (0x49E)**

| <b>BIT</b>         | <b>7</b>       | <b>6</b> | <b>5</b> | <b>4</b> | <b>3</b> | <b>2</b> | <b>1</b> | <b>0</b> |
|--------------------|----------------|----------|----------|----------|----------|----------|----------|----------|
| <b>Field</b>       | MAP_DST_8[7:0] |          |          |          |          |          |          |          |
| <b>Reset</b>       | 0x00           |          |          |          |          |          |          |          |
| <b>Access Type</b> | Write, Read    |          |          |          |          |          |          |          |

| <b>BITFIELD</b> | <b>BITS</b> | <b>DESCRIPTION</b>  | <b>DECODE</b>                         |
|-----------------|-------------|---|---------------------------------------|
| MAP_DST_8       | 7:0         | Mapping Destination Register 8<br>The register is split into two decode segments:<br>bits[7:6] VC - Virtual channel<br>bits[5:0] DT - Data type | 0xXX: VC and DT destination for map 8 |

**MIPI TX31 (0x49F)**

| <b>BIT</b>         | <b>7</b>       | <b>6</b> | <b>5</b> | <b>4</b> | <b>3</b> | <b>2</b> | <b>1</b> | <b>0</b> |
|--------------------|----------------|----------|----------|----------|----------|----------|----------|----------|
| <b>Field</b>       | MAP_SRC_9[7:0] |          |          |          |          |          |          |          |
| <b>Reset</b>       | 0x00           |          |          |          |          |          |          |          |
| <b>Access Type</b> | Write, Read    |          |          |          |          |          |          |          |

| <b>BITFIELD</b> | <b>BITS</b> | <b>DESCRIPTION</b>   | <b>DECODE</b>                    |
|-----------------|-------------|--|----------------------------------|
| MAP_SRC_9       | 7:0         | Mapping Source Register 9<br>The register is split into two decode segments:<br>bits[7:6] VC - Virtual channel<br>bits[5:0] DT - Data type | 0xXX: VC and DT source for map 9 |

**MIPI TX32 (0x4A0)**

|                    |                |          |          |          |          |          |          |          |
|--------------------|----------------|----------|----------|----------|----------|----------|----------|----------|
| <b>BIT</b>         | <b>7</b>       | <b>6</b> | <b>5</b> | <b>4</b> | <b>3</b> | <b>2</b> | <b>1</b> | <b>0</b> |
| <b>Field</b>       | MAP_DST_9[7:0] |          |          |          |          |          |          |          |
| <b>Reset</b>       | 0x00           |          |          |          |          |          |          |          |
| <b>Access Type</b> | Write, Read    |          |          |          |          |          |          |          |

| <b>BITFIELD</b> | <b>BITS</b> | <b>DESCRIPTION</b>  | <b>DECODE</b>                         |
|-----------------|-------------|---|---------------------------------------|
| MAP_DST_9       | 7:0         | Mapping Destination Register 9<br><br>The register is split into two decode segments:<br>bits[7:6] VC - Virtual channel<br>bits[5:0] DT - Data type | 0xXX: VC and DT destination for map 9 |

**MIPI TX33 (0x4A1)**

|                    |                 |          |          |          |          |          |          |          |
|--------------------|-----------------|----------|----------|----------|----------|----------|----------|----------|
| <b>BIT</b>         | <b>7</b>        | <b>6</b> | <b>5</b> | <b>4</b> | <b>3</b> | <b>2</b> | <b>1</b> | <b>0</b> |
| <b>Field</b>       | MAP_SRC_10[7:0] |          |          |          |          |          |          |          |
| <b>Reset</b>       | 0x00            |          |          |          |          |          |          |          |
| <b>Access Type</b> | Write, Read     |          |          |          |          |          |          |          |

| <b>BITFIELD</b> | <b>BITS</b> | <b>DESCRIPTION</b>  | <b>DECODE</b>                     |
|-----------------|-------------|---|-----------------------------------|
| MAP_SRC_10      | 7:0         | Mapping Source Register 10<br><br>The register is split into two decode segments:<br>bits[7:6] VC - Virtual channel<br>bits[5:0] DT - Data type | 0xXX: VC and DT source for map 10 |

**MIPI TX34 (0x4A2)**

|                    |                 |          |          |          |          |          |          |          |
|--------------------|-----------------|----------|----------|----------|----------|----------|----------|----------|
| <b>BIT</b>         | <b>7</b>        | <b>6</b> | <b>5</b> | <b>4</b> | <b>3</b> | <b>2</b> | <b>1</b> | <b>0</b> |
| <b>Field</b>       | MAP_DST_10[7:0] |          |          |          |          |          |          |          |
| <b>Reset</b>       | 0x00            |          |          |          |          |          |          |          |
| <b>Access Type</b> | Write, Read     |          |          |          |          |          |          |          |

| BITFIELD   | BITS | DESCRIPTION  | DECODE                                 |
|------------|------|--|--|
| MAP_DST_10 | 7:0  | Mapping Destination Register 10<br>The register is split into two decode segments:<br>bits[7:6] VC - Virtual channel<br>bits[5:0] DT - Data type | 0xXX: VC and DT destination for map 10 |

**MIPI\_TX35 (0x4A3)**

| BIT         | 7               | 6 | 5 | 4 | 3 | 2 | 1 | 0 |
|-------------|-----------------|---|---|---|---|---|---|---|
| Field       | MAP_SRC_11[7:0] |   |   |   |   |   |   |   |
| Reset       | 0x00            |   |   |   |   |   |   |   |
| Access Type | Write, Read     |   |   |   |   |   |   |   |

| BITFIELD   | BITS | DESCRIPTION   | DECODE                            |
|------------|------|---|-----------------------------------|
| MAP_SRC_11 | 7:0  | Mapping Source Register 11<br>The register is split into two decode segments:<br>bits[7:6] VC - Virtual channel<br>bits[5:0] DT - Data type | 0xXX: VC and DT source for map 11 |

**MIPI\_TX36 (0x4A4)**

| BIT         | 7               | 6 | 5 | 4 | 3 | 2 | 1 | 0 |
|-------------|-----------------|---|---|---|---|---|---|---|
| Field       | MAP_DST_11[7:0] |   |   |   |   |   |   |   |
| Reset       | 0x00            |   |   |   |   |   |   |   |
| Access Type | Write, Read     |   |   |   |   |   |   |   |

| BITFIELD   | BITS | DESCRIPTION  | DECODE                                 |
|------------|------|--|--|
| MAP_DST_11 | 7:0  | Mapping Destination Register 11<br>The register is split into two decode segments:<br>bits[7:6] VC - Virtual channel<br>bits[5:0] DT - Data type | 0xXX: VC and DT destination for map 11 |

**MIPI\_TX37 (0x4A5)**

| BIT | 7 | 6 | 5 | 4 | 3 | 2 | 1 | 0 |
|-----|---|---|---|---|---|---|---|---|
|-----|---|---|---|---|---|---|---|---|

|                    |                 |
|--------------------|-----------------|
| <b>Field</b>       | MAP_SRC_12[7:0] |
| <b>Reset</b>       | 0x00            |
| <b>Access Type</b> | Write, Read     |

| <b>BITFIELD</b> | <b>BITS</b> | <b>DESCRIPTION</b>  | <b>DECODE</b>                     |
|-----------------|-------------|---|-----------------------------------|
| MAP_SRC_12      | 7:0         | Mapping Source Register 12<br><br>The register is split into two decode segments:<br>bits[7:6] VC - Virtual channel<br>bits[5:0] DT - Data type | 0xXX: VC and DT source for map 12 |

**MIPI TX38 (0x4A6)**

|                    |                 |          |          |          |          |          |          |          |
|--------------------|-----------------|----------|----------|----------|----------|----------|----------|----------|
| <b>BIT</b>         | <b>7</b>        | <b>6</b> | <b>5</b> | <b>4</b> | <b>3</b> | <b>2</b> | <b>1</b> | <b>0</b> |
| <b>Field</b>       | MAP_DST_12[7:0] |          |          |          |          |          |          |          |
| <b>Reset</b>       | 0x00            |          |          |          |          |          |          |          |
| <b>Access Type</b> | Write, Read     |          |          |          |          |          |          |          |

| <b>BITFIELD</b> | <b>BITS</b> | <b>DESCRIPTION</b>   | <b>DECODE</b>                          |
|-----------------|-------------|--|--|
| MAP_DST_12      | 7:0         | Mapping Destination Register 12<br><br>The register is split into two decode segments:<br>bits[7:6] VC - Virtual channel<br>bits[5:0] DT - Data type | 0xXX: VC and DT destination for map 12 |

**MIPI TX39 (0x4A7)**

|                    |                 |          |          |          |          |          |          |          |
|--------------------|-----------------|----------|----------|----------|----------|----------|----------|----------|
| <b>BIT</b>         | <b>7</b>        | <b>6</b> | <b>5</b> | <b>4</b> | <b>3</b> | <b>2</b> | <b>1</b> | <b>0</b> |
| <b>Field</b>       | MAP_SRC_13[7:0] |          |          |          |          |          |          |          |
| <b>Reset</b>       | 0x00            |          |          |          |          |          |          |          |
| <b>Access Type</b> | Write, Read     |          |          |          |          |          |          |          |

| <b>BITFIELD</b> | <b>BITS</b> | <b>DESCRIPTION</b>  | <b>DECODE</b>                     |
|-----------------|-------------|---|-----------------------------------|
| MAP_SRC_13      | 7:0         | Mapping Source Register 13<br><br>The register is split into two decode segments: | 0xXX: VC and DT source for map 13 |

| BITFIELD | BITS | DESCRIPTION  | DECODE |
|----------|------|--|--------|
|          |      | bits[7:6] VC - Virtual channel<br>bits[5:0] DT - Data type |        |

**MIPI TX40 (0x4A8)**

| BIT         | 7               | 6 | 5 | 4 | 3 | 2 | 1 | 0 |
|-------------|-----------------|---|---|---|---|---|---|---|
| Field       | MAP_DST_13[7:0] |   |   |   |   |   |   |   |
| Reset       | 0x00            |   |   |   |   |   |   |   |
| Access Type | Write, Read     |   |   |   |   |   |   |   |

| BITFIELD   | BITS | DESCRIPTION  | DECODE                                 |
|------------|------|--|--|
| MAP_DST_13 | 7:0  | Mapping Destination Register 13<br><br>The register is split into two decode segments:<br>bits[7:6] VC - Virtual channel<br>bits[5:0] DT - Data type | 0xXX: VC and DT destination for map 13 |

**MIPI TX41 (0x4A9)**

| BIT         | 7               | 6 | 5 | 4 | 3 | 2 | 1 | 0 |
|-------------|-----------------|---|---|---|---|---|---|---|
| Field       | MAP_SRC_14[7:0] |   |   |   |   |   |   |   |
| Reset       | 0x00            |   |   |   |   |   |   |   |
| Access Type | Write, Read     |   |   |   |   |   |   |   |

| BITFIELD   | BITS | DESCRIPTION   | DECODE                            |
|------------|------|---|-----------------------------------|
| MAP_SRC_14 | 7:0  | Mapping Source Register 14<br><br>The register is split into two decode segments:<br>bits[7:6] VC - Virtual channel<br>bits[5:0] DT - Data type | 0xXX: VC and DT source for map 14 |

**MIPI TX42 (0x4AA)**

| BIT   | 7               | 6 | 5 | 4 | 3 | 2 | 1 | 0 |
|-------|-----------------|---|---|---|---|---|---|---|
| Field | MAP_DST_14[7:0] |   |   |   |   |   |   |   |
| Reset | 0x00            |   |   |   |   |   |   |   |

|                    |             |
|--------------------|-------------|
| <b>Access Type</b> | Write, Read |
|--------------------|-------------|

| <b>BITFIELD</b> | <b>BITS</b> | <b>DESCRIPTION</b>   | <b>DECODE</b>                          |
|-----------------|-------------|--|--|
| MAP_DST_14      | 7:0         | Mapping Destination Register 14<br>The register is split into two decode segments:<br>bits[7:6] VC - Virtual channel<br>bits[5:0] DT - Data type | 0xXX: VC and DT destination for map 14 |

**MIPI TX43 (0x4AB)**

| <b>BIT</b>         | <b>7</b>        | <b>6</b> | <b>5</b> | <b>4</b> | <b>3</b> | <b>2</b> | <b>1</b> | <b>0</b> |
|--------------------|-----------------|----------|----------|----------|----------|----------|----------|----------|
| <b>Field</b>       | MAP_SRC_15[7:0] |          |          |          |          |          |          |          |
| <b>Reset</b>       | 0x00            |          |          |          |          |          |          |          |
| <b>Access Type</b> | Write, Read     |          |          |          |          |          |          |          |

| <b>BITFIELD</b> | <b>BITS</b> | <b>DESCRIPTION</b>  | <b>DECODE</b>                     |
|-----------------|-------------|---|-----------------------------------|
| MAP_SRC_15      | 7:0         | Mapping Source Register 15<br>The register is split into two decode segments:<br>bits[7:6] VC - Virtual channel<br>bits[5:0] DT - Data type | 0xXX: VC and DT source for map 15 |

**MIPI TX44 (0x4AC)**

| <b>BIT</b>         | <b>7</b>        | <b>6</b> | <b>5</b> | <b>4</b> | <b>3</b> | <b>2</b> | <b>1</b> | <b>0</b> |
|--------------------|-----------------|----------|----------|----------|----------|----------|----------|----------|
| <b>Field</b>       | MAP_DST_15[7:0] |          |          |          |          |          |          |          |
| <b>Reset</b>       | 0x00            |          |          |          |          |          |          |          |
| <b>Access Type</b> | Write, Read     |          |          |          |          |          |          |          |

| <b>BITFIELD</b> | <b>BITS</b> | <b>DESCRIPTION</b>   | <b>DECODE</b>                          |
|-----------------|-------------|--|--|
| MAP_DST_15      | 7:0         | Mapping Destination Register 15<br>The register is split into two decode segments:<br>bits[7:6] VC - Virtual channel<br>bits[5:0] DT - Data type | 0xXX: VC and DT destination for map 15 |

**MIPI TX45 (0x4AD)**

| BIT                | 7                    | 6 | 5                    | 4 | 3                    | 2 | 1                    | 0 |
|--------------------|----------------------|---|----------------------|---|----------------------|---|----------------------|---|
| <b>Field</b>       | MAP_DPHY_DEST_3[1:0] |   | MAP_DPHY_DEST_2[1:0] |   | MAP_DPHY_DEST_1[1:0] |   | MAP_DPHY_DEST_0[1:0] |   |
| <b>Reset</b>       | 0b00                 |   | 0b00                 |   | 0b00                 |   | 0b00                 |   |
| <b>Access Type</b> | Write, Read          |   | Write, Read          |   | Write, Read          |   | Write, Read          |   |

| BITFIELD        | BITS | DESCRIPTION   | DECODE   |
|-----------------|------|---|--|
| MAP_DPHY_DEST_3 | 7:6  | CSI2 controller destination for MAP_SRC_3 (0x493) and MAP_DST_0 (0x48E) mapping bitfields | 0b00: Map to DPHY0 (4x2 mode only)<br>0b01: Map to DPHY1<br>0b10: Map to DPHY2<br>0b11: Map to DPHY3 (4x2 mode only) |
| MAP_DPHY_DEST_2 | 5:4  | CSI2 controller destination for MAP_SRC_2 (0x491) and MAP_DST_0 (0x48E) mapping bitfields | 0b00: Map to DPHY0 (4x2 mode only)<br>0b01: Map to DPHY1<br>0b10: Map to DPHY2<br>0b11: Map to DPHY3 (4x2 mode only) |
| MAP_DPHY_DEST_1 | 3:2  | CSI2 controller destination for MAP_SRC_1 (0x48F) and MAP_DST_0 (0x48E) mapping bitfields | 0b00: Map to DPHY0 (4x2 mode only)<br>0b01: Map to DPHY1<br>0b10: Map to DPHY2<br>0b11: Map to DPHY3 (4x2 mode only) |
| MAP_DPHY_DEST_0 | 1:0  | CSI2 controller destination for MAP_SRC_0 (0x48D) and MAP_DST_0 (0x48E) mapping bitfields | 0b00: Map to DPHY0 (4x2 mode only)<br>0b01: Map to DPHY1<br>0b10: Map to DPHY2<br>0b11: Map to DPHY3 (4x2 mode only) |

**MIPI TX46 (0x4AE)**

| BIT                | 7                    | 6 | 5                    | 4 | 3                    | 2 | 1                    | 0 |
|--------------------|----------------------|---|----------------------|---|----------------------|---|----------------------|---|
| <b>Field</b>       | MAP_DPHY_DEST_7[1:0] |   | MAP_DPHY_DEST_6[1:0] |   | MAP_DPHY_DEST_5[1:0] |   | MAP_DPHY_DEST_4[1:0] |   |
| <b>Reset</b>       | 0b00                 |   | 0b00                 |   | 0b00                 |   | 0b00                 |   |
| <b>Access Type</b> | Write, Read          |   | Write, Read          |   | Write, Read          |   | Write, Read          |   |

| BITFIELD        | BITS | DESCRIPTION   | DECODE   |
|-----------------|------|---|--|
| MAP_DPHY_DEST_7 | 7:6  | CSI2 controller destination for MAP_SRC_7 (0x49B) and MAP_DST_0 (0x48E) mapping bitfields | 0b00: Map to DPHY0 (4x2 mode only)<br>0b01: Map to DPHY1<br>0b10: Map to DPHY2<br>0b11: Map to DPHY3 (4x2 mode only) |
| MAP_DPHY_DEST_6 | 5:4  | CSI2 controller destination for MAP_SRC_6 (0x499) and MAP_DST_0 (0x48E) mapping bitfields | 0b00: Map to DPHY0 (4x2 mode only)<br>0b01: Map to DPHY1<br>0b10: Map to DPHY2<br>0b11: Map to DPHY3 (4x2 mode only) |
| MAP_DPHY_DEST_5 | 3:2  | CSI2 controller destination for MAP_SRC_5 (0x497) and MAP_DST_0 (0x48E) mapping bitfields | 0b00: Map to DPHY0 (4x2 mode only)<br>0b01: Map to DPHY1<br>0b10: Map to DPHY2<br>0b11: Map to DPHY3 (4x2 mode only) |

| BITFIELD        | BITS | DESCRIPTION   | DECODE   |
|-----------------|------|---|--|
| MAP_DPHY_DEST_4 | 1:0  | CSI2 controller destination for MAP_SRC_4 (0x495) and MAP_DST_0 (0x48E) mapping bitfields | 0b00: Map to DPHY0 (4x2 mode only)<br>0b01: Map to DPHY1<br>0b10: Map to DPHY2<br>0b11: Map to DPHY3 (4x2 mode only) |

**MIPI TX47 (0x4AF)**

| BIT         | 7                     | 6 | 5                     | 4 | 3                    | 2 | 1                    | 0 |
|-------------|-----------------------|---|-----------------------|---|----------------------|---|----------------------|---|
| Field       | MAP_DPHY_DEST_11[1:0] |   | MAP_DPHY_DEST_10[1:0] |   | MAP_DPHY_DEST_9[1:0] |   | MAP_DPHY_DEST_8[1:0] |   |
| Reset       | 0b00                  |   | 0b00                  |   | 0b00                 |   | 0b00                 |   |
| Access Type | Write, Read           |   | Write, Read           |   | Write, Read          |   | Write, Read          |   |

| BITFIELD         | BITS | DESCRIPTION  | DECODE   |
|------------------|------|--|--|
| MAP_DPHY_DEST_11 | 7:6  | CSI2 controller destination for MAP_SRC_11 (0x4A3) and MAP_DST_0 (0x48E) mapping bitfields | 0b00: Map to DPHY0 (4x2 mode only)<br>0b01: Map to DPHY1<br>0b10: Map to DPHY2<br>0b11: Map to DPHY3 (4x2 mode only) |
| MAP_DPHY_DEST_10 | 5:4  | CSI2 controller destination for MAP_SRC_10 (0x4A1) and MAP_DST_0 (0x48E) mapping bitfields | 0b00: Map to DPHY0 (4x2 mode only)<br>0b01: Map to DPHY1<br>0b10: Map to DPHY2<br>0b11: Map to DPHY3 (4x2 mode only) |
| MAP_DPHY_DEST_9  | 3:2  | CSI2 controller destination for MAP_SRC_9 (0x49F) and MAP_DST_0 (0x48E) mapping bitfields  | 0b00: Map to DPHY0 (4x2 mode only)<br>0b01: Map to DPHY1<br>0b10: Map to DPHY2<br>0b11: Map to DPHY3 (4x2 mode only) |
| MAP_DPHY_DEST_8  | 1:0  | CSI2 controller destination for MAP_SRC_8 (0x49D) and MAP_DST_0 (0x48E) mapping bitfields  | 0b00: Map to DPHY0 (4x2 mode only)<br>0b01: Map to DPHY1<br>0b10: Map to DPHY2<br>0b11: Map to DPHY3 (4x2 mode only) |

**MIPI TX48 (0x4B0)**

| BIT         | 7                     | 6 | 5                     | 4 | 3                     | 2 | 1                     | 0 |
|-------------|-----------------------|---|-----------------------|---|-----------------------|---|-----------------------|---|
| Field       | MAP_DPHY_DEST_15[1:0] |   | MAP_DPHY_DEST_14[1:0] |   | MAP_DPHY_DEST_13[1:0] |   | MAP_DPHY_DEST_12[1:0] |   |
| Reset       | 0b00                  |   | 0b00                  |   | 0b00                  |   | 0b00                  |   |
| Access Type | Write, Read           |   | Write, Read           |   | Write, Read           |   | Write, Read           |   |

| BITFIELD         | BITS | DESCRIPTION  | DECODE   |
|------------------|------|--|--|
| MAP_DPHY_DEST_15 | 7:6  | CSI2 controller destination for MAP_SRC_15 (0x4AB) and MAP_DST_0 (0x48E) mapping bitfields | 0b00: Map to DPHY0 (4x2 mode only)<br>0b01: Map to DPHY1<br>0b10: Map to DPHY2<br>0b11: Map to DPHY3 (4x2 mode only) |

| BITFIELD         | BITS | DESCRIPTION  | DECODE   |
|------------------|------|--|--|
| MAP_DPHY_DEST_14 | 5:4  | CSI2 controller destination for MAP_SRC_14 (0x4A9) and MAP_DST_0 (0x48E) mapping bitfields | 0b00: Map to DPHY0 (4x2 mode only)<br>0b01: Map to DPHY1<br>0b10: Map to DPHY2<br>0b11: Map to DPHY3 (4x2 mode only) |
| MAP_DPHY_DEST_13 | 3:2  | CSI2 controller destination for MAP_SRC_13 (0x4A8) and MAP_DST_0 (0x48E) mapping bitfields | 0b00: Map to DPHY0 (4x2 mode only)<br>0b01: Map to DPHY1<br>0b10: Map to DPHY2<br>0b11: Map to DPHY3 (4x2 mode only) |
| MAP_DPHY_DEST_12 | 1:0  | CSI2 controller destination for MAP_SRC_12 (0x4A6) and MAP_DST_0 (0x48E) mapping bitfields | 0b00: Map to DPHY0 (4x2 mode only)<br>0b01: Map to DPHY1<br>0b10: Map to DPHY2<br>0b11: Map to DPHY3 (4x2 mode only) |

**MIPI TX50 (0x4B2)**

| BIT         | 7                 | 6 | 5 | 4 | 3 | 2 | 1 | 0 |
|-------------|-------------------|---|---|---|---|---|---|---|
| Field       | SKEW_PER_SEL[7:0] |   |   |   |   |   |   |   |
| Reset       | 0x00              |   |   |   |   |   |   |   |
| Access Type | Write, Read       |   |   |   |   |   |   |   |

| BITFIELD     | BITS | DESCRIPTION  | DECODE   |
|--------------|------|--|--|
| SKEW_PER_SEL | 7:0  | <p>Periodic Deskew Select Register</p> <p>The register is split into three decode segments:<br/> bit[7] Select periodic deskew calibration for one or all virtual channels<br/> bits[6:5] Reserved<br/> bits[4:0] Virtual channel to generate periodic deskew calibration when only one channel is selected by bit 7</p> | 0b0XXXXXXX: Generate periodic calibration deskew calibration on all virtual channels<br>0b1XXX0000: Periodic deskew calibration generated by virtual channel 0<br>0b1XXX0001: Periodic deskew calibration generated by virtual channel 1<br>0b1XXX0010: Periodic deskew calibration generated by virtual channel 2<br>0b1XXX0011: Periodic deskew calibration generated by virtual channel 3<br>0b1XXX0100: Periodic deskew calibration generated by virtual channel 4<br>0b1XXX0101: Periodic deskew calibration generated by virtual channel 5<br>0b1XXX0110: Periodic deskew calibration generated by virtual channel 6<br>0b1XXX0111: Periodic deskew calibration generated by virtual channel 7<br>0b1XXX1000: Periodic deskew calibration generated by virtual channel 8<br>0b1XXX1001: Periodic deskew calibration generated by virtual channel 9<br>0b1XXX1010: Periodic deskew calibration generated by virtual channel 10<br>0b1XXX1011: Periodic deskew calibration generated by virtual channel 11<br>0b1XXX1100: Periodic deskew calibration generated by virtual channel 12<br>0b1XXX1101: Periodic deskew calibration generated by virtual channel 13<br>0b1XXX1110: Periodic deskew calibration generated by virtual channel 14<br>0b1XXX1111: Periodic deskew calibration generated by virtual channel 15 |

**MIPI TX51 (0x4B3)**

| BIT         | 7                      | 6 | 5 | 4             | 3           | 2             | 1            | 0             |
|-------------|------------------------|---|---|---------------|-------------|---------------|--------------|---------------|
| Field       | TUN_WAIT_VS_START[2:0] |   |   | ALT2_MEM_MAP8 | MODE_DT     | ALT_MEM_MAP10 | ALT_MEM_MAP8 | ALT_MEM_MAP12 |
| Reset       | 0b000                  |   |   | 0b0           | 0b0         | 0b0           | 0b0          | 0b0           |
| Access Type | Write, Read            |   |   | Write, Read   | Write, Read | Write, Read   | Write, Read  | Write, Read   |

| BITFIELD          | BITS | DESCRIPTION  | DECODE  |
|-------------------|------|--|---|
| TUN_WAIT_VS_START | 7:5  | Number of VS frames to wait before sending MIPI packet<br><br>Tunneling mode only.   | 0x0: No wait<br>Others: Number of frames to wait                        |
| ALT2_MEM_MAP8     | 4    | Alternative memory map enable for 8-bit DT. When set to 1, expects received video data to be packed into 24-bit in an alternative way by the serializer. | 0b0: Alternate memory map disabled<br>0b1: Alternate memory map enabled |
| MODE_DT           | 3    | MIPI Tx enable 24-bit packing of 8-bit MIPI UDP  | 0b0: Disabled<br>0b1: Enabled   |
| ALT_MEM_MAP10     | 2    | Alternative memory map enable for 10-bit DT (expect alternative bit packing by serializer)   | 0b0: Alternate memory map disabled<br>0b1: Alternate memory map enabled |
| ALT_MEM_MAP8      | 1    | Alternative memory map enable for 8-bit DT (expect alternative bit packing by serializer)  | 0b0: Alternate memory map disabled<br>0b1: Alternate memory map enabled |
| ALT_MEM_MAP12     | 0    | Alternative memory map enable for 12-bit DT (expect alternative bit packing by serializer)   | 0b0: Alternate memory map disabled<br>0b1: Alternate memory map enabled |

**MIPI TX52 (0x4B4)**

| BIT         | 7           | 6               | 5 | 4                     | 3 | 2              | 1           | 0           |
|-------------|-------------|-----------------|---|-----------------------|---|----------------|-------------|-------------|
| Field       | TUN_NO_CORR | DESKEW_TUN[1:0] |   | TUN_SER_LANE_NUM[1:0] |   | DESKEW_TUN_SRC | TUN_DEST    | TUN_EN      |
| Reset       | 0b0         | 0b00            |   | 0b01                  |   | 0b1            | 0b1         | 0b0         |
| Access Type | Write, Read | Write, Read     |   | Write, Read           |   | Write, Read    | Write, Read | Write, Read |

| BITFIELD    | BITS | DESCRIPTION   | DECODE  |
|-------------|------|---|---|
| TUN_NO_CORR | 7    | Do not enable header error correction in tunneling mode | 0b0: Tunneling error correction enabled<br>0b1: Tunneling error correction disabled   |
| DESKEW_TUN  | 6:5  | Deskew Mode for CSI2 Tunneling                          | 0b00: Periodic deskew using deserializer DESKEW_PER register<br>0b01: Periodic deskew follows what Serializer receives with small offset adjustment by DESKEW_TUN_OFFSET. |

| BITFIELD         | BITS | DESCRIPTION   | DECODE  |
|------------------|------|---|---|
|                  |      |   | 0b10: Periodic deskew occurrence follows Serializer but width determined by register DESKEW_PER<br>0b11: Reserved |
| TUN_SER_LANE_NUM | 4:3  | Number of lanes in the serializer. Applies to CSI2 tunneling mode only, and CPHY mode only.                                     | 0b00: One data lane<br>0b01: Two data lanes<br>0b10: Three data lanes<br>0b11: Four data lanes                    |
| DESKEW_TUN_SRC   | 2    | Tunneling Deskew Source Select  | 0b0: Pipe Y<br>0b1: Pipe Z  |
| TUN_DEST         | 1    | Tunneling Pipe Destination  | 0b0: MIPI PHY 1<br>0b1: MIPI PHY 2  |
| TUN_EN           | 0    | Tunneling Enabled<br><br>The CFG pin sets this value initially, and further register writes to this register changes the value. | 0b0: Tunneling disabled<br>0b1: Tunneling enabled   |

**MIPI TX53 (0x4B5)**

| BIT         | 7                      | 6 | 5 | 4 | 3 | 2 | 1 | 0 |
|-------------|------------------------|---|---|---|---|---|---|---|
| Field       | DESKEW_TUN_OFFSET[7:0] |   |   |   |   |   |   |   |
| Reset       | 0x00                   |   |   |   |   |   |   |   |
| Access Type | Write, Read            |   |   |   |   |   |   |   |

| BITFIELD          | BITS | DESCRIPTION                   |
|-------------------|------|-------------------------------|
| DESKEW_TUN_OFFSET | 7:0  | Tunneling Deskew Width Offset |

**MIPI TX54 (0x4B6)**

| BIT         | 7                       | 6 | 5 | 4 | 3 | 2 | 1 | 0 |
|-------------|-------------------------|---|---|---|---|---|---|---|
| Field       | TUN_PKT_START_ADDR[7:0] |   |   |   |   |   |   |   |
| Reset       | 0x00                    |   |   |   |   |   |   |   |
| Access Type | Write, Read             |   |   |   |   |   |   |   |

| BITFIELD           | BITS | DESCRIPTION  | DECODE   |
|--------------------|------|--|--|
| TUN_PKT_START_ADDR | 7:0  | Specifies the start address of the long packet in Tunneling mode.<br><br>When 0, the long packet is sent out when the whole line is filled in line memory. When not 0, the long packet begins when | 0xXX: Value x 32 bytes filled in memory is when long packet starts |

| BITFIELD | BITS | DESCRIPTION  | DECODE |
|----------|------|--|--------|
|          |      | TUN_PKT_START_ADDR x 32 bytes are filled in the line memory. |        |

**MIPI TX55 (0x4B7)**

| BIT         | 7 | 6 | 5 | 4 | 3 | 2 | 1 | 0                  |
|-------------|---|---|---|---|---|---|---|--------------------|
| Field       | – | – | – | – | – | – | – | TUN_NO_CORR_LENGTH |
| Reset       | – | – | – | – | – | – | – | 0b0                |
| Access Type | – | – | – | – | – | – | – | Write, Read        |

| BITFIELD           | BITS | DESCRIPTION  | DECODE  |
|--------------------|------|--|---|
| TUN_NO_CORR_LENGTH | 0    | Do not enable header error packet length correction in Tunneling mode. | 0b0: Tunneling error correction enabled<br>0b1: Tunneling error correction disabled |

**MIPI TX10 (0x4CA)**

| BIT         | 7                  | 6 | 5            | 4 | 3 | 2 | 1 | 0 |
|-------------|--------------------|---|--------------|---|---|---|---|---|
| Field       | CSI2_LANE_CNT[1:0] |   | CSI2_CPHY_EN | – | – | – | – | – |
| Reset       | 0b11               |   | 0b0          | – | – | – | – | – |
| Access Type | Write, Read        |   | Write, Read  | – | – | – | – | – |

| BITFIELD      | BITS | DESCRIPTION                   | DECODE   |
|---------------|------|-------------------------------|--|
| CSI2_LANE_CNT | 7:6  | Set number of MIPI data lanes | 0b00: One data lane for port<br>0b01: Two data lanes for port<br>0b10: Three data lanes for port<br>0b11: Four data lanes for port |
| CSI2_CPHY_EN  | 5    | Enable CPHY                   | 0b0: CPHY disabled<br>0b1: CPHY enabled  |

**MIPI TX\_EXT0 (0x510)**

| BIT         | 7                | 6 | 5 | 4                | 3 | 2 | 1 | 0 |
|-------------|------------------|---|---|------------------|---|---|---|---|
| Field       | MAP_SRC_0_H[2:0] |   |   | MAP_DST_0_H[2:0] |   |   | – | – |
| Reset       | 0b000            |   |   | 0b000            |   |   | – | – |
| Access Type | Write, Read      |   |   | Write, Read      |   |   | – | – |

| BITFIELD    | BITS | DESCRIPTION   | DECODE                   |
|-------------|------|---|--------------------------|
| MAP_SRC_0_H | 7:5  | Mapping register source VC high 3 bits for extended mode      | 0xX: VC source MSBs      |
| MAP_DST_0_H | 4:2  | Mapping register destination VC high 3 bits for extended mode | 0xX: VC destination MSBs |

**MIPI TX\_EXT1 (0x511)**

| BIT         | 7                | 6 | 5 | 4                | 3 | 2 | 1 | 0 |
|-------------|------------------|---|---|------------------|---|---|---|---|
| Field       | MAP_SRC_1_H[2:0] |   |   | MAP_DST_1_H[2:0] |   |   | – | – |
| Reset       | 0b000            |   |   | 0b000            |   |   | – | – |
| Access Type | Write, Read      |   |   | Write, Read      |   |   | – | – |

| BITFIELD    | BITS | DESCRIPTION   | DECODE                   |
|-------------|------|---|--------------------------|
| MAP_SRC_1_H | 7:5  | Mapping register source VC high 3 bits for extended mode      | 0xX: VC source MSBs      |
| MAP_DST_1_H | 4:2  | Mapping register destination VC high 3 bits for extended mode | 0xX: VC destination MSBs |

**MIPI TX\_EXT2 (0x512)**

| BIT         | 7                | 6 | 5 | 4                | 3 | 2 | 1 | 0 |
|-------------|------------------|---|---|------------------|---|---|---|---|
| Field       | MAP_SRC_2_H[2:0] |   |   | MAP_DST_2_H[2:0] |   |   | – | – |
| Reset       | 0b000            |   |   | 0b000            |   |   | – | – |
| Access Type | Write, Read      |   |   | Write, Read      |   |   | – | – |

| BITFIELD    | BITS | DESCRIPTION   | DECODE                   |
|-------------|------|---|--------------------------|
| MAP_SRC_2_H | 7:5  | Mapping register source VC high 3 bits for extended mode      | 0xX: VC source MSBs      |
| MAP_DST_2_H | 4:2  | Mapping register destination VC high 3 bits for extended mode | 0xX: VC destination MSBs |

**MIPI TX\_EXT3 (0x513)**

| BIT | 7 | 6 | 5 | 4 | 3 | 2 | 1 | 0 |
|-----|---|---|---|---|---|---|---|---|
|-----|---|---|---|---|---|---|---|---|

|                    |                  |                  |   |   |
|--------------------|------------------|------------------|---|---|
| <b>Field</b>       | MAP_SRC_3_H[2:0] | MAP_DST_3_H[2:0] | – | – |
| <b>Reset</b>       | 0b000            | 0b000            | – | – |
| <b>Access Type</b> | Write, Read      | Write, Read      | – | – |

| <b>BITFIELD</b> | <b>BITS</b> | <b>DESCRIPTION</b>  | <b>DECODE</b>            |
|-----------------|-------------|---|--------------------------|
| MAP_SRC_3_H     | 7:5         | Mapping register source VC high 3 bits for extended mode      | 0xX: VC source MSBs      |
| MAP_DST_3_H     | 4:2         | Mapping register destination VC high 3 bits for extended mode | 0xX: VC destination MSBs |

**MIPI TX EXT4 (0x514)**

|                    |                  |          |          |                  |          |          |          |          |
|--------------------|------------------|----------|----------|------------------|----------|----------|----------|----------|
| <b>BIT</b>         | <b>7</b>         | <b>6</b> | <b>5</b> | <b>4</b>         | <b>3</b> | <b>2</b> | <b>1</b> | <b>0</b> |
| <b>Field</b>       | MAP_SRC_4_H[2:0] |          |          | MAP_DST_4_H[2:0] |          |          | –        | –        |
| <b>Reset</b>       | 0b000            |          |          | 0b000            |          |          | –        | –        |
| <b>Access Type</b> | Write, Read      |          |          | Write, Read      |          |          | –        | –        |

| <b>BITFIELD</b> | <b>BITS</b> | <b>DESCRIPTION</b>  | <b>DECODE</b>            |
|-----------------|-------------|---|--------------------------|
| MAP_SRC_4_H     | 7:5         | Mapping register source VC high 3 bits for extended mode      | 0xX: VC source MSBs      |
| MAP_DST_4_H     | 4:2         | Mapping register destination VC high 3 bits for extended mode | 0xX: VC destination MSBs |

**MIPI TX EXT5 (0x515)**

|                    |                  |          |          |                  |          |          |          |          |
|--------------------|------------------|----------|----------|------------------|----------|----------|----------|----------|
| <b>BIT</b>         | <b>7</b>         | <b>6</b> | <b>5</b> | <b>4</b>         | <b>3</b> | <b>2</b> | <b>1</b> | <b>0</b> |
| <b>Field</b>       | MAP_SRC_5_H[2:0] |          |          | MAP_DST_5_H[2:0] |          |          | –        | –        |
| <b>Reset</b>       | 0b000            |          |          | 0b000            |          |          | –        | –        |
| <b>Access Type</b> | Write, Read      |          |          | Write, Read      |          |          | –        | –        |

| <b>BITFIELD</b> | <b>BITS</b> | <b>DESCRIPTION</b>  | <b>DECODE</b>            |
|-----------------|-------------|---|--------------------------|
| MAP_SRC_5_H     | 7:5         | Mapping register source VC high 3 bits for extended mode      | 0xX: VC source MSBs      |
| MAP_DST_5_H     | 4:2         | Mapping register destination VC high 3 bits for extended mode | 0xX: VC destination MSBs |

**MIPI TX\_EXT6 (0x516)**

| BIT         | 7                | 6 | 5 | 4                | 3 | 2 | 1 | 0 |
|-------------|------------------|---|---|------------------|---|---|---|---|
| Field       | MAP_SRC_6_H[2:0] |   |   | MAP_DST_6_H[2:0] |   |   | – | – |
| Reset       | 0b000            |   |   | 0b000            |   |   | – | – |
| Access Type | Write, Read      |   |   | Write, Read      |   |   | – | – |

| BITFIELD    | BITS | DESCRIPTION   | DECODE                   |
|-------------|------|---|--------------------------|
| MAP_SRC_6_H | 7:5  | Mapping register source VC high 3 bits for extended mode      | 0xX: VC source MSBs      |
| MAP_DST_6_H | 4:2  | Mapping register destination VC high 3 bits for extended mode | 0xX: VC destination MSBs |

**MIPI TX\_EXT7 (0x517)**

| BIT         | 7                | 6 | 5 | 4                | 3 | 2 | 1 | 0 |
|-------------|------------------|---|---|------------------|---|---|---|---|
| Field       | MAP_SRC_7_H[2:0] |   |   | MAP_DST_7_H[2:0] |   |   | – | – |
| Reset       | 0b000            |   |   | 0b000            |   |   | – | – |
| Access Type | Write, Read      |   |   | Write, Read      |   |   | – | – |

| BITFIELD    | BITS | DESCRIPTION   | DECODE                   |
|-------------|------|---|--------------------------|
| MAP_SRC_7_H | 7:5  | Mapping register source VC high 3 bits for extended mode      | 0xX: VC source MSBs      |
| MAP_DST_7_H | 4:2  | Mapping register destination VC high 3 bits for extended mode | 0xX: VC destination MSBs |

**MIPI TX\_EXT8 (0x518)**

| BIT         | 7                | 6 | 5 | 4                | 3 | 2 | 1 | 0 |
|-------------|------------------|---|---|------------------|---|---|---|---|
| Field       | MAP_SRC_8_H[2:0] |   |   | MAP_DST_8_H[2:0] |   |   | – | – |
| Reset       | 0b000            |   |   | 0b000            |   |   | – | – |
| Access Type | Write, Read      |   |   | Write, Read      |   |   | – | – |

| BITFIELD    | BITS | DESCRIPTION   | DECODE                   |
|-------------|------|---|--------------------------|
| MAP_SRC_8_H | 7:5  | Mapping register source VC high 3 bits for extended mode      | 0xX: VC source MSBs      |
| MAP_DST_8_H | 4:2  | Mapping register destination VC high 3 bits for extended mode | 0xX: VC destination MSBs |

**MIPI TX EXT9 (0x519)**

| BIT         | 7                | 6 | 5 | 4                | 3 | 2 | 1 | 0 |
|-------------|------------------|---|---|------------------|---|---|---|---|
| Field       | MAP_SRC_9_H[2:0] |   |   | MAP_DST_9_H[2:0] |   |   | – | – |
| Reset       | 0b000            |   |   | 0b000            |   |   | – | – |
| Access Type | Write, Read      |   |   | Write, Read      |   |   | – | – |

| BITFIELD    | BITS | DESCRIPTION   | DECODE                   |
|-------------|------|---|--------------------------|
| MAP_SRC_9_H | 7:5  | Mapping register source VC high 3 bits for extended mode      | 0xX: VC source MSBs      |
| MAP_DST_9_H | 4:2  | Mapping register destination VC high 3 bits for extended mode | 0xX: VC destination MSBs |

**MIPI TX EXT10 (0x51A)**

| BIT         | 7                 | 6 | 5 | 4                 | 3 | 2 | 1 | 0 |
|-------------|-------------------|---|---|-------------------|---|---|---|---|
| Field       | MAP_SRC_10_H[2:0] |   |   | MAP_DST_10_H[2:0] |   |   | – | – |
| Reset       | 0b000             |   |   | 0b000             |   |   | – | – |
| Access Type | Write, Read       |   |   | Write, Read       |   |   | – | – |

| BITFIELD     | BITS | DESCRIPTION   | DECODE                   |
|--------------|------|---|--------------------------|
| MAP_SRC_10_H | 7:5  | Mapping register source VC high 3 bits for extended mode      | 0xX: VC source MSBs      |
| MAP_DST_10_H | 4:2  | Mapping register destination VC high 3 bits for extended mode | 0xX: VC destination MSBs |

**MIPI TX EXT11 (0x51B)**

| BIT | 7 | 6 | 5 | 4 | 3 | 2 | 1 | 0 |
|-----|---|---|---|---|---|---|---|---|
|-----|---|---|---|---|---|---|---|---|

|                    |                   |                   |   |   |
|--------------------|-------------------|-------------------|---|---|
| <b>Field</b>       | MAP_SRC_11_H[2:0] | MAP_DST_11_H[2:0] | – | – |
| <b>Reset</b>       | 0b000             | 0b000             | – | – |
| <b>Access Type</b> | Write, Read       | Write, Read       | – | – |

| BITFIELD     | BITS | DESCRIPTION   | DECODE                   |
|--------------|------|---|--------------------------|
| MAP_SRC_11_H | 7:5  | Mapping register source VC high 3 bits for extended mode      | 0xX: VC source MSBs      |
| MAP_DST_11_H | 4:2  | Mapping register destination VC high 3 bits for extended mode | 0xX: VC destination MSBs |

**MIPI TX EXT12 (0x51C)**

|                    |                   |          |          |                   |          |          |          |          |
|--------------------|-------------------|----------|----------|-------------------|----------|----------|----------|----------|
| <b>BIT</b>         | <b>7</b>          | <b>6</b> | <b>5</b> | <b>4</b>          | <b>3</b> | <b>2</b> | <b>1</b> | <b>0</b> |
| <b>Field</b>       | MAP_SRC_12_H[2:0] |          |          | MAP_DST_12_H[2:0] |          |          | –        | –        |
| <b>Reset</b>       | 0b000             |          |          | 0b000             |          |          | –        | –        |
| <b>Access Type</b> | Write, Read       |          |          | Write, Read       |          |          | –        | –        |

| BITFIELD     | BITS | DESCRIPTION   | DECODE                   |
|--------------|------|---|--------------------------|
| MAP_SRC_12_H | 7:5  | Mapping register source VC high 3 bits for extended mode      | 0xX: VC source MSBs      |
| MAP_DST_12_H | 4:2  | Mapping register destination VC high 3 bits for extended mode | 0xX: VC destination MSBs |

**MIPI TX EXT13 (0x51D)**

|                    |                   |          |          |                   |          |          |          |          |
|--------------------|-------------------|----------|----------|-------------------|----------|----------|----------|----------|
| <b>BIT</b>         | <b>7</b>          | <b>6</b> | <b>5</b> | <b>4</b>          | <b>3</b> | <b>2</b> | <b>1</b> | <b>0</b> |
| <b>Field</b>       | MAP_SRC_13_H[2:0] |          |          | MAP_DST_13_H[2:0] |          |          | –        | –        |
| <b>Reset</b>       | 0b000             |          |          | 0b000             |          |          | –        | –        |
| <b>Access Type</b> | Write, Read       |          |          | Write, Read       |          |          | –        | –        |

| BITFIELD     | BITS | DESCRIPTION   | DECODE                   |
|--------------|------|---|--------------------------|
| MAP_SRC_13_H | 7:5  | Mapping register source VC high 3 bits for extended mode      | 0xX: VC source MSBs      |
| MAP_DST_13_H | 4:2  | Mapping register destination VC high 3 bits for extended mode | 0xX: VC destination MSBs |

**MIPI TX\_EXT14 (0x51E)**

| BIT         | 7                 | 6 | 5 | 4                 | 3 | 2 | 1 | 0 |
|-------------|-------------------|---|---|-------------------|---|---|---|---|
| Field       | MAP_SRC_14_H[2:0] |   |   | MAP_DST_14_H[2:0] |   |   | – | – |
| Reset       | 0b000             |   |   | 0b000             |   |   | – | – |
| Access Type | Write, Read       |   |   | Write, Read       |   |   | – | – |

| BITFIELD     | BITS | DESCRIPTION   | DECODE                   |
|--------------|------|---|--------------------------|
| MAP_SRC_14_H | 7:5  | Mapping register source VC high 3 bits for extended mode      | 0xX: VC source MSBs      |
| MAP_DST_14_H | 4:2  | Mapping register destination VC high 3 bits for extended mode | 0xX: VC destination MSBs |

**MIPI TX\_EXT15 (0x51F)**

| BIT         | 7                 | 6 | 5 | 4                 | 3 | 2 | 1 | 0 |
|-------------|-------------------|---|---|-------------------|---|---|---|---|
| Field       | MAP_SRC_15_H[2:0] |   |   | MAP_DST_15_H[2:0] |   |   | – | – |
| Reset       | 0b000             |   |   | 0b000             |   |   | – | – |
| Access Type | Write, Read       |   |   | Write, Read       |   |   | – | – |

| BITFIELD     | BITS | DESCRIPTION   | DECODE                   |
|--------------|------|---|--------------------------|
| MAP_SRC_15_H | 7:5  | Mapping register source VC high 3 bits for extended mode      | 0xX: VC source MSBs      |
| MAP_DST_15_H | 4:2  | Mapping register destination VC high 3 bits for extended mode | 0xX: VC destination MSBs |

**MIPI TX\_EXT0 (0x520)**

| BIT         | 7                | 6 | 5 | 4                | 3 | 2 | 1 | 0 |
|-------------|------------------|---|---|------------------|---|---|---|---|
| Field       | MAP_SRC_0_H[2:0] |   |   | MAP_DST_0_H[2:0] |   |   | – | – |
| Reset       | 0b000            |   |   | 0b000            |   |   | – | – |
| Access Type | Write, Read      |   |   | Write, Read      |   |   | – | – |

| BITFIELD    | BITS | DESCRIPTION   | DECODE                   |
|-------------|------|---|--------------------------|
| MAP_SRC_0_H | 7:5  | Mapping register source VC high 3 bits for extended mode      | 0xX: VC source MSBs      |
| MAP_DST_0_H | 4:2  | Mapping register destination VC high 3 bits for extended mode | 0xX: VC destination MSBs |

**MIPI TX EXT1 (0x521)**

| BIT         | 7                | 6 | 5 | 4                | 3 | 2 | 1 | 0 |
|-------------|------------------|---|---|------------------|---|---|---|---|
| Field       | MAP_SRC_1_H[2:0] |   |   | MAP_DST_1_H[2:0] |   |   | – | – |
| Reset       | 0b000            |   |   | 0b000            |   |   | – | – |
| Access Type | Write, Read      |   |   | Write, Read      |   |   | – | – |

| BITFIELD    | BITS | DESCRIPTION   | DECODE                   |
|-------------|------|---|--------------------------|
| MAP_SRC_1_H | 7:5  | Mapping register source VC high 3 bits for extended mode      | 0xX: VC source MSBs      |
| MAP_DST_1_H | 4:2  | Mapping register destination VC high 3 bits for extended mode | 0xX: VC destination MSBs |

**MIPI TX EXT2 (0x522)**

| BIT         | 7                | 6 | 5 | 4                | 3 | 2 | 1 | 0 |
|-------------|------------------|---|---|------------------|---|---|---|---|
| Field       | MAP_SRC_2_H[2:0] |   |   | MAP_DST_2_H[2:0] |   |   | – | – |
| Reset       | 0b000            |   |   | 0b000            |   |   | – | – |
| Access Type | Write, Read      |   |   | Write, Read      |   |   | – | – |

| BITFIELD    | BITS | DESCRIPTION   | DECODE                   |
|-------------|------|---|--------------------------|
| MAP_SRC_2_H | 7:5  | Mapping register source VC high 3 bits for extended mode      | 0xX: VC source MSBs      |
| MAP_DST_2_H | 4:2  | Mapping register destination VC high 3 bits for extended mode | 0xX: VC destination MSBs |

**MIPI TX EXT3 (0x523)**

| BIT | 7 | 6 | 5 | 4 | 3 | 2 | 1 | 0 |
|-----|---|---|---|---|---|---|---|---|
|-----|---|---|---|---|---|---|---|---|

|                    |                  |                  |   |   |
|--------------------|------------------|------------------|---|---|
| <b>Field</b>       | MAP_SRC_3_H[2:0] | MAP_DST_3_H[2:0] | – | – |
| <b>Reset</b>       | 0b000            | 0b000            | – | – |
| <b>Access Type</b> | Write, Read      | Write, Read      | – | – |

| <b>BITFIELD</b> | <b>BITS</b> | <b>DESCRIPTION</b>  | <b>DECODE</b>            |
|-----------------|-------------|---|--------------------------|
| MAP_SRC_3_H     | 7:5         | Mapping register source VC high 3 bits for extended mode      | 0xX: VC source MSBs      |
| MAP_DST_3_H     | 4:2         | Mapping register destination VC high 3 bits for extended mode | 0xX: VC destination MSBs |

**MIPI TX EXT4 (0x524)**

|                    |                  |          |          |                  |          |          |          |          |
|--------------------|------------------|----------|----------|------------------|----------|----------|----------|----------|
| <b>BIT</b>         | <b>7</b>         | <b>6</b> | <b>5</b> | <b>4</b>         | <b>3</b> | <b>2</b> | <b>1</b> | <b>0</b> |
| <b>Field</b>       | MAP_SRC_4_H[2:0] |          |          | MAP_DST_4_H[2:0] |          |          | –        | –        |
| <b>Reset</b>       | 0b000            |          |          | 0b000            |          |          | –        | –        |
| <b>Access Type</b> | Write, Read      |          |          | Write, Read      |          |          | –        | –        |

| <b>BITFIELD</b> | <b>BITS</b> | <b>DESCRIPTION</b>  | <b>DECODE</b>            |
|-----------------|-------------|---|--------------------------|
| MAP_SRC_4_H     | 7:5         | Mapping register source VC high 3 bits for extended mode      | 0xX: VC source MSBs      |
| MAP_DST_4_H     | 4:2         | Mapping register destination VC high 3 bits for extended mode | 0xX: VC destination MSBs |

**MIPI TX EXT5 (0x525)**

|                    |                  |          |          |                  |          |          |          |          |
|--------------------|------------------|----------|----------|------------------|----------|----------|----------|----------|
| <b>BIT</b>         | <b>7</b>         | <b>6</b> | <b>5</b> | <b>4</b>         | <b>3</b> | <b>2</b> | <b>1</b> | <b>0</b> |
| <b>Field</b>       | MAP_SRC_5_H[2:0] |          |          | MAP_DST_5_H[2:0] |          |          | –        | –        |
| <b>Reset</b>       | 0b000            |          |          | 0b000            |          |          | –        | –        |
| <b>Access Type</b> | Write, Read      |          |          | Write, Read      |          |          | –        | –        |

| <b>BITFIELD</b> | <b>BITS</b> | <b>DESCRIPTION</b>  | <b>DECODE</b>            |
|-----------------|-------------|---|--------------------------|
| MAP_SRC_5_H     | 7:5         | Mapping register source VC high 3 bits for extended mode      | 0xX: VC source MSBs      |
| MAP_DST_5_H     | 4:2         | Mapping register destination VC high 3 bits for extended mode | 0xX: VC destination MSBs |

**MIPI TX\_EXT6 (0x526)**

| BIT         | 7                | 6 | 5 | 4                | 3 | 2 | 1 | 0 |
|-------------|------------------|---|---|------------------|---|---|---|---|
| Field       | MAP_SRC_6_H[2:0] |   |   | MAP_DST_6_H[2:0] |   |   | – | – |
| Reset       | 0b000            |   |   | 0b000            |   |   | – | – |
| Access Type | Write, Read      |   |   | Write, Read      |   |   | – | – |

| BITFIELD    | BITS | DESCRIPTION   | DECODE                   |
|-------------|------|---|--------------------------|
| MAP_SRC_6_H | 7:5  | Mapping register source VC high 3 bits for extended mode      | 0xX: VC source MSBs      |
| MAP_DST_6_H | 4:2  | Mapping register destination VC high 3 bits for extended mode | 0xX: VC destination MSBs |

**MIPI TX\_EXT7 (0x527)**

| BIT         | 7                | 6 | 5 | 4                | 3 | 2 | 1 | 0 |
|-------------|------------------|---|---|------------------|---|---|---|---|
| Field       | MAP_SRC_7_H[2:0] |   |   | MAP_DST_7_H[2:0] |   |   | – | – |
| Reset       | 0b000            |   |   | 0b000            |   |   | – | – |
| Access Type | Write, Read      |   |   | Write, Read      |   |   | – | – |

| BITFIELD    | BITS | DESCRIPTION   | DECODE                   |
|-------------|------|---|--------------------------|
| MAP_SRC_7_H | 7:5  | Mapping register source VC high 3 bits for extended mode      | 0xX: VC source MSBs      |
| MAP_DST_7_H | 4:2  | Mapping register destination VC high 3 bits for extended mode | 0xX: VC destination MSBs |

**MIPI TX\_EXT8 (0x528)**

| BIT         | 7                | 6 | 5 | 4                | 3 | 2 | 1 | 0 |
|-------------|------------------|---|---|------------------|---|---|---|---|
| Field       | MAP_SRC_8_H[2:0] |   |   | MAP_DST_8_H[2:0] |   |   | – | – |
| Reset       | 0b000            |   |   | 0b000            |   |   | – | – |
| Access Type | Write, Read      |   |   | Write, Read      |   |   | – | – |

| BITFIELD    | BITS | DESCRIPTION   | DECODE                   |
|-------------|------|---|--------------------------|
| MAP_SRC_8_H | 7:5  | Mapping register source VC high 3 bits for extended mode      | 0xX: VC source MSBs      |
| MAP_DST_8_H | 4:2  | Mapping register destination VC high 3 bits for extended mode | 0xX: VC destination MSBs |

**MIPI TX EXT9 (0x529)**

| BIT         | 7                | 6 | 5 | 4                | 3 | 2 | 1 | 0 |
|-------------|------------------|---|---|------------------|---|---|---|---|
| Field       | MAP_SRC_9_H[2:0] |   |   | MAP_DST_9_H[2:0] |   |   | – | – |
| Reset       | 0b000            |   |   | 0b000            |   |   | – | – |
| Access Type | Write, Read      |   |   | Write, Read      |   |   | – | – |

| BITFIELD    | BITS | DESCRIPTION   | DECODE                   |
|-------------|------|---|--------------------------|
| MAP_SRC_9_H | 7:5  | Mapping register source VC high 3 bits for extended mode      | 0xX: VC source MSBs      |
| MAP_DST_9_H | 4:2  | Mapping register destination VC high 3 bits for extended mode | 0xX: VC destination MSBs |

**MIPI TX EXT10 (0x52A)**

| BIT         | 7                 | 6 | 5 | 4                 | 3 | 2 | 1 | 0 |
|-------------|-------------------|---|---|-------------------|---|---|---|---|
| Field       | MAP_SRC_10_H[2:0] |   |   | MAP_DST_10_H[2:0] |   |   | – | – |
| Reset       | 0b000             |   |   | 0b000             |   |   | – | – |
| Access Type | Write, Read       |   |   | Write, Read       |   |   | – | – |

| BITFIELD     | BITS | DESCRIPTION   | DECODE                   |
|--------------|------|---|--------------------------|
| MAP_SRC_10_H | 7:5  | Mapping register source VC high 3 bits for extended mode      | 0xX: VC source MSBs      |
| MAP_DST_10_H | 4:2  | Mapping register destination VC high 3 bits for extended mode | 0xX: VC destination MSBs |

**MIPI TX EXT11 (0x52B)**

| BIT | 7 | 6 | 5 | 4 | 3 | 2 | 1 | 0 |
|-----|---|---|---|---|---|---|---|---|
|-----|---|---|---|---|---|---|---|---|

|                    |                   |                   |   |   |
|--------------------|-------------------|-------------------|---|---|
| <b>Field</b>       | MAP_SRC_11_H[2:0] | MAP_DST_11_H[2:0] | – | – |
| <b>Reset</b>       | 0b000             | 0b000             | – | – |
| <b>Access Type</b> | Write, Read       | Write, Read       | – | – |

| BITFIELD     | BITS | DESCRIPTION   | DECODE                   |
|--------------|------|---|--------------------------|
| MAP_SRC_11_H | 7:5  | Mapping register source VC high 3 bits for extended mode      | 0xX: VC source MSBs      |
| MAP_DST_11_H | 4:2  | Mapping register destination VC high 3 bits for extended mode | 0xX: VC destination MSBs |

### MIPI TX EXT12 (0x52C)

| BIT                | 7                 | 6 | 5 | 4                 | 3 | 2 | 1 | 0 |
|--------------------|-------------------|---|---|-------------------|---|---|---|---|
| <b>Field</b>       | MAP_SRC_12_H[2:0] |   |   | MAP_DST_12_H[2:0] |   |   | – | – |
| <b>Reset</b>       | 0b000             |   |   | 0b000             |   |   | – | – |
| <b>Access Type</b> | Write, Read       |   |   | Write, Read       |   |   | – | – |

| BITFIELD     | BITS | DESCRIPTION   | DECODE                   |
|--------------|------|---|--------------------------|
| MAP_SRC_12_H | 7:5  | Mapping register source VC high 3 bits for extended mode      | 0xX: VC source MSBs      |
| MAP_DST_12_H | 4:2  | Mapping register destination VC high 3 bits for extended mode | 0xX: VC destination MSBs |

### MIPI TX EXT13 (0x52D)

| BIT                | 7                 | 6 | 5 | 4                 | 3 | 2 | 1 | 0 |
|--------------------|-------------------|---|---|-------------------|---|---|---|---|
| <b>Field</b>       | MAP_SRC_13_H[2:0] |   |   | MAP_DST_13_H[2:0] |   |   | – | – |
| <b>Reset</b>       | 0b000             |   |   | 0b000             |   |   | – | – |
| <b>Access Type</b> | Write, Read       |   |   | Write, Read       |   |   | – | – |

| BITFIELD     | BITS | DESCRIPTION   | DECODE                   |
|--------------|------|---|--------------------------|
| MAP_SRC_13_H | 7:5  | Mapping register source VC high 3 bits for extended mode      | 0xX: VC source MSBs      |
| MAP_DST_13_H | 4:2  | Mapping register destination VC high 3 bits for extended mode | 0xX: VC destination MSBs |

**MIPI TX\_EXT14 (0x52E)**

| BIT         | 7                 | 6 | 5 | 4                 | 3 | 2 | 1 | 0 |
|-------------|-------------------|---|---|-------------------|---|---|---|---|
| Field       | MAP_SRC_14_H[2:0] |   |   | MAP_DST_14_H[2:0] |   |   | – | – |
| Reset       | 0b000             |   |   | 0b000             |   |   | – | – |
| Access Type | Write, Read       |   |   | Write, Read       |   |   | – | – |

| BITFIELD     | BITS | DESCRIPTION   | DECODE                   |
|--------------|------|---|--------------------------|
| MAP_SRC_14_H | 7:5  | Mapping register source VC high 3 bits for extended mode      | 0xX: VC source MSBs      |
| MAP_DST_14_H | 4:2  | Mapping register destination VC high 3 bits for extended mode | 0xX: VC destination MSBs |

**MIPI TX\_EXT15 (0x52F)**

| BIT         | 7                 | 6 | 5 | 4                 | 3 | 2 | 1 | 0 |
|-------------|-------------------|---|---|-------------------|---|---|---|---|
| Field       | MAP_SRC_15_H[2:0] |   |   | MAP_DST_15_H[2:0] |   |   | – | – |
| Reset       | 0b000             |   |   | 0b000             |   |   | – | – |
| Access Type | Write, Read       |   |   | Write, Read       |   |   | – | – |

| BITFIELD     | BITS | DESCRIPTION   | DECODE                   |
|--------------|------|---|--------------------------|
| MAP_SRC_15_H | 7:5  | Mapping register source VC high 3 bits for extended mode      | 0xX: VC source MSBs      |
| MAP_DST_15_H | 4:2  | Mapping register destination VC high 3 bits for extended mode | 0xX: VC destination MSBs |

**CFG\_0 (0x540)**

| BIT         | 7            | 6 | 5 | 4 | 3 | 2 | 1 | 0 |
|-------------|--------------|---|---|---|---|---|---|---|
| Field       | VS_OUT1[2:0] |   |   | – | – | – | – | – |
| Reset       | 0b000        |   |   | – | – | – | – | – |
| Access Type | Write, Read  |   |   | – | – | – | – | – |

| BITFIELD | BITS | DESCRIPTION  | DECODE   |
|----------|------|--|--|
| VS_OUT1  | 7:5  | Output VSYNC from VS1 pin (Only valid in Pixel Mode)<br><br>MSB is enabled.<br>LSB 2 bits select which video pipeline to output. | 0x0: Reserved<br>0x1: From Video Pipeline Y<br>0x2: From Video Pipeline Z<br>0x3: Reserved |

**CFG 1 (0x541)**

| BIT         | 7            | 6 | 5 | 4 | 3 | 2 | 1 | 0 |
|-------------|--------------|---|---|---|---|---|---|---|
| Field       | VS_OUT2[2:0] |   |   | - | - | - | - | - |
| Reset       | 0b000        |   |   | - | - | - | - | - |
| Access Type | Write, Read  |   |   | - | - | - | - | - |

| BITFIELD | BITS | DESCRIPTION  | DECODE   |
|----------|------|--|--|
| VS_OUT2  | 7:5  | Output VSYNC from VS2 pin (Only valid in Pixel Mode)<br><br>MSB is enabled.<br>LSB 2 bits select which video pipeline to output. | 0x0: Reserved<br>0x1: From Video Pipeline Y<br>0x2: From Video Pipeline Z<br>0x3: Reserved |

**CFG 2 (0x542)**

| BIT         | 7            | 6 | 5 | 4 | 3 | 2 | 1 | 0 |
|-------------|--------------|---|---|---|---|---|---|---|
| Field       | HS_OUT1[2:0] |   |   | - | - | - | - | - |
| Reset       | 0b000        |   |   | - | - | - | - | - |
| Access Type | Write, Read  |   |   | - | - | - | - | - |

| BITFIELD | BITS | DESCRIPTION  | DECODE   |
|----------|------|--|--|
| HS_OUT1  | 7:5  | Output DE/DV from HS1 pin (Only valid in Pixel Mode)<br><br>MSB is enabled.<br>LSB 2 bits select which video pipeline to output. | 0x0: Reserved<br>0x1: From Video Pipeline Y<br>0x2: From Video Pipeline Z<br>0x3: Reserved |

**UART\_PT 0 (0x548)**

| BIT | 7 | 6 | 5 | 4 | 3 | 2 | 1 | 0 |
|-----|---|---|---|---|---|---|---|---|
|-----|---|---|---|---|---|---|---|---|

|                    |                    |
|--------------------|--------------------|
| <b>Field</b>       | BITLEN_PT_1_L[7:0] |
| <b>Reset</b>       | 0x96               |
| <b>Access Type</b> | Write, Read        |

| BITFIELD      | BITS | DESCRIPTION  | DECODE   |
|---------------|------|--|--|
| BITLEN_PT_1_L | 7:0  | <p>Custom UART bit length for pass-through UART Channel 1</p> <p>Set BITLEN_MAN_CFG_1 (0x4F) to 1 to use this value.</p> <p>Set this register to the UART bit length divided by 6.666ns (LSB 8 bits)</p> | 0xXX: Low byte of custom UART bit length for pass-through UART Channel 1 |

#### UART PT 1 (0x549)

| BIT                | 7 | 6 | 5                  | 4 | 3 | 2 | 1 | 0 |
|--------------------|---|---|--------------------|---|---|---|---|---|
| <b>Field</b>       | – | – | BITLEN_PT_1_H[5:0] |   |   |   |   |   |
| <b>Reset</b>       | – | – | 0b000000           |   |   |   |   |   |
| <b>Access Type</b> | – | – | Write, Read        |   |   |   |   |   |

| BITFIELD      | BITS | DESCRIPTION   | DECODE  |
|---------------|------|---|---|
| BITLEN_PT_1_H | 5:0  | <p>High byte of custom UART bit length for pass-through UART Channel 1.</p> <p>Set BITLEN_MAN_CFG_1 (0x4F) to 1 to use this value.</p> <p>Set this register to the UART bit length divided by 6.666ns (LSB 8 bits).</p> | 0xXX: High byte of custom UART bit length for pass-through UART Channel 1 |

#### UART PT 2 (0x54A)

| BIT                | 7                  | 6 | 5 | 4 | 3 | 2 | 1 | 0 |
|--------------------|--------------------|---|---|---|---|---|---|---|
| <b>Field</b>       | BITLEN_PT_2_L[7:0] |   |   |   |   |   |   |   |
| <b>Reset</b>       | 0x96               |   |   |   |   |   |   |   |
| <b>Access Type</b> | Write, Read        |   |   |   |   |   |   |   |

| BITFIELD      | BITS | DESCRIPTION  | DECODE   |
|---------------|------|--|--|
| BITLEN_PT_2_L | 7:0  | <p>Low byte of custom UART bit length for pass-through UART Channel 2.</p> <p>Set BITLEN_MAN_CFG_2 (0x4F) to 1 to use this value.</p> <p>Set this register to the UART bit length divided by 6.666ns (LSB 8 bits).</p> | 0xXX: Low byte of custom UART bit length for pass-through UART Channel 2 |

**UART\_PT\_3 (0x54B)**

| BIT         | 7 | 6 | 5                  | 4 | 3 | 2 | 1 | 0 |
|-------------|---|---|--------------------|---|---|---|---|---|
| Field       | – | – | BITLEN_PT_2_H[5:0] |   |   |   |   |   |
| Reset       | – | – | 0b000000           |   |   |   |   |   |
| Access Type | – | – | Write, Read        |   |   |   |   |   |

| BITFIELD      | BITS | DESCRIPTION   | DECODE  |
|---------------|------|---|---|
| BITLEN_PT_2_H | 5:0  | <p>High byte of custom UART bit length for pass-through UART Channel 2.</p> <p>Set BITLEN_MAN_CFG_1 (0x4F) to 2 to use this value.</p> <p>Set this register to the UART bit length divided by 6.666ns (LSB 8 bits).</p> | 0xXX: High byte of custom UART bit length for pass-through UART Channel 2 |

**I2C\_PT\_4 (0x550)**

| BIT         | 7            | 6 | 5 | 4 | 3 | 2 | 1 | 0 |
|-------------|--------------|---|---|---|---|---|---|---|
| Field       | SRC_A_1[6:0] |   |   |   |   |   |   | – |
| Reset       | 0b0000000    |   |   |   |   |   |   | – |
| Access Type | Write, Read  |   |   |   |   |   |   | – |

| BITFIELD | BITS | DESCRIPTION   |
|----------|------|---|
| SRC_A_1  | 7:1  | <p>I<sup>2</sup>C address translator source A for pass-through 1 port</p> <p>When an I<sup>2</sup>C transaction across the GMSL link has a device address matching I<sup>2</sup>C SRC_A_1, the device address as seen on the remote side is replaced by the device address in I<sup>2</sup>C DST_A_1.</p> |

**I2C PT 5 (0x551)**

| BIT         | 7            | 6 | 5 | 4 | 3 | 2 | 1 | 0 |
|-------------|--------------|---|---|---|---|---|---|---|
| Field       | DST_A_1[6:0] |   |   |   |   |   |   | – |
| Reset       | 0b0000000    |   |   |   |   |   |   | – |
| Access Type | Write, Read  |   |   |   |   |   |   | – |

| BITFIELD | BITS | DESCRIPTION  |
|----------|------|--|
| DST_A_1  | 7:1  | I <sup>2</sup> C address translator destination A for pass-through 1 port<br>See the description of SRC_A_1. |

**I2C PT 6 (0x552)**

| BIT         | 7            | 6 | 5 | 4 | 3 | 2 | 1 | 0 |
|-------------|--------------|---|---|---|---|---|---|---|
| Field       | SRC_B_1[6:0] |   |   |   |   |   |   | – |
| Reset       | 0b0000000    |   |   |   |   |   |   | – |
| Access Type | Write, Read  |   |   |   |   |   |   | – |

| BITFIELD | BITS | DESCRIPTION  |
|----------|------|--|
| SRC_B_1  | 7:1  | I <sup>2</sup> C address translator source B for pass-through 1 port<br>When an I <sup>2</sup> C transaction across the GMSL link has a device address matching I <sup>2</sup> C SRC_B_1, the device address as seen on the remote side is replaced by the device address in I <sup>2</sup> C DST_B_1. |

**I2C PT 7 (0x553)**

| BIT         | 7            | 6 | 5 | 4 | 3 | 2 | 1 | 0 |
|-------------|--------------|---|---|---|---|---|---|---|
| Field       | DST_B_1[6:0] |   |   |   |   |   |   | – |
| Reset       | 0b0000000    |   |   |   |   |   |   | – |
| Access Type | Write, Read  |   |   |   |   |   |   | – |

| BITFIELD | BITS | DESCRIPTION  |
|----------|------|--|
| DST_B_1  | 7:1  | I <sup>2</sup> C address translator destination B for pass-through port 1<br>See the description of SRC_B_1. |

**I<sup>2</sup>C PT 8 (0x554)**

| BIT         | 7            | 6 | 5 | 4 | 3 | 2 | 1 | 0 |
|-------------|--------------|---|---|---|---|---|---|---|
| Field       | SRC_A_2[6:0] |   |   |   |   |   |   | – |
| Reset       | 0b0000000    |   |   |   |   |   |   | – |
| Access Type | Write, Read  |   |   |   |   |   |   | – |

| BITFIELD | BITS | DESCRIPTION  |
|----------|------|--|
| SRC_A_2  | 7:1  | I <sup>2</sup> C address translator source A for pass-through 2 port<br>When an I <sup>2</sup> C transaction across the GMSL link has a device address matching I <sup>2</sup> C SRC_A_2, the device address as seen on the remote side is replaced by the device address in I <sup>2</sup> C DST_A_2. |

**I<sup>2</sup>C PT 9 (0x555)**

| BIT         | 7            | 6 | 5 | 4 | 3 | 2 | 1 | 0 |
|-------------|--------------|---|---|---|---|---|---|---|
| Field       | DST_A_2[6:0] |   |   |   |   |   |   | – |
| Reset       | 0b0000000    |   |   |   |   |   |   | – |
| Access Type | Write, Read  |   |   |   |   |   |   | – |

| BITFIELD | BITS | DESCRIPTION  |
|----------|------|--|
| DST_A_2  | 7:1  | I <sup>2</sup> C address translator destination A for pass-through 2 port<br>See the description of SRC_A_2. |

**I<sup>2</sup>C PT 10 (0x556)**

| BIT   | 7            | 6 | 5 | 4 | 3 | 2 | 1 | 0 |
|-------|--------------|---|---|---|---|---|---|---|
| Field | SRC_B_2[6:0] |   |   |   |   |   |   | – |
| Reset | 0b0000000    |   |   |   |   |   |   | – |

|                    |             |   |
|--------------------|-------------|---|
| <b>Access Type</b> | Write, Read | – |
|--------------------|-------------|---|

| BITFIELD | BITS | DESCRIPTION  |
|----------|------|--|
| SRC_B_2  | 7:1  | I <sup>2</sup> C address translator source B for pass-through 2 port<br><br>When an I <sup>2</sup> C transaction across the GMSL link has a device address matching I <sup>2</sup> C SRC_B_2, the device address as seen on the remote side is replaced by the device address in I <sup>2</sup> C DST_B_2. |

**I<sup>2</sup>C PT 11 (0x557)**

| BIT                | 7            | 6 | 5 | 4 | 3 | 2 | 1 | 0 |
|--------------------|--------------|---|---|---|---|---|---|---|
| <b>Field</b>       | DST_B_2[6:0] |   |   |   |   |   |   | – |
| <b>Reset</b>       | 0b0000000    |   |   |   |   |   |   | – |
| <b>Access Type</b> | Write, Read  |   |   |   |   |   |   | – |

| BITFIELD | BITS | DESCRIPTION  |
|----------|------|--|
| DST_B_2  | 7:1  | I <sup>2</sup> C address translator destination B for pass-through 2 port<br><br>See the description of SRC_B_2. |

**CNT4 (0x55C)**

| BIT                | 7                     | 6 | 5 | 4 | 3 | 2 | 1 | 0 |
|--------------------|-----------------------|---|---|---|---|---|---|---|
| <b>Field</b>       | VID_PXL_CRC_ERR0[7:0] |   |   |   |   |   |   |   |
| <b>Reset</b>       | 0x00                  |   |   |   |   |   |   |   |
| <b>Access Type</b> | Read Clears All       |   |   |   |   |   |   |   |

| BITFIELD         | BITS | DESCRIPTION  |
|------------------|------|--|
| VID_PXL_CRC_ERR0 | 7:0  | Total number of video pixel CRC errors detected at video streams. Reset after reading or with the rising edge of LOCK. |

**CNT5 (0x55D)**

| BIT          | 7                     | 6 | 5 | 4 | 3 | 2 | 1 | 0 |
|--------------|-----------------------|---|---|---|---|---|---|---|
| <b>Field</b> | VID_PXL_CRC_ERR1[7:0] |   |   |   |   |   |   |   |

|                    |                 |
|--------------------|-----------------|
| <b>Reset</b>       | 0x00            |
| <b>Access Type</b> | Read Clears All |

| BITFIELD         | BITS | DESCRIPTION  |
|------------------|------|--|
| VID_PXL_CRC_ERR1 | 7:0  | Total number of video pixel CRC errors detected at video streams. Reset after reading or with the rising edge of LOCK. |

**CNT6 (0x55E)**

| BIT                | 7                     | 6 | 5 | 4 | 3 | 2 | 1 | 0 |
|--------------------|-----------------------|---|---|---|---|---|---|---|
| <b>Field</b>       | VID_PXL_CRC_ERR2[7:0] |   |   |   |   |   |   |   |
| <b>Reset</b>       | 0x00                  |   |   |   |   |   |   |   |
| <b>Access Type</b> | Read Clears All       |   |   |   |   |   |   |   |

| BITFIELD         | BITS | DESCRIPTION  |
|------------------|------|--|
| VID_PXL_CRC_ERR2 | 7:0  | Total number of video pixel CRC errors detected at video streams. Reset after reading or with the rising edge of LOCK. |

**CNT7 (0x55F)**

| BIT                | 7                     | 6 | 5 | 4 | 3 | 2 | 1 | 0 |
|--------------------|-----------------------|---|---|---|---|---|---|---|
| <b>Field</b>       | VID_PXL_CRC_ERR3[7:0] |   |   |   |   |   |   |   |
| <b>Reset</b>       | 0x00                  |   |   |   |   |   |   |   |
| <b>Access Type</b> | Read Clears All       |   |   |   |   |   |   |   |

| BITFIELD         | BITS | DESCRIPTION  |
|------------------|------|--|
| VID_PXL_CRC_ERR3 | 7:0  | Total number of video pixel CRC errors detected at video streams. Reset after reading or with the rising edge of LOCK. |

**PM\_OV\_STAT (0x560)**

| BIT          | 7 | 6 | 5                   | 4 | 3 | 2 | 1             | 0 |
|--------------|---|---|---------------------|---|---|---|---------------|---|
| <b>Field</b> | – | – | VDD18_OV_LEVEL[1:0] |   | – | – | OV_LEVEL[1:0] |   |
| <b>Reset</b> | – | – | 0b01                |   | – | – | 0b01          |   |

|             |   |   |             |   |   |             |
|-------------|---|---|-------------|---|---|-------------|
| Access Type | – | – | Write, Read | – | – | Write, Read |
|-------------|---|---|-------------|---|---|-------------|

| BITFIELD       | BITS | DESCRIPTION   | DECODE   |
|----------------|------|---|--|
| VDD18_OV_LEVEL | 5:4  | V <sub>DD18</sub> overvoltage comparator trip level                     | 0x0: 1.98V<br>0x1: 2.02V<br>0x2: Reserved (2.07V)<br>0x3: Reserved (2.12V) |
| OV_LEVEL       | 1:0  | V <sub>DD</sub> (V <sub>DD_sw</sub> ) overvoltage comparator trip level | 0x0: 1.10V<br>0x1: 1.12V<br>0x2: 1.15V<br>0x3: 1.18V                       |

### PORT TUN ONLY (0x568)

| BIT         | 7 | 6 | 5 | 4 | 3 | 2           | 1           | 0           |
|-------------|---|---|---|---|---|-------------|-------------|-------------|
| Field       | – | – | – | – | – | TUN_ONLY_2  | TUN_ONLY_1  | TUN_ONLY_CC |
| Reset       | – | – | – | – | – | 0b1         | 0b1         | 0b0         |
| Access Type | – | – | – | – | – | Write, Read | Write, Read | Write, Read |

| BITFIELD    | BITS | DESCRIPTION   | DECODE                                 |
|-------------|------|---|--|
| TUN_ONLY_2  | 2    | Disable control channel access from RX2/SDA2 and TX2/SCL2 | 0x0: CC and Tunnel<br>0x1: Tunnel only |
| TUN_ONLY_1  | 1    | Disable control channel access from RX1/SDA1 and TX1/SCL1 | 0x0: CC and Tunnel<br>0x1: Tunnel only |
| TUN_ONLY_CC | 0    | Disable control channel access from RX/SDA and TX/SCL     | 0x0: CC and Tunnel<br>0x1: Tunnel only |

### UNLOCK KEY (0x569)

| BIT         | 7               | 6 | 5 | 4 | 3 | 2 | 1 | 0 |
|-------------|-----------------|---|---|---|---|---|---|---|
| Field       | UNLOCK_KEY[7:0] |   |   |   |   |   |   |   |
| Reset       | 0xAA            |   |   |   |   |   |   |   |
| Access Type | Write, Read     |   |   |   |   |   |   |   |

| BITFIELD   | BITS | DESCRIPTION   | DECODE   |
|------------|------|---|--|
| UNLOCK_KEY | 7:0  | Register must be at unlock value to enable write access to port control pins DIS_LOCAL_CC, IIC_1_EN, IIC_2_EN, UART_1_EN, UART_2_EN, TUN_ONLY_CC, TUN_ONLY_1, and TUN_ONLY_2. | 0xAA: Unlock write access<br>Others: Lock write access |

| BITFIELD | BITS | DESCRIPTION           | DECODE |
|----------|------|-----------------------|--------|
|          |      | Defaults to unlocked. |        |

**PIO SLEW 0 (0x570)**

| BIT         | 7               | 6 | 5               | 4 | 3               | 2 | 1               | 0 |
|-------------|-----------------|---|-----------------|---|-----------------|---|-----------------|---|
| Field       | PIO03_SLEW[1:0] |   | PIO02_SLEW[1:0] |   | PIO01_SLEW[1:0] |   | PIO00_SLEW[1:0] |   |
| Reset       | 0b11            |   | 0b11            |   | 0b11            |   | 0b10            |   |
| Access Type | Write, Read     |   | Write, Read     |   | Write, Read     |   | Write, Read     |   |

| BITFIELD   | BITS | DESCRIPTION   |
|------------|------|---|
| PIO03_SLEW | 7:6  | Rise and fall time speed setting on pad ring for this PIO.<br>00 value is the fastest rise and fall time, and 11 value is the slowest.<br>This PIO corresponds to MFP3. |
| PIO02_SLEW | 5:4  | Rise and fall time speed setting on pad ring for this PIO.<br>00 value is the fastest rise and fall time, and 11 value is the slowest.<br>This PIO corresponds to MFP2. |
| PIO01_SLEW | 3:2  | Rise and fall time speed setting on pad ring for this PIO.<br>00 value is the fastest rise and fall time, and 11 value is the slowest.<br>This PIO corresponds to MFP1. |
| PIO00_SLEW | 1:0  | Rise and fall time speed setting on pad ring for this PIO.<br>00 value is the fastest rise and fall time, and 11 value is the slowest.<br>This PIO corresponds to MFP0. |

**PIO SLEW 1 (0x571)**

| BIT         | 7               | 6 | 5 | 4 | 3 | 2 | 1               | 0 |
|-------------|-----------------|---|---|---|---|---|-----------------|---|
| Field       | PIO07_SLEW[1:0] |   | – | – | – | – | PIO04_SLEW[1:0] |   |
| Reset       | 0b10            |   | – | – | – | – | 0b11            |   |
| Access Type | Write, Read     |   | – | – | – | – | Write, Read     |   |

| BITFIELD   | BITS | DESCRIPTION   |
|------------|------|---|
| PIO07_SLEW | 7:6  | Rise and fall time speed setting on pad ring for this PIO.<br>00 value is the fastest rise and fall time, and 11 value is the slowest.<br>This PIO corresponds to MFP5. |

| BITFIELD   | BITS | DESCRIPTION   |
|------------|------|---|
| PIO04_SLEW | 1:0  | Rise and fall time speed setting on pad ring for this PIO.<br>00 value is the fastest rise and fall time, and 11 value is the slowest.<br>This PIO corresponds to MFP4. |

**PIO SLEW 2 (0x572)**

| BIT         | 7 | 6 | 5 | 4 | 3 | 2 | 1               | 0 |
|-------------|---|---|---|---|---|---|-----------------|---|
| Field       | – | – | – | – | – | – | PIO08_SLEW[1:0] |   |
| Reset       | – | – | – | – | – | – | 0b10            |   |
| Access Type | – | – | – | – | – | – | Write, Read     |   |

| BITFIELD   | BITS | DESCRIPTION   |
|------------|------|---|
| PIO08_SLEW | 1:0  | Rise and fall time speed setting on pad ring for this PIO.<br>00 value is the fastest rise and fall time, and 11 value is the slowest.<br>This PIO corresponds to MFP6. |

**HS VS ACT Y (0x575)**

| BIT         | 7 | 6         | 5         | 4         | 3 | 2 | 1         | 0         |
|-------------|---|-----------|-----------|-----------|---|---|-----------|-----------|
| Field       | – | DE_DET_Y  | VS_DET_Y  | HS_DET_Y  | – | – | VS_POL_Y  | HS_POL_Y  |
| Reset       | – | 0b0       | 0b0       | 0b0       | – | – | 0b0       | 0b0       |
| Access Type | – | Read Only | Read Only | Read Only | – | – | Read Only | Read Only |

| BITFIELD | BITS | DESCRIPTION             | DECODE   |
|----------|------|-------------------------|--|
| DE_DET_Y | 6    | DE activity is detected | 0x0: DE is not detected<br>0x1: DE is detected |
| VS_DET_Y | 5    | VS activity is detected | 0x0: VS is not detected<br>0x1: VS is detected |
| HS_DET_Y | 4    | HS activity is detected | 0x0: HS is not detected<br>0x1: HS is detected |
| VS_POL_Y | 1    | Detected VS polarity    | 0x0: Active low<br>0x1: Active high            |
| HS_POL_Y | 0    | Detected HS polarity    | 0x0: Active low<br>0x1: Active high            |

**HS VS ACT Z (0x576)**

| BIT | 7 | 6 | 5 | 4 | 3 | 2 | 1 | 0 |
|-----|---|---|---|---|---|---|---|---|
|-----|---|---|---|---|---|---|---|---|

|                    |   |           |           |           |   |   |           |           |
|--------------------|---|-----------|-----------|-----------|---|---|-----------|-----------|
| <b>Field</b>       | – | DE_DET_Z  | VS_DET_Z  | HS_DET_Z  | – | – | VS_POL_Z  | HS_POL_Z  |
| <b>Reset</b>       | – | 0b0       | 0b0       | 0b0       | – | – | 0b0       | 0b0       |
| <b>Access Type</b> | – | Read Only | Read Only | Read Only | – | – | Read Only | Read Only |

| <b>BITFIELD</b> | <b>BITS</b> | <b>DESCRIPTION</b>      | <b>DECODE</b>                                  |
|-----------------|-------------|-------------------------|--|
| DE_DET_Z        | 6           | DE activity is detected | 0x0: DE is not detected<br>0x1: DE is detected |
| VS_DET_Z        | 5           | VS activity is detected | 0x0: VS is not detected<br>0x1: VS is detected |
| HS_DET_Z        | 4           | HS activity is detected | 0x0: HS is not detected<br>0x1: HS is detected |
| VS_POL_Z        | 1           | Detected VS polarity    | 0x0: Active low<br>0x1: Active high            |
| HS_POL_Z        | 0           | Detected HS polarity    | 0x0: Active low<br>0x1: Active high            |

### DP\_ORSTB\_CTL (0x577)

|                    |   |                   |                    |                   |                  |                |   |   |
|--------------------|---|-------------------|--------------------|-------------------|------------------|----------------|---|---|
| <b>BIT</b>         | 7 | 6                 | 5                  | 4                 | 3                | 2              | 1 | 0 |
| <b>Field</b>       | – | DP_RST_MIPI3_CHKB | DP_RST_STABLE_CHKB | DP_RST_MIPI2_CHKB | DP_RST_MIPI_CHKB | DP_RST_VP_CHKB | – | – |
| <b>Reset</b>       | – | 0b1               | 0b1                | 0b0               | 0b0              | 0b0            | – | – |
| <b>Access Type</b> | – | Write, Read       | Write, Read        | Write, Read       | Write, Read      | Write, Read    | – | – |

| <b>BITFIELD</b>    | <b>BITS</b> | <b>DESCRIPTION</b>   | <b>DECODE</b>  |
|--------------------|-------------|--|--|
| DP_RST_MIPI3_CHKB  | 6           | Select reset mode to MIPI controllers. Set this bit to 1, if required, to have completely independent resets, and linkup of Link A and Link B.     | 0x0: Legacy<br>0x1: Enable auto reset of command FIFO read pointer (controls line memory output to MIPI TX) in MIPI TX           |
| DP_RST_STABLE_CHKB | 5           | Select reset mode when changing register values.   | 0x0: Legacy<br>0x1: Prevent resets while control register values are changing  |
| DP_RST_MIPI2_CHKB  | 4           | Select reset mode to MIPI controllers. Set this bit to 1, if required, to have completely independent resets, and linkup of Link A and Link B.     | 0x0: Legacy<br>0x1: Independent reset functionality. Enable auto reset of MIPI controllers.                                      |
| DP_RST_MIPI_CHKB   | 3           | Select reset mode to MIPI controllers.   | 0x0: Legacy<br>0x1: Independent reset functionality. This enables RST_MIPITX_LOC[3:0] (0x33F) to reset controllers individually. |
| DP_RST_VP_CHKB     | 2           | Select reset mode to VIDEO_RX, VRX blocks. Set this bit to 1, if required, to have completely independent resets, and linkup of Link A and Link B. | 0x0: Legacy<br>0x1: Independent reset functionality  |

**PM\_OV\_STAT2 (0x578)**

| BIT         | 7            | 6           | 5                   | 4 | 3 | 2 | 1                  | 0 |
|-------------|--------------|-------------|---------------------|---|---|---|--------------------|---|
| Field       | VTERM_OV_OEN | VREG_OV_OEN | VTERM_OV_LEVEL[1:0] |   | – | – | VREG_OV_LEVEL[1:0] |   |
| Reset       | 0b0          | 0b0         | 0b01                |   | – | – | 0b01               |   |
| Access Type | Write, Read  | Write, Read | Write, Read         |   | – | – | Write, Read        |   |

| BITFIELD       | BITS | DESCRIPTION   | DECODE   |
|----------------|------|---|--|
| VTERM_OV_OEN   | 7    | Enable $V_{\text{TERM}}$ overvoltage status on ERRB                                 | 0b0: Reporting disabled<br>0b1: Reporting enabled        |
| VREG_OV_OEN    | 6    | Enable $V_{\text{REG}}$ (LDO regulated $V_{\text{DD}}$ ) overvoltage status on ERRB | 0b0: Reporting disabled<br>0b1: Reporting enabled        |
| VTERM_OV_LEVEL | 5:4  | $V_{\text{TERM}}$ overvoltage comparator trip level                                 | 0x0: 1.32V<br>0x1: 1.35V<br>0x2: 1.38V<br>0x3: 1.41V     |
| VREG_OV_LEVEL  | 1:0  | $V_{\text{REG}}$ (LDO regulated $V_{\text{DD}}$ ) overvoltage comparator trip level | 0x0: 1.32 V<br>0x1: 1.35 V<br>0x2: 1.38 V<br>0x3: 1.41 V |

**PM\_OV\_STAT3 (0x579)**

| BIT         | 7               | 6               | 5 | 4 | 3 | 2 | 1 | 0 |
|-------------|-----------------|-----------------|---|---|---|---|---|---|
| Field       | VTERM_OV_FLAG   | VREG_OV_FLAG    | – | – | – | – | – | – |
| Reset       | 0b0             | 0b0             | – | – | – | – | – | – |
| Access Type | Read Clears All | Read Clears All | – | – | – | – | – | – |

| BITFIELD      | BITS | DESCRIPTION   | DECODE   |
|---------------|------|---|--|
| VTERM_OV_FLAG | 7    | Sticky status value for $V_{\text{TERM}}$ overvoltage                                 | 0b0: Overvoltage condition not detected<br>0b1: Overvoltage condition detected |
| VREG_OV_FLAG  | 6    | Sticky status value for $V_{\text{REG}}$ (LDO regulated $V_{\text{DD}}$ ) overvoltage | 0b0: Overvoltage condition not detected<br>0b1: Overvoltage condition detected |

**UART\_0 (0x808)**

| BIT         | 7 | 6 | 5           | 4           | 3 | 2                | 1 | 0           |
|-------------|---|---|-------------|-------------|---|------------------|---|-------------|
| Field       | – | – | REM_MS_EN_1 | LOC_MS_EN_1 | – | BYPASS_TO_1[1:0] |   | BYPASS_EN_1 |
| Reset       | – | – | 0b0         | 0b0         | – | 0b01             |   | 0b0         |
| Access Type | – | – | Write, Read | Write, Read | – | Write, Read      |   | Write, Read |

| BITFIELD    | BITS | DESCRIPTION   | DECODE   |
|-------------|------|---|--|
| REM_MS_EN_1 | 5    | Enable UART Bypass mode control by remote GPIO pin.<br><br>When set, remote chip's GPIO is used as MS pin (UART mode select). When MS is high, chip is in Bypass mode; otherwise, chip is in Base mode.   | 0b0: UART bypass mode not controlled by remote MS pin<br>0b1: UART bypass mode controlled by remote MS pin |
| LOC_MS_EN_1 | 4    | Enable UART Bypass mode control by local GPIO pin.<br><br>Set to use GPIO2 pin as MS pin (UART mode select). When MS is high, chip is in Bypass mode; otherwise, chip is in Base mode.  | 0b0: UART bypass mode not controlled by local MS pin<br>0b1: UART bypass mode controlled by local MS pin   |
| BYPASS_TO_1 | 2:1  | UART soft-bypass timeout duration.<br><br>When set to 11, BYPASS_EN is never cleared, so the device stays in Bypass mode until next power down.   | 0b00: 2ms<br>0b01: 8ms<br>0b10: 32ms<br>0b11: Disabled   |
| BYPASS_EN_1 | 0    | Enable UART soft-bypass mode.<br><br>Bypass mode remains active as long as there is UART activity. When there is no UART activity for selected duration (configured by BYPASS_TO bitfield), device exits Bypass mode, and the bit is automatically cleared. | 0b0: UART soft-bypass mode disabled<br>0b1: UART soft-bypass mode enabled                                  |

### UART 1 (0x809)

| BIT         | 7 | 6 | 5           | 4           | 3 | 2                | 1 | 0           |
|-------------|---|---|-------------|-------------|---|------------------|---|-------------|
| Field       | – | – | REM_MS_EN_2 | LOC_MS_EN_2 | – | BYPASS_TO_2[1:0] |   | BYPASS_EN_2 |
| Reset       | – | – | 0b0         | 0b0         | – | 0b01             |   | 0b0         |
| Access Type | – | – | Write, Read | Write, Read | – | Write, Read      |   | Write, Read |

| BITFIELD    | BITS | DESCRIPTION   | DECODE   |
|-------------|------|---|--|
| REM_MS_EN_2 | 5    | Enable UART Bypass mode control by remote GPIO pin.<br><br>When set, remote chip's GPIO is used as MS pin (UART mode select). When MS is high, chip is in Bypass mode; otherwise, chip is in Base mode. | 0b0: UART bypass mode not controlled by remote MS pin<br>0b1: UART bypass mode controlled by remote MS pin |
| LOC_MS_EN_2 | 4    | Enable UART Bypass mode control by local GPIO pin.<br><br>Set to use GPIO2 pin as MS pin (UART mode   | 0b0: UART bypass mode not controlled by local MS pin<br>0b1: UART bypass mode controlled by local MS pin   |

| BITFIELD    | BITS | DESCRIPTION   | DECODE  |
|-------------|------|---|---|
|             |      | select). When MS is high, chip is in Bypass mode; otherwise, chip is in Base mode.  |   |
| BYPASS_TO_2 | 2:1  | UART soft-bypass timeout duration.<br><br>When set to 11, BYPASS_EN is never cleared, so the device stays in bypass mode until next power-down.   | 0b00: 2ms<br>0b01: 8ms<br>0b10: 32ms<br>0b11: Disabled                    |
| BYPASS_EN_2 | 0    | Enable UART Soft-bypass mode.<br><br>Bypass mode remains active as long as there is UART activity. When there is no UART activity for selected duration (configured by BYPASS_TO bitfield), device exits Bypass mode, and the bit is automatically cleared. | 0b0: UART soft-bypass mode disabled<br>0b1: UART soft-bypass mode enabled |

**I2C\_PT\_0 (0x80E)**

| BIT         | 7 | 6                      | 5 | 4 | 3 | 2                      | 1 | 0 |
|-------------|---|------------------------|---|---|---|------------------------|---|---|
| Field       | – | I2C_REGSLV_0_TIMED_OUT | – | – | – | I2C_INTREG_SLV_TO[2:0] |   |   |
| Reset       | – | 0b0                    | – | – | – | 0b110                  |   |   |
| Access Type | – | Read Only              | – | – | – | Write, Read            |   |   |

| BITFIELD               | BITS | DESCRIPTION  | DECODE   |
|------------------------|------|--|--|
| I2C_REGSLV_0_TIMED_OUT | 6    | Internal I <sup>2</sup> C-to-Register subordinate for Primary Control Channel timed out while waiting for the main or the internal register access FSM.  | 0x0: Internal I <sup>2</sup> C-to-Register subordinate for Primary Control Channel 0 has not timed out<br>0x1: Internal I <sup>2</sup> C-to-Register subordinate for Primary Control Channel 0 has timed out |
| I2C_INTREG_SLV_TO      | 2:0  | I <sup>2</sup> C-to-Internal Register Subordinate 0 Timeout Setting<br><br>Internal register I <sup>2</sup> C subordinate 0 times out after the configured duration if it does not receive any response from the external main or internal register FSM. This subordinate serves the I <sup>2</sup> C Primary Control Channel. | 0b000: 1ms<br>0b001: 2ms<br>0b010: 4ms<br>0b011: 8ms<br>0b100: 16ms<br>0b101: 32ms<br>0b110: 35ms<br>0b111: Disabled   |

**I2C\_PT\_1 (0x80F)**

| BIT   | 7                      | 6                      | 5                        | 4 | 3 | 2                        | 1 | 0 |
|-------|------------------------|------------------------|--------------------------|---|---|--------------------------|---|---|
| Field | I2C_REGSLV_2_TIMED_OUT | I2C_REGSLV_1_TIMED_OUT | I2C_INTREG_SLV_2_TO[2:0] |   |   | I2C_INTREG_SLV_1_TO[2:0] |   |   |

|                    |           |           |             |             |
|--------------------|-----------|-----------|-------------|-------------|
| <b>Reset</b>       | 0b0       | 0b0       | 0b110       | 0b110       |
| <b>Access Type</b> | Read Only | Read Only | Write, Read | Write, Read |

| <b>BITFIELD</b>        | <b>BITS</b> | <b>DESCRIPTION</b>   | <b>DECODE</b>  |
|------------------------|-------------|--|--|
| I2C_REGSLV_2_TIMED_OUT | 7           | Internal I <sup>2</sup> C-to-Register subordinate for Pass-Through Port 2 timed out while waiting for the main or the internal register access FSM.  | 0x0: Internal I <sup>2</sup> C-to-Register subordinate for Pass-Through Port 2 has not timed out<br>0x1: Internal I <sup>2</sup> C-to-Register subordinate for Pass-Through Port 2 has timed out |
| I2C_REGSLV_1_TIMED_OUT | 6           | Internal I <sup>2</sup> C-to-Register subordinate for Pass-Through Port 1 timed out while waiting for the main or the internal register access FSM.  | 0x0: Internal I <sup>2</sup> C-to-Register subordinate for Pass-Through Port 1 has not timed out<br>0x1: Internal I <sup>2</sup> C-to-Register subordinate for Pass-Through Port 1 has timed out |
| I2C_INTREG_SLV_2_TO    | 5:3         | I <sup>2</sup> C-to-Internal Register Subordinate 2 timeout setting<br><br>Internal register I <sup>2</sup> C subordinate 2 times out after the configured duration if it does not receive any response from the external main or internal register FSM. This subordinate serves the I <sup>2</sup> C Pass-Through Port 2. | 0b000: 1ms<br>0b001: 2ms<br>0b010: 4ms<br>0b011: 8ms<br>0b100: 16ms<br>0b101: 32ms<br>0b110: 35ms<br>0b111: Disabled   |
| I2C_INTREG_SLV_1_TO    | 2:0         | I <sup>2</sup> C-to-Internal Register Subordinate 1 Timeout Setting<br><br>Internal register I <sup>2</sup> C subordinate 1 times out after the configured duration if it does not receive any response from the external main or internal register FSM. This subordinate serves the I <sup>2</sup> C Pass-Through Port 1. | 0b000: 1ms<br>0b001: 2ms<br>0b010: 4ms<br>0b011: 8ms<br>0b100: 16ms<br>0b101: 32ms<br>0b110: 35ms<br>0b111: Disabled   |

**GMSL1\_2 (0xB02)**

|                    |          |          |          |          |          |          |             |          |
|--------------------|----------|----------|----------|----------|----------|----------|-------------|----------|
| <b>BIT</b>         | <b>7</b> | <b>6</b> | <b>5</b> | <b>4</b> | <b>3</b> | <b>2</b> | <b>1</b>    | <b>0</b> |
| <b>Field</b>       | –        | –        | –        | –        | –        | –        | SRNG[1:0]   |          |
| <b>Reset</b>       | –        | –        | –        | –        | –        | –        | 0b11        |          |
| <b>Access Type</b> | –        | –        | –        | –        | –        | –        | Write, Read |          |

| <b>BITFIELD</b> | <b>BITS</b> | <b>DESCRIPTION</b>     | <b>DECODE</b>  |
|-----------------|-------------|------------------------|--|
| SRNG            | 1:0         | Serial data rate range | 0x0: 0.5 to 1Gbps<br>0x1: 1 to 1.5Gbps<br>0x2: 1.5 to 3.125Gbps<br>0x3: Autodetect |

**GMSL1\_4 (0xB04)**

| BIT         | 7 | 6           | 5           | 4                | 3 | 2 | 1           | 0           |
|-------------|---|-------------|-------------|------------------|---|---|-------------|-------------|
| Field       | – | OUTENB      | PRBSEN      | CC_PORT_SEL[1:0] |   | – | REVCCEN     | FWDCEN      |
| Reset       | – | 0b0         | 0b0         | 0b00             |   | – | 0b1         | 0b1         |
| Access Type | – | Write, Read | Write, Read | Write, Read      |   | – | Write, Read | Write, Read |

| BITFIELD    | BITS | DESCRIPTION   | DECODE  |
|-------------|------|---|---|
| OUTENB      | 6    | Disable outputs   | 0b0: Outputs enabled<br>0b1: Outputs disabled   |
| PRBSEN      | 5    | PRBS test enable (In HIBW mode set PRBS_TYPE=0)                   | 0b0: Set device normal operation<br>0b1: Enable PRBS test   |
| CC_PORT_SEL | 4:3  | Select which I <sup>2</sup> C/UART port is connected to this link | 0x0: CC port<br>0x1: Port 0 (RX0_SDA0, TX0_SCL0)<br>0x2: Port 1 (RX1_SDA1, TX1_SCL1)<br>0x3: Reserved |
| REVCCEN     | 1    | Enable reverse control channel from deserializer                  | 0b0: Disable reverse control channel receiver<br>0b1: Enable reverse control channel receiver         |
| FWDCEN      | 0    | Enable forward control channel to deserializer                    | 0b0: Disable forward control channel transmitter<br>0b1: Enable forward control channel transmitter   |

**GMSL1\_5 (0xB05)**

| BIT         | 7           | 6           | 5           | 4           | 3           | 2 | 1 | 0 |
|-------------|-------------|-------------|-------------|-------------|-------------|---|---|---|
| Field       | I2CMETHOD   | NO_REM_MST  | HVTR_MODE   | EN_EQ       | EQTUNE[3:0] |   |   |   |
| Reset       | 0b0         | 0b0         | 0b1         | 0b1         | 0x9         |   |   |   |
| Access Type | Write, Read | Write, Read | Write, Read | Write, Read | Write, Read |   |   |   |

| BITFIELD   | BITS | DESCRIPTION   | DECODE  |
|------------|------|---|---|
| I2CMETHOD  | 7    | I <sup>2</sup> C Method - Skip register address when converting UART to I <sup>2</sup> C  | 0b0: Send the register address during UART-to-I <sup>2</sup> C conversion<br>0b1: Do not send the register address during UART-to-I <sup>2</sup> C conversion |
| NO_REM_MST | 6    | Set to 1 to indicate that there is no I <sup>2</sup> C main on remote side so this (local) chip should ignore any I <sup>2</sup> C packet initiation (start condition) from remote side |   |
| HVTR_MODE  | 5    | HV tracking allows continuous HSYNC format  | 0b0: Use partial periodic HV tracking<br>0b1: Use partial and full periodic HV tracking   |
| EN_EQ      | 4    | Enable equalizer for manual and adaptive modes  | 0b0: Disable equalization<br>0b1: Enable equalization   |

| BITFIELD | BITS | DESCRIPTION   | DECODE   |
|----------|------|---|--|
| EQTUNE   | 3:0  | Equalizer boost level at 750MHz<br>(effective when Adaptive EQ is turned off) | 0b0000: 1.6dB manual EQ setting<br>0x0001: 2.1dB manual EQ setting<br>0x0010: 2.8dB manual EQ setting<br>0x0011: 3.5dB manual EQ setting<br>0x0100: 4.3dB manual EQ setting<br>0x0101: 5.2dB manual EQ setting<br>0x0110: 6.3dB manual EQ setting<br>0x0111: 7.3dB manual EQ setting<br>0x1000: 8.5dB manual EQ setting<br>0x1001: 9.7dB manual EQ setting<br>0x1010: 11dB manual EQ setting<br>0x1011: 12.2dB manual EQ setting<br>0x1100: Reserved<br>0x1101: Reserved<br>0x1110: Reserved<br>0x1111: Reserved |

**GMSL1\_6 (0xB06)**

| BIT         | 7           | 6           | 5           | 4           | 3           | 2           | 1 | 0 |
|-------------|-------------|-------------|-------------|-------------|-------------|-------------|---|---|
| Field       | HIGHIMM     | MAX_RT_EN   | I2C_RT_EN   | GPI_COMP_EN | GPI_RT_EN   | HV_SRC[2:0] |   |   |
| Reset       | 0b0         | 0b1         | 0b1         | 0b0         | 0b1         | 0b111       |   |   |
| Access Type | Write, Read | Write, Read | Write, Read | Write, Read | Write, Read | Write, Read |   |   |

| BITFIELD    | BITS | DESCRIPTION                            | DECODE  |
|-------------|------|--|---|
| HIGHIMM     | 7    | Reverse channel high immunity mode     | 0b0: Reverse channel high immunity mode disabled<br>0b1: Reverse channel high immunity mode enabled   |
| MAX_RT_EN   | 6    | Maximum retransmission limit enable    | 0b0: Disable maximum retransmission limit<br>0b1: Enable maximum retransmission limit   |
| I2C_RT_EN   | 5    | I <sup>2</sup> C retransmission enable | 0b0: Disable I <sup>2</sup> C retransmission<br>0b1: Enable I <sup>2</sup> C retransmission enable  |
| GPI_COMP_EN | 4    | GPI skew compensation enable           | 0b0: Disable GPI skew compensation<br>0b1: Enable GPI skew compensation   |
| GPI_RT_EN   | 3    | GPI retransmission enable              | 0b0: Disable GPI retransmission<br>0b1: Enable GPI retransmission   |
| HV_SRC      | 2:0  | HV_VS bit selection                    | 0b000: Use D18/D19 for HS/VS (use this setting when the serializer is a 3.12Gbps device or if HIBW mode is used; otherwise, this setting is for use with the MAX9273 when DBL = 0 or HVEN = 1)<br>0b001: Use D14/D15 for HS/VS (for use with the MAX9271/MAX96705 when DBL = 0 or HVEN = 1)<br>0b010: Use D12/D13 for HS/VS (for use with the MAX96707 when DBL = 0 or HVEN = 1)<br>0b011: Use D0/D1 for HS/VS (for use with the MAX9271/MAX9273/MAX96705/MAX96707 when DBL = 1 and HVEN = 0)<br>0b100: Reserved<br>0b101: Reserved<br>0b110: Automatically determine the source of HSYNC/VSYNC (for use with the MAX96707)<br>0b111: Automatically determine the source of HSYNC/VSYNC (for use with the MAX96705) |

**GMSL1\_7 (0xB07)**

| BIT         | 7           | 6           | 5           | 4 | 3           | 2           | 1 | 0           |
|-------------|-------------|-------------|-------------|---|-------------|-------------|---|-------------|
| Field       | DBL         | DRS         | BWS         | – | HIBW        | HVEN        | – | PXL_CRC     |
| Reset       | 0b0         | 0b0         | 0b0         | – | 0b0         | 0b0         | – | 0b0         |
| Access Type | Write, Read | Write, Read | Write, Read | – | Write, Read | Write, Read | – | Write, Read |

| BITFIELD | BITS | DESCRIPTION   | DECODE  |
|----------|------|---|---|
| DBL      | 7    | Double-output mode  | 0b0: Use single-rate output<br>0b1: Use double-rate output (2x word rate at 1/2x width)   |
| DRS      | 6    | Data rate select  | 0b0: Use normal data rate output<br>0b1: Use 1/2 rate data output (for use with low data rates)                                       |
| BWS      | 5    | Bus width select  | 0b0: Set bus width for 22-/24-bit bus, 24-/27-bit mode (depending on HIBW setting)<br>0b1: Set bus width for 30-bit bus (32-bit mode) |
| HIBW     | 3    | High-bandwidth mode   | 0b0: Disable high-bandwidth mode<br>0b1: Enable high-bandwidth mode (when BWS = 0)  |
| HVEN     | 2    | HS/VS encoding enable   | 0b0: Disable HS/VS encoding<br>0b1: Enable HS/VS encoding   |
| PXL_CRC  | 0    | Pixel error detection type (this is controllable by pin when LCCEN=0) | 0b0: Use 1-bit parity (compatible with all devices)<br>0b1: Use 6-bit CRC   |

**GMSL1\_8 (0xB08)**

| BIT         | 7            | 6 | 5           | 4           | 3 | 2           | 1                  | 0 |
|-------------|--------------|---|-------------|-------------|---|-------------|--------------------|---|
| Field       | GPI_SEL[1:0] |   | GPI_EN      | EN_FSYNC_TX | – | PKTCC_EN    | CC_CRC_LENGTH[1:0] |   |
| Reset       | 0b00         |   | 0b1         | 0b0         | – | 0b0         | 0b01               |   |
| Access Type | Write, Read  |   | Write, Read | Write, Read | – | Write, Read | Write, Read        |   |

| BITFIELD      | BITS | DESCRIPTION   | DECODE  |
|---------------|------|---|---|
| GPI_SEL       | 7:6  | Select GPI pin to transmit to Serializer            | 0x0: GPI_0<br>0x1: GPI_1<br>0x2: GPI_2<br>0x3: GPI_3  |
| GPI_EN        | 5    | Enable GPI-to-GPO signal transmission to serializer | 0b0: Disable GPI-to-GPO transmission<br>0b1: Enable GPI-to-GPO transmission                     |
| EN_FSYNC_TX   | 4    | Enable frame sync signal transmission               |   |
| PKTCC_EN      | 2    | Packet-based control-channel mode enable            | 0b0: Disable packet-based control-channel mode<br>0b1: Enable packet-based control-channel mode |
| CC_CRC_LENGTH | 1:0  | Control channel CRC length                          | 0b00: 1-bit CRC<br>0b01: 5-bit CRC<br>0b10: 8-bit CRC<br>0b11: Reserved                         |

**GMSL1 D (0xB0D)**

| BIT         | 7           | 6 | 5 | 4 | 3 | 2              | 1 | 0 |
|-------------|-------------|---|---|---|---|----------------|---|---|
| Field       | I2C_LOC_ACK | – | – | – | – | HS_TRACK_FSYNC | – | – |
| Reset       | 0b0         | – | – | – | – | 0b0            | – | – |
| Access Type | Write, Read | – | – | – | – | Write, Read    | – | – |

| BITFIELD       | BITS | DESCRIPTION   | DECODE  |
|----------------|------|---|---|
| I2C_LOC_ACK    | 7    | Enable I <sup>2</sup> C-to-I <sup>2</sup> C subordinate local acknowledge when forward channel is not available | 0b0: Disable local acknowledge when forward channel is not available<br>0b1: Enable local acknowledge when forward channel is not available |
| HS_TRACK_FSYNC | 2    | 0 = Allow infinite length vertical blanking<br>1 = Lose HLOCKED with VLOCKED                                    |   |

**GMSL1 E (0xB0E)**

| BIT         | 7            | 6 | 5 | 4 | 3 | 2 | 1 | 0 |
|-------------|--------------|---|---|---|---|---|---|---|
| Field       | DET_THR[7:0] |   |   |   |   |   |   |   |
| Reset       | 0x00         |   |   |   |   |   |   |   |
| Access Type | Write, Read  |   |   |   |   |   |   |   |

| BITFIELD | BITS | DESCRIPTION                   | DECODE  |
|----------|------|-------------------------------|---|
| DET_THR  | 7:0  | Threshold for detected errors | 0xXX: Number of errors for detected error threshold |

**GMSL1 F (0xB0F)**

| BIT         | 7 | 6           | 5           | 4           | 3           | 2 | 1 | 0           |
|-------------|---|-------------|-------------|-------------|-------------|---|---|-------------|
| Field       | – | EN_DE_FILT  | EN_HS_FILT  | EN_VS_FILT  | DE_EN       | – | – | PRBS_TYPE   |
| Reset       | – | 0b0         | 0b0         | 0b0         | 0b1         | – | – | 0b1         |
| Access Type | – | Write, Read | Write, Read | Write, Read | Write, Read | – | – | Write, Read |

| BITFIELD   | BITS | DESCRIPTION                   | DECODE  |
|------------|------|-------------------------------|---|
| EN_DE_FILT | 6    | Enable glitch filtering on DE | 0b0: Disable DE glitch filtering<br>0b1: Enable DE glitch filtering |
| EN_HS_FILT | 5    | Enable glitch filtering on HS | 0b0: Disable HS glitch filtering<br>0b1: Enable HS glitch filtering |

| BITFIELD   | BITS | DESCRIPTION  | DECODE  |
|------------|------|--|---|
| EN_VS_FILT | 4    | Enable glitch filtering on VS  | 0b0: Disable VS glitch filtering<br>0b1: Enable VS glitch filtering                   |
| DE_EN      | 3    | Enable processing separate HS and DE signals   | 0b0: Disable processing HS and DE signals<br>0b1: Enable processing HS and DE signals |
| PRBS_TYPE  | 0    | PRBS type select (in HIBW mode set PRBS_TYPE = 0) PRBS_TYPE setting must match in serializer and deserializer. | 0b0: GMSL1 Legacy style PRBS test<br>0b1: Non-GMSL1 Legacy style PRBS test            |

**GMSL1 10 (0xB10)**

| BIT         | 7              | 6 | 5           | 4                 | 3 | 2 | 1           | 0 |
|-------------|----------------|---|-------------|-------------------|---|---|-------------|---|
| Field       | RCEG_TYPE[1:0] |   | RCEG_BOUND  | RCEG_ERR_NUM[3:0] |   |   | RCEG_EN     |   |
| Reset       | 0b00           |   | 0b0         | 0x1               |   |   | 0b0         |   |
| Access Type | Write, Read    |   | Write, Read | Write, Read       |   |   | Write, Read |   |

| BITFIELD     | BITS | DESCRIPTION   | DECODE  |
|--------------|------|---|---|
| RCEG_TYPE    | 7:6  | Reverse channel generated error type  | 0b00: Random<br>0b01: Short burst<br>0b10: Long burst<br>0b11: Long burst                           |
| RCEG_BOUND   | 5    | Reverse channel generated error boundary (Effective when RCEG_TYPE = 0x)          | 0b0: Errors are unbounded to symbols<br>0b1: Errors are bounded to symbols                          |
| RCEG_ERR_NUM | 4:1  | Number of RCEG errors generated with each request (Effective when RCEG_TYPE = 0x) | 0xX: Number of errors generated per request   |
| RCEG_EN      | 0    | Enable reverse channel error generator  | 0b0: Disable reverse channel error generator<br>0b1: Enable reverse channel error generator enabled |

**GMSL1 11 (0xB11)**

| BIT         | 7                  | 6 | 5 | 4 | 3                    | 2 | 1                    | 0 |
|-------------|--------------------|---|---|---|----------------------|---|----------------------|---|
| Field       | RCEG_ERR_RATE[3:0] |   |   |   | RCEG_LO_BST_PRB[1:0] |   | RCEG_LO_BST_LEN[1:0] |   |
| Reset       | 0xF                |   |   |   | 0b00                 |   | 0b00                 |   |
| Access Type | Write, Read        |   |   |   | Write, Read          |   | Write, Read          |   |

| BITFIELD        | BITS | DESCRIPTION  | DECODE   |
|-----------------|------|--|--|
| RCEG_ERR_RATE   | 7:4  | Error generation rate in terms of bit time = $2^{-(RCEG\_ERR\_RATE+3)}$ ,<br>(Effective when RCEG_TYPE = 0x) | 0x0: Rate is $2^{-3}$<br>0x1: Rate is $2^{-4}$<br>0x2: Rate is $2^{-5}$<br>...<br>0xF: Rate is $2^{-18}$ |
| RCEG_LO_BST_PRB | 3:2  | Long burst error probability. Effective when RCEG_TYPE = 10.   | 0b00: 1/1024<br>0b01: 1/128<br>0b10: 1/32<br>0b11: 1/8   |
| RCEG_LO_BST_LEN | 1:0  | Long burst error length in terms of bit time. Effective when RCEG_TYPE = 10.                                 | 0b00: <b>Continuous</b><br>0b01: 128 (~150µs)<br>0b10: 8192 (~9.83ms)<br>0b11: 1048576 (~1.26s)          |

**GMSL1 12 (0xB12)**

| BIT         | 7 | 6             | 5                 | 4                 | 3 | 2             | 1               | 0 |
|-------------|---|---------------|-------------------|-------------------|---|---------------|-----------------|---|
| Field       | – | CC_CRC_ERR_EN | LINE_CRC_LOC[1:0] | LINE_CRC_EN_GMSL1 | – | MAX_RT_ERR_EN | RCEG_ERR_PER_EN |   |
| Reset       | – | 0b1           | 0b01              | 0b0               | – | 0b1           | 0b0             |   |
| Access Type | – | Write, Read   | Write, Read       | Write, Read       | – | Write, Read   | Write, Read     |   |

| BITFIELD          | BITS | DESCRIPTION   | DECODE  |
|-------------------|------|---|---|
| CC_CRC_ERR_EN     | 6    | Enable reporting of (CC_CRC_ERR_CNT > 0) on the ERRORB pin          | 0b0: Disable reporting of errors on ERRORB<br>0b1: Enable reporting of errors on ERRORB                                 |
| LINE_CRC_LOC      | 5:4  | Video line CRC insertion location                                   | 0b00: [1..4]<br>0x01: [5..8]<br>0x10: [9..12]<br>0x11: [13..16]   |
| LINE_CRC_EN_GMSL1 | 3    | Video line CRC enable   | 0b0: Disable video line CRC<br>0x1: Enable video line CRC   |
| MAX_RT_ERR_EN     | 1    | Enable reflection of maximum retransmission error on the ERRORB pin | 0b0: Disable maximum retransmission error on the ERROR pin<br>0b1: Enable maximum retransmission error on the ERROR pin |
| RCEG_ERR_PER_EN   | 0    | Periodic error generation enable. Effective when RCEG_TYPE = 0x.    | 0b0: Disable periodic error generator<br>0b1: Enable periodic error generator   |

**GMSL1 13 (0xB13)**

| BIT   | 7         | 6               | 5                  | 4                   | 3 | 2 | 1 | 0 |
|-------|-----------|-----------------|--------------------|---------------------|---|---|---|---|
| Field | EOM_EN_G1 | EOM_PER_MODE_G1 | EOM_MAN_TRG_REQ_G1 | EOM_MIN_THR_G1[4:0] |   |   |   |   |
| Reset | 0b1       | 0b1             | 0b0                | 0b00000             |   |   |   |   |

|                    |             |             |             |             |
|--------------------|-------------|-------------|-------------|-------------|
| <b>Access Type</b> | Write, Read | Write, Read | Write, Read | Write, Read |
|--------------------|-------------|-------------|-------------|-------------|

| BITFIELD           | BITS | DESCRIPTION   | DECODE   |
|--------------------|------|---|--|
| EOM_EN_G1          | 7    | Eye-opening monitor enable  | 0b0: Disable EOM<br>0x1: Enable EOM  |
| EOM_PER_MODE_G1    | 6    | Eye-opening monitor periodic mode select  | 0b0: Set EOM to use nonperiodic mode<br>0x1: Set EOM to use periodic mode      |
| EOM_MAN_TRG_REQ_G1 | 5    | Eye-opening monitor (EOM) manual trigger request. Valid on the rising edge of this bit when not in periodic mode. | 0x0: Do not trigger EOM.<br>0x1: Manually trigger the EOM                      |
| EOM_MIN_THR_G1     | 4:0  | Eye-opening minimum threshold (in terms of percent) for flagging ERRORB pin                                       | 0b00000: Disabled<br>0b00001: 3.125%<br>0b00010: 6.25%<br>...<br>0b11111: 100% |

**GMSL1 14 (0xB14)**

|                    |             |              |                 |                  |          |          |          |          |
|--------------------|-------------|--------------|-----------------|------------------|----------|----------|----------|----------|
| <b>BIT</b>         | <b>7</b>    | <b>6</b>     | <b>5</b>        | <b>4</b>         | <b>3</b> | <b>2</b> | <b>1</b> | <b>0</b> |
| <b>Field</b>       | AEQ_EN      | AEQ_PER_MODE | AEQ_MAN_TRG_REQ | EOM_PER_THR[4:0] |          |          |          |          |
| <b>Reset</b>       | 0b1         | 0b0          | 0b0             | 0b00000          |          |          |          |          |
| <b>Access Type</b> | Write, Read | Write, Read  | Write, Read     | Write, Read      |          |          |          |          |

| BITFIELD        | BITS | DESCRIPTION   | DECODE  |
|-----------------|------|---|---|
| AEQ_EN          | 7    | Adaptive equalization enable  | 0b0: Disable AEQ<br>0x1: Enable AEQ   |
| AEQ_PER_MODE    | 6    | Adaptive equalizer periodic mode select   | 0b0: Set AEQ to use nonperiodic mode<br>0x1: Set AEQ to use periodic mode   |
| AEQ_MAN_TRG_REQ | 5    | Adaptive equalizer manual fine-tune request enable. Valid on the rising edge of this bit when not in periodic mode. | 0x0: Do not trigger AEQ fine-tuning<br>0x1: Manually trigger the AEQ fine-tuning  |
| EOM_PER_THR     | 4:0  | Eye-opening threshold to trigger a fine-tune operation  | eye-opening<br><br>0b00000: Eye-opening threshold is disabled<br>0b10000: 50% eye-opening triggers fine-tune operation<br>OTHER: Reserved |

**GMSL1 15 (0xB15)**

|              |              |          |          |          |          |          |          |          |
|--------------|--------------|----------|----------|----------|----------|----------|----------|----------|
| <b>BIT</b>   | <b>7</b>     | <b>6</b> | <b>5</b> | <b>4</b> | <b>3</b> | <b>2</b> | <b>1</b> | <b>0</b> |
| <b>Field</b> | DET_ERR[7:0] |          |          |          |          |          |          |          |

|                    |           |
|--------------------|-----------|
| <b>Reset</b>       | 0x00      |
| <b>Access Type</b> | Read Only |

| <b>BITFIELD</b> | <b>BITS</b> | <b>DESCRIPTION</b>     | <b>DECODE</b>                   |
|-----------------|-------------|------------------------|---------------------------------|
| DET_ERR         | 7:0         | Detected error counter | 0xXX: Number of detected errors |

**GMSL1\_16 (0xB16)**

| <b>BIT</b>         | <b>7</b>      | <b>6</b> | <b>5</b> | <b>4</b> | <b>3</b> | <b>2</b> | <b>1</b> | <b>0</b> |
|--------------------|---------------|----------|----------|----------|----------|----------|----------|----------|
| <b>Field</b>       | PRBS_ERR[7:0] |          |          |          |          |          |          |          |
| <b>Reset</b>       | 0x00          |          |          |          |          |          |          |          |
| <b>Access Type</b> | Read Only     |          |          |          |          |          |          |          |

| <b>BITFIELD</b> | <b>BITS</b> | <b>DESCRIPTION</b> | <b>DECODE</b>                        |
|-----------------|-------------|--------------------|--------------------------------------|
| PRBS_ERR        | 7:0         | PRBS error counter | 0xXX: Number of detected PRBS errors |

**GMSL1\_17 (0xB17)**

| <b>BIT</b>         | <b>7</b>            | <b>6</b>       | <b>5</b>  | <b>4</b>  | <b>3</b>       | <b>2</b> | <b>1</b> | <b>0</b> |
|--------------------|---------------------|----------------|-----------|-----------|----------------|----------|----------|----------|
| <b>Field</b>       | I2C_TIMED_OUT_GMSL1 | MAX_RT_ERR_I2C | PRBS_OK   | GPI_IN    | MAX_RT_ERR_GPI | –        | –        | –        |
| <b>Reset</b>       | 0b0                 | 0b0            | 0b0       | 0b0       | 0b0            | –        | –        | –        |
| <b>Access Type</b> | Read Only           | Read Only      | Read Only | Read Only | Read Only      | –        | –        | –        |

| <b>BITFIELD</b>     | <b>BITS</b> | <b>DESCRIPTION</b>  | <b>DECODE</b>  |
|---------------------|-------------|---|--|
| I2C_TIMED_OUT_GMSL1 | 7           | I <sup>2</sup> C channel timed out flag   | 0b0: I <sup>2</sup> C channel not timed out<br>0b1: I <sup>2</sup> C channel timed out                                 |
| MAX_RT_ERR_I2C      | 6           | Maximum retransmission error flag. Cleared when read.   | 0b0: No control-channel retransmission error<br>0b1: Control-channel retransmission maximum limit reached              |
| PRBS_OK             | 5           | MAX9271/73 compatible PRBS test for link is completed normally. Check PRBS_ERR register for the PRBS success. For other SERDES read PRBS_ERR registers. | 0b0: No MAX9271/MAX9273-compatible PRBS test completed<br>0b1: MAX9271/MAX9273-compatible PRBS test completed normally |
| GPI_IN              | 4           | GPI pin level   | 0b0: GPI is input low<br>0b1: GPI is input high  |

| BITFIELD       | BITS | DESCRIPTION  | DECODE  |
|----------------|------|--|---|
| MAX_RT_ERR_GPI | 3    | Maximum retransmission error flag.<br>Cleared when read. | 0b0: No control-channel retransmission error<br>0b1: Control-channel retransmission maximum limit reached |

**GMSL1\_18 (0xB18)**

| BIT         | 7                | 6 | 5 | 4 | 3 | 2 | 1 | 0 |
|-------------|------------------|---|---|---|---|---|---|---|
| Field       | CC_RETR_CNT[7:0] |   |   |   |   |   |   |   |
| Reset       | 0x00             |   |   |   |   |   |   |   |
| Access Type | Read Only        |   |   |   |   |   |   |   |

| BITFIELD    | BITS | DESCRIPTION                              | DECODE   |
|-------------|------|--|--|
| CC_RETR_CNT | 7:0  | I <sup>2</sup> C packet retransmit count | 0xXX: Number of I <sup>2</sup> C packets retransmitted |

**GMSL1\_19 (0xB19)**

| BIT         | 7                  | 6 | 5 | 4 | 3 | 2 | 1 | 0 |
|-------------|--------------------|---|---|---|---|---|---|---|
| Field       | CC_CRC_ERRCNT[7:0] |   |   |   |   |   |   |   |
| Reset       | 0x00               |   |   |   |   |   |   |   |
| Access Type | Read Only          |   |   |   |   |   |   |   |

| BITFIELD      | BITS | DESCRIPTION                                    | DECODE                                     |
|---------------|------|--|--|
| CC_CRC_ERRCNT | 7:0  | Packet-based control-channel CRC error counter | 0xXX: Number of control-channel CRC errors |

**GMSL1\_1A (0xB1A)**

| BIT         | 7                 | 6 | 5 | 4 | 3 | 2 | 1 | 0 |
|-------------|-------------------|---|---|---|---|---|---|---|
| Field       | RCEG_ERR_CNT[7:0] |   |   |   |   |   |   |   |
| Reset       | 0x00              |   |   |   |   |   |   |   |
| Access Type | Read Only         |   |   |   |   |   |   |   |

| BITFIELD     | BITS | DESCRIPTION                                | DECODE   |
|--------------|------|--|--|
| RCEG_ERR_CNT | 7:0  | Control-channel number of generated errors | 0xXX: Number of control-channel generated errors |

**GMSL1\_1B (0xB1B)**

| BIT         | 7 | 6 | 5 | 4 | 3 | 2            | 1 | 0 |
|-------------|---|---|---|---|---|--------------|---|---|
| Field       | – | – | – | – | – | LINE_CRC_ERR | – | – |
| Reset       | – | – | – | – | – | 0b0          | – | – |
| Access Type | – | – | – | – | – | Read Only    | – | – |

| BITFIELD     | BITS | DESCRIPTION  | DECODE  |
|--------------|------|--|---|
| LINE_CRC_ERR | 2    | CRC error bit.<br>Latched on error - cleared to 0 when read. | 0b0: Video line CRC ok<br>0b1: Video line CRC mismatch detected |

**GMSL1\_1C (0xB1C)**

| BIT         | 7 | 6 | 5                  | 4 | 3 | 2 | 1 | 0 |
|-------------|---|---|--------------------|---|---|---|---|---|
| Field       | – | – | EOM_EYE_WIDTH[5:0] |   |   |   |   |   |
| Reset       | – | – | 0b000000           |   |   |   |   |   |
| Access Type | – | – | Read Only          |   |   |   |   |   |

| BITFIELD      | BITS | DESCRIPTION  | DECODE   |
|---------------|------|--|--|
| EOM_EYE_WIDTH | 5:0  | Measured Eye-opening<br>Opening width = $EOM\_EYE\_WIDTH / 63 * 100\%$ | 0b000000: Width is 0%<br>0b000001: Width is 1/63 x 100%<br>0b000010: Width is 2/63 x 100%<br>...<br>...<br>0b111111: Width is 63/63 x 100% |

**GMSL1\_1D (0xB1D)**

| BIT         | 7 | 6 | 5 | 4              | 3            | 2 | 1 | 0 |
|-------------|---|---|---|----------------|--------------|---|---|---|
| Field       | – | – | – | UNDERBOOST_DET | AEQ_BST[3:0] |   |   |   |
| Reset       | – | – | – | 0b0            | 0x0          |   |   |   |
| Access Type | – | – | – | Read Only      | Read Only    |   |   |   |

| BITFIELD       | BITS | DESCRIPTION  | DECODE   |
|----------------|------|--|--|
| UNDERBOOST_DET | 4    | Underboost detected  | 0b0: Normal Operation<br>0x1: Underboost (at maximum AEQ gain) detected  |
| AEQ_BST        | 3:0  | Adaptive equalizer boost value. Selected adaptive equalizer value; settings correspond to gain at 750MHz | 0b0000: 1.6dB manual EQ setting<br>0x0001: 2.1dB manual EQ setting<br>0x0010: 2.8dB manual EQ setting<br>0x0011: 3.5dB manual EQ setting<br>0x0100: 4.3dB manual EQ setting<br>0x0101: 5.2dB manual EQ setting<br>0x0110: 6.3dB manual EQ setting<br>0x0111: 7.3dB manual EQ setting<br>0x1000: 8.5dB manual EQ setting<br>0x1001: 9.7dB manual EQ setting<br>0x1010: 11dB manual EQ setting<br>0x1011: 12.2dB manual EQ setting<br>0x1100: Reserved<br>0x1101: Reserved<br>0x1110: Reserved<br>0x1111: Reserved |

**GMSL1\_20 (0xB20)**

| BIT         | 7                | 6 | 5 | 4 | 3 | 2 | 1 | 0 |
|-------------|------------------|---|---|---|---|---|---|---|
| Field       | CRC_VALUE_0[7:0] |   |   |   |   |   |   |   |
| Reset       | 0x00             |   |   |   |   |   |   |   |
| Access Type | Read Only        |   |   |   |   |   |   |   |

| BITFIELD    | BITS | DESCRIPTION                                  | DECODE                        |
|-------------|------|--|-------------------------------|
| CRC_VALUE_0 | 7:0  | Bits [7:0] of CRC output for the latest line | 0xXX: CRC[7:0] of latest line |

**GMSL1\_21 (0xB21)**

| BIT         | 7                | 6 | 5 | 4 | 3 | 2 | 1 | 0 |
|-------------|------------------|---|---|---|---|---|---|---|
| Field       | CRC_VALUE_1[7:0] |   |   |   |   |   |   |   |
| Reset       | 0x00             |   |   |   |   |   |   |   |
| Access Type | Read Only        |   |   |   |   |   |   |   |

| BITFIELD    | BITS | DESCRIPTION                                   | DECODE                         |
|-------------|------|---|--------------------------------|
| CRC_VALUE_1 | 7:0  | Bits [15:8] of CRC output for the latest line | 0xXX: CRC[15:8] of latest line |

**GMSL1\_22 (0xB22)**

| BIT | 7 | 6 | 5 | 4 | 3 | 2 | 1 | 0 |
|-----|---|---|---|---|---|---|---|---|
|-----|---|---|---|---|---|---|---|---|

|                    |                  |
|--------------------|------------------|
| <b>Field</b>       | CRC_VALUE_2[7:0] |
| <b>Reset</b>       | 0x00             |
| <b>Access Type</b> | Read Only        |

| BITFIELD    | BITS | DESCRIPTION                                    | DECODE                          |
|-------------|------|--|---------------------------------|
| CRC_VALUE_2 | 7:0  | Bits [23:16] of CRC output for the latest line | 0xXX: CRC[23:16] of latest line |

**GMSL1\_23 (0xB23)**

|                    |                  |          |          |          |          |          |          |          |
|--------------------|------------------|----------|----------|----------|----------|----------|----------|----------|
| <b>BIT</b>         | <b>7</b>         | <b>6</b> | <b>5</b> | <b>4</b> | <b>3</b> | <b>2</b> | <b>1</b> | <b>0</b> |
| <b>Field</b>       | CRC_VALUE_3[7:0] |          |          |          |          |          |          |          |
| <b>Reset</b>       | 0x00             |          |          |          |          |          |          |          |
| <b>Access Type</b> | Read Only        |          |          |          |          |          |          |          |

| BITFIELD    | BITS | DESCRIPTION                                    | DECODE                          |
|-------------|------|--|---------------------------------|
| CRC_VALUE_3 | 7:0  | Bits [31:24] of CRC output for the latest line | 0xXX: CRC[31:24] of latest line |

**GMSL1\_96 (0xB96)**

|                    |                          |          |          |          |          |             |               |              |
|--------------------|--------------------------|----------|----------|----------|----------|-------------|---------------|--------------|
| <b>BIT</b>         | <b>7</b>                 | <b>6</b> | <b>5</b> | <b>4</b> | <b>3</b> | <b>2</b>    | <b>1</b>      | <b>0</b>     |
| <b>Field</b>       | CONV_GMSL1_DATATYPE[4:0] |          |          |          |          | DIS_HIBW_E  | CONV_GMSL1_EN | DBL_ALIGN_TO |
| <b>Reset</b>       | 0b00000                  |          |          |          |          | 0b0         | 0b0           | 0b1          |
| <b>Access Type</b> | Write, Read              |          |          |          |          | Write, Read | Write, Read   | Write, Read  |

| BITFIELD            | BITS | DESCRIPTION   | DECODE   |
|---------------------|------|---|--|
| CONV_GMSL1_DATATYPE | 7:3  | Convert from GMSL1 color format mapping to GMSL2 CSI transmitter color format | 0x0: RGB888 OLDI<br>0x1: RGB565<br>0x2: RGB666<br>0x3: YUV 422 8-bit Mux mode (use yuv_8_10_mux_mode)<br>0x4: YUV 422 10-bit Mux mode (use yuv_8_10_mux_mode)<br>0x5: RAW8 single<br>0x6: RAW10 single<br>0x7: RAW12 single<br>0x8: RAW14<br>0x9: User-defined Generic 24-bit<br>0xA: User-defined YUV422 12-bit<br>0xB: User-defined Generic 8-bit<br>0xC<br>0xD<br>0xE |

| BITFIELD      | BITS | DESCRIPTION   | DECODE  |
|---------------|------|---|---|
|               |      |   | 0xF<br>0x10: RGB888 VESA<br>0x11<br>0x12<br>0x13: YUV 422 8-bit Normal mode<br>0x14: YUV 422 10-bit Normal mode<br>0x15: RAW8 double (use alt_mem_map8)<br>0x16: RAW10 double (use alt_mem_map10)<br>0x17: RAW12 double (use alt_mem_map12)<br>0x18<br>0x19<br>0x1A<br>0x1B<br>0x1C<br>0x1D<br>0x1E<br>0x1F |
| DIS_HIBW_E    | 2    | Disable disparity error detection in HIBW   |   |
| CONV_GMSL1_EN | 1    | Enable conversion from GMSL1 color format mapping to GMSL2 CSI transmitter                                  |   |
| DBL_ALIGN_TO  | 0    | HIBW DBL mode type<br>1 = DBL-DBL mode with no alignment ( <b>d</b> )<br>0 = DBL-Single mode with alignment |   |

**GMSL1\_CA (0xBCA)**

| BIT         | 7 | 6 | 5 | 4 | 3 | 2         | 1         | 0         |
|-------------|---|---|---|---|---|-----------|-----------|-----------|
| Field       | – | – | – | – | – | PHASELOCK | WBLOCK_G1 | DATAOK    |
| Reset       | – | – | – | – | – | 0b0       | 0b0       | 0b0       |
| Access Type | – | – | – | – | – | Read Only | Read Only | Read Only |

| BITFIELD  | BITS | DESCRIPTION                        |
|-----------|------|------------------------------------|
| PHASELOCK | 2    | CDR locked                         |
| WBLOCK_G1 | 1    | Word boundary detected             |
| DATAOK    | 0    | Data activity detected on the link |

**GMSL1\_CB (0xBCB)**

| BIT         | 7 | 6 | 5 | 4 | 3 | 2 | 1 | 0         |
|-------------|---|---|---|---|---|---|---|-----------|
| Field       | – | – | – | – | – | – | – | LOCKED_G1 |
| Reset       | – | – | – | – | – | – | – | 0b0       |
| Access Type | – | – | – | – | – | – | – | Read Only |

| BITFIELD  | BITS | DESCRIPTION |
|-----------|------|-------------|
| LOCKED_G1 | 0    | Link locked |

**GMSL1 D1 (0xBD1)**

| BIT         | 7                 | 6 | 5 | 4                | 3 | 2 | 1 | 0 |
|-------------|-------------------|---|---|------------------|---|---|---|---|
| Field       | CNTL_OUT_ORD[2:0] |   |   | CNTL_OUT_EN[4:0] |   |   |   |   |
| Reset       | 0b000             |   |   | 0b00000          |   |   |   |   |
| Access Type | Write, Read       |   |   | Write, Read      |   |   |   |   |

| BITFIELD     | BITS | DESCRIPTION                                    | DECODE   |
|--------------|------|--|--|
| CNTL_OUT_ORD | 7:5  | Internal CNTL_OUT order to pins CNTL4 to CNTL0 | 0x0: 4,3,2,1,0<br>0x1: 3,2,1,0,4<br>0x2: 2,1,0,4,3<br>0x3: 1,0,4,3,2<br>0x4: 0,1,2,3,4<br>0x5: 1,2,3,4,0<br>0x6: 2,3,4,0,1<br>0x7: 3,4,0,1,2 |
| CNTL_OUT_EN  | 4:0  | CNTL output enable for CNTL 0,1,2,3,4          |  |

**GMSL1 2 (0xC02)**

| BIT         | 7 | 6 | 5 | 4 | 3 | 2 | 1           | 0 |
|-------------|---|---|---|---|---|---|-------------|---|
| Field       | – | – | – | – | – | – | SRNG[1:0]   |   |
| Reset       | – | – | – | – | – | – | 0b11        |   |
| Access Type | – | – | – | – | – | – | Write, Read |   |

| BITFIELD | BITS | DESCRIPTION            | DECODE   |
|----------|------|------------------------|--|
| SRNG     | 1:0  | Serial data rate range | 0x0: 0.5 to 1Gbps<br>0x1: 1 to 1.5Gbps<br>0x2: 1.5 to 3.125Gbps<br>0x3: Autodetect |

**GMSL1 4 (0xC04)**

| BIT   | 7 | 6      | 5      | 4                | 3 | 2 | 1       | 0      |
|-------|---|--------|--------|------------------|---|---|---------|--------|
| Field | – | OUTENB | PRBSEN | CC_PORT_SEL[1:0] |   | – | REVCCEN | FWDCEN |
| Reset | – | 0b0    | 0b0    | 0b00             |   | – | 0b1     | 0b1    |

|                    |   |             |             |             |   |             |             |
|--------------------|---|-------------|-------------|-------------|---|-------------|-------------|
| <b>Access Type</b> | – | Write, Read | Write, Read | Write, Read | – | Write, Read | Write, Read |
|--------------------|---|-------------|-------------|-------------|---|-------------|-------------|

| BITFIELD    | BITS | DESCRIPTION   | DECODE  |
|-------------|------|---|---|
| OUTENB      | 6    | Disable outputs   | 0b0: Outputs enabled<br>0b1: Outputs disabled   |
| PRBSEN      | 5    | PRBS test enable (In HIBW mode set PRBS_TYPE=0)                   | 0b0: Set device normal operation<br>0b1: Enable PRBS test   |
| CC_PORT_SEL | 4:3  | Select which I <sup>2</sup> C/UART port is connected to this link | 0x0: CC port<br>0x1: Port 0 (RX0_SDA0, TX0_SCL0)<br>0x2: Port 1 (RX1_SDA1, TX1_SCL1)<br>0x3: Reserved |
| REVCCEN     | 1    | Enable reverse control channel from deserializer                  | 0b0: Disable reverse control channel receiver<br>0b1: Enable reverse control channel receiver         |
| FWDCEN      | 0    | Enable forward control channel to deserializer                    | 0b0: Disable forward control channel transmitter<br>0b1: Enable forward control channel transmitter   |

### GMSL1\_5 (0xC05)

| BIT                | 7           | 6           | 5           | 4           | 3           | 2 | 1 | 0 |
|--------------------|-------------|-------------|-------------|-------------|-------------|---|---|---|
| <b>Field</b>       | I2CMETHOD   | NO_REM_MST  | HVTR_MODE   | EN_EQ       | EQTUNE[3:0] |   |   |   |
| <b>Reset</b>       | 0b0         | 0b0         | 0b1         | 0b1         | 0x9         |   |   |   |
| <b>Access Type</b> | Write, Read | Write, Read | Write, Read | Write, Read | Write, Read |   |   |   |

| BITFIELD   | BITS | DESCRIPTION   | DECODE   |
|------------|------|---|--|
| I2CMETHOD  | 7    | I <sup>2</sup> C Method - Skip register address when converting UART-to-I <sup>2</sup> C  | 0b0: Send the register address during UART-to-I <sup>2</sup> C conversion<br>0b1: Do not send the register address during UART-to-I <sup>2</sup> C conversion  |
| NO_REM_MST | 6    | Set to 1 to indicate that there is no I <sup>2</sup> C main on remote side so this (local) chip should ignore any I <sup>2</sup> C packet initiation (start condition) from remote side |  |
| HVTR_MODE  | 5    | HV tracking allows continuous HSYNC format  | 0b0: Use partial periodic HV tracking<br>0b1: Use partial and full periodic HV tracking  |
| EN_EQ      | 4    | Enable equalizer for manual and adaptive modes  | 0b0: Disable equalization<br>0b1: Enable equalization  |
| EQTUNE     | 3:0  | Equalizer boost level at 750MHz (effective when Adaptive EQ is turned off)  | 0b0000: 1.6dB manual EQ setting<br>0x0001: 2.1dB manual EQ setting<br>0x0010: 2.8dB manual EQ setting<br>0x0011: 3.5dB manual EQ setting<br>0x0100: 4.3dB manual EQ setting<br>0x0101: 5.2dB manual EQ setting<br>0x0110: 6.3dB manual EQ setting<br>0x0111: 7.3dB manual EQ setting<br>0x1000: 8.5dB manual EQ setting<br>0x1001: 9.7dB manual EQ setting<br>0x1010: 11dB manual EQ setting |

| BITFIELD | BITS | DESCRIPTION | DECODE   |
|----------|------|-------------|--|
|          |      |             | 0x1011: 12.2dB manual EQ setting<br>0x1100: Reserved<br>0x1101: Reserved<br>0x1110: Reserved<br>0x1111: Reserved |

**GMSL1\_6 (0xC06)**

| BIT         | 7           | 6           | 5           | 4           | 3           | 2           | 1 | 0 |
|-------------|-------------|-------------|-------------|-------------|-------------|-------------|---|---|
| Field       | HIGHIMM     | MAX_RT_EN   | I2C_RT_EN   | GPI_COMP_EN | GPI_RT_EN   | HV_SRC[2:0] |   |   |
| Reset       | 0b0         | 0b1         | 0b1         | 0b0         | 0b1         | 0b111       |   |   |
| Access Type | Write, Read | Write, Read | Write, Read | Write, Read | Write, Read | Write, Read |   |   |

| BITFIELD    | BITS | DESCRIPTION                            | DECODE  |
|-------------|------|--|---|
| HIGHIMM     | 7    | Reverse channel high immunity mode     | 0b0: Reverse channel high immunity mode disabled<br>0b1: Reverse channel high immunity mode enabled   |
| MAX_RT_EN   | 6    | Maximum retransmission limit enable    | 0b0: Disable maximum retransmission limit<br>0b1: Enable maximum retransmission limit   |
| I2C_RT_EN   | 5    | I <sup>2</sup> C retransmission enable | 0b0: Disable I <sup>2</sup> C retransmission<br>0b1: Enable I <sup>2</sup> C retransmission enable  |
| GPI_COMP_EN | 4    | GPI skew compensation enable           | 0b0: Disable GPI skew compensation<br>0b1: Enable GPI skew compensation   |
| GPI_RT_EN   | 3    | GPI retransmission enable              | 0b0: Disable GPI retransmission<br>0b1: Enable GPI retransmission   |
| HV_SRC      | 2:0  | HV_VS bit selection                    | 0b000: Use D18/D19 for HS/VS (use this setting when the serializer is a 3.12Gbps device or if HIBW mode is used; otherwise, this setting is for use with the MAX9273 when DBL = 0 or HVEN = 1)<br>0b001: Use D14/D15 for HS/VS (for use with the MAX9271/MAX96705 when DBL = 0 or HVEN = 1)<br>0b010: Use D12/D13 for HS/VS (for use with the MAX96707 when DBL = 0 or HVEN = 1)<br>0b011: Use D0/D1 for HS/VS (for use with the MAX9271/MAX9273/MAX96705/MAX96707 when DBL = 1 and HVEN = 0)<br>0b100: Reserved<br>0b101: Reserved<br>0b110: Automatically determine the source of HSYNC/VSYN (for use with the MAX96707)<br>0b111: Automatically determine the source of HSYNC/VSYN (for use with the MAX96705) |

**GMSL1\_7 (0xC07)**

| BIT         | 7           | 6           | 5           | 4 | 3           | 2           | 1 | 0           |
|-------------|-------------|-------------|-------------|---|-------------|-------------|---|-------------|
| Field       | DBL         | DRS         | BWS         | – | HIBW        | HVEN        | – | PXL_CRC     |
| Reset       | 0b0         | 0b0         | 0b0         | – | 0b0         | 0b0         | – | 0b0         |
| Access Type | Write, Read | Write, Read | Write, Read | – | Write, Read | Write, Read | – | Write, Read |

| BITFIELD | BITS | DESCRIPTION   | DECODE  |
|----------|------|---|---|
| DBL      | 7    | Double-output mode  | 0b0: Use single-rate output<br>0b1: Use double-rate output (2x word rate at 1/2x width)   |
| DRS      | 6    | Data rate select  | 0b0: Use normal data rate output<br>0b1: Use 1/2 rate data output (for use with low data rates)                                       |
| BWS      | 5    | Bus width select  | 0b0: Set bus width for 22-/24-bit bus, 24-/27-bit mode (depending on HIBW setting)<br>0b1: Set bus width for 30-bit bus (32-bit mode) |
| HIBW     | 3    | High-bandwidth mode   | 0b0: Disable high-bandwidth mode<br>0b1: Enable high-bandwidth mode (when BWS = 0)  |
| HVEN     | 2    | HS/VS encoding enable   | 0b0: Disable HS/VS encoding<br>0b1: Enable HS/VS encoding   |
| PXL_CRC  | 0    | Pixel error detection type (this is controllable by pin when LCCEN=0) | 0b0: Use 1-bit parity (compatible with all devices)<br>0b1: Use 6-bit CRC   |

### GMSL1\_8 (0xC08)

| BIT         | 7            | 6 | 5           | 4           | 3 | 2           | 1                  | 0 |
|-------------|--------------|---|-------------|-------------|---|-------------|--------------------|---|
| Field       | GPI_SEL[1:0] |   | GPI_EN      | EN_FSYNC_TX | – | PKTCC_EN    | CC_CRC_LENGTH[1:0] |   |
| Reset       | 0b00         |   | 0b1         | 0b0         | – | 0b0         | 0b01               |   |
| Access Type | Write, Read  |   | Write, Read | Write, Read | – | Write, Read | Write, Read        |   |

| BITFIELD      | BITS | DESCRIPTION   | DECODE  |
|---------------|------|---|---|
| GPI_SEL       | 7:6  | Select GPI pin to transmit to Serializer            | 0x0: GPI_0<br>0x1: GPI_1<br>0x2: GPI_2<br>0x3: GPI_3  |
| GPI_EN        | 5    | Enable GPI-to-GPO signal transmission to serializer | 0b0: Disable GPI-to-GPO transmission<br>0b1: Enable GPI-to-GPO transmission                     |
| EN_FSYNC_TX   | 4    | Enable frame sync signal transmission               |   |
| PKTCC_EN      | 2    | Packet based control channel mode enable            | 0b0: Disable packet-based control-channel mode<br>0b1: Enable packet-based control-channel mode |
| CC_CRC_LENGTH | 1:0  | Control channel CRC length                          | 0b00: 1-bit CRC<br>0b01: 5-bit CRC<br>0b10: 8-bit CRC<br>0b11: Reserved                         |

### GMSL1\_D (0xC0D)

| BIT         | 7           | 6 | 5 | 4 | 3 | 2              | 1 | 0 |
|-------------|-------------|---|---|---|---|----------------|---|---|
| Field       | I2C_LOC_ACK | – | – | – | – | HS_TRACK_FSYNC | – | – |
| Reset       | 0b0         | – | – | – | – | 0b0            | – | – |
| Access Type | Write, Read | – | – | – | – | Write, Read    | – | – |

| BITFIELD       | BITS | DESCRIPTION   | DECODE  |
|----------------|------|---|---|
| I2C_LOC_ACK    | 7    | Enable I <sup>2</sup> C-to-I <sup>2</sup> C subordinate local acknowledge when forward channel is not available | 0b0: Disable local acknowledge when forward channel is not available<br>0b1: Enable local acknowledge when forward channel is not available |
| HS_TRACK_FSYNC | 2    | 0 = Allow infinite length vertical blanking<br>1 = Lose HLOCKED with VLOCKED                                    |   |

**GMSL1\_E (0xC0E)**

| BIT         | 7            | 6 | 5 | 4 | 3 | 2 | 1 | 0 |
|-------------|--------------|---|---|---|---|---|---|---|
| Field       | DET_THR[7:0] |   |   |   |   |   |   |   |
| Reset       | 0x00         |   |   |   |   |   |   |   |
| Access Type | Write, Read  |   |   |   |   |   |   |   |

| BITFIELD | BITS | DESCRIPTION                   | DECODE  |
|----------|------|-------------------------------|---|
| DET_THR  | 7:0  | Threshold for detected errors | 0xXX: Number of errors for detected error threshold |

**GMSL1\_F (0xC0F)**

| BIT         | 7 | 6           | 5           | 4           | 3           | 2 | 1 | 0           |
|-------------|---|-------------|-------------|-------------|-------------|---|---|-------------|
| Field       | – | EN_DE_FILT  | EN_HS_FILT  | EN_VS_FILT  | DE_EN       | – | – | PRBS_TYPE   |
| Reset       | – | 0b0         | 0b0         | 0b0         | 0b1         | – | – | 0b1         |
| Access Type | – | Write, Read | Write, Read | Write, Read | Write, Read | – | – | Write, Read |

| BITFIELD   | BITS | DESCRIPTION  | DECODE  |
|------------|------|--|---|
| EN_DE_FILT | 6    | Enable glitch filtering on DE  | 0b0: Disable DE glitch filtering<br>0b1: Enable DE glitch filtering                   |
| EN_HS_FILT | 5    | Enable glitch filtering on HS  | 0b0: Disable HS glitch filtering<br>0b1: Enable HS glitch filtering                   |
| EN_VS_FILT | 4    | Enable glitch filtering on VS  | 0b0: Disable VS glitch filtering<br>0b1: Enable VS glitch filtering                   |
| DE_EN      | 3    | Enable processing separate HS and DE signals   | 0b0: Disable processing HS and DE signals<br>0b1: Enable processing HS and DE signals |
| PRBS_TYPE  | 0    | PRBS type select (in HIBW mode set PRBS_TYPE = 0) PRBS_TYPE setting must match in serializer and deserializer. | 0b0: GMSL1 Legacy style PRBS test<br>0b1: Non-GMSL1 Legacy style PRBS test            |

**GMSL1 10 (0xC10)**

| BIT         | 7              | 6 | 5           | 4                 | 3 | 2 | 1           | 0 |
|-------------|----------------|---|-------------|-------------------|---|---|-------------|---|
| Field       | RCEG_TYPE[1:0] |   | RCEG_BOUND  | RCEG_ERR_NUM[3:0] |   |   | RCEG_EN     |   |
| Reset       | 0b00           |   | 0b0         | 0x1               |   |   | 0b0         |   |
| Access Type | Write, Read    |   | Write, Read | Write, Read       |   |   | Write, Read |   |

| BITFIELD     | BITS | DESCRIPTION   | DECODE  |
|--------------|------|---|---|
| RCEG_TYPE    | 7:6  | Reverse channel generated error type  | 0b00: Random<br>0b01: Short burst<br>0b10: Long burst<br>0b11: Long burst                           |
| RCEG_BOUND   | 5    | Reverse channel generated error boundary (Effective when RCEG_TYPE = 0x)          | 0b0: Errors are unbounded to symbols<br>0b1: Errors are bounded to symbols                          |
| RCEG_ERR_NUM | 4:1  | Number of RCEG errors generated with each request (Effective when RCEG_TYPE = 0x) | 0xX: Number of errors generated per request   |
| RCEG_EN      | 0    | Enable reverse channel error generator  | 0b0: Disable reverse channel error generator<br>0b1: Enable reverse channel error generator enabled |

**GMSL1 11 (0xC11)**

| BIT         | 7                  | 6 | 5 | 4 | 3                    | 2 | 1                    | 0 |
|-------------|--------------------|---|---|---|----------------------|---|----------------------|---|
| Field       | RCEG_ERR_RATE[3:0] |   |   |   | RCEG_LO_BST_PRB[1:0] |   | RCEG_LO_BST_LEN[1:0] |   |
| Reset       | 0xF                |   |   |   | 0b00                 |   | 0b00                 |   |
| Access Type | Write, Read        |   |   |   | Write, Read          |   | Write, Read          |   |

| BITFIELD        | BITS | DESCRIPTION   | DECODE   |
|-----------------|------|---|--|
| RCEG_ERR_RATE   | 7:4  | Error generation rate in terms of bit time = $2^{-(RCEG\_ERR\_RATE+3)}$ , (Effective when RCEG_TYPE = 0x) | 0x0: Rate is 2 <sup>-3</sup><br>0x1: Rate is 2 <sup>-4</sup><br>0x2: Rate is 2 <sup>-5</sup><br>...<br>0xF: Rate is 2 <sup>-18</sup> |
| RCEG_LO_BST_PRB | 3:2  | Long burst error probability. Effective when RCEG_TYPE = 10.  | 0b00: 1/1024<br>0b01: 1/128<br>0b10: 1/32<br>0b11: 1/8   |
| RCEG_LO_BST_LEN | 1:0  | Long burst error length in terms of bit time. Effective when RCEG_TYPE = 10.                              | 0b00: Continuous<br>0b01: 128 (~150µs)<br>0b10: 8192 (~9.83ms)<br>0b11: 1048576 (~1.26s)   |

**GMSL1 12 (0xC12)**

| BIT         | 7 | 6             | 5                 | 4 | 3                 | 2 | 1             | 0               |
|-------------|---|---------------|-------------------|---|-------------------|---|---------------|-----------------|
| Field       | – | CC_CRC_ERR_EN | LINE_CRC_LOC[1:0] |   | LINE_CRC_EN_GMSL1 | – | MAX_RT_ERR_EN | RCEG_ERR_PER_EN |
| Reset       | – | 0b1           | 0b01              |   | 0b0               | – | 0b1           | 0b0             |
| Access Type | – | Write, Read   | Write, Read       |   | Write, Read       | – | Write, Read   | Write, Read     |

| BITFIELD          | BITS | DESCRIPTION   | DECODE  |
|-------------------|------|---|---|
| CC_CRC_ERR_EN     | 6    | Enable reporting of (CC_CRC_ERR_CNT > 0) on the ERRORB pin          | 0b0: Disable reporting of errors on ERRORB<br>0b1: Enable reporting of errors on ERRORB                                 |
| LINE_CRC_LOC      | 5:4  | Video line CRC insertion location                                   | 0b00: [1..4]<br>0x01: [5..8]<br>0x10: [9..12]<br>0x11: [13..16]   |
| LINE_CRC_EN_GMSL1 | 3    | Video line CRC enable   | 0b0: Disable video line CRC<br>0x1: Enable video line CRC   |
| MAX_RT_ERR_EN     | 1    | Enable reflection of maximum retransmission error on the ERRORB pin | 0b0: Disable maximum retransmission error on the ERROR pin<br>0b1: Enable maximum retransmission error on the ERROR pin |
| RCEG_ERR_PER_EN   | 0    | Periodic error generation enable. Effective when RCEG_TYPE = 0x.    | 0b0: Disable periodic error generator<br>0b1: Enable periodic error generator   |

**GMSL1 13 (0xC13)**

| BIT         | 7           | 6               | 5                  | 4                   | 3 | 2 | 1 | 0 |
|-------------|-------------|-----------------|--------------------|---------------------|---|---|---|---|
| Field       | EOM_EN_G1   | EOM_PER_MODE_G1 | EOM_MAN_TRG_REQ_G1 | EOM_MIN_THR_G1[4:0] |   |   |   |   |
| Reset       | 0b1         | 0b1             | 0b0                | 0b00000             |   |   |   |   |
| Access Type | Write, Read | Write, Read     | Write, Read        | Write, Read         |   |   |   |   |

| BITFIELD           | BITS | DESCRIPTION   | DECODE  |
|--------------------|------|---|---|
| EOM_EN_G1          | 7    | Eye-opening monitor enable  | 0b0: Disable EOM<br>0x1: Enable EOM                                       |
| EOM_PER_MODE_G1    | 6    | Eye-opening monitor periodic mode select  | 0b0: Set EOM to use nonperiodic mode<br>0x1: Set EOM to use periodic mode |
| EOM_MAN_TRG_REQ_G1 | 5    | Eye-opening monitor (EOM) manual trigger request. Valid on the rising edge of this bit when not in periodic mode. | 0x0: Do not trigger EOM<br>0x1: Manually trigger the EOM                  |

| BITFIELD       | BITS | DESCRIPTION   | DECODE   |
|----------------|------|---|--|
| EOM_MIN_THR_G1 | 4:0  | Eye-opening minimum threshold (in terms of percent) for flagging ERRORB pin | 0b00000: Disabled<br>0b00001: 3.125%<br>0b00010: 6.25%<br>...<br>0b11111: 100% |

**GMSL1 14 (0xC14)**

| BIT         | 7           | 6            | 5               | 4                | 3 | 2 | 1 | 0 |
|-------------|-------------|--------------|-----------------|------------------|---|---|---|---|
| Field       | AEQ_EN      | AEQ_PER_MODE | AEQ_MAN_TRG_REQ | EOM_PER_THR[4:0] |   |   |   |   |
| Reset       | 0b1         | 0b0          | 0b0             | 0b00000          |   |   |   |   |
| Access Type | Write, Read | Write, Read  | Write, Read     | Write, Read      |   |   |   |   |

| BITFIELD        | BITS | DESCRIPTION   | DECODE   |
|-----------------|------|---|--|
| AEQ_EN          | 7    | Adaptive equalization enable  | 0b0: Disable AEQ<br>0x1: Enable AEQ  |
| AEQ_PER_MODE    | 6    | Adaptive equalizer periodic mode select   | 0b0: Set AEQ to use nonperiodic mode<br>0x1: Set AEQ to use periodic mode  |
| AEQ_MAN_TRG_REQ | 5    | Adaptive equalizer manual fine-tune request enable. Valid on the rising edge of this bit when not in periodic mode. | 0x0: Do not trigger AEQ fine-tuning<br>0x1: Manually trigger the AEQ fine-tuning                                       |
| EOM_PER_THR     | 4:0  | Eye-opening threshold to trigger a fine-tune operation  | 0b00000: Eye-opening threshold is disabled<br>0b10000: 50% eye-opening triggers fine-tune operation<br>OTHER: Reserved |

**GMSL1 15 (0xC15)**

| BIT         | 7            | 6 | 5 | 4 | 3 | 2 | 1 | 0 |
|-------------|--------------|---|---|---|---|---|---|---|
| Field       | DET_ERR[7:0] |   |   |   |   |   |   |   |
| Reset       | 0x00         |   |   |   |   |   |   |   |
| Access Type | Read Only    |   |   |   |   |   |   |   |

| BITFIELD | BITS | DESCRIPTION            | DECODE                          |
|----------|------|------------------------|---------------------------------|
| DET_ERR  | 7:0  | Detected error counter | 0xXX: Number of detected errors |

**GMSL1 16 (0xC16)**

| BIT | 7 | 6 | 5 | 4 | 3 | 2 | 1 | 0 |
|-----|---|---|---|---|---|---|---|---|
|-----|---|---|---|---|---|---|---|---|

|                    |               |
|--------------------|---------------|
| <b>Field</b>       | PRBS_ERR[7:0] |
| <b>Reset</b>       | 0x00          |
| <b>Access Type</b> | Read Only     |

| BITFIELD | BITS | DESCRIPTION        | DECODE                               |
|----------|------|--------------------|--------------------------------------|
| PRBS_ERR | 7:0  | PRBS error counter | 0xXX: Number of detected PRBS errors |

**GMSL1\_17 (0xC17)**

| BIT                | 7                   | 6              | 5         | 4         | 3              | 2 | 1 | 0 |
|--------------------|---------------------|----------------|-----------|-----------|----------------|---|---|---|
| <b>Field</b>       | I2C_TIMED_OUT_GMSL1 | MAX_RT_ERR_I2C | PRBS_OK   | GPI_IN    | MAX_RT_ERR_GPI | – | – | – |
| <b>Reset</b>       | 0b0                 | 0b0            | 0b0       | 0b0       | 0b0            | – | – | – |
| <b>Access Type</b> | Read Only           | Read Only      | Read Only | Read Only | Read Only      | – | – | – |

| BITFIELD            | BITS | DESCRIPTION   | DECODE   |
|---------------------|------|---|--|
| I2C_TIMED_OUT_GMSL1 | 7    | I <sup>2</sup> C channel timed out flag   | 0b0: I <sup>2</sup> C channel not timed out<br>0b1: I <sup>2</sup> C channel timed out                                 |
| MAX_RT_ERR_I2C      | 6    | Maximum retransmission error flag.<br>Cleared when read.  | 0b0: No control-channel retransmission error<br>0b1: Control-channel retransmission maximum limit reached              |
| PRBS_OK             | 5    | MAX9271/73 compatible PRBS test for link is completed normally. Check PRBS_ERR register for the PRBS success. For other SERDES read PRBS_ERR registers. | 0b0: No MAX9271/MAX9273-compatible PRBS test completed<br>0b1: MAX9271/MAX9273-compatible PRBS test completed normally |
| GPI_IN              | 4    | GPI pin level   | 0b0: GPI is input low<br>0b1: GPI is input high  |
| MAX_RT_ERR_GPI      | 3    | Maximum retransmission error flag.<br>Cleared when read.  | 0b0: No control-channel retransmission error<br>0b1: Control-channel retransmission maximum limit reached              |

**GMSL1\_18 (0xC18)**

| BIT                | 7                | 6 | 5 | 4 | 3 | 2 | 1 | 0 |
|--------------------|------------------|---|---|---|---|---|---|---|
| <b>Field</b>       | CC_RETR_CNT[7:0] |   |   |   |   |   |   |   |
| <b>Reset</b>       | 0x00             |   |   |   |   |   |   |   |
| <b>Access Type</b> | Read Only        |   |   |   |   |   |   |   |

| BITFIELD    | BITS | DESCRIPTION                              | DECODE   |
|-------------|------|--|--|
| CC_RETR_CNT | 7:0  | I <sup>2</sup> C packet retransmit count | 0xXX: Number of I <sup>2</sup> C packets retransmitted |

**GMSL1 19 (0xC19)**

| BIT         | 7                  | 6 | 5 | 4 | 3 | 2 | 1 | 0 |
|-------------|--------------------|---|---|---|---|---|---|---|
| Field       | CC_CRC_ERRCNT[7:0] |   |   |   |   |   |   |   |
| Reset       | 0x00               |   |   |   |   |   |   |   |
| Access Type | Read Only          |   |   |   |   |   |   |   |

| BITFIELD      | BITS | DESCRIPTION                                    | DECODE                                     |
|---------------|------|--|--|
| CC_CRC_ERRCNT | 7:0  | Packet based control channel CRC error counter | 0xXX: Number of control channel CRC errors |

**GMSL1 1A (0xC1A)**

| BIT         | 7                 | 6 | 5 | 4 | 3 | 2 | 1 | 0 |
|-------------|-------------------|---|---|---|---|---|---|---|
| Field       | RCEG_ERR_CNT[7:0] |   |   |   |   |   |   |   |
| Reset       | 0x00              |   |   |   |   |   |   |   |
| Access Type | Read Only         |   |   |   |   |   |   |   |

| BITFIELD     | BITS | DESCRIPTION                                | DECODE   |
|--------------|------|--|--|
| RCEG_ERR_CNT | 7:0  | Control channel number of generated errors | 0xXX: Number of control channel generated errors |

**GMSL1 1B (0xC1B)**

| BIT         | 7 | 6 | 5 | 4 | 3 | 2            | 1 | 0 |
|-------------|---|---|---|---|---|--------------|---|---|
| Field       | - | - | - | - | - | LINE_CRC_ERR | - | - |
| Reset       | - | - | - | - | - | 0b0          | - | - |
| Access Type | - | - | - | - | - | Read Only    | - | - |

| BITFIELD     | BITS | DESCRIPTION   | DECODE  |
|--------------|------|---|---|
| LINE_CRC_ERR | 2    | CRC error bit. Latched on error - cleared to 0 when read. | 0b0: Video line CRC ok<br>0b1: Video line CRC mismatch detected |

**GMSL1\_1C (0xC1C)**

| BIT         | 7 | 6 | 5                  | 4 | 3 | 2 | 1 | 0 |
|-------------|---|---|--------------------|---|---|---|---|---|
| Field       | – | – | EOM_EYE_WIDTH[5:0] |   |   |   |   |   |
| Reset       | – | – | 0b000000           |   |   |   |   |   |
| Access Type | – | – | Read Only          |   |   |   |   |   |

| BITFIELD      | BITS | DESCRIPTION   | DECODE   |
|---------------|------|---|--|
| EOM_EYE_WIDTH | 5:0  | Measured Eye Opening<br>Opening width = EOM_EYE_WIDTH / 63 * 100% | 0b000000: Width is 0%<br>0b000001: Width is 1/63 x 100%<br>0b000010: Width is 2/63 x 100%<br>...<br>...<br>0b111111: Width is 63/63 x 100% |

**GMSL1\_1D (0xC1D)**

| BIT         | 7 | 6 | 5 | 4              | 3            | 2 | 1 | 0 |
|-------------|---|---|---|----------------|--------------|---|---|---|
| Field       | – | – | – | UNDERBOOST_DET | AEQ_BST[3:0] |   |   |   |
| Reset       | – | – | – | 0b0            | 0x0          |   |   |   |
| Access Type | – | – | – | Read Only      | Read Only    |   |   |   |

| BITFIELD       | BITS | DESCRIPTION  | DECODE   |
|----------------|------|--|--|
| UNDERBOOST_DET | 4    | Underboost detected  | 0b0: Normal Operation<br>0x1: Underboost (at maximum AEQ gain) detected  |
| AEQ_BST        | 3:0  | Adaptive equalizer boost value. Selected adaptive equalizer value; settings correspond to gain at 750MHz | 0b0000: 1.6dB manual EQ setting<br>0x0001: 2.1dB manual EQ setting<br>0x0010: 2.8dB manual EQ setting<br>0x0011: 3.5dB manual EQ setting<br>0x0100: 4.3dB manual EQ setting<br>0x0101: 5.2dB manual EQ setting<br>0x0110: 6.3dB manual EQ setting<br>0x0111: 7.3dB manual EQ setting<br>0x1000: 8.5dB manual EQ setting<br>0x1001: 9.7dB manual EQ setting<br>0x1010: 11dB manual EQ setting<br>0x1011: 12.2dB manual EQ setting<br>0x1100: Reserved<br>0x1101: Reserved<br>0x1110: Reserved<br>0x1111: Reserved |

**GMSL1 20 (0xC20)**

|                    |                  |          |          |          |          |          |          |          |
|--------------------|------------------|----------|----------|----------|----------|----------|----------|----------|
| <b>BIT</b>         | <b>7</b>         | <b>6</b> | <b>5</b> | <b>4</b> | <b>3</b> | <b>2</b> | <b>1</b> | <b>0</b> |
| <b>Field</b>       | CRC_VALUE_0[7:0] |          |          |          |          |          |          |          |
| <b>Reset</b>       | 0x00             |          |          |          |          |          |          |          |
| <b>Access Type</b> | Read Only        |          |          |          |          |          |          |          |

| <b>BITFIELD</b> | <b>BITS</b> | <b>DESCRIPTION</b>                           | <b>DECODE</b>                 |
|-----------------|-------------|--|-------------------------------|
| CRC_VALUE_0     | 7:0         | Bits [7:0] of CRC output for the latest line | 0xXX: CRC[7:0] of latest line |

**GMSL1 21 (0xC21)**

|                    |                  |          |          |          |          |          |          |          |
|--------------------|------------------|----------|----------|----------|----------|----------|----------|----------|
| <b>BIT</b>         | <b>7</b>         | <b>6</b> | <b>5</b> | <b>4</b> | <b>3</b> | <b>2</b> | <b>1</b> | <b>0</b> |
| <b>Field</b>       | CRC_VALUE_1[7:0] |          |          |          |          |          |          |          |
| <b>Reset</b>       | 0x00             |          |          |          |          |          |          |          |
| <b>Access Type</b> | Read Only        |          |          |          |          |          |          |          |

| <b>BITFIELD</b> | <b>BITS</b> | <b>DESCRIPTION</b>                            | <b>DECODE</b>                  |
|-----------------|-------------|---|--------------------------------|
| CRC_VALUE_1     | 7:0         | Bits [15:8] of CRC output for the latest line | 0xXX: CRC[15:8] of latest line |

**GMSL1 22 (0xC22)**

|                    |                  |          |          |          |          |          |          |          |
|--------------------|------------------|----------|----------|----------|----------|----------|----------|----------|
| <b>BIT</b>         | <b>7</b>         | <b>6</b> | <b>5</b> | <b>4</b> | <b>3</b> | <b>2</b> | <b>1</b> | <b>0</b> |
| <b>Field</b>       | CRC_VALUE_2[7:0] |          |          |          |          |          |          |          |
| <b>Reset</b>       | 0x00             |          |          |          |          |          |          |          |
| <b>Access Type</b> | Read Only        |          |          |          |          |          |          |          |

| <b>BITFIELD</b> | <b>BITS</b> | <b>DESCRIPTION</b>                             | <b>DECODE</b>                   |
|-----------------|-------------|--|---------------------------------|
| CRC_VALUE_2     | 7:0         | Bits [23:16] of CRC output for the latest line | 0xXX: CRC[23:16] of latest line |

**GMSL1 23 (0xC23)**

|              |                  |          |          |          |          |          |          |          |
|--------------|------------------|----------|----------|----------|----------|----------|----------|----------|
| <b>BIT</b>   | <b>7</b>         | <b>6</b> | <b>5</b> | <b>4</b> | <b>3</b> | <b>2</b> | <b>1</b> | <b>0</b> |
| <b>Field</b> | CRC_VALUE_3[7:0] |          |          |          |          |          |          |          |

|                    |           |
|--------------------|-----------|
| <b>Reset</b>       | 0x00      |
| <b>Access Type</b> | Read Only |

| BITFIELD    | BITS | DESCRIPTION                                    | DECODE                          |
|-------------|------|--|---------------------------------|
| CRC_VALUE_3 | 7:0  | Bits [31:24] of CRC output for the latest line | 0xXX: CRC[31:24] of latest line |

**GMSL1\_96 (0xC96)**

| BIT                | 7                        | 6 | 5 | 4 | 3 | 2           | 1             | 0            |
|--------------------|--------------------------|---|---|---|---|-------------|---------------|--------------|
| <b>Field</b>       | CONV_GMSL1_DATATYPE[4:0] |   |   |   |   | DIS_HIBW_E  | CONV_GMSL1_EN | DBL_ALIGN_TO |
| <b>Reset</b>       | 0b00000                  |   |   |   |   | 0b0         | 0b0           | 0b1          |
| <b>Access Type</b> | Write, Read              |   |   |   |   | Write, Read | Write, Read   | Write, Read  |

| BITFIELD            | BITS | DESCRIPTION   | DECODE  |
|---------------------|------|---|---|
| CONV_GMSL1_DATATYPE | 7:3  | Convert from GMSL1 color format mapping to GMSL2 CSI transmitter color format | 0x0: RGB888 OLDI<br>0x1: RGB565<br>0x2: RGB666<br>0x3: YUV 422 8-bit Mux mode (use yuv_8_10_mux_mode)<br>0x4: YUV 422 10-bit Mux mode (use yuv_8_10_mux_mode)<br>0x5: RAW8 single<br>0x6: RAW10 single<br>0x7: RAW12 single<br>0x8: RAW14<br>0x9: User-defined Generic 24-bit<br>0xA: User-defined YUV422 12-bit<br>0xB: User-defined Generic 8-bit<br>0xC<br>0xD<br>0xE<br>0xF<br>0x10: RGB888 VESA<br>0x11<br>0x12<br>0x13: YUV 422 8-bit Normal mode<br>0x14: YUV 422 10-bit Normal mode<br>0x15: RAW8 double (use alt_mem_map8)<br>0x16: RAW10 double (use alt_mem_map10)<br>0x17: RAW12 double (use alt_mem_map12)<br>0x18<br>0x19<br>0x1A<br>0x1B<br>0x1C<br>0x1D<br>0x1E<br>0x1F |
| DIS_HIBW_E          | 2    | Disable disparity error detection in HIBW                                     |   |
| CONV_GMSL1_EN       | 1    | Enable conversion from GMSL1 color format mapping to GMSL2 CSI transmitter    |   |

| BITFIELD     | BITS | DESCRIPTION   | DECODE |
|--------------|------|---|--------|
| DBL_ALIGN_TO | 0    | HIBW DBL mode type<br>1 = DBL-DBL mode with no alignment ( <b>d</b> )<br>0 = DBL-Single mode with alignment |        |

**GMSL1\_CA (0xCCA)**

| BIT         | 7 | 6 | 5 | 4 | 3 | 2         | 1         | 0         |
|-------------|---|---|---|---|---|-----------|-----------|-----------|
| Field       | – | – | – | – | – | PHASELOCK | WBLOCK_G1 | DATAOK    |
| Reset       | – | – | – | – | – | 0b0       | 0b0       | 0b0       |
| Access Type | – | – | – | – | – | Read Only | Read Only | Read Only |

| BITFIELD  | BITS | DESCRIPTION                        |
|-----------|------|------------------------------------|
| PHASELOCK | 2    | CDR locked                         |
| WBLOCK_G1 | 1    | Word boundary detected             |
| DATAOK    | 0    | Data activity detected on the link |

**GMSL1\_CB (0xCCB)**

| BIT         | 7 | 6 | 5 | 4 | 3 | 2 | 1 | 0         |
|-------------|---|---|---|---|---|---|---|-----------|
| Field       | – | – | – | – | – | – | – | LOCKED_G1 |
| Reset       | – | – | – | – | – | – | – | 0b0       |
| Access Type | – | – | – | – | – | – | – | Read Only |

| BITFIELD  | BITS | DESCRIPTION |
|-----------|------|-------------|
| LOCKED_G1 | 0    | Link locked |

**GMSL1\_D1 (0xCD1)**

| BIT         | 7                 | 6 | 5 | 4                | 3 | 2 | 1 | 0 |
|-------------|-------------------|---|---|------------------|---|---|---|---|
| Field       | CNTL_OUT_ORD[2:0] |   |   | CNTL_OUT_EN[4:0] |   |   |   |   |
| Reset       | 0b000             |   |   | 0b00000          |   |   |   |   |
| Access Type | Write, Read       |   |   | Write, Read      |   |   |   |   |

| BITFIELD     | BITS | DESCRIPTION                                    | DECODE   |
|--------------|------|--|--|
| CNTL_OUT_ORD | 7:5  | Internal CNTL_OUT order to pins CNTL4 to CNTL0 | 0x0: 4,3,2,1,0<br>0x1: 3,2,1,0,4<br>0x2: 2,1,0,4,3<br>0x3: 1,0,4,3,2<br>0x4: 0,1,2,3,4<br>0x5: 1,2,3,4,0<br>0x6: 2,3,4,0,1<br>0x7: 3,4,0,1,2 |
| CNTL_OUT_EN  | 4:0  | CNTL output enable for CNTL 0,1,2,3,4          |  |

**GMSL1\_EN (0xF00)**

| BIT         | 7 | 6 | 5 | 4 | 3 | 2 | 1           | 0           |
|-------------|---|---|---|---|---|---|-------------|-------------|
| Field       | - | - | - | - | - | - | LINK_EN_B   | LINK_EN_A   |
| Reset       | - | - | - | - | - | - | 0b1         | 0b1         |
| Access Type | - | - | - | - | - | - | Write, Read | Write, Read |

| BITFIELD  | BITS | DESCRIPTION   | DECODE                                    |
|-----------|------|---------------|---|
| LINK_EN_B | 1    | Enable link B | 0x0: Disable Link B<br>0x1: Enable Link B |
| LINK_EN_A | 0    | Enable link A | 0x0: Disable Link A<br>0x1: Enable Link A |

**GMSL1\_UART (0xF01)**

| BIT         | 7 | 6 | 5 | 4 | 3 | 2 | 1                 | 0                 |
|-------------|---|---|---|---|---|---|-------------------|-------------------|
| Field       | - | - | - | - | - | - | GMSL1_UART_ARB_TO | GMSL1_UART_ARB_EN |
| Reset       | - | - | - | - | - | - | 0b0               | 0b0               |
| Access Type | - | - | - | - | - | - | Write, Read       | Write, Read       |

| BITFIELD          | BITS | DESCRIPTION   | DECODE                      |
|-------------------|------|---|-----------------------------|
| GMSL1_UART_ARB_TO | 1    | GMSL1 UART arbitration time-out value                           | 0x0: 256us<br>0x1: 4ms      |
| GMSL1_UART_ARB_EN | 0    | UART arbitration enable on GMSL1 forward control channel links. | 0x0: Disable<br>0x1: Enable |

**COMMON1 (0xF02)**

| BIT | 7 | 6 | 5 | 4 | 3 | 2 | 1 | 0 |
|-----|---|---|---|---|---|---|---|---|
|-----|---|---|---|---|---|---|---|---|

|             |   |   |   |   |   |   |                    |                    |
|-------------|---|---|---|---|---|---|--------------------|--------------------|
| Field       | – | – | – | – | – | – | REM_ACK_ACKED_G1_B | REM_ACK_ACKED_G1_A |
| Reset       | – | – | – | – | – | – | 0b0                | 0b0                |
| Access Type | – | – | – | – | – | – | Read Only          | Read Only          |

| BITFIELD           | BITS | DESCRIPTION             | DECODE   |
|--------------------|------|-------------------------|--|
| REM_ACK_ACKED_G1_B | 1    | Remote ACK acknowledged | 0b0: Remote ACK not acknowledged<br>0b1: Remote ACK acknowledged |
| REM_ACK_ACKED_G1_A | 0    | Remote ACK acknowledged | 0b0: Remote ACK not acknowledged<br>0b1: Remote ACK acknowledged |

### GMSL1\_ERR\_OEN (0xF03)

|             |   |   |   |   |   |   |              |              |
|-------------|---|---|---|---|---|---|--------------|--------------|
| BIT         | 7 | 6 | 5 | 4 | 3 | 2 | 1            | 0            |
| Field       | – | – | – | – | – | – | G1_B_ERR_OEN | G1_A_ERR_OEN |
| Reset       | – | – | – | – | – | – | 0b1          | 0b1          |
| Access Type | – | – | – | – | – | – | Write, Read  | Write, Read  |

| BITFIELD     | BITS | DESCRIPTION  |
|--------------|------|--|
| G1_B_ERR_OEN | 1    | Enable reporting of GMSL1 Link B errors (G1_B_ERR_FLAG) at ERB pin |
| G1_A_ERR_OEN | 0    | Enable reporting of GMSL1 Link A errors (G1_A_ERR_FLAG) at ERB pin |

### GMSL1\_ERR\_FLAG (0xF04)

|             |   |   |   |   |   |   |               |               |
|-------------|---|---|---|---|---|---|---------------|---------------|
| BIT         | 7 | 6 | 5 | 4 | 3 | 2 | 1             | 0             |
| Field       | – | – | – | – | – | – | G1_B_ERR_FLAG | G1_A_ERR_FLAG |
| Reset       | – | – | – | – | – | – | 0b0           | 0b0           |
| Access Type | – | – | – | – | – | – | Read Only     | Read Only     |

| BITFIELD      | BITS | DESCRIPTION  |
|---------------|------|--|
| G1_B_ERR_FLAG | 1    | GMSL1 Link B error flag. When PRBS test is enabled, it is asserted when at least one PRBS error has been detected. When PRBS test is not enabled, it is asserted when any of these conditions is true:<br>1) Number of detected decoding errors are greater than the detected error threshold (DET_ERR > DET_THR)<br>2) Measured eye-opening is less than or equal to eye-opening threshold (EOM_EYE_WIDTH ≤ EOM_MIN_THR_G1) |

| BITFIELD      | BITS | DESCRIPTION   |
|---------------|------|---|
|               |      | 3) Adaptive EQ has detected underboost<br>4) Video Line CRC error is detected<br>5) Exceeded maximum retransmission count in PKTCC communication<br>6) CRC errors detected in PKTCC communication   |
| G1_A_ERR_FLAG | 0    | GMSL1 Link A error flag. When PRBS test is enabled, it is asserted when at least one PRBS error has been detected. When PRBS test is not enabled, it is asserted when any of these conditions is true:<br>1) Number of detected decoding errors are greater than the detected error threshold (DET_ERR > DET_THR)<br>2) Measured eye-opening is less than or equal to eye-opening threshold (EOM_EYE_WIDTH ≤ EOM_MIN_THR_G1)<br>3) Adaptive EQ has detected underboost<br>4) Video Line CRC error is detected<br>5) Exceeded maximum retransmission count in PKTCC communication<br>6) CRC errors detected in PKTCC communication |

**I2C 0 (0xF05)**

| BIT         | 7 | 6 | 5              | 4 | 3 | 2              | 1 | 0 |
|-------------|---|---|----------------|---|---|----------------|---|---|
| Field       | – | – | G1_SLV_SH[1:0] |   | – | G1_SLV_TO[2:0] |   |   |
| Reset       | – | – | 0b10           |   | – | 0b110          |   |   |
| Access Type | – | – | Write, Read    |   | – | Write, Read    |   |   |

| BITFIELD  | BITS | DESCRIPTION   | DECODE  |
|-----------|------|---|---|
| G1_SLV_SH | 5:4  | GMSL1 I <sup>2</sup> C-to-I <sup>2</sup> C subordinate setup and hold time setting (setup, hold). Configures the interval between SDA and SCL transitions when driven by the internal I <sup>2</sup> C subordinate.<br>Set this according to the I <sup>2</sup> C speed mode:<br>Fast-mode Plus = 00<br>Fast-mode = 01<br>Standard-mode = 10<br><br>Please see register groups CC_G2P* for GMSL2 registers. | 0b00: Set for I <sup>2</sup> C Fast-mode Plus speed (1Mbps)<br>0b01: Set for I <sup>2</sup> C Fast-mode speed (400Kbps)<br>0b10: Set for I <sup>2</sup> C standard-mode speed (100Kbps)<br>0b11: Reserved |
| G1_SLV_TO | 2:0  | GMSL1 I <sup>2</sup> C-to-I <sup>2</sup> C subordinate timeout setting<br>Internal GMSL1 I <sup>2</sup> C subordinate times out after the configured duration if it does not receive any response while waiting for a packet from remote device.<br><br>Please see register groups CC_G2P* for GMSL2 registers. (Addr. 0x500 - 0x6B0)   | 0b000: 16μs<br>0b001: 1ms<br>0b010: 2ms<br>0b011: 4ms<br>0b100: 8ms<br>0b101: 16ms<br>0b110: 32ms<br>0b111: Disabled  |

**I2C 1 (0xF06)**

| BIT         | 7               | 6              | 5 | 4 | 3 | 2              | 1 | 0 |
|-------------|-----------------|----------------|---|---|---|----------------|---|---|
| Field       | EN_I2C_LOOPBACK | G1_MST_BT[2:0] |   |   | – | G1_MST_TO[2:0] |   |   |
| Reset       | 0b0             | 0b101          |   |   | – | 0b110          |   |   |
| Access Type | Write, Read     | Write, Read    |   |   | – | Write, Read    |   |   |

| BITFIELD        | BITS | DESCRIPTION   | DECODE   |
|-----------------|------|---|--|
| EN_I2C_LOOPBACK | 7    | Enable I <sup>2</sup> C loopback between links in G1 + G2 or G1 + G1 aggregation mode. When I <sup>2</sup> C loopback is enabled, the I <sup>2</sup> C transactions generated at the leaf-end of on one link are reflected to the leaf-end of the other link  | 0x0: Disable loopback<br>0x1: Enable loopback  |
| G1_MST_BT       | 6:4  | GMSL1 I <sup>2</sup> C-to-I <sup>2</sup> C main bit rate setting configures the I <sup>2</sup> C bit rate used by the internal I <sup>2</sup> C main (in the device on remote side from the external I <sup>2</sup> C main)<br>Set this according to the I <sup>2</sup> C speed mode:<br>Fast-mode Plus = 101 to 111<br>Fast-mode = 010 to 101<br>Standard-mode = 000 to 010<br><br>Please see register groups CC_G2P* for GMSL2 registers. | 0b000: 9.92Kbps - Set for I <sup>2</sup> C Standard mode speed<br>0b001: 33.2Kbps - Set for I <sup>2</sup> C Standard mode speed<br>0b010: 99.2Kbps - Set for I <sup>2</sup> C standard or Fast-mode speed<br>0b011: 123Kbps - Set for I <sup>2</sup> C Fast-mode speed<br>0b100: 203Kbps - Set for I <sup>2</sup> C Fast-mode speed<br>0b101: 397Kbps - Set for I <sup>2</sup> C Fast or Fast-mode Plus speed<br>0b110: 625Kbps - Set for I <sup>2</sup> C Fast-mode Plus speed<br>0b111: 980Kbps - Set for I <sup>2</sup> C Fast-mode Plus speed |
| G1_MST_TO       | 2:0  | GMSL1 I <sup>2</sup> C-to-I <sup>2</sup> C main timeout setting<br>Internal GMSL1 I <sup>2</sup> C main times out after the configured duration if it does not receive any response while waiting for a packet from the remote device.<br><br>Please see register groups CC_G2P* for GMSL2 registers. (Addr. 0x500 - 0x6B0)   | 0b000: 16µs<br>0b001: 1ms<br>0b010: 2ms<br>0b011: 4ms<br>0b100: 8ms<br>0b101: 16ms<br>0b110: 32ms<br>0b111: Disabled   |

**I2C 2 (0xF07)**

| BIT         | 7             | 6 | 5 | 4 | 3 | 2 | 1 | 0 |
|-------------|---------------|---|---|---|---|---|---|---|
| Field       | G1_SRC_A[6:0] |   |   |   |   |   |   | – |
| Reset       | 0b0000000     |   |   |   |   |   |   | – |
| Access Type | Write, Read   |   |   |   |   |   |   | – |

| BITFIELD | BITS | DESCRIPTION  | DECODE                                      |
|----------|------|--|---|
| G1_SRC_A | 7:1  | GMSL1 I <sup>2</sup> C address translator source A<br>When I <sup>2</sup> C device address matches I <sup>2</sup> C SRC_A, internal I <sup>2</sup> C main (on remote side) replaces the device address with I <sup>2</sup> C DST_A.<br><br>Please see register groups CC_G2P* for GMSL2 registers. | 0bXXXXXXXX: Value of I <sup>2</sup> C SRC_A |

**I<sup>2</sup>C 3 (0xF08)**

| BIT         | 7             | 6 | 5 | 4 | 3 | 2 | 1 | 0 |
|-------------|---------------|---|---|---|---|---|---|---|
| Field       | G1_DST_A[6:0] |   |   |   |   |   |   | – |
| Reset       | 0b0000000     |   |   |   |   |   |   | – |
| Access Type | Write, Read   |   |   |   |   |   |   | – |

| BITFIELD | BITS | DESCRIPTION  | DECODE                                      |
|----------|------|--|---|
| G1_DST_A | 7:1  | GMSL1 I <sup>2</sup> C address translator destination A<br>See the description of I <sup>2</sup> C SRC_A.<br><br>Please see register groups CC_G2P* for GMSL2 registers. | 0bXXXXXXXX: Value of I <sup>2</sup> C DST_A |

**I<sup>2</sup>C 4 (0xF09)**

| BIT         | 7             | 6 | 5 | 4 | 3 | 2 | 1 | 0 |
|-------------|---------------|---|---|---|---|---|---|---|
| Field       | G1_SRC_B[6:0] |   |   |   |   |   |   | – |
| Reset       | 0b0000000     |   |   |   |   |   |   | – |
| Access Type | Write, Read   |   |   |   |   |   |   | – |

| BITFIELD | BITS | DESCRIPTION  | DECODE                                      |
|----------|------|--|---|
| G1_SRC_B | 7:1  | GMSL1 I <sup>2</sup> C address translator source B<br>When I <sup>2</sup> C device address matches I <sup>2</sup> C SRC_B, internal I <sup>2</sup> C main (on remote side) replaces the device address with I <sup>2</sup> C DST_B.<br><br>Please see register groups CC_G2P* for GMSL2 registers. | 0bXXXXXXXX: Value of I <sup>2</sup> C SRC_B |

**I2C 5 (0xF0A)**

| BIT         | 7             | 6 | 5 | 4 | 3 | 2 | 1 | 0 |
|-------------|---------------|---|---|---|---|---|---|---|
| Field       | G1_DST_B[6:0] |   |   |   |   |   |   | – |
| Reset       | 0b0000000     |   |   |   |   |   |   | – |
| Access Type | Write, Read   |   |   |   |   |   |   | – |

| BITFIELD | BITS | DESCRIPTION  | DECODE                                     |
|----------|------|--|--|
| G1_DST_B | 7:1  | GMSL1 I <sup>2</sup> C address translator destination B<br>See the description of I <sup>2</sup> C SRC_B.<br><br>Please see register groups CC_G2P* for GMSL2 registers. | 0bXXXXXXX: Value of I <sup>2</sup> C DST_B |

**SPI CC WR (0x1300)**

SPI data to write over the GMSL link. Use this address space to send write data across the GMSL link.

**SPI CC RD (0x1380)**

SPI data read over the GMSL link. Use this address space to read data sent across the GMSL link.

**RLMS3 (0x1403, 0x1503)**

| BIT         | 7           | 6 | 5 | 4 | 3 | 2 | 1 | 0 |
|-------------|-------------|---|---|---|---|---|---|---|
| Field       | AdaptEn     | – | – | – | – | – | – | – |
| Reset       | 0b0         | – | – | – | – | – | – | – |
| Access Type | Write, Read | – | – | – | – | – | – | – |

| BITFIELD | BITS | DESCRIPTION          | DECODE                      |
|----------|------|----------------------|-----------------------------|
| AdaptEn  | 7    | Adapt process enable | 0b0: Disable<br>0b1: Enable |

**RLMS4 (0x1404, 0x1504)**

| BIT         | 7                   | 6 | 5 | 4 | 3                | 2 | 1            | 0           |
|-------------|---------------------|---|---|---|------------------|---|--------------|-------------|
| Field       | EOM_CHK_AMOUNT[3:0] |   |   |   | EOM_CHK_THR[1:0] |   | EOM_PER_MODE | EOM_EN      |
| Reset       | 0x4                 |   |   |   | 0b10             |   | 0b1          | 0b1         |
| Access Type | Write, Read         |   |   |   | Write, Read      |   | Write, Read  | Write, Read |

| BITFIELD       | BITS | DESCRIPTION  | DECODE   |
|----------------|------|--|--|
| EOM_CHK_AMOUNT | 7:4  | A factor (N) used to select the order of number of observations in each eye-monitor window.<br><br>N is used in the equation:<br>Observations = $6.29 \times 10^{(N+2)}$ | 0xX: N factor  |
| EOM_CHK_THR    | 3:2  | Eye-opening monitor number of error bits allowed in a measurement window   | 0b00: Allow no errors<br>0b01: Allow one error<br>0b10: Allow two errors<br>0b11: Allow three errors |
| EOM_PER_MODE   | 1    | Eye-Opening Monitor Periodic Mode Enable   | 0b0: Eye-opening monitor periodic mode disabled<br>0b1: Eye-opening monitor periodic mode enabled    |
| EOM_EN         | 0    | Eye-Opening Monitor Enable   | 0b0: Eye-opening monitor disabled<br>0b1: Eye-opening monitor enabled                                |

**RLMS5 (0x1405, 0x1505)**

| BIT         | 7               | 6                | 5 | 4 | 3 | 2 | 1 | 0 |
|-------------|-----------------|------------------|---|---|---|---|---|---|
| Field       | EOM_MAN_TRG_REQ | EOM_MIN_THR[6:0] |   |   |   |   |   |   |
| Reset       | 0b0             | 0b0010000        |   |   |   |   |   |   |
| Access Type | Write Only      | Write, Read      |   |   |   |   |   |   |

| BITFIELD        | BITS | DESCRIPTION  | DECODE   |
|-----------------|------|--|--|
| EOM_MAN_TRG_REQ | 7    | Eye-Opening Monitor Manual Trigger<br><br>For use when periodic mode is disabled.  | 0b0: No action<br>0b1: EOM manual trigger request        |
| EOM_MIN_THR     | 6:0  | The eye-opening monitor minimum threshold as defined by the equation:<br>% eye opening = EOM_MIN_THR/64.<br>If the value is zero, the EOM is disabled. | 0bXXXXXXXX: Eye-opening monitor minimum threshold factor |

**RLMS6 (0x1406, 0x1506)**

| BIT         | 7           | 6                | 5 | 4 | 3 | 2 | 1 | 0 |
|-------------|-------------|------------------|---|---|---|---|---|---|
| Field       | EOM_PV_MODE | EOM_RST_THR[6:0] |   |   |   |   |   |   |
| Reset       | 0b1         | 0b0000000        |   |   |   |   |   |   |
| Access Type | Write, Read | Write, Read      |   |   |   |   |   |   |

| BITFIELD    | BITS | DESCRIPTION  | DECODE   |
|-------------|------|--|--|
| EOM_PV_MODE | 7    | Eye-opening is measured vertically or horizontally.  | 0b0: Vertical opening mode<br>0b1: Horizontal opening mode |
| EOM_RST_THR | 6:0  | The eye-opening monitor refresh threshold as defined by the equation:<br>% eye opening = EOM_MIN_THR/64.<br>If the value is zero, the EOM is disabled. | 0bXXXXXXX: EOM refresh threshold factor                    |

**RLMS7 (0x1407, 0x1507)**

| BIT         | 7         | 6         | 5 | 4 | 3 | 2 | 1 | 0 |
|-------------|-----------|-----------|---|---|---|---|---|---|
| Field       | EOM_DONE  | EOM[6:0]  |   |   |   |   |   |   |
| Reset       | 0b0       | 0b0000000 |   |   |   |   |   |   |
| Access Type | Read Only | Read Only |   |   |   |   |   |   |

| BITFIELD | BITS | DESCRIPTION                          | DECODE                                     |
|----------|------|--------------------------------------|--|
| EOM_DONE | 7    | Eye-Opening Monitor Measurement Done | 0b0: EOM not complete<br>0b1: EOM complete |
| EOM      | 6:0  | Last completed EOM observation       | 0bXXXXXXX: EOM measurement result          |

**RLMSA (0x140A, 0x150A)**

| BIT         | 7 | 6 | 5 | 4 | 3              | 2 | 1 | 0 |
|-------------|---|---|---|---|----------------|---|---|---|
| Field       | – | – | – | – | DFEAdpDly[3:0] |   |   |   |
| Reset       | – | – | – | – | 0x8            |   |   |   |
| Access Type | – | – | – | – | Write, Read    |   |   |   |

| BITFIELD  | BITS | DESCRIPTION   | DECODE                      |
|-----------|------|---|-----------------------------|
| DFEAdpDly | 3:0  | DFE adapt enable delay (milliseconds)<br>(default is 4 for slow receiver) | 0xXX: Delay in milliseconds |

**RLMSB (0x140B, 0x150B)**

| BIT         | 7              | 6 | 5 | 4 | 3 | 2 | 1 | 0 |
|-------------|----------------|---|---|---|---|---|---|---|
| Field       | AGCAcqDly[3:0] |   |   |   | – | – | – | – |
| Reset       | 0x4            |   |   |   | – | – | – | – |
| Access Type | Write, Read    |   |   |   | – | – | – | – |

| BITFIELD  | BITS | DESCRIPTION                                  | DECODE  |
|-----------|------|--|---|
| AGCAcqDly | 7:4  | AGC Acquisition Delay decode: (milliseconds) | 0x0: 1ms<br>0x1: 2ms<br>0x2: 3ms<br>0x3: 4ms<br>0x4: 5ms<br>0x5: 6ms<br>0x6: 7ms<br>0x7: 8ms<br>0x8: 9ms<br>0x9: 10ms<br>0xA: 12ms<br>0xB: 15ms<br>0xC: 20ms<br>0xD: 25ms<br>0xE: 32ms<br>0xF: 63ms |

**RLMS18 (0x1418, 0x1518)**

| BIT         | 7 | 6 | 5 | 4 | 3 | 2           | 1 | 0 |
|-------------|---|---|---|---|---|-------------|---|---|
| Field       | - | - | - | - | - | VgaHiGain   | - | - |
| Reset       | - | - | - | - | - | 0b1         | - | - |
| Access Type | - | - | - | - | - | Write, Read | - | - |

| BITFIELD  | BITS | DESCRIPTION  | DECODE   |
|-----------|------|--|--|
| VgaHiGain | 2    | 55nm FR VGA has an addition gain stage instead of the FFE stage. This control bit (VgaHiGain) configures this gain stage to track the other stages or operate in a high-gain mode. | 0: High Gain Stage Tracks VGA<br>1: VGA High Gain Stage Mode |

**RLMS1F (0x141F, 0x151F)**

| BIT         | 7              | 6 | 5 | 4 | 3 | 2 | 1 | 0 |
|-------------|----------------|---|---|---|---|---|---|---|
| Field       | AGCInitG2[7:0] |   |   |   |   |   |   |   |
| Reset       | 0xA7           |   |   |   |   |   |   |   |
| Access Type | Write, Read    |   |   |   |   |   |   |   |

| BITFIELD  | BITS | DESCRIPTION                   | DECODE                                   |
|-----------|------|-------------------------------|--|
| AGCInitG2 | 7:0  | AGC initial value for G2 mode | 0x00: Maximum gain<br>0xFF: Minimum gain |

**RLMS21 (0x1421, 0x1521)**

| BIT         | 7 | 6 | 5           | 4 | 3 | 2 | 1 | 0 |
|-------------|---|---|-------------|---|---|---|---|---|
| Field       | – | – | BSTMuH[5:0] |   |   |   |   |   |
| Reset       | – | – | 0b000100    |   |   |   |   |   |
| Access Type | – | – | Write, Read |   |   |   |   |   |

| BITFIELD | BITS | DESCRIPTION        | DECODE                    |
|----------|------|--------------------|---------------------------|
| BSTMuH   | 5:0  | BST adapt gain MSB | 0xXX: BST adapt gain MSBs |

**RLMS23 (0x1423, 0x1523)**

| BIT         | 7 | 6 | 5            | 4 | 3 | 2 | 1 | 0 |
|-------------|---|---|--------------|---|---|---|---|---|
| Field       | – | – | BSTInit[5:0] |   |   |   |   |   |
| Reset       | – | – | 0b000101     |   |   |   |   |   |
| Access Type | – | – | Write, Read  |   |   |   |   |   |

| BITFIELD | BITS | DESCRIPTION   | DECODE                  |
|----------|------|---|-------------------------|
| BSTInit  | 5:0  | BST initial value<br>(Default is 0 for slow receiver) | 0xXX: BST initial value |

**RLMS31 (0x1431, 0x1531)**

| BIT         | 7 | 6 | 5           | 4 | 3 | 2 | 1 | 0 |
|-------------|---|---|-------------|---|---|---|---|---|
| Field       | – | – | OSNMuH[5:0] |   |   |   |   |   |
| Reset       | – | – | 0b011000    |   |   |   |   |   |
| Access Type | – | – | Write, Read |   |   |   |   |   |

| BITFIELD | BITS | DESCRIPTION        | DECODE                    |
|----------|------|--------------------|---------------------------|
| OSNMuH   | 5:0  | OSN adapt gain MSB | 0xXX: OSN adapt gain MSBs |

**RLMS3E (0x143E, 0x153E)**

| BIT   | 7                | 6                   | 5 | 4 | 3 | 2 | 1 | 0 |
|-------|------------------|---------------------|---|---|---|---|---|---|
| Field | ErrChPhSecTAFR6G | ErrChPhSecFR6G[6:0] |   |   |   |   |   |   |

|                    |             |             |
|--------------------|-------------|-------------|
| <b>Reset</b>       | 0b1         | 0b0010100   |
| <b>Access Type</b> | Write, Read | Write, Read |

| BITFIELD         | BITS | DESCRIPTION   | DECODE  |
|------------------|------|---|---|
| ErrChPhSecTAFR6G | 7    | Error channel phase secondary timing adjust                   | 0b0: Sample on rising clock edge<br>0b1: Sample on falling clock edge |
| ErrChPhSecFR6G   | 6:0  | Error channel sampling point phase adjustment secondary (odd) | 0xXX: 2 UI / 127  |

**RLMS3F (0x143F, 0x153F)**

| BIT                | 7                | 6                   | 5 | 4 | 3 | 2 | 1 | 0 |
|--------------------|------------------|---------------------|---|---|---|---|---|---|
| <b>Field</b>       | ErrChPhPriTAFR6G | ErrChPhPriFR6G[6:0] |   |   |   |   |   |   |
| <b>Reset</b>       | 0b0              | 0b1010100           |   |   |   |   |   |   |
| <b>Access Type</b> | Write, Read      | Write, Read         |   |   |   |   |   |   |

| BITFIELD         | BITS | DESCRIPTION  | DECODE  |
|------------------|------|--|---|
| ErrChPhPriTAFR6G | 7    | Error channel phase primary timing adjust                    | 0b0: Sample on rising clock edge<br>0b1: Sample on falling clock edge |
| ErrChPhPriFR6G   | 6:0  | Error channel sampling point phase adjustment primary (even) | 0xXX: 2 UI / 127  |

**RLMS45 (0x1445, 0x1545)**

| BIT                | 7             | 6             | 5 | 4 | 3 | 2 | 1 | 0 |
|--------------------|---------------|---------------|---|---|---|---|---|---|
| <b>Field</b>       | CRULpCtrlSREn | CRUSSCSelSREn | – | – | – | – | – | – |
| <b>Reset</b>       | 0b1           | 0b1           | – | – | – | – | – | – |
| <b>Access Type</b> | Write, Read   | Write, Read   | – | – | – | – | – | – |

| BITFIELD      | BITS | DESCRIPTION   | DECODE  |
|---------------|------|---|---|
| CRULpCtrlSREn | 7    | Override enable for CRU Loop control. When override is enabled, the user-programmed CRULpCtrl register value (in RLMS46 register) is used for CRU Loop control. | 0: Override is disabled<br>1: Override is enabled |
| CRUSSCSelSREn | 6    | Override enable for CRU SSC SEL for Slow Receiver only  | 0b0: Disable<br>0b1: Enable                       |

**RLMS46 (0x1446, 0x1546)**

| BIT | 7 | 6 | 5 | 4 | 3 | 2 | 1 | 0 |
|-----|---|---|---|---|---|---|---|---|
|-----|---|---|---|---|---|---|---|---|

|             |   |   |   |   |   |                |
|-------------|---|---|---|---|---|----------------|
| Field       | – | – | – | – | – | CRULpCtrl[2:0] |
| Reset       | – | – | – | – | – | 0b011          |
| Access Type | – | – | – | – | – | Write, Read    |

| BITFIELD  | BITS | DESCRIPTION   | DECODE   |
|-----------|------|---|--|
| CRULpCtrl | 2:0  | CRU loop control for Fast Receiver and Slow Receiver<br>For Slow Receiver Rate, if override is disabled, following values are used:<br>Rate 11=101<br>Rate 10=011<br>Rate 01=001<br>Rate 00=000 | 0b000: 1 CRU edge (highest bandwidth)<br>0b001: 2 CRU edges<br>0b010: 1 CRU edge<br>0b011: 4 CRU edges (default setting)<br>0b100: 4 CRU edges<br>0b101: 8 CRU edges<br>0b110: 4 CRU edges<br>0b111: 16 CRU edges (lowest bandwidth) |

**RLMS47 (0x1447, 0x1547)**

|             |   |   |   |   |   |                |   |   |
|-------------|---|---|---|---|---|----------------|---|---|
| BIT         | 7 | 6 | 5 | 4 | 3 | 2              | 1 | 0 |
| Field       | – | – | – | – | – | CRUSSCSeI[1:0] |   | – |
| Reset       | – | – | – | – | – | 0b01           |   | – |
| Access Type | – | – | – | – | – | Write, Read    |   | – |

| BITFIELD  | BITS | DESCRIPTION   |
|-----------|------|---|
| CRUSSCSeI | 2:1  | CRU spread spectrum adjust select<br>For Slow Receiver while override is disabled<br>Rate 11=10<br>Rate 10=10<br>Rate 01=01<br>Rate 00=01 |

**RLMS49 (0x1449, 0x1549)**

|             |   |   |   |   |   |             |   |   |
|-------------|---|---|---|---|---|-------------|---|---|
| BIT         | 7 | 6 | 5 | 4 | 3 | 2           | 1 | 0 |
| Field       | – | – | – | – | – | ErrChPwrUp  | – | – |
| Reset       | – | – | – | – | – | 0b1         | – | – |
| Access Type | – | – | – | – | – | Write, Read | – | – |

| BITFIELD   | BITS | DESCRIPTION              | DECODE   |
|------------|------|--------------------------|--|
| ErrChPwrUp | 2    | Error channel power down | 0b0: Periodically power down<br>0b1: Remain powered up |

**RLMS64 (0x1464, 0x1564)**

| BIT         | 7 | 6 | 5 | 4 | 3 | 2 | 1              | 0 |
|-------------|---|---|---|---|---|---|----------------|---|
| Field       | – | – | – | – | – | – | TxSSCMode[1:0] |   |
| Reset       | – | – | – | – | – | – | 0b00           |   |
| Access Type | – | – | – | – | – | – | Write, Read    |   |

| BITFIELD  | BITS | DESCRIPTION             | DECODE  |
|-----------|------|-------------------------|---|
| TxSSCMode | 1:0  | Tx Spread Spectrum Mode | 00: Spread spectrum disabled<br>01: Reserved<br>10: Reserved<br>11: Spread spectrum enabled (center spread) |

**RLMS70 (0x1470, 0x1570)**

| BIT         | 7 | 6                 | 5 | 4 | 3 | 2 | 1 | 0 |
|-------------|---|-------------------|---|---|---|---|---|---|
| Field       | – | TxSSCFrqCtrl[6:0] |   |   |   |   |   |   |
| Reset       | – | 0b0000001         |   |   |   |   |   |   |
| Access Type | – | Write, Read       |   |   |   |   |   |   |

| BITFIELD     | BITS | DESCRIPTION   | DECODE  |
|--------------|------|---|---|
| TxSSCFrqCtrl | 6:0  | Tx SSC modulation amplitude (frequency deviation) control | 0x07: SSC 268 PPM<br>0x06: SSC 580 PPM<br>0x03: SSC 970 PPM<br>0x01: SSC 1750 PPM<br>0x01: SSC 2530 PPM<br>Others: Reserved |

**RLMS71 (0x1471, 0x1571)**

| BIT         | 7 | 6                  | 5 | 4 | 3 | 2 | 1 | 0           |
|-------------|---|--------------------|---|---|---|---|---|-------------|
| Field       | – | TxSSCCenSprSt[5:0] |   |   |   |   |   | TxSSCEn     |
| Reset       | – | 0b000001           |   |   |   |   |   | 0b0         |
| Access Type | – | Write, Read        |   |   |   |   |   | Write, Read |

| BITFIELD      | BITS | DESCRIPTION                         | DECODE  |
|---------------|------|-------------------------------------|---|
| TxSSCCenSprSt | 6:1  | Tx SSC center spread starting phase | 0x02: Set this value if SSC Generation is enabled (RLMS64)<br>0x00: Otherwise |
| TxSSCEn       | 0    | Tx spread spectrum enable           | 0b0: Tx spread spectrum disabled<br>0b1: Tx spread spectrum enabled           |

**RLMS72 (0x1472, 0x1572)**

| BIT         | 7                | 6 | 5 | 4 | 3 | 2 | 1 | 0 |
|-------------|------------------|---|---|---|---|---|---|---|
| Field       | TxSSCPreScL[7:0] |   |   |   |   |   |   |   |
| Reset       | 0xCF             |   |   |   |   |   |   |   |
| Access Type | Write, Read      |   |   |   |   |   |   |   |

| BITFIELD    | BITS | DESCRIPTION  | DECODE  |
|-------------|------|--|---|
| TxSSCPreScL | 7:0  | Tx SSC frequency prescaler bits 7:0. Decode values are for bits 7:0, concatenate with TXSSCPreScH for final value. | 0xC9: SSC 268 PPM<br>0xAB: SSC 580 PPM<br>0xAB: SSC 970 PPM<br>0xF9: SSC 1750 PPM<br>0xAB: SSC 2530 PPM<br>Others: Reserved |

**RLMS73 (0x1473, 0x1573)**

| BIT         | 7 | 6 | 5 | 4 | 3 | 2                | 1 | 0 |
|-------------|---|---|---|---|---|------------------|---|---|
| Field       | - | - | - | - | - | TxSSCPreScH[2:0] |   |   |
| Reset       | - | - | - | - | - | 0b000            |   |   |
| Access Type | - | - | - | - | - | Write, Read      |   |   |

| BITFIELD    | BITS | DESCRIPTION  | DECODE  |
|-------------|------|--|---|
| TxSSCPreScH | 2:0  | Tx SSC frequency prescaler bits 10:8. Decode values are for bits 10:8, concatenate with TXSSCPreScL for final value. | 0x02: SSC 268 PPM<br>0x00: SSC 580 PPM<br>0x00: SSC 970 PPM<br>0x00: SSC 1750 PPM<br>0x00: SSC 2530 PPM<br>Others: Reserved |

**RLMS74 (0x1474, 0x1574)**

| BIT         | 7             | 6 | 5 | 4 | 3 | 2 | 1 | 0 |
|-------------|---------------|---|---|---|---|---|---|---|
| Field       | TxSSCPhL[7:0] |   |   |   |   |   |   |   |
| Reset       | 0x00          |   |   |   |   |   |   |   |
| Access Type | Write, Read   |   |   |   |   |   |   |   |

| BITFIELD | BITS | DESCRIPTION   | DECODE  |
|----------|------|---|---|
| TxSSCPhL | 7:0  | Tx SSC phase accumulator increment bits 7:0. Decode values are for bits 7:0, concatenate with TXSSCPhH for final value. | 0xF9: SSC 268 PPM<br>0x63: SSC 580 PPM<br>0x63: SSC 970 PPM<br>0x2C: SSC 1750 PPM |

| BITFIELD | BITS | DESCRIPTION | DECODE                                 |
|----------|------|-------------|--|
|          |      |             | 0x63: SSC 2530 PPM<br>Others: Reserved |

**RLMS75 (0x1475, 0x1575)**

| BIT         | 7 | 6            | 5 | 4 | 3 | 2 | 1 | 0 |
|-------------|---|--------------|---|---|---|---|---|---|
| Field       | – | TxSSCPH[6:0] |   |   |   |   |   |   |
| Reset       | – | 0b0000000    |   |   |   |   |   |   |
| Access Type | – | Write, Read  |   |   |   |   |   |   |

| BITFIELD | BITS | DESCRIPTION   | DECODE   |
|----------|------|---|--|
| TxSSCPH  | 6:0  | Tx SSC phase accumulator increment bits 14:8. Decode values are for bits 14:8, concatenate with TXSSCPHL for final value. | 0x01: If SSC Generation enabled (RLMS64) and desired spread is 268 PPM<br>0x07: If SSC Generation enabled (RLMS64) and desired spread is 580 PPM<br>0x07: If SSC Generation enabled (RLMS64) and desired spread is 970 PPM<br>0x05: If SSC Generation enabled (RLMS64) and desired spread is 1750 PPM<br>0x07: If SSC Generation enabled (RLMS64) and desired spread is 2530 PPM<br>Others: Reserved |

**RLMS76 (0x1476, 0x1576)**

| BIT         | 7                     | 6 | 5 | 4                      | 3 | 2 | 1                | 0 |
|-------------|-----------------------|---|---|------------------------|---|---|------------------|---|
| Field       | phyc_rep_ecp_dly[2:0] |   |   | phyc_ecp_cal_time[2:0] |   |   | TxSSCPHQuad[1:0] |   |
| Reset       | 0b100                 |   |   | 0b100                  |   |   | 0b00             |   |
| Access Type | Write, Read           |   |   | Write, Read            |   |   | Write, Read      |   |

| BITFIELD          | BITS | DESCRIPTION                      | DECODE  |
|-------------------|------|----------------------------------|---|
| phyc_rep_ecp_dly  | 7:5  | Repetitive ECP calibration delay | 0x0: Repetitive ECP calibration disabled<br>0x1: 2ms<br>0x2: 4ms<br>0x3: 6ms<br>0x4: 8ms<br>0x5: 12ms<br>0x6: 16ms<br>0x7: 20ms |
| phyc_ecp_cal_time | 4:2  | ECP calibration active time      | 0x0: 8µs<br>0x1: 32µs<br>0x2: 64µs<br>0x3: 128µs<br>0x4: 256µs<br>0x5: 512µs<br>0x6: 1024µs<br>0x7: 2048µs                      |

| BITFIELD    | BITS | DESCRIPTION                          | DECODE       |
|-------------|------|--------------------------------------|--------------|
| TxSSCPhQuad | 1:0  | Tx SSC phase starting phase quadrant | 0x00: Always |

**RLMS8C (0x148C, 0x158C)**

| BIT         | 7 | 6                     | 5 | 4 | 3 | 2 | 1 | 0 |
|-------------|---|-----------------------|---|---|---|---|---|---|
| Field       | – | cap_pre_out_rlms[6:0] |   |   |   |   |   |   |
| Reset       | – | 0b0000000             |   |   |   |   |   |   |
| Access Type | – | Write, Read           |   |   |   |   |   |   |

| BITFIELD         | BITS | DESCRIPTION                                | DECODE                 |
|------------------|------|--|------------------------|
| cap_pre_out_rlms | 6:0  | cap_preout value during RLMS if overridden | 0xXX: cap_preout value |

**RLMS95 (0x1495, 0x1595)**

| BIT         | 7           | 6 | 5             | 4 | 3 | 2 | 1 | 0 |
|-------------|-------------|---|---------------|---|---|---|---|---|
| Field       | TxAmpManEn  | – | TxAmpMan[5:0] |   |   |   |   |   |
| Reset       | 0b0         | – | 0b101001      |   |   |   |   |   |
| Access Type | Write, Read | – | Write, Read   |   |   |   |   |   |

| BITFIELD   | BITS | DESCRIPTION                  | DECODE  |
|------------|------|------------------------------|---|
| TxAmpManEn | 7    | TX amplitude manual override | 0: Do not manually override TX amplitude<br>1: Manually override TX amplitude |
| TxAmpMan   | 5:0  | TX amplitude                 | 0bXXXXXX: Binary amplitude 10mV per count                                     |

**RLMS98 (0x1498, 0x1598)**

| BIT         | 7                  | 6 | 5 | 4 | 3 | 2 | 1 | 0 |
|-------------|--------------------|---|---|---|---|---|---|---|
| Field       | Cal_cap_pre_out_en | – | – | – | – | – | – | – |
| Reset       | 0b0                | – | – | – | – | – | – | – |
| Access Type | Write, Read        | – | – | – | – | – | – | – |

| BITFIELD           | BITS | DESCRIPTION  | DECODE                      |
|--------------------|------|--|-----------------------------|
| Cal_cap_pre_out_en | 7    | Enable manual override for cap_pre_out during RLMS | 0b0: Disable<br>0b1: Enable |

**RLMSA4 (0x14A4, 0x15A4)**

| BIT         | 7                 | 6 | 5            | 4 | 3 | 2 | 1 | 0 |
|-------------|-------------------|---|--------------|---|---|---|---|---|
| Field       | AEQ_PER_MULT[1:0] |   | AEQ_PER[5:0] |   |   |   |   |   |
| Reset       | 0b10              |   | 0b111101     |   |   |   |   |   |
| Access Type | Write, Read       |   | Write, Read  |   |   |   |   |   |

| BITFIELD     | BITS | DESCRIPTION  | DECODE                                     |
|--------------|------|--|--|
| AEQ_PER_MULT | 7:6  | Adaptive EQ period multiplier  | 00: 1ms<br>01: 4ms<br>10: 16ms<br>11: 64ms |
| AEQ_PER      | 5:0  | Adaptive EQ period<br>Periodic adaptation is disabled when value is 0.<br>Adaptive EQ period is (AEQ_PER value times<br>AEQ_PER_MULT). |  |

**RLMSA5 (0x14A5, 0x15A5)**

| BIT         | 7 | 6 | 5                    | 4 | 3 | 2 | 1 | 0 |
|-------------|---|---|----------------------|---|---|---|---|---|
| Field       | – | – | PHYC_WBLOCK_DLY[1:0] |   | – | – | – | – |
| Reset       | – | – | 0b01                 |   | – | – | – | – |
| Access Type | – | – | Write, Read          |   | – | – | – | – |

| BITFIELD        | BITS | DESCRIPTION                                   | DECODE  |
|-----------------|------|---|---|
| PHYC_WBLOCK_DLY | 5:4  | PHY controller word boundary lock start delay | 00: 16ms<br>01: 32ms (default)<br>10: 64ms<br>11: 128ms |

**RLMSA7 (0x14A7, 0x15A7)**

| BIT         | 7           | 6 | 5 | 4 | 3 | 2 | 1 | 0 |
|-------------|-------------|---|---|---|---|---|---|---|
| Field       | MAN_CTRL_EN | – | – | – | – | – | – | – |
| Reset       | 0b0         | – | – | – | – | – | – | – |
| Access Type | Write, Read | – | – | – | – | – | – | – |

| BITFIELD    | BITS | DESCRIPTION                       | DECODE  |
|-------------|------|-----------------------------------|---|
| MAN_CTRL_EN | 7    | PHY controller manual mode enable | 0b0: PHY controller manual mode disabled<br>0b1: PHY controller manual mode enabled |

**RLMSA8 (0x14A8, 0x15A8)**

| BIT         | 7           | 6            | 5           | 4 | 3 | 2 | 1 | 0 |
|-------------|-------------|--------------|-------------|---|---|---|---|---|
| Field       | FW_PHY_CTRL | FW_PHY_PU_TX | FW_PHY_RSTB | – | – | – | – | – |
| Reset       | 0b0         | 0b0          | 0b0         | – | – | – | – | – |
| Access Type | Write, Read | Write, Read  | Write, Read | – | – | – | – | – |

| BITFIELD     | BITS | DESCRIPTION                         | DECODE                                       |
|--------------|------|-------------------------------------|--|
| FW_PHY_CTRL  | 7    | PHY controller firmware mode enable | 0b0: Disable<br>0b1: Enable                  |
| FW_PHY_PU_TX | 6    | Override PHY controller output      | 0b0: Power-down TX<br>0b1: Power-up TX       |
| FW_PHY_RSTB  | 5    | Override PHY controller output      | 0b0: Reset asserted<br>0b1: Reset deasserted |

**RLMSA9 (0x14A9, 0x15A9)**

| BIT         | 7              | 6 | 5              | 4           | 3           | 2 | 1 | 0 |
|-------------|----------------|---|----------------|-------------|-------------|---|---|---|
| Field       | FW_REPCAL_RSTB | – | FW_TXD_SQUELCH | FW_TXD_EN   | FW_RXD_EN   | – | – | – |
| Reset       | 0b0            | – | 0b0            | 0b0         | 0b0         | – | – | – |
| Access Type | Write, Read    | – | Write, Read    | Write, Read | Write, Read | – | – | – |

| BITFIELD       | BITS | DESCRIPTION                    | DECODE                                       |
|----------------|------|--------------------------------|--|
| FW_REPCAL_RSTB | 7    | Override PHY controller output | 0b0: Reset asserted<br>0b1: Reset deasserted |
| FW_TXD_SQUELCH | 5    | Override PHY controller output | 0b0: Disable<br>0b1: Enable                  |
| FW_TXD_EN      | 4    | Override PHY controller output | 0b0: Disable<br>0b1: Enable                  |
| FW_RXD_EN      | 3    | Override PHY controller output | 0b0: Disable<br>0b1: Enable                  |

**RLMSAC (0x14AC, 0x15AC)**

| BIT         | 7 | 6                   | 5 | 4 | 3 | 2 | 1 | 0 |
|-------------|---|---------------------|---|---|---|---|---|---|
| Field       | – | ErrChPhSecFR3G[6:0] |   |   |   |   |   |   |
| Reset       | – | 0b0100000           |   |   |   |   |   |   |
| Access Type | – | Write, Read         |   |   |   |   |   |   |

| BITFIELD       | BITS | DESCRIPTION                         | DECODE                      |
|----------------|------|-------------------------------------|-----------------------------|
| ErrChPhSecFR3G | 6:0  | Error channel phase secondary (odd) | 0xXX: Phase secondary value |

**RLMSAD (0x14AD, 0x15AD)**

| BIT         | 7 | 6                   | 5 | 4 | 3 | 2 | 1 | 0 |
|-------------|---|---------------------|---|---|---|---|---|---|
| Field       | – | ErrChPhPriFR3G[6:0] |   |   |   |   |   |   |
| Reset       | – | 0b1100000           |   |   |   |   |   |   |
| Access Type | – | Write, Read         |   |   |   |   |   |   |

| BITFIELD       | BITS | DESCRIPTION                        | DECODE                    |
|----------------|------|------------------------------------|---------------------------|
| ErrChPhPriFR3G | 6:0  | Error channel phase primary (even) | 0xXX: Phase primary value |

**DPLL 0 (0x1C00)**

| BIT         | 7 | 6 | 5 | 4 | 3 | 2 | 1 | 0                 |
|-------------|---|---|---|---|---|---|---|-------------------|
| Field       | – | – | – | – | – | – | – | config_soft_rst_n |
| Reset       | – | – | – | – | – | – | – | 0b1               |
| Access Type | – | – | – | – | – | – | – | Write, Read       |

| BITFIELD          | BITS | DESCRIPTION   | DECODE                                       |
|-------------------|------|---|--|
| config_soft_rst_n | 0    | Setting this to 0 resets the PLL functional registers, config_regs are not reset. | 0b0: Reset asserted<br>0b1: Reset deasserted |

**DPLL 3 (0x1C03)**

| BIT         | 7                                  | 6                          | 5                                    | 4                                   | 3 | 2 | 1 | 0 |
|-------------|------------------------------------|----------------------------|--------------------------------------|-------------------------------------|---|---|---|---|
| Field       | config_sel_clock_out_use_ext_ernal | config_disable_div_out_exp | config_use_internal_pll_mode_v alues | config_use_internal_divider_v alues | – | – | – | – |
| Reset       | 0b1                                | 0b0                        | 0b0                                  | 0b0                                 | – | – | – | – |
| Access Type | Write, Read                        | Write, Read                | Write, Read                          | Write, Read                         | – | – | – | – |

| BITFIELD                            | BITS | DESCRIPTION   | DECODE                      |
|-------------------------------------|------|---|-----------------------------|
| config_sel_clock_out_use_external   | 7    | When 1, i_sel_clock_out is used to select output clock. Otherwise, internal registers are used. |                             |
| config_disable_div_out_exp          | 6    | Forces div_out_exp to 7, which disables the divider   | 0b0: Disable<br>0b1: Enable |
| config_use_internal_pll_mode_values | 5    | Bypasses internal pll_mode controls and uses config_reg values                                  | 0b0: Disable<br>0b1: Enable |
| config_use_internal_divider_values  | 4    | Forces all divider values to come from internal controls  | 0b0: Disable<br>0b1: Enable |

**DPLL 7 (0x1C07)**

| BIT         | 7               | 6                  | 5 | 4 | 3 | 2 | 1 | 0 |   |
|-------------|-----------------|--------------------|---|---|---|---|---|---|---|
| Field       | config_div_fb_L | config_div_in[4:0] |   |   |   |   |   | – | – |
| Reset       | 0b0             | 0b00001            |   |   |   |   |   | – | – |
| Access Type | Write, Read     | Write, Read        |   |   |   |   |   | – | – |

| BITFIELD        | BITS | DESCRIPTION  |
|-----------------|------|--|
| config_div_fb_L | 7    | Sets the feedback divider value when i_div_use_external = 0                                |
| config_div_in   | 6:2  | Sets the divide value of the input divider connected to i_clk_in, the main PLL clock input |

**DPLL 8 (0x1C08)**

| BIT         | 7                    | 6 | 5 | 4 | 3 | 2 | 1 | 0 |  |
|-------------|----------------------|---|---|---|---|---|---|---|--|
| Field       | config_div_fb_H[7:0] |   |   |   |   |   |   |   |  |
| Reset       | 0x14                 |   |   |   |   |   |   |   |  |
| Access Type | Write, Read          |   |   |   |   |   |   |   |  |

| BITFIELD        | BITS | DESCRIPTION   |
|-----------------|------|---|
| config_div_fb_H | 7:0  | Sets the feedback divider value when i_div_use_external = 0 |

**DPLL 10 (0x1C0A)**

| BIT   | 7 | 6                       | 5 | 4 | 3 | 2 | 1 | 0 |
|-------|---|-------------------------|---|---|---|---|---|---|
| Field | – | config_div_out_exp[2:0] |   |   | – | – | – | – |
| Reset | – | 0b000                   |   |   | – | – | – | – |

|                    |   |             |   |   |   |   |
|--------------------|---|-------------|---|---|---|---|
| <b>Access Type</b> | – | Write, Read | – | – | – | – |
|--------------------|---|-------------|---|---|---|---|

| <b>BITFIELD</b>    | <b>BITS</b> | <b>DESCRIPTION</b>  |
|--------------------|-------------|---|
| config_div_out_exp | 6:4         | Sets the output exponential divider value when i_div_use_external = 0 |

**DPLL 0 (0x1D00)**

| <b>BIT</b>         | <b>7</b> | <b>6</b> | <b>5</b> | <b>4</b> | <b>3</b> | <b>2</b> | <b>1</b> | <b>0</b>          |
|--------------------|----------|----------|----------|----------|----------|----------|----------|-------------------|
| <b>Field</b>       | –        | –        | –        | –        | –        | –        | –        | config_soft_rst_n |
| <b>Reset</b>       | –        | –        | –        | –        | –        | –        | –        | 0b1               |
| <b>Access Type</b> | –        | –        | –        | –        | –        | –        | –        | Write, Read       |

| <b>BITFIELD</b>   | <b>BITS</b> | <b>DESCRIPTION</b>  | <b>DECODE</b>                                |
|-------------------|-------------|---|--|
| config_soft_rst_n | 0           | Setting this to 0 resets the PLL functional registers, config_regs are not reset. | 0b0: Reset asserted<br>0b1: Reset deasserted |

**DPLL 3 (0x1D03)**

| <b>BIT</b>         | <b>7</b>                              | <b>6</b>                       | <b>5</b>                                | <b>4</b>                               | <b>3</b> | <b>2</b> | <b>1</b> | <b>0</b> |
|--------------------|---------------------------------------|--------------------------------|---|--|----------|----------|----------|----------|
| <b>Field</b>       | config_sel_clock_out_use_ext<br>ernal | config_disable_div_out_<br>exp | config_use_internal_pll_mode_v<br>alues | config_use_internal_divider_v<br>alues | –        | –        | –        | –        |
| <b>Reset</b>       | 0b1                                   | 0b0                            | 0b0                                     | 0b0                                    | –        | –        | –        | –        |
| <b>Access Type</b> | Write, Read                           | Write, Read                    | Write, Read                             | Write, Read                            | –        | –        | –        | –        |

| <b>BITFIELD</b>                     | <b>BITS</b> | <b>DESCRIPTION</b>  | <b>DECODE</b>               |
|-------------------------------------|-------------|---|-----------------------------|
| config_sel_clock_out_use_external   | 7           | When 1, i_sel_clock_out is used to select output clock. Otherwise, internal registers are used. |                             |
| config_disable_div_out_exp          | 6           | Forces div_out_exp to 7, which disables the divider   | 0b0: Disable<br>0b1: Enable |
| config_use_internal_pll_mode_values | 5           | Bypasses internal pll_mode controls and uses config_reg values                                  | 0b0: Disable<br>0b1: Enable |
| config_use_internal_divider_values  | 4           | Forces all divider values to come from internal controls  | 0b0: Disable<br>0b1: Enable |

**DPLL 7 (0x1D07)**

| <b>BIT</b> | <b>7</b> | <b>6</b> | <b>5</b> | <b>4</b> | <b>3</b> | <b>2</b> | <b>1</b> | <b>0</b> |
|------------|----------|----------|----------|----------|----------|----------|----------|----------|
|------------|----------|----------|----------|----------|----------|----------|----------|----------|

|                    |                 |                    |   |   |
|--------------------|-----------------|--------------------|---|---|
| <b>Field</b>       | config_div_fb_L | config_div_in[4:0] | - | - |
| <b>Reset</b>       | 0b0             | 0b00001            | - | - |
| <b>Access Type</b> | Write, Read     | Write, Read        | - | - |

| BITFIELD        | BITS | DESCRIPTION  |
|-----------------|------|--|
| config_div_fb_L | 7    | Sets the feedback divider value when i_div_use_external = 0                                |
| config_div_in   | 6:2  | Sets the divide value of the input divider connected to i_clk_in, the main PLL clock input |

**DPLL 8 (0x1D08)**

| BIT                | 7                    | 6 | 5 | 4 | 3 | 2 | 1 | 0 |
|--------------------|----------------------|---|---|---|---|---|---|---|
| <b>Field</b>       | config_div_fb_H[7:0] |   |   |   |   |   |   |   |
| <b>Reset</b>       | 0x14                 |   |   |   |   |   |   |   |
| <b>Access Type</b> | Write, Read          |   |   |   |   |   |   |   |

| BITFIELD        | BITS | DESCRIPTION   |
|-----------------|------|---|
| config_div_fb_H | 7:0  | Sets the feedback divider value when i_div_use_external = 0 |

**DPLL 10 (0x1D0A)**

| BIT                | 7 | 6                       | 5 | 4 | 3 | 2 | 1 | 0 |
|--------------------|---|-------------------------|---|---|---|---|---|---|
| <b>Field</b>       | - | config_div_out_exp[2:0] |   |   | - | - | - | - |
| <b>Reset</b>       | - | 0b000                   |   |   | - | - | - | - |
| <b>Access Type</b> | - | Write, Read             |   |   | - | - | - | - |

| BITFIELD           | BITS | DESCRIPTION   |
|--------------------|------|---|
| config_div_out_exp | 6:4  | Sets the output exponential divider value when i_div_use_external = 0 |

**DPLL 0 (0x1E00)**

| BIT          | 7 | 6 | 5 | 4 | 3 | 2 | 1 | 0                 |
|--------------|---|---|---|---|---|---|---|-------------------|
| <b>Field</b> | - | - | - | - | - | - | - | config_soft_rst_n |
| <b>Reset</b> | - | - | - | - | - | - | - | 0b1               |

|             |   |   |   |   |   |   |   |             |
|-------------|---|---|---|---|---|---|---|-------------|
| Access Type | - | - | - | - | - | - | - | Write, Read |
|-------------|---|---|---|---|---|---|---|-------------|

| BITFIELD          | BITS | DESCRIPTION   | DECODE                                       |
|-------------------|------|---|--|
| config_soft_rst_n | 0    | Setting this to 0 resets the PLL functional registers, config_regs are not reset. | 0b0: Reset asserted<br>0b1: Reset deasserted |

**DPLL 3 (0x1E03)**

| BIT         | 7                                  | 6                          | 5                                    | 4                                   | 3 | 2 | 1 | 0 |
|-------------|------------------------------------|----------------------------|--------------------------------------|-------------------------------------|---|---|---|---|
| Field       | config_sel_clock_out_use_ext_ernal | config_disable_div_out_exp | config_use_internal_pll_mode_v alues | config_use_internal_divider_v alues | - | - | - | - |
| Reset       | 0b1                                | 0b0                        | 0b0                                  | 0b0                                 | - | - | - | - |
| Access Type | Write, Read                        | Write, Read                | Write, Read                          | Write, Read                         | - | - | - | - |

| BITFIELD                            | BITS | DESCRIPTION   | DECODE                      |
|-------------------------------------|------|---|-----------------------------|
| config_sel_clock_out_use_external   | 7    | When 1, i_sel_clock_out is used to select output clock. Otherwise, internal registers are used. |                             |
| config_disable_div_out_exp          | 6    | Forces div_out_exp to 7, which disables the divider   | 0b0: Disable<br>0b1: Enable |
| config_use_internal_pll_mode_values | 5    | Bypasses internal pll_mode controls and uses config_reg values                                  | 0b0: Disable<br>0b1: Enable |
| config_use_internal_divider_values  | 4    | Forces all divider values to come from internal controls  | 0b0: Disable<br>0b1: Enable |

**DPLL 7 (0x1E07)**

| BIT         | 7               | 6                  | 5 | 4 | 3 | 2 | 1 | 0 |   |
|-------------|-----------------|--------------------|---|---|---|---|---|---|---|
| Field       | config_div_fb_L | config_div_in[4:0] |   |   |   | - | - | - | - |
| Reset       | 0b0             | 0b00001            |   |   |   | - | - | - |   |
| Access Type | Write, Read     | Write, Read        |   |   |   | - | - | - |   |

| BITFIELD        | BITS | DESCRIPTION  |
|-----------------|------|--|
| config_div_fb_L | 7    | Sets the feedback divider value when i_div_use_external = 0                                |
| config_div_in   | 6:2  | Sets the divide value of the input divider connected to i_clk_in, the main PLL clock input |

**DPLL 8 (0x1E08)**

| BIT         | 7                    | 6 | 5 | 4 | 3 | 2 | 1 | 0 |
|-------------|----------------------|---|---|---|---|---|---|---|
| Field       | config_div_fb_H[7:0] |   |   |   |   |   |   |   |
| Reset       | 0x14                 |   |   |   |   |   |   |   |
| Access Type | Write, Read          |   |   |   |   |   |   |   |

| BITFIELD        | BITS | DESCRIPTION   |
|-----------------|------|---|
| config_div_fb_H | 7:0  | Sets the feedback divider value when i_div_use_external = 0 |

**DPLL 10 (0x1E0A)**

| BIT         | 7 | 6                       | 5 | 4 | 3 | 2 | 1 | 0 |
|-------------|---|-------------------------|---|---|---|---|---|---|
| Field       | – | config_div_out_exp[2:0] |   |   | – | – | – | – |
| Reset       | – | 0b000                   |   |   | – | – | – | – |
| Access Type | – | Write, Read             |   |   | – | – | – | – |

| BITFIELD           | BITS | DESCRIPTION   |
|--------------------|------|---|
| config_div_out_exp | 6:4  | Sets the output exponential divider value when i_div_use_external = 0 |

**DPLL 0 (0x1F00)**

| BIT         | 7 | 6 | 5 | 4 | 3 | 2 | 1 | 0                 |
|-------------|---|---|---|---|---|---|---|-------------------|
| Field       | – | – | – | – | – | – | – | config_soft_rst_n |
| Reset       | – | – | – | – | – | – | – | 0b1               |
| Access Type | – | – | – | – | – | – | – | Write, Read       |

| BITFIELD          | BITS | DESCRIPTION   | DECODE                                       |
|-------------------|------|---|--|
| config_soft_rst_n | 0    | Setting this to 0 resets the PLL functional registers, config_regs are not reset. | 0b0: Reset asserted<br>0b1: Reset deasserted |

**DPLL 3 (0x1F03)**

| BIT | 7 | 6 | 5 | 4 | 3 | 2 | 1 | 0 |
|-----|---|---|---|---|---|---|---|---|
|-----|---|---|---|---|---|---|---|---|

|                        |                                       |                                |   |  |   |   |   |   |
|------------------------|---------------------------------------|--------------------------------|---|--|---|---|---|---|
| <b>Field</b>           | config_sel_clock_out_use_ext<br>ernal | config_disable_div_out_<br>exp | config_use_internal_pll_mode_<br>v<br>alues | config_use_internal_divider_<br>v<br>alues | - | - | - | - |
| <b>Reset</b>           | 0b1                                   | 0b0                            | 0b0   | 0b0  | - | - | - | - |
| <b>Access<br/>Type</b> | Write, Read                           | Write, Read                    | Write, Read                                 | Write, Read                                | - | - | - | - |

| <b>BITFIELD</b>                     | <b>BITS</b> | <b>DESCRIPTION</b>  | <b>DECODE</b>               |
|-------------------------------------|-------------|---|-----------------------------|
| config_sel_clock_out_use_external   | 7           | When 1, i_sel_clock_out is used to select output clock. Otherwise, internal registers are used. |                             |
| config_disable_div_out_exp          | 6           | Forces div_out_exp to 7, which disables the divider   | 0b0: Disable<br>0b1: Enable |
| config_use_internal_pll_mode_values | 5           | Bypasses internal pll_mode controls and uses config_reg values                                  | 0b0: Disable<br>0b1: Enable |
| config_use_internal_divider_values  | 4           | Forces all divider values to come from internal controls  | 0b0: Disable<br>0b1: Enable |

**DPLL 7 (0x1F07)**

| <b>BIT</b>         | <b>7</b>        | <b>6</b>           | <b>5</b> | <b>4</b> | <b>3</b> | <b>2</b> | <b>1</b> | <b>0</b> |
|--------------------|-----------------|--------------------|----------|----------|----------|----------|----------|----------|
| <b>Field</b>       | config_div_fb_L | config_div_in[4:0] |          |          |          |          | -        | -        |
| <b>Reset</b>       | 0b0             | 0b00001            |          |          |          |          | -        | -        |
| <b>Access Type</b> | Write, Read     | Write, Read        |          |          |          |          | -        | -        |

| <b>BITFIELD</b> | <b>BITS</b> | <b>DESCRIPTION</b>   |
|-----------------|-------------|--|
| config_div_fb_L | 7           | Sets the feedback divider value when i_div_use_external = 0                                |
| config_div_in   | 6:2         | Sets the divide value of the input divider connected to i_clk_in, the main PLL clock input |

**DPLL 8 (0x1F08)**

| <b>BIT</b>         | <b>7</b>             | <b>6</b> | <b>5</b> | <b>4</b> | <b>3</b> | <b>2</b> | <b>1</b> | <b>0</b> |
|--------------------|----------------------|----------|----------|----------|----------|----------|----------|----------|
| <b>Field</b>       | config_div_fb_H[7:0] |          |          |          |          |          |          |          |
| <b>Reset</b>       | 0x14                 |          |          |          |          |          |          |          |
| <b>Access Type</b> | Write, Read          |          |          |          |          |          |          |          |

| <b>BITFIELD</b> | <b>BITS</b> | <b>DESCRIPTION</b>  |
|-----------------|-------------|---|
| config_div_fb_H | 7:0         | Sets the feedback divider value when i_div_use_external = 0 |

**DPLL 10 (0x1F0A)**

| BIT         | 7 | 6                       | 5 | 4 | 3 | 2 | 1 | 0 |
|-------------|---|-------------------------|---|---|---|---|---|---|
| Field       | - | config_div_out_exp[2:0] |   |   | - | - | - | - |
| Reset       | - | 0b000                   |   |   | - | - | - | - |
| Access Type | - | Write, Read             |   |   | - | - | - | - |

| BITFIELD           | BITS | DESCRIPTION   |
|--------------------|------|---|
| config_div_out_exp | 6:4  | Sets the output exponential divider value when i_div_use_external = 0 |

**CLEAR STATS (0x2000)**

| BIT         | 7 | 6 | 5 | 4 | 3                      | 2                          | 1                      | 0                      |
|-------------|---|---|---|---|------------------------|----------------------------|------------------------|------------------------|
| Field       | - | - | - | - | CLEAR_BITS_CORRECTED   | CLEAR_BLOCKS_UNCORRECTABLE | CLEAR_BLOCKS_PROCESSED | CLEAR_ALL_STATS        |
| Reset       | - | - | - | - | 0b0                    | 0b0                        | 0b0                    | 0b0                    |
| Access Type | - | - | - | - | Write 1 to Clear, Read | Write 1 to Clear, Read     | Write 1 to Clear, Read | Write 1 to Clear, Read |

| BITFIELD                   | BITS | DESCRIPTION  | DECODE                          |
|----------------------------|------|--|---------------------------------|
| CLEAR_BITS_CORRECTED       | 3    | Clear counter for number of bits corrected by FEC    | 0b0: Do not clear<br>0b1: Clear |
| CLEAR_BLOCKS_UNCORRECTABLE | 2    | Clear counter for number of uncorrectable FEC blocks | 0b0: Do not clear<br>0b1: Clear |
| CLEAR_BLOCKS_PROCESSED     | 1    | Clear counter for number of FEC blocks processed     | 0b0: Do not clear<br>0b1: Clear |
| CLEAR_ALL_STATS            | 0    | Clear all FEC stats and counters                     | 0b0: Do not clear<br>0b1: Clear |

**STATS CONTROL (0x2001)**

| BIT         | 7 | 6 | 5 | 4 | 3 | 2 | 1 | 0            |
|-------------|---|---|---|---|---|---|---|--------------|
| Field       | - | - | - | - | - | - | - | STATS_ENABLE |
| Reset       | - | - | - | - | - | - | - | 0b0          |
| Access Type | - | - | - | - | - | - | - | Write, Read  |

| BITFIELD     | BITS | DESCRIPTION                            | DECODE                      |
|--------------|------|--|-----------------------------|
| STATS_ENABLE | 0    | Enable FEC stats collection for Link A | 0b0: Disable<br>0b1: Enable |

**CORRECTED THRESHOLD 0 (0x2008)**

| BIT         | 7                                   | 6 | 5 | 4 | 3 | 2 | 1 | 0 |
|-------------|-------------------------------------|---|---|---|---|---|---|---|
| Field       | BIT_ERRS_CORRECTED_THRESHOLD_0[7:0] |   |   |   |   |   |   |   |
| Reset       | 0x00                                |   |   |   |   |   |   |   |
| Access Type | Write, Read                         |   |   |   |   |   |   |   |

| BITFIELD                       | BITS | DESCRIPTION  |
|--------------------------------|------|--|
| BIT_ERRS_CORRECTED_THRESHOLD_0 | 7:0  | Threshold (decimal value) for number of bit errors seen before FEC error is asserted. Bits 7:0.<br>Set this to the maximum value so that the FEC error flag is not asserted and any correctable errors that occurred are successfully corrected. |

**CORRECTED THRESHOLD 1 (0x2009)**

| BIT         | 7                                   | 6 | 5 | 4 | 3 | 2 | 1 | 0 |
|-------------|-------------------------------------|---|---|---|---|---|---|---|
| Field       | BIT_ERRS_CORRECTED_THRESHOLD_1[7:0] |   |   |   |   |   |   |   |
| Reset       | 0x00                                |   |   |   |   |   |   |   |
| Access Type | Write, Read                         |   |   |   |   |   |   |   |

| BITFIELD                       | BITS | DESCRIPTION   |
|--------------------------------|------|---|
| BIT_ERRS_CORRECTED_THRESHOLD_1 | 7:0  | Threshold (decimal value) for number of bit errors seen before FEC error is asserted. Bits 15:8.<br>Set this to the maximum value so that the FEC error flag is not asserted and any correctable errors that occurred are successfully corrected. |

**CORRECTED THRESHOLD 2 (0x200A)**

| BIT         | 7                                   | 6 | 5 | 4 | 3 | 2 | 1 | 0 |
|-------------|-------------------------------------|---|---|---|---|---|---|---|
| Field       | BIT_ERRS_CORRECTED_THRESHOLD_2[7:0] |   |   |   |   |   |   |   |
| Reset       | 0x00                                |   |   |   |   |   |   |   |
| Access Type | Write, Read                         |   |   |   |   |   |   |   |

| BITFIELD                       | BITS | DESCRIPTION  |
|--------------------------------|------|--|
| BIT_ERRS_CORRECTED_THRESHOLD_2 | 7:0  | Threshold (decimal value) for number of bit errors seen before FEC error is asserted. Bits 23:16.<br>Set this to the maximum value so that the FEC error flag is not asserted and any correctable errors that occurred are successfully corrected. |

**CORRECTED\_THRESHOLD\_3 (0x200B)**

| BIT         | 7                                   | 6 | 5 | 4 | 3 | 2 | 1 | 0 |
|-------------|-------------------------------------|---|---|---|---|---|---|---|
| Field       | BIT_ERRS_CORRECTED_THRESHOLD_3[7:0] |   |   |   |   |   |   |   |
| Reset       | 0x00                                |   |   |   |   |   |   |   |
| Access Type | Write, Read                         |   |   |   |   |   |   |   |

| BITFIELD                       | BITS | DESCRIPTION  |
|--------------------------------|------|--|
| BIT_ERRS_CORRECTED_THRESHOLD_3 | 7:0  | Threshold (decimal value) for number of bit errors seen before FEC error is asserted. Bits 31:24.<br>Set this to the maximum value so that the FEC error flag is not asserted and any correctable errors that occurred are successfully corrected. |

**ERROR\_THRESHOLD\_0 (0x200C)**

| BIT         | 7                                  | 6 | 5 | 4 | 3 | 2 | 1 | 0 |
|-------------|------------------------------------|---|---|---|---|---|---|---|
| Field       | UNCORRECTED_ERROR_THRESHOLD_0[7:0] |   |   |   |   |   |   |   |
| Reset       | 0x00                               |   |   |   |   |   |   |   |
| Access Type | Write, Read                        |   |   |   |   |   |   |   |

| BITFIELD                      | BITS | DESCRIPTION   |
|-------------------------------|------|---|
| UNCORRECTED_ERROR_THRESHOLD_0 | 7:0  | Threshold (decimal value) for number of uncorrected blocks seen before FEC error is asserted. Bits 7:0. |

**ERROR\_THRESHOLD\_1 (0x200D)**

| BIT   | 7                                  | 6 | 5 | 4 | 3 | 2 | 1 | 0 |
|-------|------------------------------------|---|---|---|---|---|---|---|
| Field | UNCORRECTED_ERROR_THRESHOLD_1[7:0] |   |   |   |   |   |   |   |
| Reset | 0x00                               |   |   |   |   |   |   |   |

|                    |             |
|--------------------|-------------|
| <b>Access Type</b> | Write, Read |
|--------------------|-------------|

| <b>BITFIELD</b>               | <b>BITS</b> | <b>DESCRIPTION</b>   |
|-------------------------------|-------------|--|
| UNCORRECTED_ERROR_THRESHOLD_1 | 7:0         | Threshold (decimal value) for number of uncorrected blocks seen before FEC error is asserted. Bits 15:8. |

### ERROR\_THRESHOLD\_2 (0x200E)

| <b>BIT</b>         | <b>7</b>                           | <b>6</b> | <b>5</b> | <b>4</b> | <b>3</b> | <b>2</b> | <b>1</b> | <b>0</b> |
|--------------------|------------------------------------|----------|----------|----------|----------|----------|----------|----------|
| <b>Field</b>       | UNCORRECTED_ERROR_THRESHOLD_2[7:0] |          |          |          |          |          |          |          |
| <b>Reset</b>       | 0x00                               |          |          |          |          |          |          |          |
| <b>Access Type</b> | Write, Read                        |          |          |          |          |          |          |          |

| <b>BITFIELD</b>               | <b>BITS</b> | <b>DESCRIPTION</b>  |
|-------------------------------|-------------|---|
| UNCORRECTED_ERROR_THRESHOLD_2 | 7:0         | Threshold (decimal value) for number of uncorrected blocks seen before FEC error is asserted. Bits 23:16. |

### ERROR\_THRESHOLD\_3 (0x200F)

| <b>BIT</b>         | <b>7</b>                           | <b>6</b> | <b>5</b> | <b>4</b> | <b>3</b> | <b>2</b> | <b>1</b> | <b>0</b> |
|--------------------|------------------------------------|----------|----------|----------|----------|----------|----------|----------|
| <b>Field</b>       | UNCORRECTED_ERROR_THRESHOLD_3[7:0] |          |          |          |          |          |          |          |
| <b>Reset</b>       | 0x00                               |          |          |          |          |          |          |          |
| <b>Access Type</b> | Write, Read                        |          |          |          |          |          |          |          |

| <b>BITFIELD</b>               | <b>BITS</b> | <b>DESCRIPTION</b>  |
|-------------------------------|-------------|---|
| UNCORRECTED_ERROR_THRESHOLD_3 | 7:0         | Threshold (decimal value) for number of uncorrected blocks seen before FEC error is asserted. Bits 31:24. |

### BLOCKS\_UNCORRECTABLE\_0 (0x2020)

| <b>BIT</b>         | <b>7</b>                    | <b>6</b> | <b>5</b> | <b>4</b> | <b>3</b> | <b>2</b> | <b>1</b> | <b>0</b> |
|--------------------|-----------------------------|----------|----------|----------|----------|----------|----------|----------|
| <b>Field</b>       | UNCORRECTABLE_BLOCKS_0[7:0] |          |          |          |          |          |          |          |
| <b>Reset</b>       | 0x00                        |          |          |          |          |          |          |          |
| <b>Access Type</b> | Read Only                   |          |          |          |          |          |          |          |

| BITFIELD               | BITS | DESCRIPTION                               |
|------------------------|------|---|
| UNCORRECTABLE_BLOCKS_0 | 7:0  | Number of uncorrectable blocks. Bits 7:0. |

**BLOCKS UNCORRECTABLE 1 (0x2021)**

| BIT         | 7                           | 6 | 5 | 4 | 3 | 2 | 1 | 0 |
|-------------|-----------------------------|---|---|---|---|---|---|---|
| Field       | UNCORRECTABLE_BLOCKS_1[7:0] |   |   |   |   |   |   |   |
| Reset       | 0x00                        |   |   |   |   |   |   |   |
| Access Type | Read Only                   |   |   |   |   |   |   |   |

| BITFIELD               | BITS | DESCRIPTION                                |
|------------------------|------|--|
| UNCORRECTABLE_BLOCKS_1 | 7:0  | Number of uncorrectable blocks. Bits 15:8. |

**BLOCKS UNCORRECTABLE 2 (0x2022)**

| BIT         | 7                           | 6 | 5 | 4 | 3 | 2 | 1 | 0 |
|-------------|-----------------------------|---|---|---|---|---|---|---|
| Field       | UNCORRECTABLE_BLOCKS_2[7:0] |   |   |   |   |   |   |   |
| Reset       | 0x00                        |   |   |   |   |   |   |   |
| Access Type | Read Only                   |   |   |   |   |   |   |   |

| BITFIELD               | BITS | DESCRIPTION                                 |
|------------------------|------|---|
| UNCORRECTABLE_BLOCKS_2 | 7:0  | Number of uncorrectable blocks. Bits 23:16. |

**BLOCKS UNCORRECTABLE 3 (0x2023)**

| BIT         | 7                           | 6 | 5 | 4 | 3 | 2 | 1 | 0 |
|-------------|-----------------------------|---|---|---|---|---|---|---|
| Field       | UNCORRECTABLE_BLOCKS_3[7:0] |   |   |   |   |   |   |   |
| Reset       | 0x00                        |   |   |   |   |   |   |   |
| Access Type | Read Only                   |   |   |   |   |   |   |   |

| BITFIELD               | BITS | DESCRIPTION                                 |
|------------------------|------|---|
| UNCORRECTABLE_BLOCKS_3 | 7:0  | Number of uncorrectable blocks. Bits 31:24. |

**BITS CORRECTED 0 (0x2024)**

| BIT         | 7                         | 6 | 5 | 4 | 3 | 2 | 1 | 0 |
|-------------|---------------------------|---|---|---|---|---|---|---|
| Field       | BIT_ERRS_CORRECTED_0[7:0] |   |   |   |   |   |   |   |
| Reset       | 0x00                      |   |   |   |   |   |   |   |
| Access Type | Read Only                 |   |   |   |   |   |   |   |

| BITFIELD             | BITS | DESCRIPTION                               |
|----------------------|------|---|
| BIT_ERRS_CORRECTED_0 | 7:0  | Number of bit errors corrected. Bits 7:0. |

**BITS CORRECTED 1 (0x2025)**

| BIT         | 7                         | 6 | 5 | 4 | 3 | 2 | 1 | 0 |
|-------------|---------------------------|---|---|---|---|---|---|---|
| Field       | BIT_ERRS_CORRECTED_1[7:0] |   |   |   |   |   |   |   |
| Reset       | 0x00                      |   |   |   |   |   |   |   |
| Access Type | Read Only                 |   |   |   |   |   |   |   |

| BITFIELD             | BITS | DESCRIPTION                                |
|----------------------|------|--|
| BIT_ERRS_CORRECTED_1 | 7:0  | Number of bit errors corrected. Bits 15:8. |

**BITS CORRECTED 2 (0x2026)**

| BIT         | 7                         | 6 | 5 | 4 | 3 | 2 | 1 | 0 |
|-------------|---------------------------|---|---|---|---|---|---|---|
| Field       | BIT_ERRS_CORRECTED_2[7:0] |   |   |   |   |   |   |   |
| Reset       | 0x00                      |   |   |   |   |   |   |   |
| Access Type | Read Only                 |   |   |   |   |   |   |   |

| BITFIELD             | BITS | DESCRIPTION                                 |
|----------------------|------|---|
| BIT_ERRS_CORRECTED_2 | 7:0  | Number of bit errors corrected. Bits 23:16. |

**BITS CORRECTED 3 (0x2027)**

| BIT   | 7                         | 6 | 5 | 4 | 3 | 2 | 1 | 0 |
|-------|---------------------------|---|---|---|---|---|---|---|
| Field | BIT_ERRS_CORRECTED_3[7:0] |   |   |   |   |   |   |   |

|                    |           |
|--------------------|-----------|
| <b>Reset</b>       | 0x00      |
| <b>Access Type</b> | Read Only |

| BITFIELD             | BITS | DESCRIPTION                                 |
|----------------------|------|---|
| BIT_ERRS_CORRECTED_3 | 7:0  | Number of bit errors corrected. Bits 31:24. |

**BLOCKS PROCESSED 0 (0x2028)**

| BIT                | 7                       | 6 | 5 | 4 | 3 | 2 | 1 | 0 |
|--------------------|-------------------------|---|---|---|---|---|---|---|
| <b>Field</b>       | BLOCKS_PROCESSED_0[7:0] |   |   |   |   |   |   |   |
| <b>Reset</b>       | 0x00                    |   |   |   |   |   |   |   |
| <b>Access Type</b> | Read Only               |   |   |   |   |   |   |   |

| BITFIELD           | BITS | DESCRIPTION                                   |
|--------------------|------|---|
| BLOCKS_PROCESSED_0 | 7:0  | Number of 120-bit blocks processed. Bits 7:0. |

**BLOCKS PROCESSED 1 (0x2029)**

| BIT                | 7                       | 6 | 5 | 4 | 3 | 2 | 1 | 0 |
|--------------------|-------------------------|---|---|---|---|---|---|---|
| <b>Field</b>       | BLOCKS_PROCESSED_1[7:0] |   |   |   |   |   |   |   |
| <b>Reset</b>       | 0x00                    |   |   |   |   |   |   |   |
| <b>Access Type</b> | Read Only               |   |   |   |   |   |   |   |

| BITFIELD           | BITS | DESCRIPTION                                    |
|--------------------|------|--|
| BLOCKS_PROCESSED_1 | 7:0  | Number of 120-bit blocks processed. Bits 15:8. |

**BLOCKS PROCESSED 2 (0x202A)**

| BIT                | 7                       | 6 | 5 | 4 | 3 | 2 | 1 | 0 |
|--------------------|-------------------------|---|---|---|---|---|---|---|
| <b>Field</b>       | BLOCKS_PROCESSED_2[7:0] |   |   |   |   |   |   |   |
| <b>Reset</b>       | 0x00                    |   |   |   |   |   |   |   |
| <b>Access Type</b> | Read Only               |   |   |   |   |   |   |   |

| BITFIELD           | BITS | DESCRIPTION                                     |
|--------------------|------|---|
| BLOCKS_PROCESSED_2 | 7:0  | Number of 120-bit blocks processed. Bits 23:16. |

**BLOCKS PROCESSED 3 (0x202B)**

| BIT         | 7                       | 6 | 5 | 4 | 3 | 2 | 1 | 0 |
|-------------|-------------------------|---|---|---|---|---|---|---|
| Field       | BLOCKS_PROCESSED_3[7:0] |   |   |   |   |   |   |   |
| Reset       | 0x00                    |   |   |   |   |   |   |   |
| Access Type | Read Only               |   |   |   |   |   |   |   |

| BITFIELD           | BITS | DESCRIPTION                                     |
|--------------------|------|---|
| BLOCKS_PROCESSED_3 | 7:0  | Number of 120-bit blocks processed. Bits 31:24. |

**CLEAR STATS (0x2100)**

| BIT         | 7 | 6 | 5 | 4 | 3                      | 2                            | 1                        | 0                      |
|-------------|---|---|---|---|------------------------|------------------------------|--------------------------|------------------------|
| Field       | - | - | - | - | CLEAR_BITS_CORRECTED_B | CLEAR_BLOCKS_UNCORRECTABLE_B | CLEAR_BLOCKS_PROCESSED_B | CLEAR_ALL_STATS_B      |
| Reset       | - | - | - | - | 0b0                    | 0b0                          | 0b0                      | 0b0                    |
| Access Type | - | - | - | - | Write 1 to Clear, Read | Write 1 to Clear, Read       | Write 1 to Clear, Read   | Write 1 to Clear, Read |

| BITFIELD                     | BITS | DESCRIPTION  | DECODE                          |
|------------------------------|------|--|---------------------------------|
| CLEAR_BITS_CORRECTED_B       | 3    | Clear counter for number of bits corrected by FEC    | 0b0: Do not clear<br>0b1: Clear |
| CLEAR_BLOCKS_UNCORRECTABLE_B | 2    | Clear counter for number of uncorrectable FEC blocks | 0b0: Do not clear<br>0b1: Clear |
| CLEAR_BLOCKS_PROCESSED_B     | 1    | Clear counter for number of FEC blocks processed     | 0b0: Do not clear<br>0b1: Clear |
| CLEAR_ALL_STATS_B            | 0    | Clear all FEC stats and counters                     | 0b0: Do not clear<br>0b1: Clear |

**STATS CONTROL (0x2101)**

| BIT | 7 | 6 | 5 | 4 | 3 | 2 | 1 | 0 |
|-----|---|---|---|---|---|---|---|---|
|-----|---|---|---|---|---|---|---|---|

|             |   |   |   |   |   |   |   |                |
|-------------|---|---|---|---|---|---|---|----------------|
| Field       | - | - | - | - | - | - | - | STATS_ENABLE_B |
| Reset       | - | - | - | - | - | - | - | 0b0            |
| Access Type | - | - | - | - | - | - | - | Write, Read    |

| BITFIELD       | BITS | DESCRIPTION                            | DECODE                      |
|----------------|------|--|-----------------------------|
| STATS_ENABLE_B | 0    | Enable FEC stats collection for Link B | 0b0: Disable<br>0b1: Enable |

**CORRECTED THRESHOLD 0 (0x2108)**

|             |                                       |   |   |   |   |   |   |   |
|-------------|---------------------------------------|---|---|---|---|---|---|---|
| BIT         | 7                                     | 6 | 5 | 4 | 3 | 2 | 1 | 0 |
| Field       | BIT_ERRS_CORRECTED_THRESHOLD_0_B[7:0] |   |   |   |   |   |   |   |
| Reset       | 0x00                                  |   |   |   |   |   |   |   |
| Access Type | Write, Read                           |   |   |   |   |   |   |   |

| BITFIELD                         | BITS | DESCRIPTION  |
|----------------------------------|------|--|
| BIT_ERRS_CORRECTED_THRESHOLD_0_B | 7:0  | Threshold (decimal value) for number of bit errors seen before FEC error is asserted. Bits 7:0.<br>Set this to the maximum value so that the FEC error flag is not asserted and any correctable errors that occurred are successfully corrected. |

**CORRECTED THRESHOLD 1 (0x2109)**

|             |                                       |   |   |   |   |   |   |   |
|-------------|---------------------------------------|---|---|---|---|---|---|---|
| BIT         | 7                                     | 6 | 5 | 4 | 3 | 2 | 1 | 0 |
| Field       | BIT_ERRS_CORRECTED_THRESHOLD_1_B[7:0] |   |   |   |   |   |   |   |
| Reset       | 0x00                                  |   |   |   |   |   |   |   |
| Access Type | Write, Read                           |   |   |   |   |   |   |   |

| BITFIELD                         | BITS | DESCRIPTION  |
|----------------------------------|------|--|
| BIT_ERRS_CORRECTED_THRESHOLD_1_B | 7:0  | Threshold (decimal value) for number of bit errors seen before FEC error is asserted. Bits 15:8.<br>Set this to the maximum value so that the FEC error flag is not asserted and any correctable errors that occurred are successfully corrected.. |

**CORRECTED THRESHOLD 2 (0x210A)**

| BIT         | 7                                     | 6 | 5 | 4 | 3 | 2 | 1 | 0 |
|-------------|---------------------------------------|---|---|---|---|---|---|---|
| Field       | BIT_ERRS_CORRECTED_THRESHOLD_2_B[7:0] |   |   |   |   |   |   |   |
| Reset       | 0x00                                  |   |   |   |   |   |   |   |
| Access Type | Write, Read                           |   |   |   |   |   |   |   |

| BITFIELD                         | BITS | DESCRIPTION  |
|----------------------------------|------|--|
| BIT_ERRS_CORRECTED_THRESHOLD_2_B | 7:0  | Threshold (decimal value) for number of bit errors seen before FEC error is asserted. Bits 23:16.<br>Set this to the maximum value so that the FEC error flag is not asserted and any correctable errors that occurred are successfully corrected. |

**CORRECTED THRESHOLD 3 (0x210B)**

| BIT         | 7                                     | 6 | 5 | 4 | 3 | 2 | 1 | 0 |
|-------------|---------------------------------------|---|---|---|---|---|---|---|
| Field       | BIT_ERRS_CORRECTED_THRESHOLD_3_B[7:0] |   |   |   |   |   |   |   |
| Reset       | 0x00                                  |   |   |   |   |   |   |   |
| Access Type | Write, Read                           |   |   |   |   |   |   |   |

| BITFIELD                         | BITS | DESCRIPTION  |
|----------------------------------|------|--|
| BIT_ERRS_CORRECTED_THRESHOLD_3_B | 7:0  | Threshold (decimal value) for number of bit errors seen before FEC error is asserted. Bits 31:24.<br>Set this to the maximum value so that the FEC error flag is not asserted and any correctable errors that occurred are successfully corrected. |

**ERROR THRESHOLD 0 (0x210C)**

| BIT         | 7                                    | 6 | 5 | 4 | 3 | 2 | 1 | 0 |
|-------------|--------------------------------------|---|---|---|---|---|---|---|
| Field       | UNCORRECTED_ERROR_THRESHOLD_0_B[7:0] |   |   |   |   |   |   |   |
| Reset       | 0x00                                 |   |   |   |   |   |   |   |
| Access Type | Write, Read                          |   |   |   |   |   |   |   |

| BITFIELD                        | BITS | DESCRIPTION   |
|---------------------------------|------|---|
| UNCORRECTED_ERROR_THRESHOLD_0_B | 7:0  | Threshold (decimal value) for number of uncorrected blocks seen before FEC error is asserted. Bits 7:0. |

**ERROR THRESHOLD 1 (0x210D)**

| BIT         | 7                                    | 6 | 5 | 4 | 3 | 2 | 1 | 0 |
|-------------|--------------------------------------|---|---|---|---|---|---|---|
| Field       | UNCORRECTED_ERROR_THRESHOLD_1_B[7:0] |   |   |   |   |   |   |   |
| Reset       | 0x00                                 |   |   |   |   |   |   |   |
| Access Type | Write, Read                          |   |   |   |   |   |   |   |

| BITFIELD                        | BITS | DESCRIPTION  |
|---------------------------------|------|--|
| UNCORRECTED_ERROR_THRESHOLD_1_B | 7:0  | Threshold (decimal value) for number of uncorrected blocks seen before FEC error is asserted. Bits 15:8. |

**ERROR THRESHOLD 2 (0x210E)**

| BIT         | 7                                    | 6 | 5 | 4 | 3 | 2 | 1 | 0 |
|-------------|--------------------------------------|---|---|---|---|---|---|---|
| Field       | UNCORRECTED_ERROR_THRESHOLD_2_B[7:0] |   |   |   |   |   |   |   |
| Reset       | 0x00                                 |   |   |   |   |   |   |   |
| Access Type | Write, Read                          |   |   |   |   |   |   |   |

| BITFIELD                        | BITS | DESCRIPTION   |
|---------------------------------|------|---|
| UNCORRECTED_ERROR_THRESHOLD_2_B | 7:0  | Threshold (decimal value) for number of uncorrected blocks seen before FEC error is asserted. Bits 23:16. |

**ERROR THRESHOLD 3 (0x210F)**

| BIT         | 7                                    | 6 | 5 | 4 | 3 | 2 | 1 | 0 |
|-------------|--------------------------------------|---|---|---|---|---|---|---|
| Field       | UNCORRECTED_ERROR_THRESHOLD_3_B[7:0] |   |   |   |   |   |   |   |
| Reset       | 0x00                                 |   |   |   |   |   |   |   |
| Access Type | Write, Read                          |   |   |   |   |   |   |   |

| BITFIELD                        | BITS | DESCRIPTION   |
|---------------------------------|------|---|
| UNCORRECTED_ERROR_THRESHOLD_3_B | 7:0  | Threshold (decimal value) for number of uncorrected blocks seen before FEC error is asserted. Bits 31:24. |

**BLOCKS UNCORRECTABLE 0 (0x2120)**

| BIT         | 7                             | 6 | 5 | 4 | 3 | 2 | 1 | 0 |
|-------------|-------------------------------|---|---|---|---|---|---|---|
| Field       | UNCORRECTABLE_BLOCKS_0_B[7:0] |   |   |   |   |   |   |   |
| Reset       | 0x00                          |   |   |   |   |   |   |   |
| Access Type | Read Only                     |   |   |   |   |   |   |   |

| BITFIELD                 | BITS | DESCRIPTION                               |
|--------------------------|------|---|
| UNCORRECTABLE_BLOCKS_0_B | 7:0  | Number of uncorrectable blocks. Bits 7:0. |

**BLOCKS UNCORRECTABLE 1 (0x2121)**

| BIT         | 7                             | 6 | 5 | 4 | 3 | 2 | 1 | 0 |
|-------------|-------------------------------|---|---|---|---|---|---|---|
| Field       | UNCORRECTABLE_BLOCKS_1_B[7:0] |   |   |   |   |   |   |   |
| Reset       | 0x00                          |   |   |   |   |   |   |   |
| Access Type | Read Only                     |   |   |   |   |   |   |   |

| BITFIELD                 | BITS | DESCRIPTION                                |
|--------------------------|------|--|
| UNCORRECTABLE_BLOCKS_1_B | 7:0  | Number of uncorrectable blocks. Bits 15:8. |

**BLOCKS UNCORRECTABLE 2 (0x2122)**

| BIT         | 7                             | 6 | 5 | 4 | 3 | 2 | 1 | 0 |
|-------------|-------------------------------|---|---|---|---|---|---|---|
| Field       | UNCORRECTABLE_BLOCKS_2_B[7:0] |   |   |   |   |   |   |   |
| Reset       | 0x00                          |   |   |   |   |   |   |   |
| Access Type | Read Only                     |   |   |   |   |   |   |   |

| BITFIELD                 | BITS | DESCRIPTION                                 |
|--------------------------|------|---|
| UNCORRECTABLE_BLOCKS_2_B | 7:0  | Number of uncorrectable blocks. Bits 23:16. |

**BLOCKS UNCORRECTABLE 3 (0x2123)**

| BIT   | 7                             | 6 | 5 | 4 | 3 | 2 | 1 | 0 |
|-------|-------------------------------|---|---|---|---|---|---|---|
| Field | UNCORRECTABLE_BLOCKS_3_B[7:0] |   |   |   |   |   |   |   |

|                    |           |
|--------------------|-----------|
| <b>Reset</b>       | 0x00      |
| <b>Access Type</b> | Read Only |

| BITFIELD                 | BITS | DESCRIPTION                                 |
|--------------------------|------|---|
| UNCORRECTABLE_BLOCKS_3_B | 7:0  | Number of uncorrectable blocks. Bits 31:24. |

**BITS CORRECTED 0 (0x2124)**

| BIT                | 7                           | 6 | 5 | 4 | 3 | 2 | 1 | 0 |
|--------------------|-----------------------------|---|---|---|---|---|---|---|
| <b>Field</b>       | BIT_ERRS_CORRECTED_0_B[7:0] |   |   |   |   |   |   |   |
| <b>Reset</b>       | 0x00                        |   |   |   |   |   |   |   |
| <b>Access Type</b> | Read Only                   |   |   |   |   |   |   |   |

| BITFIELD               | BITS | DESCRIPTION                               |
|------------------------|------|---|
| BIT_ERRS_CORRECTED_0_B | 7:0  | Number of bit errors corrected. Bits 7:0. |

**BITS CORRECTED 1 (0x2125)**

| BIT                | 7                           | 6 | 5 | 4 | 3 | 2 | 1 | 0 |
|--------------------|-----------------------------|---|---|---|---|---|---|---|
| <b>Field</b>       | BIT_ERRS_CORRECTED_1_B[7:0] |   |   |   |   |   |   |   |
| <b>Reset</b>       | 0x00                        |   |   |   |   |   |   |   |
| <b>Access Type</b> | Read Only                   |   |   |   |   |   |   |   |

| BITFIELD               | BITS | DESCRIPTION                                |
|------------------------|------|--|
| BIT_ERRS_CORRECTED_1_B | 7:0  | Number of bit errors corrected. Bits 15:8. |

**BITS CORRECTED 2 (0x2126)**

| BIT                | 7                           | 6 | 5 | 4 | 3 | 2 | 1 | 0 |
|--------------------|-----------------------------|---|---|---|---|---|---|---|
| <b>Field</b>       | BIT_ERRS_CORRECTED_2_B[7:0] |   |   |   |   |   |   |   |
| <b>Reset</b>       | 0x00                        |   |   |   |   |   |   |   |
| <b>Access Type</b> | Read Only                   |   |   |   |   |   |   |   |

| BITFIELD               | BITS | DESCRIPTION                                 |
|------------------------|------|---|
| BIT_ERRS_CORRECTED_2_B | 7:0  | Number of bit errors corrected. Bits 23:16. |

**BITS CORRECTED 3 (0x2127)**

| BIT         | 7                           | 6 | 5 | 4 | 3 | 2 | 1 | 0 |
|-------------|-----------------------------|---|---|---|---|---|---|---|
| Field       | BIT_ERRS_CORRECTED_3_B[7:0] |   |   |   |   |   |   |   |
| Reset       | 0x00                        |   |   |   |   |   |   |   |
| Access Type | Read Only                   |   |   |   |   |   |   |   |

| BITFIELD               | BITS | DESCRIPTION                                 |
|------------------------|------|---|
| BIT_ERRS_CORRECTED_3_B | 7:0  | Number of bit errors corrected. Bits 31:24. |

**BLOCKS PROCESSED 0 (0x2128)**

| BIT         | 7                         | 6 | 5 | 4 | 3 | 2 | 1 | 0 |
|-------------|---------------------------|---|---|---|---|---|---|---|
| Field       | BLOCKS_PROCESSED_0_B[7:0] |   |   |   |   |   |   |   |
| Reset       | 0x00                      |   |   |   |   |   |   |   |
| Access Type | Read Only                 |   |   |   |   |   |   |   |

| BITFIELD             | BITS | DESCRIPTION                                   |
|----------------------|------|---|
| BLOCKS_PROCESSED_0_B | 7:0  | Number of 120-bit blocks processed. Bits 7:0. |

**BLOCKS PROCESSED 1 (0x2129)**

| BIT         | 7                         | 6 | 5 | 4 | 3 | 2 | 1 | 0 |
|-------------|---------------------------|---|---|---|---|---|---|---|
| Field       | BLOCKS_PROCESSED_1_B[7:0] |   |   |   |   |   |   |   |
| Reset       | 0x00                      |   |   |   |   |   |   |   |
| Access Type | Read Only                 |   |   |   |   |   |   |   |

| BITFIELD             | BITS | DESCRIPTION                                    |
|----------------------|------|--|
| BLOCKS_PROCESSED_1_B | 7:0  | Number of 120-bit blocks processed. Bits 15:8. |

**BLOCKS PROCESSED 2 (0x212A)**

| BIT         | 7                         | 6 | 5 | 4 | 3 | 2 | 1 | 0 |
|-------------|---------------------------|---|---|---|---|---|---|---|
| Field       | BLOCKS_PROCESSED_2_B[7:0] |   |   |   |   |   |   |   |
| Reset       | 0x00                      |   |   |   |   |   |   |   |
| Access Type | Read Only                 |   |   |   |   |   |   |   |

| BITFIELD             | BITS | DESCRIPTION                                     |
|----------------------|------|---|
| BLOCKS_PROCESSED_2_B | 7:0  | Number of 120-bit blocks processed. Bits 23:16. |

**BLOCKS PROCESSED 3 (0x212B)**

| BIT         | 7                         | 6 | 5 | 4 | 3 | 2 | 1 | 0 |
|-------------|---------------------------|---|---|---|---|---|---|---|
| Field       | BLOCKS_PROCESSED_3_B[7:0] |   |   |   |   |   |   |   |
| Reset       | 0x00                      |   |   |   |   |   |   |   |
| Access Type | Read Only                 |   |   |   |   |   |   |   |

| BITFIELD             | BITS | DESCRIPTION                                     |
|----------------------|------|---|
| BLOCKS_PROCESSED_3_B | 7:0  | Number of 120-bit blocks processed. Bits 31:24. |

**REGCRC0 (0x3000)**

| BIT         | 7 | 6 | 5 | 4               | 3              | 2                | 1           | 0                      |
|-------------|---|---|---|-----------------|----------------|------------------|-------------|------------------------|
| Field       | – | – | – | GEN_ROLLING_CRC | I2C_WR_COMPUTE | PERIODIC_COMPUTE | CHECK_CRC   | RESET_CRC              |
| Reset       | – | – | – | 0b0             | 0b0            | 0b0              | 0b0         | 0b0                    |
| Access Type | – | – | – | Write, Read     | Write, Read    | Write, Read      | Write, Read | Write Clears All, Read |

| BITFIELD         | BITS | DESCRIPTION   | DECODE                      |
|------------------|------|---|-----------------------------|
| GEN_ROLLING_CRC  | 4    | Calculate CRC using additional 2-bit counter, so CRC value cycles every four invocations. | 0b0: Disable<br>0b1: Enable |
| I2C_WR_COMPUTE   | 3    | Execute CRC computation after every I <sup>2</sup> C register write.                      | 0b0: Disable<br>0b1: Enable |
| PERIODIC_COMPUTE | 2    | Perform CRC check on a periodic basis, based on CRC_PERIOD value.                         | 0b0: Disable<br>0b1: Enable |

| BITFIELD  | BITS | DESCRIPTION   | DECODE                                       |
|-----------|------|---|--|
| CHECK_CRC | 1    | Upon calculation of CRC, compare with previous calculation, except on first time through.<br><br>On mismatch, issue ERRB. | 0b0: Disable<br>0b1: Enable                  |
| RESET_CRC | 0    | Reset CRC value to 16'FFFF.   | 0b0: Reset deasserted<br>0b1: Reset asserted |

**REGCRC1 (0x3001)**

| BIT         | 7               | 6 | 5 | 4 | 3 | 2 | 1 | 0 |
|-------------|-----------------|---|---|---|---|---|---|---|
| Field       | CRC_PERIOD[7:0] |   |   |   |   |   |   |   |
| Reset       | 0x00            |   |   |   |   |   |   |   |
| Access Type | Write, Read     |   |   |   |   |   |   |   |

| BITFIELD   | BITS | DESCRIPTION   |
|------------|------|---|
| CRC_PERIOD | 7:0  | Period for CRC recomputation.<br>This allows to vary the CRC computation time.<br>Period = (value + 1) x 2ms<br><br>0000_0000 - 2ms<br>0000_0001 - 4ms<br>... |

**REGCRC2 (0x3002)**

| BIT         | 7               | 6 | 5 | 4 | 3 | 2 | 1 | 0 |
|-------------|-----------------|---|---|---|---|---|---|---|
| Field       | REGCRC_LSB[7:0] |   |   |   |   |   |   |   |
| Reset       | 0x00            |   |   |   |   |   |   |   |
| Access Type | Read Only       |   |   |   |   |   |   |   |

| BITFIELD   | BITS | DESCRIPTION    |
|------------|------|----------------|
| REGCRC_LSB | 7:0  | CRC result LSB |

**REGCRC3 (0x3003)**

| BIT   | 7               | 6 | 5 | 4 | 3 | 2 | 1 | 0 |
|-------|-----------------|---|---|---|---|---|---|---|
| Field | REGCRC_MSB[7:0] |   |   |   |   |   |   |   |

|                    |           |
|--------------------|-----------|
| <b>Reset</b>       | 0x00      |
| <b>Access Type</b> | Read Only |

| BITFIELD   | BITS | DESCRIPTION    |
|------------|------|----------------|
| REGCRC_MSB | 7:0  | CRC result MSB |

### I2C UART CRC0 (0x3008)

| BIT                | 7 | 6 | 5 | 4 | 3 | 2 | 1 | 0                      |
|--------------------|---|---|---|---|---|---|---|------------------------|
| <b>Field</b>       | – | – | – | – | – | – | – | RESET_MSGCNTR          |
| <b>Reset</b>       | – | – | – | – | – | – | – | 0b0                    |
| <b>Access Type</b> | – | – | – | – | – | – | – | Write Clears All, Read |

| BITFIELD      | BITS | DESCRIPTION                      | DECODE                                       |
|---------------|------|----------------------------------|--|
| RESET_MSGCNTR | 0    | Reset Message Counter Value to 0 | 0b0: Reset deasserted<br>0b1: Reset asserted |

### I2C UART CRC1 (0x3009)

| BIT                | 7                    | 6 | 5 | 4                | 3 | 2 | 1                      | 0                      |
|--------------------|----------------------|---|---|------------------|---|---|------------------------|------------------------|
| <b>Field</b>       | MSGCNTR_ERR_THR[2:0] |   |   | CRC_ERR_THR[2:0] |   |   | RESET_MSGCNTR_ERR_CNT  | RESET_CRC_ERR_CNT      |
| <b>Reset</b>       | 0b000                |   |   | 0b000            |   |   | 0b0                    | 0b0                    |
| <b>Access Type</b> | Write, Read          |   |   | Write, Read      |   |   | Write Clears All, Read | Write Clears All, Read |

| BITFIELD        | BITS | DESCRIPTION   | DECODE  |
|-----------------|------|---|---|
| MSGCNTR_ERR_THR | 7:5  | I <sup>2</sup> C/UART CRC error reporting threshold <ul style="list-style-type: none"> <li>I2C_UART_CRC_ERR_INT is asserted when CRC_ERR_CNT ≥ CRC_ERR_THR</li> </ul> | 0b000: 1<br>0b001: 2<br>0b010: 4<br>0b011: 8<br>0b101: 16<br>0b101: 32<br>0b110: 64<br>0b111: 128 |
| CRC_ERR_THR     | 4:2  | I <sup>2</sup> C/UART CRC error reporting threshold <ul style="list-style-type: none"> <li>I2C_UART_CRC_ERR_INT is asserted when CRC_ERR_CNT ≥ CRC_ERR_THR</li> </ul> | 0b000: 1<br>0b001: 2<br>0b010: 4<br>0b011: 8<br>0b101: 16<br>0b101: 32<br>0b110: 64<br>0b111: 128 |

| BITFIELD              | BITS | DESCRIPTION                            | DECODE                                       |
|-----------------------|------|--|--|
| RESET_MSGCNTR_ERR_CNT | 1    | Reset Message Counter Error Count to 0 | 0b0: Reset deasserted<br>0b1: Reset asserted |
| RESET_CRC_ERR_CNT     | 0    | Reset CRC Error Count to 0             | 0b0: Reset deasserted<br>0b1: Reset asserted |

**I2C UART CRC2 (0x300A)**

| BIT         | 7            | 6 | 5 | 4 | 3 | 2 | 1 | 0 |
|-------------|--------------|---|---|---|---|---|---|---|
| Field       | CRC_VAL[7:0] |   |   |   |   |   |   |   |
| Reset       | 0x00         |   |   |   |   |   |   |   |
| Access Type | Read Only    |   |   |   |   |   |   |   |

| BITFIELD | BITS | DESCRIPTION   |
|----------|------|---|
| CRC_VAL  | 7:0  | Calculated CRC value for the last write transaction |

**I2C UART CRC3 (0x300B)**

| BIT         | 7                | 6 | 5 | 4 | 3 | 2 | 1 | 0 |
|-------------|------------------|---|---|---|---|---|---|---|
| Field       | MSGCNTR_LSB[7:0] |   |   |   |   |   |   |   |
| Reset       | 0x00             |   |   |   |   |   |   |   |
| Access Type | Read Only        |   |   |   |   |   |   |   |

| BITFIELD    | BITS | DESCRIPTION                               |
|-------------|------|---|
| MSGCNTR_LSB | 7:0  | Bits 7:0 of current Message Counter value |

**I2C UART CRC4 (0x300C)**

| BIT         | 7                | 6 | 5 | 4 | 3 | 2 | 1 | 0 |
|-------------|------------------|---|---|---|---|---|---|---|
| Field       | MSGCNTR_MSB[7:0] |   |   |   |   |   |   |   |
| Reset       | 0x00             |   |   |   |   |   |   |   |
| Access Type | Read Only        |   |   |   |   |   |   |   |

| BITFIELD    | BITS | DESCRIPTION                               |
|-------------|------|---|
| MSGCNTR_MSB | 7:0  | Bits 7:0 of current Message Counter value |

**I2C UART CRC5 (0x300D)**

| BIT         | 7                | 6 | 5 | 4 | 3 | 2 | 1 | 0 |
|-------------|------------------|---|---|---|---|---|---|---|
| Field       | CRC_ERR_CNT[7:0] |   |   |   |   |   |   |   |
| Reset       | 0x00             |   |   |   |   |   |   |   |
| Access Type | Read Only        |   |   |   |   |   |   |   |

| BITFIELD    | BITS | DESCRIPTION                   |
|-------------|------|-------------------------------|
| CRC_ERR_CNT | 7:0  | Number of CRC errors observed |

**I2C UART CRC6 (0x300E)**

| BIT         | 7                   | 6 | 5 | 4 | 3 | 2 | 1 | 0 |
|-------------|---------------------|---|---|---|---|---|---|---|
| Field       | MSGCNR_ERR_CNT[7:0] |   |   |   |   |   |   |   |
| Reset       | 0x00                |   |   |   |   |   |   |   |
| Access Type | Read Only           |   |   |   |   |   |   |   |

| BITFIELD       | BITS | DESCRIPTION                               |
|----------------|------|---|
| MSGCNR_ERR_CNT | 7:0  | Number of Message Counter errors observed |

**I2C UART CRC7 (0x300F)**

| BIT         | 7 | 6 | 5 | 4                    | 3 | 2            | 1           | 0                 |
|-------------|---|---|---|----------------------|---|--------------|-------------|-------------------|
| Field       | – | – | – | MSGCNR_PORT_SEL[1:0] |   | CC_MSGCNR_EN | CC_CRC_EN   | CC_CRC_MSGCNR_OVR |
| Reset       | – | – | – | 0b00                 |   | 0b1          | 0b1         | 0b0               |
| Access Type | – | – | – | Write, Read          |   | Write, Read  | Write, Read | Write, Read       |

| BITFIELD        | BITS | DESCRIPTION   | DECODE  |
|-----------------|------|---|---|
| MSGCNR_PORT_SEL | 4:3  | Selects the current message/CRC counter<br><br>Selects between the ports for values read from MSGCCNTR_LSB/MSB, MSGCNR_ERR_CNT, CRC_VAL, and CRC_ERR_CNT. | 0x0: Primary I <sup>2</sup> C/UART interface<br>0x1: I <sup>2</sup> C/UART pass-through 1<br>0x2: I <sup>2</sup> C/UART pass-through 2<br>0x3: Reserved |

| BITFIELD           | BITS | DESCRIPTION   | DECODE  |
|--------------------|------|---|---|
| CC_MSGCNTR_EN      | 2    | Enable I <sup>2</sup> C/UART Message Counter override when set to 1<br>Only active when CC_CRC_MSGCNTR_OVR = 1.                       | 0b0: Reporting disabled<br>0b1: Reporting enabled |
| CC_CRC_EN          | 1    | Enable I <sup>2</sup> C/UART CRC override when set to 1<br>Only active when CC_CRC_MSGCNTR_OVR = 1.                                   | 0b0: Reporting disabled<br>0b1: Reporting enabled |
| CC_CRC_MSGCNTR_OVR | 0    | Enable I <sup>2</sup> C/UART CRC or Message Counter override when set to 1<br>When 0, eFuse controls CRC and Message Counter options. | 0b0: Reporting disabled<br>0b1: Reporting enabled |

**FS\_INTR0 (0x3010)**

| BIT         | 7                        | 6                      | 5                 | 4                 | 3 | 2 | 1                   | 0               |
|-------------|--------------------------|------------------------|-------------------|-------------------|---|---|---------------------|-----------------|
| Field       | I2C_UART_MSGCNTR_ERR_OEN | I2C_UART_CRC_ERR_R_OEN | MEM_ECC_ERR_2_OEN | MEM_ECC_ERR_1_OEN | – | – | EFUSE_CRC_ERR_R_OEN | REG_CRC_ERR_OEN |
| Reset       | 0b1                      | 0b1                    | 0b1               | 0b0               | – | – | 0b1                 | 0b0             |
| Access Type | Write, Read              | Write, Read            | Write, Read       | Write, Read       | – | – | Write, Read         | Write, Read     |

| BITFIELD                 | BITS | DESCRIPTION   | DECODE  |
|--------------------------|------|---|---|
| I2C_UART_MSGCNTR_ERR_OEN | 7    | Enable reporting of I <sup>2</sup> C/UART Message Counter errors (I2C_UART_MSGCNTR_ERR_INT) at ERRB pin | 0b0: Reporting disabled<br>0b1: Reporting enabled |
| I2C_UART_CRC_ERR_OEN     | 6    | Enable reporting of I <sup>2</sup> C/UART CRC errors (I2C_UART_CRC_ERR_INT) at ERRB pin                 | 0b0: Reporting disabled<br>0b1: Reporting enabled |
| MEM_ECC_ERR2_OEN         | 5    | Enable reporting of memory ECC 2-bit uncorrectable errors at ERRB pin                                   | 0b0: Reporting disabled<br>0b1: Reporting enabled |
| MEM_ECC_ERR1_OEN         | 4    | Enable reporting of memory ECC 1-bit correctable errors at ERRB pin                                     | 0b0: Reporting disabled<br>0b1: Reporting enabled |
| EFUSE_CRC_ERR_OEN        | 1    | Enable reporting eFuse CRC at ERRB pin  | 0b0: Reporting disabled<br>0b1: Reporting enabled |
| REG_CRC_ERR_OEN          | 0    | Enable reporting register CRC at ERRB pin   | 0b0: Reporting disabled<br>0b1: Reporting enabled |

**FS\_INTR1 (0x3011)**

| BIT | 7 | 6 | 5 | 4 | 3 | 2 | 1 | 0 |
|-----|---|---|---|---|---|---|---|---|
|-----|---|---|---|---|---|---|---|---|

|                    |                          |                      |                  |                  |   |   |                    |                  |
|--------------------|--------------------------|----------------------|------------------|------------------|---|---|--------------------|------------------|
| <b>Field</b>       | I2C_UART_MSGCNTR_ERR_INT | I2C_UART_CRC_ERR_INT | MEM_ECC_ERR2_INT | MEM_ECC_ERR1_INT | - | - | EFUSE_CRC_ERR_FLAG | REG_CRC_ERR_FLAG |
| <b>Reset</b>       | 0b0                      | 0b0                  | 0b0              | 0b0              | - | - | 0b0                | 0b0              |
| <b>Access Type</b> | Read Only                | Read Only            | Read Only        | Read Only        | - | - | Read Only          | Read Only        |

| BITFIELD                 | BITS | DESCRIPTION   | DECODE                                       |
|--------------------------|------|---|--|
| I2C_UART_MSGCNTR_ERR_INT | 7    | I <sup>2</sup> C/UART Message Counter error, asserted when MSGCNTR_ERR_CNT ≥ MSGCNTR_ERR_THR.                     | 0b0: Flag not asserted<br>0b1: Flag asserted |
| I2C_UART_CRC_ERR_INT     | 6    | I <sup>2</sup> C/UART CRC error, asserted when CRC_ERR_CNT ≥ CRC_ERR_THR  | 0b0: Flag not asserted<br>0b1: Flag asserted |
| MEM_ECC_ERR2_INT         | 5    | Decoding error flag for 2-bit uncorrectable memory ECC errors, asserted when MEM_ECC_ERR2_CNT ≥ MEM_ECC_ERR2_THR. | 0b0: Flag not asserted<br>0b1: Flag asserted |
| MEM_ECC_ERR1_INT         | 4    | Decoding error flag for 1-bit correctable memory ECC errors, asserted when MEM_ECC_ERR1_CNT ≥ MEM_ECC_ERR1_THR.   | 0b0: Flag not asserted<br>0b1: Flag asserted |
| EFUSE_CRC_ERR_FLAG       | 1    | An error occurred on the eFuse CRC calculation  | 0b0: Flag not asserted<br>0b1: Flag asserted |
| REG_CRC_ERR_FLAG         | 0    | An error occurred on the register CRC calculation   | 0b0: Flag not asserted<br>0b1: Flag asserted |

**MEM ECC0 (0x3016)**

| BIT                | 7                     | 6 | 5 | 4                     | 3 | 2 | 1                      | 0                      |
|--------------------|-----------------------|---|---|-----------------------|---|---|------------------------|------------------------|
| <b>Field</b>       | MEM_ECC_ERR2_THR[2:0] |   |   | MEM_ECC_ERR1_THR[2:0] |   |   | RESET_MEM_ECC_ERR2_CNT | RESET_MEM_ECC_ERR1_CNT |
| <b>Reset</b>       | 0b000                 |   |   | 0b000                 |   |   | 0b0                    | 0b0                    |
| <b>Access Type</b> | Write, Read           |   |   | Write, Read           |   |   | Write Clears All, Read | Write Clears All, Read |

| BITFIELD         | BITS | DESCRIPTION   | DECODE  |
|------------------|------|---|---|
| MEM_ECC_ERR2_THR | 7:5  | Decoding and error reporting threshold.<br><br>MEM_ECC_ERR2 is asserted when MEM_ECC_ERR2_CNT ≥ MEM_ECC_ERR2_THR. | 0b000: 1<br>0b001: 2<br>0b010: 4<br>0b011: 8<br>0b101: 16<br>0b101: 32<br>0b110: 64<br>0b111: 128 |

| BITFIELD               | BITS | DESCRIPTION  | DECODE  |
|------------------------|------|--|---|
| MEM_ECC_ERR1_THR       | 4:2  | Decoding and error reporting threshold<br>MEM_ECC_ERR1 is asserted when<br>MEM_ECC_ERR1_CNT ≥<br>MEM_ECC_ERR1_THR. | 0b000: 1<br>0b001: 2<br>0b010: 4<br>0b011: 8<br>0b101: 16<br>0b101: 32<br>0b110: 64<br>0b111: 128 |
| RESET_MEM_ECC_ERR2_CNT | 1    | Reset memory ECC 2-bit error count to 0  | 0b0: Reset deasserted<br>0b1: Reset asserted  |
| RESET_MEM_ECC_ERR1_CNT | 0    | Reset memory ECC 1-bit error count to 0  | 0b0: Reset deasserted<br>0b1: Reset asserted  |

**MEM ECC1 (0x3017)**

| BIT         | 7                     | 6 | 5 | 4 | 3 | 2 | 1 | 0 |
|-------------|-----------------------|---|---|---|---|---|---|---|
| Field       | MEM_ECC_ERR1_CNT[7:0] |   |   |   |   |   |   |   |
| Reset       | 0x00                  |   |   |   |   |   |   |   |
| Access Type | Read Only             |   |   |   |   |   |   |   |

| BITFIELD         | BITS | DESCRIPTION  |
|------------------|------|--|
| MEM_ECC_ERR1_CNT | 7:0  | Number of 1-bit correctable memory ECC errors observed |

**MEM ECC2 (0x3018)**

| BIT         | 7                     | 6 | 5 | 4 | 3 | 2 | 1 | 0 |
|-------------|-----------------------|---|---|---|---|---|---|---|
| Field       | MEM_ECC_ERR2_CNT[7:0] |   |   |   |   |   |   |   |
| Reset       | 0x00                  |   |   |   |   |   |   |   |
| Access Type | Read Only             |   |   |   |   |   |   |   |

| BITFIELD         | BITS | DESCRIPTION  |
|------------------|------|--|
| MEM_ECC_ERR2_CNT | 7:0  | Number of 2-bit uncorrectable memory ECC errors observed |

**REG POST0 (0x3020)**

| BIT   | 7         | 6                 | 5                 | 4 | 3 | 2 | 1              | 0              |
|-------|-----------|-------------------|-------------------|---|---|---|----------------|----------------|
| Field | POST_DONE | POST_MBIST_PASSED | POST_LBIST_PASSED | – | – | – | POST_RUN_MBIST | POST_RUN_LBIST |
| Reset | 0b0       | 0b0               | 0b0               | – | – | – | 0b0            | 0b0            |

|                    |           |           |           |   |   |   |           |           |
|--------------------|-----------|-----------|-----------|---|---|---|-----------|-----------|
| <b>Access Type</b> | Read Only | Read Only | Read Only | - | - | - | Read Only | Read Only |
|--------------------|-----------|-----------|-----------|---|---|---|-----------|-----------|

| BITFIELD          | BITS | DESCRIPTION  | DECODE   |
|-------------------|------|--|--|
| POST_DONE         | 7    | Power-on-self-test (POST) (LBIST and/or MBIST) is run                    | 0b0: POST is not run<br>0b1: POST is run   |
| POST_MBIST_PASSED | 6    | MBIST passed during POST. Valid when POST_DONE is asserted.              | 0b0: MBIST failed during POST run (or is not enabled)<br>0b1: MBIST passed during POST run |
| POST_LBIST_PASSED | 5    | LBIST passed during POST. Valid when POST_DONE is asserted.              | 0b0: LBIST failed during POST run (or is not enabled)<br>0b1: LBIST passed during POST run |
| POST_RUN_MBIST    | 1    | Indicates if this device is enabled to run MBIST during POST. Read-only. | 0b0: MBIST disabled<br>0b1: MBIST enabled  |
| POST_RUN_LBIST    | 0    | Indicates if this device is enabled to run LBIST during POST. Read-only. | 0b0: LBIST disabled<br>0b1: LBIST enabled  |

**REGCRC8 (0x3030)**

|                    |                |          |          |          |          |          |          |          |
|--------------------|----------------|----------|----------|----------|----------|----------|----------|----------|
| <b>BIT</b>         | <b>7</b>       | <b>6</b> | <b>5</b> | <b>4</b> | <b>3</b> | <b>2</b> | <b>1</b> | <b>0</b> |
| <b>Field</b>       | SKIP0_LSB[7:0] |          |          |          |          |          |          |          |
| <b>Reset</b>       | 0xFF           |          |          |          |          |          |          |          |
| <b>Access Type</b> | Write, Read    |          |          |          |          |          |          |          |

| BITFIELD  | BITS | DESCRIPTION  | DECODE               |
|-----------|------|--|----------------------|
| SKIP0_LSB | 7:0  | Address 0 to skip (LSB). This can be used to exclude whole registers from the CRC calculation. | 0xXX: LSB of address |

**REGCRC9 (0x3031)**

|                    |                |          |          |          |          |          |          |          |
|--------------------|----------------|----------|----------|----------|----------|----------|----------|----------|
| <b>BIT</b>         | <b>7</b>       | <b>6</b> | <b>5</b> | <b>4</b> | <b>3</b> | <b>2</b> | <b>1</b> | <b>0</b> |
| <b>Field</b>       | SKIP0_MSB[7:0] |          |          |          |          |          |          |          |
| <b>Reset</b>       | 0xFF           |          |          |          |          |          |          |          |
| <b>Access Type</b> | Write, Read    |          |          |          |          |          |          |          |

| BITFIELD  | BITS | DESCRIPTION   | DECODE               |
|-----------|------|---|----------------------|
| SKIPO_MSB | 7:0  | Address 0 to skip (MSB).<br>This can be used to exclude whole registers from the CRC calculation. | 0xXX: MSB of address |

**REGCRC10 (0x3032)**

| BIT         | 7              | 6 | 5 | 4 | 3 | 2 | 1 | 0 |
|-------------|----------------|---|---|---|---|---|---|---|
| Field       | SKIP1_LSB[7:0] |   |   |   |   |   |   |   |
| Reset       | 0xFF           |   |   |   |   |   |   |   |
| Access Type | Write, Read    |   |   |   |   |   |   |   |

| BITFIELD  | BITS | DESCRIPTION   | DECODE               |
|-----------|------|---|----------------------|
| SKIP1_LSB | 7:0  | Address 1 to skip (LSB).<br>This can be used to exclude whole registers from the CRC calculation. | 0xXX: LSB of address |

**REGCRC11 (0x3033)**

| BIT         | 7              | 6 | 5 | 4 | 3 | 2 | 1 | 0 |
|-------------|----------------|---|---|---|---|---|---|---|
| Field       | SKIP1_MSB[7:0] |   |   |   |   |   |   |   |
| Reset       | 0xFF           |   |   |   |   |   |   |   |
| Access Type | Write, Read    |   |   |   |   |   |   |   |

| BITFIELD  | BITS | DESCRIPTION   | DECODE               |
|-----------|------|---|----------------------|
| SKIP1_MSB | 7:0  | Address 1 to skip (MSB).<br>This can be used to exclude whole registers from the CRC calculation. | 0xXX: MSB of address |

**REGCRC12 (0x3034)**

| BIT         | 7              | 6 | 5 | 4 | 3 | 2 | 1 | 0 |
|-------------|----------------|---|---|---|---|---|---|---|
| Field       | SKIP2_LSB[7:0] |   |   |   |   |   |   |   |
| Reset       | 0xFF           |   |   |   |   |   |   |   |
| Access Type | Write, Read    |   |   |   |   |   |   |   |

| BITFIELD  | BITS | DESCRIPTION   | DECODE               |
|-----------|------|---|----------------------|
| SKIP2_LSB | 7:0  | Address 2 to skip (LSB).<br>This can be used to exclude whole registers from the CRC calculation. | 0xXX: LSB of address |

**REGCRC13 (0x3035)**

| BIT         | 7              | 6 | 5 | 4 | 3 | 2 | 1 | 0 |
|-------------|----------------|---|---|---|---|---|---|---|
| Field       | SKIP2_MSB[7:0] |   |   |   |   |   |   |   |
| Reset       | 0xFF           |   |   |   |   |   |   |   |
| Access Type | Write, Read    |   |   |   |   |   |   |   |

| BITFIELD  | BITS | DESCRIPTION   | DECODE               |
|-----------|------|---|----------------------|
| SKIP2_MSB | 7:0  | Address 2 to skip (MSB).<br>This can be used to exclude whole registers from the CRC calculation. | 0xXX: MSB of address |

**REGCRC14 (0x3036)**

| BIT         | 7              | 6 | 5 | 4 | 3 | 2 | 1 | 0 |
|-------------|----------------|---|---|---|---|---|---|---|
| Field       | SKIP3_LSB[7:0] |   |   |   |   |   |   |   |
| Reset       | 0xFF           |   |   |   |   |   |   |   |
| Access Type | Write, Read    |   |   |   |   |   |   |   |

| BITFIELD  | BITS | DESCRIPTION   | DECODE               |
|-----------|------|---|----------------------|
| SKIP3_LSB | 7:0  | Address 3 to skip (LSB).<br>This can be used to exclude whole registers from the CRC calculation. | 0xXX: LSB of address |

**REGCRC15 (0x3037)**

| BIT   | 7              | 6 | 5 | 4 | 3 | 2 | 1 | 0 |
|-------|----------------|---|---|---|---|---|---|---|
| Field | SKIP3_MSB[7:0] |   |   |   |   |   |   |   |
| Reset | 0xFF           |   |   |   |   |   |   |   |

|                    |             |
|--------------------|-------------|
| <b>Access Type</b> | Write, Read |
|--------------------|-------------|

| <b>BITFIELD</b> | <b>BITS</b> | <b>DESCRIPTION</b>  | <b>DECODE</b>        |
|-----------------|-------------|---|----------------------|
| SKIP3_MSB       | 7:0         | Address 3 to skip (MSB).<br>This can be used to exclude whole registers from the CRC calculation. | 0xXX: MSB of address |

**REGCRC16 (0x3038)**

| <b>BIT</b>         | <b>7</b>       | <b>6</b> | <b>5</b> | <b>4</b> | <b>3</b> | <b>2</b> | <b>1</b> | <b>0</b> |
|--------------------|----------------|----------|----------|----------|----------|----------|----------|----------|
| <b>Field</b>       | SKIP4_LSB[7:0] |          |          |          |          |          |          |          |
| <b>Reset</b>       | 0xFF           |          |          |          |          |          |          |          |
| <b>Access Type</b> | Write, Read    |          |          |          |          |          |          |          |

| <b>BITFIELD</b> | <b>BITS</b> | <b>DESCRIPTION</b>  | <b>DECODE</b>        |
|-----------------|-------------|---|----------------------|
| SKIP4_LSB       | 7:0         | Address 4 to skip (LSB).<br>This can be used to exclude whole registers from the CRC calculation. | 0xXX: LSB of address |

**REGCRC17 (0x3039)**

| <b>BIT</b>         | <b>7</b>       | <b>6</b> | <b>5</b> | <b>4</b> | <b>3</b> | <b>2</b> | <b>1</b> | <b>0</b> |
|--------------------|----------------|----------|----------|----------|----------|----------|----------|----------|
| <b>Field</b>       | SKIP4_MSB[7:0] |          |          |          |          |          |          |          |
| <b>Reset</b>       | 0xFF           |          |          |          |          |          |          |          |
| <b>Access Type</b> | Write, Read    |          |          |          |          |          |          |          |

| <b>BITFIELD</b> | <b>BITS</b> | <b>DESCRIPTION</b>  | <b>DECODE</b>        |
|-----------------|-------------|---|----------------------|
| SKIP4_MSB       | 7:0         | Address 4 to skip (MSB).<br>This can be used to exclude whole registers from the CRC calculation. | 0xXX: MSB of address |

**REGCRC18 (0x303A)**

| <b>BIT</b>   | <b>7</b>       | <b>6</b> | <b>5</b> | <b>4</b> | <b>3</b> | <b>2</b> | <b>1</b> | <b>0</b> |
|--------------|----------------|----------|----------|----------|----------|----------|----------|----------|
| <b>Field</b> | SKIP5_LSB[7:0] |          |          |          |          |          |          |          |

|                    |             |
|--------------------|-------------|
| <b>Reset</b>       | 0xFF        |
| <b>Access Type</b> | Write, Read |

| <b>BITFIELD</b> | <b>BITS</b> | <b>DESCRIPTION</b>  | <b>DECODE</b>        |
|-----------------|-------------|---|----------------------|
| SKIP5_LSB       | 7:0         | Address 5 to skip (LSB).<br>This can be used to exclude whole registers from the CRC calculation. | 0xXX: LSB of address |

**REGCRC19 (0x303B)**

| <b>BIT</b>         | <b>7</b>       | <b>6</b> | <b>5</b> | <b>4</b> | <b>3</b> | <b>2</b> | <b>1</b> | <b>0</b> |
|--------------------|----------------|----------|----------|----------|----------|----------|----------|----------|
| <b>Field</b>       | SKIP5_MSB[7:0] |          |          |          |          |          |          |          |
| <b>Reset</b>       | 0xFF           |          |          |          |          |          |          |          |
| <b>Access Type</b> | Write, Read    |          |          |          |          |          |          |          |

| <b>BITFIELD</b> | <b>BITS</b> | <b>DESCRIPTION</b>  | <b>DECODE</b>        |
|-----------------|-------------|---|----------------------|
| SKIP5_MSB       | 7:0         | Address 5 to skip (MSB).<br>This can be used to exclude whole registers from the CRC calculation. | 0xXX: MSB of address |

**REGCRC20 (0x303C)**

| <b>BIT</b>         | <b>7</b>       | <b>6</b> | <b>5</b> | <b>4</b> | <b>3</b> | <b>2</b> | <b>1</b> | <b>0</b> |
|--------------------|----------------|----------|----------|----------|----------|----------|----------|----------|
| <b>Field</b>       | SKIP6_LSB[7:0] |          |          |          |          |          |          |          |
| <b>Reset</b>       | 0xFF           |          |          |          |          |          |          |          |
| <b>Access Type</b> | Write, Read    |          |          |          |          |          |          |          |

| <b>BITFIELD</b> | <b>BITS</b> | <b>DESCRIPTION</b>  | <b>DECODE</b>        |
|-----------------|-------------|---|----------------------|
| SKIP6_LSB       | 7:0         | Address 6 to skip (LSB).<br>This can be used to exclude whole registers from the CRC calculation. | 0xXX: LSB of address |

**REGCRC21 (0x303D)**

| <b>BIT</b> | <b>7</b> | <b>6</b> | <b>5</b> | <b>4</b> | <b>3</b> | <b>2</b> | <b>1</b> | <b>0</b> |
|------------|----------|----------|----------|----------|----------|----------|----------|----------|
|------------|----------|----------|----------|----------|----------|----------|----------|----------|

|                    |                |
|--------------------|----------------|
| <b>Field</b>       | SKIP6_MSB[7:0] |
| <b>Reset</b>       | 0xFF           |
| <b>Access Type</b> | Write, Read    |

| <b>BITFIELD</b> | <b>BITS</b> | <b>DESCRIPTION</b>  | <b>DECODE</b>        |
|-----------------|-------------|---|----------------------|
| SKIP6_MSB       | 7:0         | Address 6 to skip (MSB).<br>This can be used to exclude whole registers from the CRC calculation. | 0xXX: MSB of address |

**REGCRC22 (0x303E)**

| <b>BIT</b>         | <b>7</b>       | <b>6</b> | <b>5</b> | <b>4</b> | <b>3</b> | <b>2</b> | <b>1</b> | <b>0</b> |
|--------------------|----------------|----------|----------|----------|----------|----------|----------|----------|
| <b>Field</b>       | SKIP7_LSB[7:0] |          |          |          |          |          |          |          |
| <b>Reset</b>       | 0xFF           |          |          |          |          |          |          |          |
| <b>Access Type</b> | Write, Read    |          |          |          |          |          |          |          |

| <b>BITFIELD</b> | <b>BITS</b> | <b>DESCRIPTION</b>  | <b>DECODE</b>        |
|-----------------|-------------|---|----------------------|
| SKIP7_LSB       | 7:0         | Address 7 to skip (LSB).<br>This can be used to exclude whole registers from the CRC calculation. | 0xXX: LSB of address |

**REGCRC23 (0x303F)**

| <b>BIT</b>         | <b>7</b>       | <b>6</b> | <b>5</b> | <b>4</b> | <b>3</b> | <b>2</b> | <b>1</b> | <b>0</b> |
|--------------------|----------------|----------|----------|----------|----------|----------|----------|----------|
| <b>Field</b>       | SKIP7_MSB[7:0] |          |          |          |          |          |          |          |
| <b>Reset</b>       | 0xFF           |          |          |          |          |          |          |          |
| <b>Access Type</b> | Write, Read    |          |          |          |          |          |          |          |

| <b>BITFIELD</b> | <b>BITS</b> | <b>DESCRIPTION</b>  | <b>DECODE</b>        |
|-----------------|-------------|---|----------------------|
| SKIP7_MSB       | 7:0         | Address 7 to skip (MSB).<br>This can be used to exclude whole registers from the CRC calculation. | 0xXX: MSB of address |

**CC RTTN\_ERR (0x304F)**

| BIT         | 7 | 6 | 5 | 4 | 3 | 2                      | 1                    | 0                   |
|-------------|---|---|---|---|---|------------------------|----------------------|---------------------|
| Field       | – | – | – | – | – | RESET_EFUSE_CRC_ERR    | INJECT_EFUSE_CRC_ERR | INJECT_RTTN_CRC_ERR |
| Reset       | – | – | – | – | – | 0b0                    | 0b0                  | 0b0                 |
| Access Type | – | – | – | – | – | Write Clears All, Read | Write, Read          | Write, Read         |

| BITFIELD             | BITS | DESCRIPTION  | DECODE  |
|----------------------|------|--|---|
| RESET_EFUSE_CRC_ERR  | 2    | Reset eFuse CRC error status to 0  |   |
| INJECT_EFUSE_CRC_ERR | 1    | Set this bit before reading eFuse values to inject error to eFuse CRC value. Use for ASIL evaluation purposes. | 0b0: Do not inject eFuse CRC errors<br>0b1: Inject eFuse CRC errors                       |
| INJECT_RTTN_CRC_ERR  | 0    | Set this bit before going into sleep mode to inject error to RTTN CRC value. Use for ASIL evaluation purposes. | 0b0: Do not inject retention memory CRC errors<br>0b1: Inject retention memory CRC errors |

**CTRL9 (0x5009)**

| BIT         | 7 | 6 | 5 | 4 | 3         | 2 | 1 | 0 |
|-------------|---|---|---|---|-----------|---|---|---|
| Field       | – | – | – | – | LOCKED_B  | – | – | – |
| Reset       | – | – | – | – | 0b0       | – | – | – |
| Access Type | – | – | – | – | Read Only | – | – | – |

| BITFIELD | BITS | DESCRIPTION  | DECODE   |
|----------|------|--|--|
| LOCKED_B | 3    | GMSL link locked (bidirectional). For Link B only. | 0b0: GMSL link B not locked<br>0b1: GMSL link B locked |

**INTR10 (0x5010)**

| BIT         | 7                | 6              | 5                | 4            | 3            | 2            | 1             | 0           |
|-------------|------------------|----------------|------------------|--------------|--------------|--------------|---------------|-------------|
| Field       | RTTN_CRC_ERR_OEN | IDLE_ERR_OEN_B | FEC_RX_ERR_OEN_B | VDD18_OV_OEN | MAX_RT_OEN_B | RT_CNT_OEN_B | PKT_CNT_OEN_B | VDD_OV_OEN  |
| Reset       | 0b1              | 0b0            | 0b0              | 0b0          | 0b1          | 0b0          | 0b0           | 0b0         |
| Access Type | Write, Read      | Write, Read    | Write, Read      | Write, Read  | Write, Read  | Write, Read  | Write, Read   | Write, Read |

| BITFIELD         | BITS | DESCRIPTION  | DECODE  |
|------------------|------|--|---|
| RTTN_CRC_ERR_OEN | 7    | Retention Memory Restore CRC Error Output Enable<br><br>If this bit is set, RTTN_CRC_ERR is passed on to the ERRB logic and affects the ERRB output. | 0b0: Disabled<br>0b1: Enabled                     |
| IDLE_ERR_OEN_B   | 6    | Enable reporting of Link B idle-word errors (IDLE_ERR_FLAG_B) at ERRB pin.   | 0b0: Reporting disabled<br>0b1: Reporting enabled |
| FEC_RX_ERR_OEN_B | 5    | Enable reporting of Link B FEC receive errors exceeding thresholds (FEC_ERR_FLAG) at ERRB pin.   | 0b0: Reporting disabled<br>0b1: Reporting enabled |
| VDD18_OV_OEN     | 4    | Enable V <sub>DD18</sub> overvoltage status on ERRB  | 0b0: Reporting disabled<br>0b1: Reporting enabled |
| MAX_RT_OEN_B     | 3    | Enable reporting of Link B combined ARQ maximum retransmission limit error flag (MAX_RT_FLAG) at ERRB pin.   | 0b0: Reporting disabled<br>0b1: Reporting enabled |
| RT_CNT_OEN_B     | 2    | Enable reporting of Link B combined ARQ retransmission event flag (RT_CNT_FLAG) at ERRB pin.   | 0b0: Reporting disabled<br>0b1: Reporting enabled |
| PKT_CNT_OEN_B    | 1    | Enable reporting of Link B packet count flag (PKT_CNT_FLAG_B) at ERRB pin.   | 0b0: Reporting disabled<br>0b1: Reporting enabled |
| VDD_OV_OEN       | 0    | Enable V <sub>DD</sub> overvoltage status on ERRB  | 0b0: Reporting disabled<br>0b1: Reporting enabled |

**INTR11 (0x5011)**

| BIT         | 7            | 6               | 5                 | 4               | 3             | 2             | 1              | 0               |
|-------------|--------------|-----------------|-------------------|-----------------|---------------|---------------|----------------|-----------------|
| Field       | RTTN_CRC_INT | IDLE_ERR_FLAG_B | FEC_RX_ERR_FLAG_B | VDD18_OV_FLAG   | MAX_RT_FLAG_B | RT_CNT_FLAG_B | PKT_CNT_FLAG_B | VDD_OV_FLAG     |
| Reset       | 0b0          | 0b0             | 0b0               | 0b0             | 0b0           | 0b0           | 0b0            | 0b0             |
| Access Type | Read Only    | Read Only       | Read Only         | Read Clears All | Read Only     | Read Only     | Read Only      | Read Clears All |

| BITFIELD          | BITS | DESCRIPTION   | DECODE                                       |
|-------------------|------|---|--|
| RTTN_CRC_INT      | 7    | Retention Memory Restore CRC Error Interrupt.<br><br>When the device wakes up, contents of retention memory is loaded back to main registers. The restored data is covered by CRC. If CRC fails, this bit is set. | 0b0: Flag not asserted<br>0b1: Flag asserted |
| IDLE_ERR_FLAG_B   | 6    | Idle-Word Error Flag for Link B<br><br>Asserted when IDLE_ERR_B ≥ DEC_ERR_THR.  | 0b0: Flag not asserted<br>0b1: Flag asserted |
| FEC_RX_ERR_FLAG_B | 5    | FEC Receive Errors Flag for Link B<br><br>Asserted when the FEC receiver correctable OR uncorrectable error counters exceeded their   | 0b0: Flag not asserted<br>0b1: Flag asserted |

| BITFIELD       | BITS | DESCRIPTION   | DECODE   |
|----------------|------|---|--|
|                |      | thresholds for the first time. When reading this flag, the status gets cleared. Reset the FEC statistics counters for this flag to be asserted again. See the CLEAR_STATS register to reset the counters.                 |  |
| VDD18_OV_FLAG  | 4    | Sticky status value for V <sub>DD</sub> overvoltage   | 0b0: Overvoltage condition not detected<br>0b1: Overvoltage condition detected |
| MAX_RT_FLAG_B  | 3    | Combined ARQ maximum retransmission limit error flag for Link B.<br><br>Asserted when any of the selected channel's ARQ retransmission limit is reached. Selection is done by each channel's MAX_RT_ERR_OEN register bit. | 0b0: Flag not asserted<br>0b1: Flag asserted                                   |
| RT_CNT_FLAG_B  | 2    | Combined ARQ retransmission event flag for Link B<br><br>Asserted when any of the selected channels have done at least one ARQ retransmission. Selection is done by each channel's RT_CNT_OEN register bit.               | 0b0: Flag not asserted<br>0b1: Flag asserted                                   |
| PKT_CNT_FLAG_B | 1    | Packet Count Flag for Link B<br><br>Asserted when PKT_CNT_B ≥ PKT_CNT_THR.  | 0b0: Flag not asserted<br>0b1: Flag asserted                                   |
| VDD_OV_FLAG    | 0    | Sticky status value for V <sub>DD</sub> overvoltage flag  | 0b0: Overvoltage condition not detected<br>0b1: Overvoltage condition detected |

**INTR13 (0x5012)**

| BIT         | 7                  | 6                  | 5 | 4 | 3 | 2 | 1                      | 0                |
|-------------|--------------------|--------------------|---|---|---|---|------------------------|------------------|
| Field       | FEC_B_INACTIVE_OEN | FEC_A_INACTIVE_OEN | – | – | – | – | video_mem_overflow_oen | LOSS_OF_LOCK_OEN |
| Reset       | 0b0                | 0b0                | – | – | – | – | 0b0                    | 0b0              |
| Access Type | Write, Read        | Write, Read        | – | – | – | – | Write, Read            | Write, Read      |

| BITFIELD               | BITS | DESCRIPTION   | DECODE  |
|------------------------|------|---|---|
| FEC_B_INACTIVE_OEN     | 7    | Enable reporting of link B FEC handshake error (FEC_B_INACTIVE) at the ERRB pin.              | 0x0: Reporting is disabled<br>0x1: Reporting is enabled |
| FEC_A_INACTIVE_OEN     | 6    | Enable reporting of link A FEC handshake error (FEC_A_INACTIVE) at the ERRB pin.              | 0x0: Reporting is disabled<br>0x1: Reporting is enabled |
| video_mem_overflow_oen | 1    | Enable reporting of BACKTOP video memory overflow error (video_mem_overflow) at the ERRB pin. | 0x0: Reporting is disabled<br>0x1: Reporting is enabled |
| LOSS_OF_LOCK_OEN       | 0    | Enable reporting loss-of-lock detection (LOSS_OF_LOCK_FLAG) at the ERRB pin.                  | 0x0: Reporting is disabled<br>0x1: Reporting is enabled |

**INTR14 (0x5013)**

| BIT         | 7               | 6               | 5 | 4 | 3 | 2 | 1                  | 0                 |
|-------------|-----------------|-----------------|---|---|---|---|--------------------|-------------------|
| Field       | FEC_B_INACTIVE  | FEC_A_INACTIVE  | – | – | – | – | video_mem_overflow | LOSS_OF_LOCK_FLAG |
| Reset       | 0b0             | 0b0             | – | – | – | – | 0b0                | 0b0               |
| Access Type | Read Clears All | Read Clears All | – | – | – | – | Read Only          | Read Clears All   |

| BITFIELD           | BITS | DESCRIPTION  | DECODE   |
|--------------------|------|--|--|
| FEC_B_INACTIVE     | 7    | Error flag indicating that when the FEC decoder on Link B is enabled through the config pin, the expected FEC encoder handshake InfoFrame from the serializer is not received 1ms past Link B lock. The handshake is required before the FEC decoder is officially turned ON. This is a clear-on-read sticky error flag.   | 0x0: No error is detected<br>0x1: Error is detected  |
| FEC_A_INACTIVE     | 6    | Error flag indicating that when the FEC decoder on Link A is enabled through the config pin, the expected FEC encoder handshake InfoFrame from the serializer is not received 1ms past Link A lock. The handshake is required before the FEC decoder is officially turned ON. This is a clear-on-read sticky error flag.   | 0x0: No error is detected<br>0x1: Error is detected  |
| video_mem_overflow | 1    | Flag indicating that one or more of the following BACKTOP memory overflow errors are detected:<br>1) Video pipe Y Line Memory Overflow (LMO_Y)<br>2) Video pipe Z Line Memory Overflow (LMO_Z)<br>3) Video pipe Y Command FIFO overflow (cmd_overflow2)<br>4) Video pipe Z Command FIFO overflow (cmd_overflow3)<br><br>Poll the individual error flags, LMO_Y, LMO_Z, cmd_overflow2, and cmd_overflow3 in the BACKTOP11 register to determine which specific error(s) are detected. | 0x0: No BACKTOP memory overflow errors are detected<br>0x1: One of more BACKTOP memory overflow errors are detected  |
| LOSS_OF_LOCK_FLAG  | 0    | Loss of lock detection flag (sticky)   | 0x0: No loss of GMSL lock or MIPI video output is detected<br>0x1: Loss of GMSL lock (lock_cfg=0) or loss of MIPI video output (lock_cfg=1) detection flag |

**INTR12 (0x5018)**

| BIT         | 7 | 6 | 5 | 4                | 3 | 2 | 1 | 0 |
|-------------|---|---|---|------------------|---|---|---|---|
| Field       | – | – | – | ERR_RX_ID_B[4:0] |   |   |   |   |
| Reset       | – | – | – | 0b11111          |   |   |   |   |
| Access Type | – | – | – | Write, Read      |   |   |   |   |

| BITFIELD    | BITS | DESCRIPTION                                  | DECODE   |
|-------------|------|--|--|
| ERR_RX_ID_B | 4:0  | GPIO ID used for receiving ERR_RX for Link B | 0bXXXXX: Value of GPIO ID for receiving ERR_RX |

**CNT2 (0x5024)**

| BIT         | 7               | 6 | 5 | 4 | 3 | 2 | 1 | 0 |
|-------------|-----------------|---|---|---|---|---|---|---|
| Field       | IDLE_ERR_B[7:0] |   |   |   |   |   |   |   |
| Reset       | 0x00            |   |   |   |   |   |   |   |
| Access Type | Read Clears All |   |   |   |   |   |   |   |

| BITFIELD   | BITS | DESCRIPTION  | DECODE                                    |
|------------|------|--|---|
| IDLE_ERR_B | 7:0  | Number of idle-word errors detected for Link B<br>Reset after reading or with the rising edge of LOCK. | 0xXX: Number of idle-word errors detected |

**CNT3 (0x5025)**

| BIT         | 7               | 6 | 5 | 4 | 3 | 2 | 1 | 0 |
|-------------|-----------------|---|---|---|---|---|---|---|
| Field       | PKT_CNT_B[7:0]  |   |   |   |   |   |   |   |
| Reset       | 0x00            |   |   |   |   |   |   |   |
| Access Type | Read Clears All |   |   |   |   |   |   |   |

| BITFIELD  | BITS | DESCRIPTION   | DECODE                                  |
|-----------|------|---|---|
| PKT_CNT_B | 7:0  | <p>Number of received packets of a selected type for Link B.</p> <p>Packet type is selected with PKT_CNT_SEL register.</p> <p>Reported packet count is a scaled value, such that actual packet count is <math>\geq \text{PKT\_CNT} \times (2^{\text{PKT\_CNT\_EXP}})</math> and <math>&lt; (\text{PKT\_CNT} + 1) \times (2^{\text{PKT\_CNT\_EXP}})</math>.</p> <p>When maximum value is reported, packet count is greater or equal to the reported value.</p> | 0xXX: Scaled number of received packets |

**VIDEO\_RX13 (0x501A)**

| BIT         | 7 | 6 | 5 | 4 | 3 | 2 | 1 | 0                      |
|-------------|---|---|---|---|---|---|---|------------------------|
| Field       | – | – | – | – | – | – | – | LOSS_OF_VIDEO_LOCK_OEN |
| Reset       | – | – | – | – | – | – | – | 0b0                    |
| Access Type | – | – | – | – | – | – | – | Write, Read            |

| BITFIELD               | BITS | DESCRIPTION   | DECODE  |
|------------------------|------|---|---|
| LOSS_OF_VIDEO_LOCK_OEN | 0    | Enable reporting loss of pipe Y video lock (VIDEO_RX13::LOSS_OF_VIDEO_LOCK) at the ERRB pin | 0x0: Reporting is disabled<br>0x1: Reporting is enabled |

**VIDEO\_RX14 (0x501B)**

| BIT         | 7 | 6 | 5 | 4 | 3 | 2 | 1 | 0                  |
|-------------|---|---|---|---|---|---|---|--------------------|
| Field       | – | – | – | – | – | – | – | LOSS_OF_VIDEO_LOCK |
| Reset       | – | – | – | – | – | – | – | 0b0                |
| Access Type | – | – | – | – | – | – | – | Read Clears All    |

| BITFIELD           | BITS | DESCRIPTION                                       | DECODE   |
|--------------------|------|---|--|
| LOSS_OF_VIDEO_LOCK | 0    | Loss of pipe Y video lock detection flag (sticky) | 0x0: Loss of pipe Y video lock is NOT detected<br>0x1: Loss of pipe Y video lock is detected |

**VIDEO\_RX13 (0x5020)**

| BIT         | 7 | 6 | 5 | 4 | 3 | 2 | 1 | 0                      |
|-------------|---|---|---|---|---|---|---|------------------------|
| Field       | – | – | – | – | – | – | – | LOSS_OF_VIDEO_LOCK_OEN |
| Reset       | – | – | – | – | – | – | – | 0b0                    |
| Access Type | – | – | – | – | – | – | – | Write, Read            |

| BITFIELD               | BITS | DESCRIPTION   | DECODE  |
|------------------------|------|---|---|
| LOSS_OF_VIDEO_LOCK_OEN | 0    | Enable reporting loss of pipe Z video lock (VIDEO_RX14::LOSS_OF_VIDEO_LOCK) at the ERRB pin | 0x0: Reporting is disabled<br>0x1: Reporting is enabled |

**VIDEO\_RX14 (0x5021)**

| BIT         | 7 | 6 | 5 | 4 | 3 | 2 | 1 | 0                  |
|-------------|---|---|---|---|---|---|---|--------------------|
| Field       | – | – | – | – | – | – | – | LOSS_OF_VIDEO_LOCK |
| Reset       | – | – | – | – | – | – | – | 0b0                |
| Access Type | – | – | – | – | – | – | – | Read Clears All    |

| BITFIELD           | BITS | DESCRIPTION                                       | DECODE   |
|--------------------|------|---|--|
| LOSS_OF_VIDEO_LOCK | 0    | Loss of pipe Z video lock detection flag (sticky) | 0x0: Loss of pipe Z video lock is NOT detected<br>0x1: Loss of pipe Z video lock is detected |

**TX0 (0x5028)**

For GMSL Link B

| BIT         | 7 | 6 | 5 | 4 | 3 | 2 | 1           | 0 |
|-------------|---|---|---|---|---|---|-------------|---|
| Field       | – | – | – | – | – | – | RX_FEC_EN   | – |
| Reset       | – | – | – | – | – | – | 0b0         | – |
| Access Type | – | – | – | – | – | – | Write, Read | – |

| BITFIELD  | BITS | DESCRIPTION   | DECODE                      |
|-----------|------|---|-----------------------------|
| RX_FEC_EN | 1    | Enable forward error correction (FEC) on Link B in forward direction.<br>For GMSL3 parts, bit is set according to the latched CFG1 pin value at power-up. | 0b0: Disable<br>0b1: Enable |

**TX1 (0x5029)**

For GMSL Link B

| BIT         | 7             | 6 | 5 | 4           | 3 | 2 | 1 | 0 |
|-------------|---------------|---|---|-------------|---|---|---|---|
| Field       | LINK_PRBS_GEN | – | – | ERRG_EN_B   | – | – | – | – |
| Reset       | 0b0           | – | – | 0b0         | – | – | – | – |
| Access Type | Write, Read   | – | – | Write, Read | – | – | – | – |

| BITFIELD      | BITS | DESCRIPTION                  | DECODE                        |
|---------------|------|------------------------------|-------------------------------|
| LINK_PRBS_GEN | 7    | Enable link PRBS-7 generator | 0x0: Disabled<br>0x1: Enabled |

| BITFIELD  | BITS | DESCRIPTION   | DECODE  |
|-----------|------|---|---|
| ERRG_EN_B | 4    | Error generator enable for Link B (reverse channel). Error injection applies to all data going across the link. | 0b0: Link B error generator disabled<br>0b1: Link B error generator enabled |

**TX2 (0x502A)**

For GMSL Link B

| BIT         | 7             | 6 | 5              | 4 | 3               | 2 | 1 | 0           |
|-------------|---------------|---|----------------|---|-----------------|---|---|-------------|
| Field       | ERRG_CNT[1:0] |   | ERRG_RATE[1:0] |   | ERRG_BURST[2:0] |   |   | ERRG_PER    |
| Reset       | 0b00          |   | 0b10           |   | 0b000           |   |   | 0b0         |
| Access Type | Write, Read   |   | Write, Read    |   | Write, Read     |   |   | Write, Read |

| BITFIELD   | BITS | DESCRIPTION                                  | DECODE   |
|------------|------|--|--|
| ERRG_CNT   | 7:6  | Number of errors to be generated             | 0b00: Continuous<br>0b01: 16 errors<br>0b10: 128 errors<br>0b11: 1024 errors                         |
| ERRG_RATE  | 5:4  | Error-generator average-bit error rate       | 0b00: 1 in 5120 bits<br>0b01: 1 in 81920 bits<br>0b10: 1 in 1310720 bits<br>0b11: 1 in 20971520 bits |
| ERRG_BURST | 3:1  | Error-generator burst-error length           | 0b000: 1<br>0b001: 2<br>0b010: 3<br>0b011: 4<br>0b100: 8<br>0b101: 12<br>0b110: 16<br>0b111: 20      |
| ERRG_PER   | 0    | Error-generator error-distribution selection | 0b0: Pseudorandom<br>0b1: Periodic   |

**TX3 (0x502B)**

For GMSL Link B

| BIT         | 7 | 6 | 5             | 4 | 3 | 2 | 1 | 0 |
|-------------|---|---|---------------|---|---|---|---|---|
| Field       | - | - | RX_FEC_ACTIVE | - | - | - | - | - |
| Reset       | - | - | 0b0           | - | - | - | - | - |
| Access Type | - | - | Read Only     | - | - | - | - | - |

| BITFIELD      | BITS | DESCRIPTION   | DECODE                                |
|---------------|------|---------------|---------------------------------------|
| RX_FEC_ACTIVE | 5    | FEC is active | 0b0: FEC disabled<br>0b1: FEC enabled |

**RX0 (0x502C)**

For GMSL Link B

| BIT         | 7                | 6 | 5 | 4 | 3                | 2 | 1 | 0 |
|-------------|------------------|---|---|---|------------------|---|---|---|
| Field       | PKT_CNT_LBW[1:0] |   | – | – | PKT_CNT_SEL[3:0] |   |   |   |
| Reset       | 0b00             |   | – | – | 0x0              |   |   |   |
| Access Type | Write, Read      |   | – | – | Write, Read      |   |   |   |

| BITFIELD    | BITS | DESCRIPTION  | DECODE  |
|-------------|------|--|---|
| PKT_CNT_LBW | 7:6  | Select the subtype of low-bandwidth (LBW) packets to count at PKT_CNT register | 0b00: Count LBW data packets only<br>0b01: Count LBW acknowledge packets only<br>0b10: Count LBW data and acknowledge packets<br>0b11: Reserved   |
| PKT_CNT_SEL | 3:0  | Select the type of received packets to count at PKT_CNT register               | 0x0: None<br>0x1: VIDEO<br>0x2: Reserved<br>0x3: INFO Frame<br>0x4: SPI<br>0x5: I <sup>2</sup> C<br>0x6: UART<br>0x7: GPIO<br>0x8: Reserved<br>0x9: Reserved<br>0xA: Reserved<br>0xB: Reserved<br>0xC: Reserved<br>0xD: Reserved<br>0xE: All<br>0xF: Unknown and packets with error |

**GPIOA (0x5030)**

For GMSL Link B

| BIT         | 7 | 6 | 5                  | 4 | 3 | 2 | 1 | 0 |
|-------------|---|---|--------------------|---|---|---|---|---|
| Field       | – | – | GPIO_FWD_CDLY[5:0] |   |   |   |   |   |
| Reset       | – | – | 0b000001           |   |   |   |   |   |
| Access Type | – | – | Write, Read        |   |   |   |   |   |

| BITFIELD      | BITS | DESCRIPTION   | DECODE  |
|---------------|------|---|---|
| GPIO_FWD_CDLY | 5:0  | <p>Compensation delay multiplier for the forward direction. For Link B.</p> <p>This must be the same value as GPIO_FWD_CDLY of the chip on the other side of the link.</p> <p>Total delay is the (value + 1) multiplied by 1.7µs. Default delay is 3.4µs.</p> | 0bXXXXXX: Forward compensation delay multiplier value |

**GPIOB (0x5031)**

For GMSL Link B

| BIT         | 7                 | 6 | 5                  | 4 | 3 | 2 | 1 | 0 |
|-------------|-------------------|---|--------------------|---|---|---|---|---|
| Field       | GPIO_TX_WNDW[1:0] |   | GPIO_REV_CDLY[5:0] |   |   |   |   |   |
| Reset       | 0b10              |   | 0b001000           |   |   |   |   |   |
| Access Type | Write, Read       |   | Write, Read        |   |   |   |   |   |

| BITFIELD      | BITS | DESCRIPTION   | DECODE   |
|---------------|------|---|--|
| GPIO_TX_WNDW  | 7:6  | Wait time after a GPIO transition to create a packet. For Link B.<br><br>This allows grouping transitions of different GPIO inputs in a single packet and so increases GPIO bandwidth usage efficiency.   | 0b00: Disabled<br>0b01: 200ns<br>0b10: 500ns<br>0b11: 1000ns |
| GPIO_REV_CDLY | 5:0  | Compensation delay multiplier for the reverse direction. For Link B.<br><br>This must be the same value as GPIO_REV_CDLY of the chip on the other side of the link.<br><br>Total delay is the (value + 1) multiplied by 1.7µs. Default delay is 15.3µs. | 0bXXXXXX: Reverse compensation delay multiplier value        |

**RX0 (0x5050)**

| BIT         | 7           | 6 | 5 | 4 | 3 | 2 | 1              | 0 |
|-------------|-------------|---|---|---|---|---|----------------|---|
| Field       | RX_CRC_EN_B | – | – | – | – | – | STR_SEL_B[1:0] |   |
| Reset       | 0b0         | – | – | – | – | – | 0b00           |   |
| Access Type | Write, Read | – | – | – | – | – | Write, Read    |   |

| BITFIELD    | BITS | DESCRIPTION   | DECODE  |
|-------------|------|---|---|
| RX_CRC_EN_B | 7    | When set, indicates that packets received at this port have appended CRC and CRC checking should be performed at each packet. | 0b0: No CRC on received packets<br>0b1: Received packets have CRC and checking is enabled |
| STR_SEL_B   | 1:0  | Reserved. Do not use (legacy). Use register 0x161 VIDEO_PIPE_SEL instead.   |   |

**RX0 (0x5051)**

| BIT | 7 | 6 | 5 | 4 | 3 | 2 | 1 | 0 |
|-----|---|---|---|---|---|---|---|---|
|-----|---|---|---|---|---|---|---|---|

|                    |             |   |   |   |   |   |                |
|--------------------|-------------|---|---|---|---|---|----------------|
| <b>Field</b>       | RX_CRC_EN_B | – | – | – | – | – | STR_SEL_B[1:0] |
| <b>Reset</b>       | 0b0         | – | – | – | – | – | 0b01           |
| <b>Access Type</b> | Write, Read | – | – | – | – | – | Write, Read    |

| BITFIELD    | BITS | DESCRIPTION   | DECODE  |
|-------------|------|---|---|
| RX_CRC_EN_B | 7    | When set, indicates that packets received at this port have appended CRC and CRC checking should be performed at each packet. | 0b0: No CRC on received packets<br>0b1: Received packets have CRC and checking is enabled |
| STR_SEL_B   | 1:0  | Reserved. Do not use (legacy). Use register 0x161 VIDEO_PIPE_SEL instead.   |   |

**RX0 (0x5052)**

|                    |             |          |          |          |          |          |                |          |
|--------------------|-------------|----------|----------|----------|----------|----------|----------------|----------|
| <b>BIT</b>         | <b>7</b>    | <b>6</b> | <b>5</b> | <b>4</b> | <b>3</b> | <b>2</b> | <b>1</b>       | <b>0</b> |
| <b>Field</b>       | RX_CRC_EN_B | –        | –        | –        | –        | –        | STR_SEL_B[1:0] |          |
| <b>Reset</b>       | 0b0         | –        | –        | –        | –        | –        | 0b10           |          |
| <b>Access Type</b> | Write, Read | –        | –        | –        | –        | –        | Write, Read    |          |

| BITFIELD    | BITS | DESCRIPTION   | DECODE  |
|-------------|------|---|---|
| RX_CRC_EN_B | 7    | When set, indicates that packets received at this port have appended CRC and CRC checking should be performed at each packet. | 0b0: No CRC on received packets<br>0b1: Received packets have CRC and checking is enabled |
| STR_SEL_B   | 1:0  | Reserved. Do not use (legacy). Use register 0x161 VIDEO_PIPE_SEL instead.   |   |

**RX0 (0x5053)**

|                    |             |          |          |          |          |          |                |          |
|--------------------|-------------|----------|----------|----------|----------|----------|----------------|----------|
| <b>BIT</b>         | <b>7</b>    | <b>6</b> | <b>5</b> | <b>4</b> | <b>3</b> | <b>2</b> | <b>1</b>       | <b>0</b> |
| <b>Field</b>       | RX_CRC_EN_B | –        | –        | –        | –        | –        | STR_SEL_B[1:0] |          |
| <b>Reset</b>       | 0b0         | –        | –        | –        | –        | –        | 0b11           |          |
| <b>Access Type</b> | Write, Read | –        | –        | –        | –        | –        | Write, Read    |          |

| BITFIELD    | BITS | DESCRIPTION   | DECODE  |
|-------------|------|---|---|
| RX_CRC_EN_B | 7    | When set, indicates that packets received at this port have appended CRC and CRC checking should be performed at each packet. | 0b0: No CRC on received packets<br>0b1: Received packets have CRC and checking is enabled |

| BITFIELD  | BITS | DESCRIPTION   | DECODE |
|-----------|------|---|--------|
| STR_SEL_B | 1:0  | Reserved. Do not use (legacy). Use register 0x161 VIDEO_PIPE_SEL instead. |        |

**TR0 (0x5060)**

| BIT         | 7           | 6           | 5 | 4 | 3               | 2 | 1               | 0 |
|-------------|-------------|-------------|---|---|-----------------|---|-----------------|---|
| Field       | TX_CRC_EN_B | RX_CRC_EN_B | – | – | PRIO_VAL_B[1:0] |   | PRIO_CFG_B[1:0] |   |
| Reset       | 0b1         | 0b1         | – | – | 0b00            |   | 0b00            |   |
| Access Type | Write, Read | Write, Read | – | – | Write, Read     |   | Write, Read     |   |

| BITFIELD    | BITS | DESCRIPTION   | DECODE   |
|-------------|------|---|--|
| TX_CRC_EN_B | 7    | When set, calculate and append CRC to each packet transmitted from this port.   | 0b0: Transmit CRC disabled<br>0b1: Transmit CRC enabled  |
| RX_CRC_EN_B | 6    | When set, indicates that packets received at this port have appended CRC and CRC checking should be performed at each packet. | 0b0: Receive CRC disabled<br>0b1: Receive CRC enabled  |
| PRIO_VAL_B  | 3:2  | Sets the priority for this channel's packet requests  | 0b00: Low priority<br>0b01: Normal priority<br>0b10: High priority<br>0b11: Urgent priority  |
| PRIO_CFG_B  | 1:0  | Adjust the priority used for this channel   | 0b00: Current channel priority is used<br>0b01: Increase current channel priority<br>0b10: Decrease current channel priority<br>0b11: Reset to channel PRIO_VAL[1:0] setting |

**TR1 (0x5061)**

| BIT         | 7              | 6 | 5             | 4 | 3 | 2 | 1 | 0 |
|-------------|----------------|---|---------------|---|---|---|---|---|
| Field       | BW_MULT_B[1:0] |   | BW_VAL_B[5:0] |   |   |   |   |   |
| Reset       | 0b10           |   | 0b110000      |   |   |   |   |   |
| Access Type | Write, Read    |   | Write, Read   |   |   |   |   |   |

| BITFIELD  | BITS | DESCRIPTION  | DECODE   |
|-----------|------|--|--|
| BW_MULT_B | 7:6  | Channel bandwidth-allocation multiplication factor   | 0b00: Multiply BW_VAL by 1<br>0b01: Multiply BW_VAL by 4<br>0b10: Multiply BW_VAL by 16<br>0b11: Multiply BW_VAL by 16 |
| BW_VAL_B  | 5:0  | Channel bandwidth-allocation base. Used to calculate percentage of total link bandwidth used for this port.<br><br>Fair bandwidth use ratio = BW_VAL x BW_MULT/10 as a percentage of total link bandwidth. | 0bXXXXXX: Channel base BW value  |

**TR3 (0x5063)**

|                    |          |          |          |          |          |                  |          |          |
|--------------------|----------|----------|----------|----------|----------|------------------|----------|----------|
| <b>BIT</b>         | <b>7</b> | <b>6</b> | <b>5</b> | <b>4</b> | <b>3</b> | <b>2</b>         | <b>1</b> | <b>0</b> |
| <b>Field</b>       | –        | –        | –        | –        | –        | TX_SRC_ID_B[2:0] |          |          |
| <b>Reset</b>       | –        | –        | –        | –        | –        | 0b000            |          |          |
| <b>Access Type</b> | –        | –        | –        | –        | –        | Write, Read      |          |          |

| <b>BITFIELD</b> | <b>BITS</b> | <b>DESCRIPTION</b>  | <b>DECODE</b>                                  |
|-----------------|-------------|---|--|
| TX_SRC_ID_B     | 2:0         | Source identifier used in packets transmitted from this channel.<br><br>Default value is based on the device address set by the CFG0 pin. | 0bXXX: Source ID for packets from this channel |

**TR4 (0x5064)**

|                    |                   |          |          |          |          |          |          |          |
|--------------------|-------------------|----------|----------|----------|----------|----------|----------|----------|
| <b>BIT</b>         | <b>7</b>          | <b>6</b> | <b>5</b> | <b>4</b> | <b>3</b> | <b>2</b> | <b>1</b> | <b>0</b> |
| <b>Field</b>       | RX_SRC_SEL_B[7:0] |          |          |          |          |          |          |          |
| <b>Reset</b>       | 0xFF              |          |          |          |          |          |          |          |
| <b>Access Type</b> | Write, Read       |          |          |          |          |          |          |          |

| <b>BITFIELD</b> | <b>BITS</b> | <b>DESCRIPTION</b>   | <b>DECODE</b>   |
|-----------------|-------------|--|---|
| RX_SRC_SEL_B    | 7:0         | Receive packets from selected sources.<br><br>Each bit indicates if packets with that source ID should be received or not. This is a one-hot encoding.<br><br>For example, when SRC_SEL = 00001001, then packets with source ID equal to 0 and 3 are received. | 0x00: No packets received<br>0x01: Packets from source ID 0 received<br>0x02: Packets from source ID 1 received<br>0x03: Packets from source ID 0 and 1 received<br>0x04: Packets from source ID 2 received<br>...<br>...<br>0xFF: Packets from all source IDs received |

**TR0 (0x5070, 0x5080, 0x5088)**

|                    |             |             |          |          |                 |          |                 |          |
|--------------------|-------------|-------------|----------|----------|-----------------|----------|-----------------|----------|
| <b>BIT</b>         | <b>7</b>    | <b>6</b>    | <b>5</b> | <b>4</b> | <b>3</b>        | <b>2</b> | <b>1</b>        | <b>0</b> |
| <b>Field</b>       | TX_CRC_EN_B | RX_CRC_EN_B | –        | –        | PRIO_VAL_B[1:0] |          | PRIO_CFG_B[1:0] |          |
| <b>Reset</b>       | 0b1         | 0b1         | –        | –        | 0b00            |          | 0b00            |          |
| <b>Access Type</b> | Write, Read | Write, Read | –        | –        | Write, Read     |          | Write, Read     |          |

| BITFIELD    | BITS | DESCRIPTION   | DECODE   |
|-------------|------|---|--|
| TX_CRC_EN_B | 7    | When set, calculate and append CRC to each packet transmitted from this port.   | 0b0: Transmit CRC disabled<br>0b1: Transmit CRC enabled  |
| RX_CRC_EN_B | 6    | When set, indicates that packets received at this port have appended CRC and CRC checking should be performed at each packet. | 0b0: Receive CRC disabled<br>0b1: Receive CRC enabled  |
| PRIO_VAL_B  | 3:2  | Sets the priority for this channel's packet requests  | 0b00: Low priority<br>0b01: Normal priority<br>0b10: High priority<br>0b11: Urgent priority  |
| PRIO_CFG_B  | 1:0  | Adjust the priority used for this channel   | 0b00: Current channel priority is used<br>0b01: Increase current channel priority<br>0b10: Decrease current channel priority<br>0b11: Reset to channel PRIO_VAL[1:0] setting |

**TR1 (0x5071, 0x5081, 0x5089)**

| BIT         | 7              | 6 | 5             | 4 | 3 | 2 | 1 | 0 |
|-------------|----------------|---|---------------|---|---|---|---|---|
| Field       | BW_MULT_B[1:0] |   | BW_VAL_B[5:0] |   |   |   |   |   |
| Reset       | 0b10           |   | 0b110000      |   |   |   |   |   |
| Access Type | Write, Read    |   | Write, Read   |   |   |   |   |   |

| BITFIELD  | BITS | DESCRIPTION  | DECODE   |
|-----------|------|--|--|
| BW_MULT_B | 7:6  | Channel bandwidth-allocation multiplication factor   | 0b00: Multiply BW_VAL by 1<br>0b01: Multiply BW_VAL by 4<br>0b10: Multiply BW_VAL by 16<br>0b11: Multiply BW_VAL by 16 |
| BW_VAL_B  | 5:0  | Channel bandwidth-allocation base. Used to calculate percentage of total link bandwidth used for this port.<br><br>Fair bandwidth use ratio = BW_VAL x BW_MULT/10 as a percentage of total link bandwidth. | 0bXXXXXX: Channel base BW value  |

**TR3 (0x5073, 0x5083, 0x508B)**

| BIT         | 7 | 6 | 5 | 4 | 3 | 2                | 1 | 0 |
|-------------|---|---|---|---|---|------------------|---|---|
| Field       | - | - | - | - | - | TX_SRC_ID_B[2:0] |   |   |
| Reset       | - | - | - | - | - | 0b000            |   |   |
| Access Type | - | - | - | - | - | Write, Read      |   |   |

| BITFIELD    | BITS | DESCRIPTION   | DECODE   |
|-------------|------|---|--|
| TX_SRC_ID_B | 2:0  | Source identifier used in packets transmitted from this channel.<br><br>Default value is based on the device address set by the CFG0 pin. | 0bXXX: Source ID for packets from this channel |

**TR4 (0x5074, 0x5084, 0x508C)**

| BIT         | 7                 | 6 | 5 | 4 | 3 | 2 | 1 | 0 |
|-------------|-------------------|---|---|---|---|---|---|---|
| Field       | RX_SRC_SEL_B[7:0] |   |   |   |   |   |   |   |
| Reset       | 0xFF              |   |   |   |   |   |   |   |
| Access Type | Write, Read       |   |   |   |   |   |   |   |

| BITFIELD     | BITS | DESCRIPTION  | DECODE  |
|--------------|------|--|---|
| RX_SRC_SEL_B | 7:0  | Receive packets from selected sources.<br><br>Each bit indicates if packets with that source ID should be received or not. This is a one-hot encoding.<br><br>For example, when SRC_SEL = 00001001, then packets with source ID equal to 0 and 3 are received. | 0x00: No packets received<br>0x01: Packets from source ID 0 received<br>0x02: Packets from source ID 1 received<br>0x03: Packets from source ID 0 and 1 received<br>0x04: Packets from source ID 2 received<br>...<br>...<br>0xFF: Packets from all source IDs received |

**ARQ0 (0x5075, 0x5085, 0x508D)**

| BIT         | 7 | 6 | 5 | 4 | 3           | 2                  | 1 | 0 |
|-------------|---|---|---|---|-------------|--------------------|---|---|
| Field       | - | - | - | - | EN_B        | DIS_DBL_ACK_RETX_B | - | - |
| Reset       | - | - | - | - | 0b1         | 0b0                | - | - |
| Access Type | - | - | - | - | Write, Read | Write, Read        | - | - |

| BITFIELD           | BITS | DESCRIPTION  | DECODE                                |
|--------------------|------|--|---------------------------------------|
| EN_B               | 3    | Enable ARQ   | 0b0: ARQ disabled<br>0b1: ARQ enabled |
| DIS_DBL_ACK_RETX_B | 2    | Disable retransmission due to receiving same acknowledge twice | 0b0: Enabled<br>0b1: Disabled         |

**ARQ1 (0x5076, 0x5086, 0x508E)**

| BIT | 7 | 6 | 5 | 4 | 3 | 2 | 1 | 0 |
|-----|---|---|---|---|---|---|---|---|
|-----|---|---|---|---|---|---|---|---|

|             |   |   |   |   |   |   |                  |              |
|-------------|---|---|---|---|---|---|------------------|--------------|
| Field       | - | - | - | - | - | - | MAX_RT_ERR_OEN_B | RT_CNT_OEN_B |
| Reset       | - | - | - | - | - | - | 0b1              | 0b0          |
| Access Type | - | - | - | - | - | - | Write, Read      | Write, Read  |

| BITFIELD         | BITS | DESCRIPTION   | DECODE  |
|------------------|------|---|---|
| MAX_RT_ERR_OEN_B | 1    | Enable reporting of ARQ maximum retransmission limit errors (MAX_RT_ERR) for this channel at ERRB pin.  | 0b0: ARQ maximum retransmission limit errors reporting at ERRB pin disabled<br>0b1: ARQ maximum retransmission limit errors reporting at ERRB pin enabled |
| RT_CNT_OEN_B     | 0    | Enable reporting of ARQ retransmission event for this channel at ERRB pin.<br><br>When enabled, ERRB is asserted when RT_CNT of this channel is greater than 0. | 0b0: ARQ retransmission count reporting at ERRB pin disabled<br>0b1: ARQ retransmission count reporting at ERRB pin enabled                               |

**ARQ2 (0x5077, 0x5087, 0x508F)**

|             |                 |                 |   |   |   |   |   |   |
|-------------|-----------------|-----------------|---|---|---|---|---|---|
| BIT         | 7               | 6               | 5 | 4 | 3 | 2 | 1 | 0 |
| Field       | MAX_RT_ERR_B    | RT_CNT_B[6:0]   |   |   |   |   |   |   |
| Reset       | 0b0             | 0b0000000       |   |   |   |   |   |   |
| Access Type | Read Clears All | Read Clears All |   |   |   |   |   |   |

| BITFIELD     | BITS | DESCRIPTION  | DECODE   |
|--------------|------|--|--|
| MAX_RT_ERR_B | 7    | Reached maximum retransmission limit (MAX_RT) for one packet in this channel | 0b0: Maximum retransmission limit not reached<br>0b1: Maximum retransmission limit reached |
| RT_CNT_B     | 6:0  | Total retransmission count in this channel                                   | 0xXX: Count of retransmissions for this channel  |

**TR0 (0x5078)**

|             |             |             |   |   |                 |   |                 |   |
|-------------|-------------|-------------|---|---|-----------------|---|-----------------|---|
| BIT         | 7           | 6           | 5 | 4 | 3               | 2 | 1               | 0 |
| Field       | TX_CRC_EN_B | RX_CRC_EN_B | - | - | PRIO_VAL_B[1:0] |   | PRIO_CFG_B[1:0] |   |
| Reset       | 0b1         | 0b1         | - | - | 0b00            |   | 0b00            |   |
| Access Type | Write, Read | Write, Read | - | - | Write, Read     |   | Write, Read     |   |

| BITFIELD    | BITS | DESCRIPTION  | DECODE  |
|-------------|------|--|---|
| TX_CRC_EN_B | 7    | When set, calculate and append CRC to each packet transmitted from this port | 0b0: Transmit CRC disabled<br>0b1: Transmit CRC enabled |

| BITFIELD    | BITS | DESCRIPTION   | DECODE   |
|-------------|------|---|--|
| RX_CRC_EN_B | 6    | When set, indicates that packets received at this port have appended CRC and CRC checking should be performed at each packet. | 0b0: Receive CRC disabled<br>0b1: Receive CRC enabled  |
| PRIO_VAL_B  | 3:2  | Sets the priority for this channel's packet requests  | 0b00: Low priority<br>0b01: Normal priority<br>0b10: High priority<br>0b11: Urgent priority  |
| PRIO_CFG_B  | 1:0  | Adjust the priority used for this channel   | 0b00: Current channel priority is used<br>0b01: Increase current channel priority<br>0b10: Decrease current channel priority<br>0b11: Reset to channel PRIO_VAL[1:0] setting |

**TR1 (0x5079)**

| BIT         | 7              | 6 | 5             | 4 | 3 | 2 | 1 | 0 |
|-------------|----------------|---|---------------|---|---|---|---|---|
| Field       | BW_MULT_B[1:0] |   | BW_VAL_B[5:0] |   |   |   |   |   |
| Reset       | 0b10           |   | 0b110000      |   |   |   |   |   |
| Access Type | Write, Read    |   | Write, Read   |   |   |   |   |   |

| BITFIELD  | BITS | DESCRIPTION   | DECODE   |
|-----------|------|---|--|
| BW_MULT_B | 7:6  | Channel bandwidth-allocation multiplication factor  | 0b00: Multiply BW_VAL by 1<br>0b01: Multiply BW_VAL by 4<br>0b10: Multiply BW_VAL by 16<br>0b11: Multiply BW_VAL by 16 |
| BW_VAL_B  | 5:0  | Channel bandwidth-allocation base. Used to calculate percentage of total link bandwidth used for this port.<br><br>Fair bandwidth use ratio = $BW\_VAL \times BW\_MULT/10$ as a percentage of total link bandwidth. | 0bXXXXXX: Channel base BW value  |

**TR3 (0x507B)**

| BIT         | 7 | 6 | 5 | 4 | 3 | 2                | 1 | 0 |
|-------------|---|---|---|---|---|------------------|---|---|
| Field       | – | – | – | – | – | TX_SRC_ID_B[2:0] |   |   |
| Reset       | – | – | – | – | – | 0b000            |   |   |
| Access Type | – | – | – | – | – | Write, Read      |   |   |

| BITFIELD    | BITS | DESCRIPTION  | DECODE   |
|-------------|------|--|--|
| TX_SRC_ID_B | 2:0  | Source identifier used in packets transmitted from this channel. | 0bXXX: Source ID for packets from this channel |

| BITFIELD | BITS | DESCRIPTION   | DECODE |
|----------|------|---|--------|
|          |      | Default value is based on the device address set by the CFG0 pin. |        |

**TR4 (0x507C)**

| BIT         | 7                 | 6 | 5 | 4 | 3 | 2 | 1 | 0 |
|-------------|-------------------|---|---|---|---|---|---|---|
| Field       | RX_SRC_SEL_B[7:0] |   |   |   |   |   |   |   |
| Reset       | 0xFF              |   |   |   |   |   |   |   |
| Access Type | Write, Read       |   |   |   |   |   |   |   |

| BITFIELD     | BITS | DESCRIPTION   | DECODE   |
|--------------|------|---|--|
| RX_SRC_SEL_B | 7:0  | <p>Receive packets from selected sources.</p> <p>Each bit indicates if packets with that source ID should be received or not. This is a one-hot encoding.</p> <p>For example, when SRC_SEL = 00001001, then packets with source ID equal to 0 and 3 are received.</p> | <p>0x00: No packets received</p> <p>0x01: Packets from source ID 0 received</p> <p>0x02: Packets from source ID 1 received</p> <p>0x03: Packets from source ID 0 and 1 received</p> <p>0x04: Packets from source ID 2 received</p> <p>...</p> <p>...</p> <p>0xFF: Packets from all source IDs received</p> |

**ARQ0 (0x507D)**

| BIT         | 7 | 6 | 5 | 4 | 3           | 2                  | 1 | 0 |
|-------------|---|---|---|---|-------------|--------------------|---|---|
| Field       | - | - | - | - | EN_B        | DIS_DBL_ACK_RETX_B | - | - |
| Reset       | - | - | - | - | 0b1         | 0b0                | - | - |
| Access Type | - | - | - | - | Write, Read | Write, Read        | - | - |

| BITFIELD           | BITS | DESCRIPTION  | DECODE                                |
|--------------------|------|--|---------------------------------------|
| EN_B               | 3    | Enable ARQ   | 0b0: ARQ disabled<br>0b1: ARQ enabled |
| DIS_DBL_ACK_RETX_B | 2    | Disable retransmission due to receiving same acknowledge twice | 0b0: Enabled<br>0b1: Disabled         |

**ARQ1 (0x507E)**

| BIT   | 7 | 6 | 5 | 4 | 3 | 2 | 1                | 0            |
|-------|---|---|---|---|---|---|------------------|--------------|
| Field | - | - | - | - | - | - | MAX_RT_ERR_OEN_B | RT_CNT_OEN_B |
| Reset | - | - | - | - | - | - | 0b1              | 0b0          |

|             |   |   |   |   |   |   |             |             |
|-------------|---|---|---|---|---|---|-------------|-------------|
| Access Type | - | - | - | - | - | - | Write, Read | Write, Read |
|-------------|---|---|---|---|---|---|-------------|-------------|

| BITFIELD         | BITS | DESCRIPTION   | DECODE  |
|------------------|------|---|---|
| MAX_RT_ERR_OEN_B | 1    | Enable reporting of ARQ maximum retransmission limit errors (MAX_RT_ERR) for this channel at ERRB pin.  | 0b0: ARQ maximum retransmit limit errors reporting at ERRB pin disabled<br>0b1: ARQ maximum retransmit limit errors reporting at ERRB pin enabled |
| RT_CNT_OEN_B     | 0    | Enable reporting of ARQ retransmission event for this channel at ERRB pin.<br><br>When enabled, ERRB is asserted when RT_CNT of this channel is greater than 0. | 0b0: ARQ retransmission count reporting at ERRB pin disabled<br>0b1: ARQ retransmission count reporting at ERRB pin enabled                       |

**ARQ2 (0x507F)**

| BIT         | 7               | 6               | 5 | 4 | 3 | 2 | 1 | 0 |
|-------------|-----------------|-----------------|---|---|---|---|---|---|
| Field       | MAX_RT_ERR_B    | RT_CNT_B[6:0]   |   |   |   |   |   |   |
| Reset       | 0b0             | 0b0000000       |   |   |   |   |   |   |
| Access Type | Read Clears All | Read Clears All |   |   |   |   |   |   |

| BITFIELD     | BITS | DESCRIPTION  | DECODE   |
|--------------|------|--|--|
| MAX_RT_ERR_B | 7    | Reached maximum retransmission limit (MAX_RT) for one packet in this channel | 0b0: Maximum retransmission limit not reached<br>0b1: Maximum retransmission limit reached |
| RT_CNT_B     | 6:0  | Total retransmission count in this channel                                   | 0xXX: Count of retransmissions for this channel  |

**GPIO A (0x52B0)**

GPIO 0

| BIT         | 7 | 6 | 5            | 4 | 3 | 2            | 1            | 0 |
|-------------|---|---|--------------|---|---|--------------|--------------|---|
| Field       | - | - | TX_COMP_EN_B | - | - | GPIO_RX_EN_B | GPIO_TX_EN_B | - |
| Reset       | - | - | 0b0          | - | - | 0b0          | 0b1          | - |
| Access Type | - | - | Write, Read  | - | - | Write, Read  | Write, Read  | - |

| BITFIELD     | BITS | DESCRIPTION   | DECODE  |
|--------------|------|---|---|
| TX_COMP_EN_B | 5    | Enables jitter minimization compensation  | 0b0: Jitter compensation disabled<br>0b1: Jitter compensation enabled                                 |
| GPIO_RX_EN_B | 2    | GPIO out source control.<br>Set to 1 to receive GPIO value from GMSL link. Set GPIO_OUT_DIS to 0 to output the received value on the local MFP. | 0b0: This GPIO source disabled for GMSL reception<br>0b1: This GPIO source enabled for GMSL reception |

| BITFIELD     | BITS | DESCRIPTION   | DECODE  |
|--------------|------|---|---|
| GPIO_TX_EN_B | 1    | GPIO Tx source control.<br>Set to 1 to transmit the local MFP input value across the GMSL link. | 0b0: This GPIO source disabled for GMSL transmission<br>0b1: This GPIO source enabled for GMSL transmission |

**GPIO B (0x52B1)**

GPIO 0

| BIT         | 7 | 6 | 5 | 4                 | 3 | 2 | 1 | 0 |
|-------------|---|---|---|-------------------|---|---|---|---|
| Field       | – | – | – | GPIO_TX_ID_B[4:0] |   |   |   |   |
| Reset       | – | – | – | 0b00000           |   |   |   |   |
| Access Type | – | – | – | Write, Read       |   |   |   |   |

| BITFIELD     | BITS | DESCRIPTION                        | DECODE                         |
|--------------|------|------------------------------------|--------------------------------|
| GPIO_TX_ID_B | 4:0  | GPIO ID for pin while transmitting | 0bXXXXX: This GPIO transmit ID |

**GPIO C (0x52B2)**

GPIO 0

| BIT         | 7 | 6             | 5 | 4                 | 3 | 2 | 1 | 0 |
|-------------|---|---------------|---|-------------------|---|---|---|---|
| Field       | – | GPIO_RECVED_B | – | GPIO_RX_ID_B[4:0] |   |   |   |   |
| Reset       | – | 0b1           | – | 0b00000           |   |   |   |   |
| Access Type | – | Write, Read   | – | Write, Read       |   |   |   |   |

| BITFIELD      | BITS | DESCRIPTION                                   | DECODE                        |
|---------------|------|---|-------------------------------|
| GPIO_RECVED_B | 6    | Received GPIO value from across the GMSL link |                               |
| GPIO_RX_ID_B  | 4:0  | GPIO ID for pin while receiving               | 0bXXXXX: This GPIO receive ID |

**GPIO A (0x52B3)**

GPIO 1

| BIT         | 7 | 6 | 5            | 4 | 3 | 2            | 1            | 0 |
|-------------|---|---|--------------|---|---|--------------|--------------|---|
| Field       | – | – | TX_COMP_EN_B | – | – | GPIO_RX_EN_B | GPIO_TX_EN_B | – |
| Reset       | – | – | 0b0          | – | – | 0b0          | 0b0          | – |
| Access Type | – | – | Write, Read  | – | – | Write, Read  | Write, Read  | – |

| BITFIELD     | BITS | DESCRIPTION   | DECODE  |
|--------------|------|---|---|
| TX_COMP_EN_B | 5    | Enables jitter minimization compensation  | 0b0: Jitter compensation disabled<br>0b1: Jitter compensation enabled                                       |
| GPIO_RX_EN_B | 2    | GPIO out source control.<br>Set to 1 to receive GPIO value from GMSL link. Set GPIO_OUT_DIS to 0 to output the received value on the local MFP. | 0b0: This GPIO source disabled for GMSL reception<br>0b1: This GPIO source enabled for GMSL reception       |
| GPIO_TX_EN_B | 1    | GPIO Tx source control.<br>Set to 1 to transmit the local MFP input value across the GMSL link.   | 0b0: This GPIO source disabled for GMSL transmission<br>0b1: This GPIO source enabled for GMSL transmission |

**GPIO B (0x52B4)**

GPIO 1

| BIT         | 7 | 6 | 5 | 4                 | 3 | 2 | 1 | 0 |
|-------------|---|---|---|-------------------|---|---|---|---|
| Field       | – | – | – | GPIO_TX_ID_B[4:0] |   |   |   |   |
| Reset       | – | – | – | 0b00001           |   |   |   |   |
| Access Type | – | – | – | Write, Read       |   |   |   |   |

| BITFIELD     | BITS | DESCRIPTION                        | DECODE                         |
|--------------|------|------------------------------------|--------------------------------|
| GPIO_TX_ID_B | 4:0  | GPIO ID for pin while transmitting | 0bXXXXX: This GPIO transmit ID |

**GPIO C (0x52B5)**

GPIO 1

| BIT         | 7 | 6 | 5 | 4                 | 3 | 2 | 1 | 0 |
|-------------|---|---|---|-------------------|---|---|---|---|
| Field       | – | – | – | GPIO_RX_ID_B[4:0] |   |   |   |   |
| Reset       | – | – | – | 0b00001           |   |   |   |   |
| Access Type | – | – | – | Write, Read       |   |   |   |   |

| BITFIELD     | BITS | DESCRIPTION                     | DECODE                        |
|--------------|------|---------------------------------|-------------------------------|
| GPIO_RX_ID_B | 4:0  | GPIO ID for pin while receiving | 0bXXXXX: This GPIO receive ID |

**GPIO A (0x52B6)**

GPIO 2

| BIT | 7 | 6 | 5 | 4 | 3 | 2 | 1 | 0 |
|-----|---|---|---|---|---|---|---|---|
|-----|---|---|---|---|---|---|---|---|

|             |   |   |              |   |   |              |              |   |
|-------------|---|---|--------------|---|---|--------------|--------------|---|
| Field       | – | – | TX_COMP_EN_B | – | – | GPIO_RX_EN_B | GPIO_TX_EN_B | – |
| Reset       | – | – | 0b0          | – | – | 0b0          | 0b0          | – |
| Access Type | – | – | Write, Read  | – | – | Write, Read  | Write, Read  | – |

| BITFIELD     | BITS | DESCRIPTION  | DECODE  |
|--------------|------|--|---|
| TX_COMP_EN_B | 5    | Enables jitter minimization compensation   | 0b0: Jitter compensation disabled<br>0b1: Jitter compensation enabled                                       |
| GPIO_RX_EN_B | 2    | GPIO out source control. Set to 1 to receive GPIO value from GMSL link. Set GPIO_OUT_DIS to 0 to output the received value on the local MFP. | 0b0: This GPIO source disabled for GMSL reception<br>0b1: This GPIO source enabled for GMSL reception       |
| GPIO_TX_EN_B | 1    | GPIO Tx source control. Set to 1 to transmit the local MFP input value across the GMSL link.   | 0b0: This GPIO source disabled for GMSL transmission<br>0b1: This GPIO source enabled for GMSL transmission |

**GPIO B (0x52B7)**

GPIO 2

|             |   |   |   |                   |   |   |   |   |
|-------------|---|---|---|-------------------|---|---|---|---|
| BIT         | 7 | 6 | 5 | 4                 | 3 | 2 | 1 | 0 |
| Field       | – | – | – | GPIO_TX_ID_B[4:0] |   |   |   |   |
| Reset       | – | – | – | 0b00010           |   |   |   |   |
| Access Type | – | – | – | Write, Read       |   |   |   |   |

| BITFIELD     | BITS | DESCRIPTION                        | DECODE                         |
|--------------|------|------------------------------------|--------------------------------|
| GPIO_TX_ID_B | 4:0  | GPIO ID for pin while transmitting | 0bXXXXX: This GPIO transmit ID |

**GPIO C (0x52B8)**

GPIO 2

|             |   |   |   |                   |   |   |   |   |
|-------------|---|---|---|-------------------|---|---|---|---|
| BIT         | 7 | 6 | 5 | 4                 | 3 | 2 | 1 | 0 |
| Field       | – | – | – | GPIO_RX_ID_B[4:0] |   |   |   |   |
| Reset       | – | – | – | 0b00010           |   |   |   |   |
| Access Type | – | – | – | Write, Read       |   |   |   |   |

| BITFIELD     | BITS | DESCRIPTION                     | DECODE                        |
|--------------|------|---------------------------------|-------------------------------|
| GPIO_RX_ID_B | 4:0  | GPIO ID for pin while receiving | 0bXXXXX: This GPIO receive ID |

**GPIO A (0x52B9)**

GPIO 3

| BIT         | 7 | 6 | 5            | 4 | 3 | 2            | 1            | 0 |
|-------------|---|---|--------------|---|---|--------------|--------------|---|
| Field       | – | – | TX_COMP_EN_B | – | – | GPIO_RX_EN_B | GPIO_TX_EN_B | – |
| Reset       | – | – | 0b0          | – | – | 0b0          | 0b0          | – |
| Access Type | – | – | Write, Read  | – | – | Write, Read  | Write, Read  | – |

| BITFIELD     | BITS | DESCRIPTION   | DECODE  |
|--------------|------|---|---|
| TX_COMP_EN_B | 5    | Enables jitter minimization compensation  | 0b0: Jitter compensation disabled<br>0b1: Jitter compensation enabled                                       |
| GPIO_RX_EN_B | 2    | GPIO out source control.<br>Set to 1 to receive GPIO value from GMSL link. Set GPIO_OUT_DIS to 0 to output the received value on the local MFP. | 0b0: This GPIO source disabled for GMSL reception<br>0b1: This GPIO source enabled for GMSL reception       |
| GPIO_TX_EN_B | 1    | GPIO Tx source control.<br>Set to 1 to transmit the local MFP input value across the GMSL link.   | 0b0: This GPIO source disabled for GMSL transmission<br>0b1: This GPIO source enabled for GMSL transmission |

**GPIO B (0x52BA)**

GPIO 3

| BIT         | 7 | 6 | 5 | 4                 | 3 | 2 | 1 | 0 |
|-------------|---|---|---|-------------------|---|---|---|---|
| Field       | – | – | – | GPIO_TX_ID_B[4:0] |   |   |   |   |
| Reset       | – | – | – | 0b00011           |   |   |   |   |
| Access Type | – | – | – | Write, Read       |   |   |   |   |

| BITFIELD     | BITS | DESCRIPTION                        | DECODE                         |
|--------------|------|------------------------------------|--------------------------------|
| GPIO_TX_ID_B | 4:0  | GPIO ID for pin while transmitting | 0bXXXXX: This GPIO transmit ID |

**GPIO C (0x52BB)**

GPIO 3

| BIT         | 7 | 6 | 5 | 4                 | 3 | 2 | 1 | 0 |
|-------------|---|---|---|-------------------|---|---|---|---|
| Field       | – | – | – | GPIO_RX_ID_B[4:0] |   |   |   |   |
| Reset       | – | – | – | 0b00011           |   |   |   |   |
| Access Type | – | – | – | Write, Read       |   |   |   |   |

| BITFIELD     | BITS | DESCRIPTION                     | DECODE                        |
|--------------|------|---------------------------------|-------------------------------|
| GPIO_RX_ID_B | 4:0  | GPIO ID for pin while receiving | 0bXXXXX: This GPIO receive ID |

**GPIO A (0x52BC)**

## GPIO 4

| BIT         | 7 | 6 | 5            | 4 | 3 | 2            | 1            | 0 |
|-------------|---|---|--------------|---|---|--------------|--------------|---|
| Field       | – | – | TX_COMP_EN_B | – | – | GPIO_RX_EN_B | GPIO_TX_EN_B | – |
| Reset       | – | – | 0b0          | – | – | 0b0          | 0b0          | – |
| Access Type | – | – | Write, Read  | – | – | Write, Read  | Write, Read  | – |

| BITFIELD     | BITS | DESCRIPTION   | DECODE  |
|--------------|------|---|---|
| TX_COMP_EN_B | 5    | Enables jitter minimization compensation  | 0b0: Jitter compensation disabled<br>0b1: Jitter compensation enabled                                       |
| GPIO_RX_EN_B | 2    | GPIO out source control.<br>Set to 1 to receive GPIO value from GMSL link. Set GPIO_OUT_DIS to 0 to output the received value on the local MFP. | 0b0: This GPIO source disabled for GMSL reception<br>0b1: This GPIO source enabled for GMSL reception       |
| GPIO_TX_EN_B | 1    | GPIO Tx source control.<br>Set to 1 to transmit the local MFP input value across the GMSL link.   | 0b0: This GPIO source disabled for GMSL transmission<br>0b1: This GPIO source enabled for GMSL transmission |

**GPIO B (0x52BD)**

## GPIO 4

| BIT         | 7 | 6 | 5 | 4                 | 3 | 2 | 1 | 0 |
|-------------|---|---|---|-------------------|---|---|---|---|
| Field       | – | – | – | GPIO_TX_ID_B[4:0] |   |   |   |   |
| Reset       | – | – | – | 0b00100           |   |   |   |   |
| Access Type | – | – | – | Write, Read       |   |   |   |   |

| BITFIELD     | BITS | DESCRIPTION                        | DECODE                         |
|--------------|------|------------------------------------|--------------------------------|
| GPIO_TX_ID_B | 4:0  | GPIO ID for pin while transmitting | 0bXXXXX: This GPIO transmit ID |

**GPIO C (0x52BE)**

## GPIO 4

| BIT   | 7 | 6 | 5 | 4                 | 3 | 2 | 1 | 0 |
|-------|---|---|---|-------------------|---|---|---|---|
| Field | – | – | – | GPIO_RX_ID_B[4:0] |   |   |   |   |

|                    |   |   |   |             |
|--------------------|---|---|---|-------------|
| <b>Reset</b>       | – | – | – | 0b00100     |
| <b>Access Type</b> | – | – | – | Write, Read |

| <b>BITFIELD</b> | <b>BITS</b> | <b>DESCRIPTION</b>              | <b>DECODE</b>                 |
|-----------------|-------------|---------------------------------|-------------------------------|
| GPIO_RX_ID_B    | 4:0         | GPIO ID for pin while receiving | 0bXXXXX: This GPIO receive ID |

**GPIO A (0x52BF)**

## GPIO 5

| <b>BIT</b>         | <b>7</b> | <b>6</b> | <b>5</b>     | <b>4</b> | <b>3</b> | <b>2</b>     | <b>1</b>     | <b>0</b> |
|--------------------|----------|----------|--------------|----------|----------|--------------|--------------|----------|
| <b>Field</b>       | –        | –        | TX_COMP_EN_B | –        | –        | GPIO_RX_EN_B | GPIO_TX_EN_B | –        |
| <b>Reset</b>       | –        | –        | 0b0          | –        | –        | 0b0          | 0b0          | –        |
| <b>Access Type</b> | –        | –        | Write, Read  | –        | –        | Write, Read  | Write, Read  | –        |

| <b>BITFIELD</b> | <b>BITS</b> | <b>DESCRIPTION</b>  | <b>DECODE</b>   |
|-----------------|-------------|---|---|
| TX_COMP_EN_B    | 5           | Enables jitter minimization compensation  | 0b0: Jitter compensation disabled<br>0b1: Jitter compensation enabled                                       |
| GPIO_RX_EN_B    | 2           | GPIO out source control.<br>Set to 1 to receive GPIO value from GMSL link. Set GPIO_OUT_DIS to 0 to output the received value on the local MFP. | 0b0: This GPIO source disabled for GMSL reception<br>0b1: This GPIO source enabled for GMSL reception       |
| GPIO_TX_EN_B    | 1           | GPIO Tx source control.<br>Set to 1 to transmit the local MFP input value across the GMSL link.   | 0b0: This GPIO source disabled for GMSL transmission<br>0b1: This GPIO source enabled for GMSL transmission |

**GPIO B (0x52C0)**

## GPIO 5

| <b>BIT</b>         | <b>7</b> | <b>6</b> | <b>5</b> | <b>4</b>          | <b>3</b> | <b>2</b> | <b>1</b> | <b>0</b> |
|--------------------|----------|----------|----------|-------------------|----------|----------|----------|----------|
| <b>Field</b>       | –        | –        | –        | GPIO_TX_ID_B[4:0] |          |          |          |          |
| <b>Reset</b>       | –        | –        | –        | 0b00101           |          |          |          |          |
| <b>Access Type</b> | –        | –        | –        | Write, Read       |          |          |          |          |

| <b>BITFIELD</b> | <b>BITS</b> | <b>DESCRIPTION</b>                 | <b>DECODE</b>                  |
|-----------------|-------------|------------------------------------|--------------------------------|
| GPIO_TX_ID_B    | 4:0         | GPIO ID for pin while transmitting | 0bXXXXX: This GPIO transmit ID |

**GPIO C (0x52C1)**

## GPIO 5

| BIT         | 7 | 6 | 5 | 4                 | 3 | 2 | 1 | 0 |
|-------------|---|---|---|-------------------|---|---|---|---|
| Field       | – | – | – | GPIO_RX_ID_B[4:0] |   |   |   |   |
| Reset       | – | – | – | 0b00101           |   |   |   |   |
| Access Type | – | – | – | Write, Read       |   |   |   |   |

| BITFIELD     | BITS | DESCRIPTION                     | DECODE                        |
|--------------|------|---------------------------------|-------------------------------|
| GPIO_RX_ID_B | 4:0  | GPIO ID for pin while receiving | 0bXXXXX: This GPIO receive ID |

### GPIO A (0x52C2)

#### GPIO 6

| BIT         | 7 | 6 | 5            | 4 | 3 | 2            | 1            | 0 |
|-------------|---|---|--------------|---|---|--------------|--------------|---|
| Field       | – | – | TX_COMP_EN_B | – | – | GPIO_RX_EN_B | GPIO_TX_EN_B | – |
| Reset       | – | – | 0b0          | – | – | 0b0          | 0b1          | – |
| Access Type | – | – | Write, Read  | – | – | Write, Read  | Write, Read  | – |

| BITFIELD     | BITS | DESCRIPTION   | DECODE  |
|--------------|------|---|---|
| TX_COMP_EN_B | 5    | Enables jitter minimization compensation  | 0b0: Jitter compensation disabled<br>0b1: Jitter compensation enabled                                       |
| GPIO_RX_EN_B | 2    | GPIO out source control.<br>Set to 1 to receive GPIO value from GMSL link. Set GPIO_OUT_DIS to 0 to output the received value on the local MFP. | 0b0: This GPIO source disabled for GMSL reception<br>0b1: This GPIO source enabled for GMSL reception       |
| GPIO_TX_EN_B | 1    | GPIO Tx source control.<br>Set to 1 to transmit the local MFP input value across the GMSL link.   | 0b0: This GPIO source disabled for GMSL transmission<br>0b1: This GPIO source enabled for GMSL transmission |

### GPIO B (0x52C3)

#### GPIO 6

| BIT         | 7 | 6 | 5 | 4                 | 3 | 2 | 1 | 0 |
|-------------|---|---|---|-------------------|---|---|---|---|
| Field       | – | – | – | GPIO_TX_ID_B[4:0] |   |   |   |   |
| Reset       | – | – | – | 0b00110           |   |   |   |   |
| Access Type | – | – | – | Write, Read       |   |   |   |   |

| BITFIELD     | BITS | DESCRIPTION                        | DECODE                         |
|--------------|------|------------------------------------|--------------------------------|
| GPIO_TX_ID_B | 4:0  | GPIO ID for pin while transmitting | 0bXXXXX: This GPIO transmit ID |

**GPIO C (0x52C4)**

GPIO 6

| BIT         | 7 | 6 | 5 | 4                 | 3 | 2 | 1 | 0 |
|-------------|---|---|---|-------------------|---|---|---|---|
| Field       | – | – | – | GPIO_RX_ID_B[4:0] |   |   |   |   |
| Reset       | – | – | – | 0b00110           |   |   |   |   |
| Access Type | – | – | – | Write, Read       |   |   |   |   |

| BITFIELD     | BITS | DESCRIPTION                     | DECODE                        |
|--------------|------|---------------------------------|-------------------------------|
| GPIO_RX_ID_B | 4:0  | GPIO ID for pin while receiving | 0bXXXXX: This GPIO receive ID |

**GPIO A (0x52C5)**

GPIO 7

| BIT         | 7 | 6 | 5            | 4 | 3 | 2            | 1            | 0 |
|-------------|---|---|--------------|---|---|--------------|--------------|---|
| Field       | – | – | TX_COMP_EN_B | – | – | GPIO_RX_EN_B | GPIO_TX_EN_B | – |
| Reset       | – | – | 0b0          | – | – | 0b0          | 0b0          | – |
| Access Type | – | – | Write, Read  | – | – | Write, Read  | Write, Read  | – |

| BITFIELD     | BITS | DESCRIPTION   | DECODE  |
|--------------|------|---|---|
| TX_COMP_EN_B | 5    | Enables jitter minimization compensation  | 0b0: Jitter compensation disabled<br>0b1: Jitter compensation enabled                                       |
| GPIO_RX_EN_B | 2    | GPIO out source control.<br>Set to 1 to receive GPIO value from GMSL link. Set GPIO_OUT_DIS to 0 to output the received value on the local MFP. | 0b0: This GPIO source disabled for GMSL reception<br>0b1: This GPIO source enabled for GMSL reception       |
| GPIO_TX_EN_B | 1    | GPIO Tx source control.<br>Set to 1 to transmit the local MFP input value across the GMSL link.   | 0b0: This GPIO source disabled for GMSL transmission<br>0b1: This GPIO source enabled for GMSL transmission |

**GPIO B (0x52C6)**

GPIO 7

| BIT         | 7 | 6 | 5 | 4                 | 3 | 2 | 1 | 0 |
|-------------|---|---|---|-------------------|---|---|---|---|
| Field       | – | – | – | GPIO_TX_ID_B[4:0] |   |   |   |   |
| Reset       | – | – | – | 0b00111           |   |   |   |   |
| Access Type | – | – | – | Write, Read       |   |   |   |   |

| BITFIELD     | BITS | DESCRIPTION                        | DECODE                         |
|--------------|------|------------------------------------|--------------------------------|
| GPIO_TX_ID_B | 4:0  | GPIO ID for pin while transmitting | 0bXXXXX: This GPIO transmit ID |

**GPIO C (0x52C7)**

## GPIO 7

| BIT         | 7 | 6 | 5 | 4                 | 3 | 2 | 1 | 0 |
|-------------|---|---|---|-------------------|---|---|---|---|
| Field       | – | – | – | GPIO_RX_ID_B[4:0] |   |   |   |   |
| Reset       | – | – | – | 0b00111           |   |   |   |   |
| Access Type | – | – | – | Write, Read       |   |   |   |   |

| BITFIELD     | BITS | DESCRIPTION                     | DECODE                        |
|--------------|------|---------------------------------|-------------------------------|
| GPIO_RX_ID_B | 4:0  | GPIO ID for pin while receiving | 0bXXXXX: This GPIO receive ID |

**GPIO A (0x52C8)**

## GPIO 8

| BIT         | 7 | 6 | 5            | 4 | 3 | 2            | 1            | 0 |
|-------------|---|---|--------------|---|---|--------------|--------------|---|
| Field       | – | – | TX_COMP_EN_B | – | – | GPIO_RX_EN_B | GPIO_TX_EN_B | – |
| Reset       | – | – | 0b0          | – | – | 0b0          | 0b0          | – |
| Access Type | – | – | Write, Read  | – | – | Write, Read  | Write, Read  | – |

| BITFIELD     | BITS | DESCRIPTION   | DECODE  |
|--------------|------|---|---|
| TX_COMP_EN_B | 5    | Enables jitter minimization compensation  | 0b0: Jitter compensation disabled<br>0b1: Jitter compensation enabled                                       |
| GPIO_RX_EN_B | 2    | GPIO out source control.<br>Set to 1 to receive GPIO value from GMSL link. Set GPIO_OUT_DIS to 0 to output the received value on the local MFP. | 0b0: This GPIO source disabled for GMSL reception<br>0b1: This GPIO source enabled for GMSL reception       |
| GPIO_TX_EN_B | 1    | GPIO Tx source control.<br>Set to 1 to transmit the local MFP input value across the GMSL link.   | 0b0: This GPIO source disabled for GMSL transmission<br>0b1: This GPIO source enabled for GMSL transmission |

**GPIO B (0x52C9)**

## GPIO 8

| BIT   | 7 | 6 | 5 | 4                 | 3 | 2 | 1 | 0 |
|-------|---|---|---|-------------------|---|---|---|---|
| Field | – | – | – | GPIO_TX_ID_B[4:0] |   |   |   |   |

|                    |   |   |   |             |
|--------------------|---|---|---|-------------|
| <b>Reset</b>       | – | – | – | 0b01000     |
| <b>Access Type</b> | – | – | – | Write, Read |

| BITFIELD     | BITS | DESCRIPTION                        | DECODE                         |
|--------------|------|------------------------------------|--------------------------------|
| GPIO_TX_ID_B | 4:0  | GPIO ID for pin while transmitting | 0bXXXXX: This GPIO transmit ID |

**GPIO C (0x52CA)**

## GPIO 8

| BIT                | 7 | 6 | 5 | 4                 | 3 | 2 | 1 | 0 |
|--------------------|---|---|---|-------------------|---|---|---|---|
| <b>Field</b>       | – | – | – | GPIO_RX_ID_B[4:0] |   |   |   |   |
| <b>Reset</b>       | – | – | – | 0b01000           |   |   |   |   |
| <b>Access Type</b> | – | – | – | Write, Read       |   |   |   |   |

| BITFIELD     | BITS | DESCRIPTION                     | DECODE                        |
|--------------|------|---------------------------------|-------------------------------|
| GPIO_RX_ID_B | 4:0  | GPIO ID for pin while receiving | 0bXXXXX: This GPIO receive ID |

**GPIO A (0x52CB)**

## GPIO 9

| BIT                | 7 | 6 | 5            | 4 | 3 | 2            | 1            | 0 |
|--------------------|---|---|--------------|---|---|--------------|--------------|---|
| <b>Field</b>       | – | – | TX_COMP_EN_B | – | – | GPIO_RX_EN_B | GPIO_TX_EN_B | – |
| <b>Reset</b>       | – | – | 0b0          | – | – | 0b0          | 0b0          | – |
| <b>Access Type</b> | – | – | Write, Read  | – | – | Write, Read  | Write, Read  | – |

| BITFIELD     | BITS | DESCRIPTION   | DECODE  |
|--------------|------|---|---|
| TX_COMP_EN_B | 5    | Enables jitter minimization compensation  | 0b0: Jitter compensation disabled<br>0b1: Jitter compensation enabled                                       |
| GPIO_RX_EN_B | 2    | GPIO out source control.<br>Set to 1 to receive GPIO value from GMSL link. Set GPIO_OUT_DIS to 0 to output the received value on the local MFP. | 0b0: This GPIO source disabled for GMSL reception<br>0b1: This GPIO source enabled for GMSL reception       |
| GPIO_TX_EN_B | 1    | GPIO Tx source control.<br>Set to 1 to transmit the local MFP input value across the GMSL link.   | 0b0: This GPIO source disabled for GMSL transmission<br>0b1: This GPIO source enabled for GMSL transmission |

**GPIO B (0x52CC)**

## GPIO 9

| BIT         | 7 | 6 | 5 | 4                 | 3 | 2 | 1 | 0 |
|-------------|---|---|---|-------------------|---|---|---|---|
| Field       | – | – | – | GPIO_TX_ID_B[4:0] |   |   |   |   |
| Reset       | – | – | – | 0b01001           |   |   |   |   |
| Access Type | – | – | – | Write, Read       |   |   |   |   |

| BITFIELD     | BITS | DESCRIPTION                        | DECODE                         |
|--------------|------|------------------------------------|--------------------------------|
| GPIO_TX_ID_B | 4:0  | GPIO ID for pin while transmitting | 0bXXXXX: This GPIO transmit ID |

**GPIO C (0x52CD)**

## GPIO 9

| BIT         | 7 | 6 | 5 | 4                 | 3 | 2 | 1 | 0 |
|-------------|---|---|---|-------------------|---|---|---|---|
| Field       | – | – | – | GPIO_RX_ID_B[4:0] |   |   |   |   |
| Reset       | – | – | – | 0b01001           |   |   |   |   |
| Access Type | – | – | – | Write, Read       |   |   |   |   |

| BITFIELD     | BITS | DESCRIPTION                     | DECODE                        |
|--------------|------|---------------------------------|-------------------------------|
| GPIO_RX_ID_B | 4:0  | GPIO ID for pin while receiving | 0bXXXXX: This GPIO receive ID |

**GPIO A (0x52CE)**

## GPIO 10

| BIT         | 7 | 6 | 5            | 4 | 3 | 2            | 1            | 0 |
|-------------|---|---|--------------|---|---|--------------|--------------|---|
| Field       | – | – | TX_COMP_EN_B | – | – | GPIO_RX_EN_B | GPIO_TX_EN_B | – |
| Reset       | – | – | 0b0          | – | – | 0b0          | 0b0          | – |
| Access Type | – | – | Write, Read  | – | – | Write, Read  | Write, Read  | – |

| BITFIELD     | BITS | DESCRIPTION   | DECODE  |
|--------------|------|---|---|
| TX_COMP_EN_B | 5    | Enables jitter minimization compensation  | 0b0: Jitter compensation disabled<br>0b1: Jitter compensation enabled                                       |
| GPIO_RX_EN_B | 2    | GPIO out source control.<br>Set to 1 to receive GPIO value from GMSL link. Set GPIO_OUT_DIS to 0 to output the received value on the local MFP. | 0b0: This GPIO source disabled for GMSL reception<br>0b1: This GPIO source enabled for GMSL reception       |
| GPIO_TX_EN_B | 1    | GPIO Tx source control.<br>Set to 1 to transmit the local MFP input value across the GMSL link.   | 0b0: This GPIO source disabled for GMSL transmission<br>0b1: This GPIO source enabled for GMSL transmission |

**GPIO B (0x52CF)**

GPIO 10

| BIT         | 7 | 6 | 5 | 4                 | 3 | 2 | 1 | 0 |
|-------------|---|---|---|-------------------|---|---|---|---|
| Field       | – | – | – | GPIO_TX_ID_B[4:0] |   |   |   |   |
| Reset       | – | – | – | 0b01010           |   |   |   |   |
| Access Type | – | – | – | Write, Read       |   |   |   |   |

| BITFIELD     | BITS | DESCRIPTION                        | DECODE                         |
|--------------|------|------------------------------------|--------------------------------|
| GPIO_TX_ID_B | 4:0  | GPIO ID for pin while transmitting | 0bXXXXX: This GPIO transmit ID |

**GPIO C (0x52D0)**

GPIO 10

| BIT         | 7 | 6 | 5 | 4                 | 3 | 2 | 1 | 0 |
|-------------|---|---|---|-------------------|---|---|---|---|
| Field       | – | – | – | GPIO_RX_ID_B[4:0] |   |   |   |   |
| Reset       | – | – | – | 0b01010           |   |   |   |   |
| Access Type | – | – | – | Write, Read       |   |   |   |   |

| BITFIELD     | BITS | DESCRIPTION                     | DECODE                        |
|--------------|------|---------------------------------|-------------------------------|
| GPIO_RX_ID_B | 4:0  | GPIO ID for pin while receiving | 0bXXXXX: This GPIO receive ID |

**GPIO A (0x52D1)**

GPIO 11

| BIT         | 7 | 6 | 5            | 4 | 3 | 2            | 1            | 0 |
|-------------|---|---|--------------|---|---|--------------|--------------|---|
| Field       | – | – | TX_COMP_EN_B | – | – | GPIO_RX_EN_B | GPIO_TX_EN_B | – |
| Reset       | – | – | 0b0          | – | – | 0b0          | 0b0          | – |
| Access Type | – | – | Write, Read  | – | – | Write, Read  | Write, Read  | – |

| BITFIELD     | BITS | DESCRIPTION   | DECODE  |
|--------------|------|---|---|
| TX_COMP_EN_B | 5    | Enables jitter minimization compensation  | 0b0: Jitter compensation disabled<br>0b1: Jitter compensation enabled                                 |
| GPIO_RX_EN_B | 2    | GPIO out source control.<br>Set to 1 to receive GPIO value from GMSL link. Set GPIO_OUT_DIS to 0 to output the received value on the local MFP. | 0b0: This GPIO source disabled for GMSL reception<br>0b1: This GPIO source enabled for GMSL reception |

| BITFIELD     | BITS | DESCRIPTION   | DECODE  |
|--------------|------|---|---|
| GPIO_TX_EN_B | 1    | GPIO Tx source control.<br>Set to 1 to transmit the local MFP input value across the GMSL link. | 0b0: This GPIO source disabled for GMSL transmission<br>0b1: This GPIO source enabled for GMSL transmission |

**GPIO B (0x52D2)**

GPIO 11

| BIT         | 7 | 6 | 5 | 4                 | 3 | 2 | 1 | 0 |
|-------------|---|---|---|-------------------|---|---|---|---|
| Field       | – | – | – | GPIO_TX_ID_B[4:0] |   |   |   |   |
| Reset       | – | – | – | 0b01011           |   |   |   |   |
| Access Type | – | – | – | Write, Read       |   |   |   |   |

| BITFIELD     | BITS | DESCRIPTION                        | DECODE                         |
|--------------|------|------------------------------------|--------------------------------|
| GPIO_TX_ID_B | 4:0  | GPIO ID for pin while transmitting | 0bXXXXX: This GPIO transmit ID |

**GPIO C (0x52D3)**

GPIO 11

| BIT         | 7 | 6 | 5 | 4                 | 3 | 2 | 1 | 0 |
|-------------|---|---|---|-------------------|---|---|---|---|
| Field       | – | – | – | GPIO_RX_ID_B[4:0] |   |   |   |   |
| Reset       | – | – | – | 0b01011           |   |   |   |   |
| Access Type | – | – | – | Write, Read       |   |   |   |   |

| BITFIELD     | BITS | DESCRIPTION                     | DECODE                        |
|--------------|------|---------------------------------|-------------------------------|
| GPIO_RX_ID_B | 4:0  | GPIO ID for pin while receiving | 0bXXXXX: This GPIO receive ID |

**GPIO A (0x52D4)**

GPIO 12

| BIT         | 7 | 6 | 5            | 4 | 3 | 2            | 1            | 0 |
|-------------|---|---|--------------|---|---|--------------|--------------|---|
| Field       | – | – | TX_COMP_EN_B | – | – | GPIO_RX_EN_B | GPIO_TX_EN_B | – |
| Reset       | – | – | 0b0          | – | – | 0b0          | 0b0          | – |
| Access Type | – | – | Write, Read  | – | – | Write, Read  | Write, Read  | – |

| BITFIELD     | BITS | DESCRIPTION   | DECODE  |
|--------------|------|---|---|
| TX_COMP_EN_B | 5    | Enables jitter minimization compensation  | 0b0: Jitter compensation disabled<br>0b1: Jitter compensation enabled                                       |
| GPIO_RX_EN_B | 2    | GPIO out source control.<br>Set to 1 to receive GPIO value from GMSL link. Set GPIO_OUT_DIS to 0 to output the received value on the local MFP. | 0b0: This GPIO source disabled for GMSL reception<br>0b1: This GPIO source enabled for GMSL reception       |
| GPIO_TX_EN_B | 1    | GPIO Tx source control.<br>Set to 1 to transmit the local MFP input value across the GMSL link.   | 0b0: This GPIO source disabled for GMSL transmission<br>0b1: This GPIO source enabled for GMSL transmission |

**GPIO B (0x52D5)**

GPIO 12

| BIT         | 7 | 6 | 5 | 4                 | 3 | 2 | 1 | 0 |
|-------------|---|---|---|-------------------|---|---|---|---|
| Field       | – | – | – | GPIO_TX_ID_B[4:0] |   |   |   |   |
| Reset       | – | – | – | 0b01100           |   |   |   |   |
| Access Type | – | – | – | Write, Read       |   |   |   |   |

| BITFIELD     | BITS | DESCRIPTION                        | DECODE                         |
|--------------|------|------------------------------------|--------------------------------|
| GPIO_TX_ID_B | 4:0  | GPIO ID for pin while transmitting | 0bXXXXX: This GPIO transmit ID |

**GPIO C (0x52D6)**

GPIO 12

| BIT         | 7 | 6 | 5 | 4                 | 3 | 2 | 1 | 0 |
|-------------|---|---|---|-------------------|---|---|---|---|
| Field       | – | – | – | GPIO_RX_ID_B[4:0] |   |   |   |   |
| Reset       | – | – | – | 0b01100           |   |   |   |   |
| Access Type | – | – | – | Write, Read       |   |   |   |   |

| BITFIELD     | BITS | DESCRIPTION                     | DECODE                        |
|--------------|------|---------------------------------|-------------------------------|
| GPIO_RX_ID_B | 4:0  | GPIO ID for pin while receiving | 0bXXXXX: This GPIO receive ID |

## Revision History

| REVISION NUMBER | REVISION DATE | DESCRIPTION  | PAGES CHANGED |
|-----------------|---------------|--|---------------|
| 0               | 8/22          | Initial release for market intro   | —             |
| 1               | 1/24          | <p><i>Global:</i><br/>Master/Slave updated to Main/Subordinate<br/>Main I<sup>2</sup>C updated to Primary I<sup>2</sup>C<br/>Detailed Description<br/>Removed rise time symbol TRLP.<br/>Updated GMSL2 Lock Time section and figure.<br/>Updated t<sub>WAKEUP</sub> typical time and max time which includes BIST.<br/>Tunneling and Pixel Modes section updated, tunneling mode figure updated.</p> <p><i>Register Table:</i><br/>Global updates to descriptions and decodes for clarity and understanding.<br/>Unhid registers PORT_TUN_ONLY, RLMSB, RLMS1F, RLMS3E, RLMS3F, RLMS45, RLMS49, REGCRC8-to-REGCRC23.</p>  | —             |
| 2               | 4/26          | <p>Data Sheet edits related to Errata Sheet: None.</p> <p><i>Global:</i> Removed MIPI trademark information.</p> <p><i>Data Sheet:</i><br/>Package Information: Updated Package Code column with note to click on Land Pattern Number link.<br/>EC table: Updated D-PHY HS Transmitter section, Single-Ended Output Impedance Mismatch row from 15% to 10%.<br/>Updated sections Vertical and Data Enable or Data Valid Sync Outputs, Video Pipes, and Power-Up and Link Start-Up for better understanding.<br/>Removed MIPI trademark information from back page and from Figure 2 to Figure 8 and Figures 11 to Figure 15 with note to contact factory.<br/>Deleted duplicated Ideal Single-Ended and Resulting Differential High-Signals (Figure 19).</p> <p><i>Register Map:</i> Unhid registers MIPI_PRBS_0 (0x350), MIPI_PRBS_1 (0x351), PM_OV_STAT (0x560), RLMSA8 (0x14A8, 0x15A8) RLMSA9 (0x14A9, 0x15A9), RLMS76 (0x1476, 0x1576) Unhid bitfield DIS_REM_CC_2_B in REG6 (0x06).<br/>Updated decodes in PHYC_WBLOCK_DLY bitfield in RLMSA5, registers (0x14A5, 0x15A5), and GPIO_RX_EN and GPIO_TX_EN bitfields in GPIO_A, registers (0x2B0, 0x2B3, 0x2B6, 0x2B9, 2x2BC, 0x2BF, 0x2C2, 0x2C5, 0x2C8, 0x2CB, 0x2CE, 0x2D1, 0x2D4, 0x52B0, 0x52B3, 0x52B6, 0x52B9, 0x52BC, 0x52BF, 0x52C2, 0x52C5, 0x52C8, 0x52CB, 0x52CE, 0x52D1, 0x52D4).</p> | —             |

