

# 54V, 140A DC/DC $\mu$ Module Regulator with PMBus Interface

## FEATURES

- **High Efficiency at High Frequency**
  - Up to 93.8% Efficiency at 813kHz, 54V<sub>IN</sub> to 3.3V<sub>OUT</sub>
- **PMBus-Compliant I<sup>2</sup>C Serial Interface**
  - Monitor Voltage, Current, Temperature and Faults
  - Internal EEPROM Fault Log Record
  - Digitally Programmable Control Loop
  - Program Voltage, Current Limits, Soft-Start/Soft-Stop, Frequency Synchronization and Phasing, Power-Good, Warnings, and Faults
- **Wide Input Voltage Range: 45V to 65V**
- **Output Voltage Range: 0.5V to 3.6V**
- **Optimized for 45V to 65V<sub>IN</sub> to 3.3V<sub>OUT</sub>**
- **±0.5% Maximum DC Output Error with Differential Remote Voltage Sense**
- **±3% Current Readback Accuracy**
- Parallel and Current Share Multiple  $\mu$ Module ICs
- 22mm × 24mm × 22mm Surface-Mounted Package

## APPLICATIONS

- High Current Distributed Power Systems
- Servers, Network, and Storage Equipment
- Intelligent Energy Efficient Power Regulation

## DESCRIPTION

The LTP<sup>®</sup>8802A-1B is a 140A step-down  $\mu$ Module<sup>®</sup> (micromodule) regulator that provides microprocessor core voltage from a 54V power distribution architecture. It features remote configurability and telemetry monitoring of power management parameters over PMBus, an open standard I<sup>2</sup>C-based digital interface protocol.

The LTP8802A-1B is comprised of a programmable digital control system with precision mixed-signal circuitry, EEPROM, power MOSFETs, planar transformer, inductors, and supporting components. Its high level of integration minimizes component count and design time and maximizes flexibility and power density.

The LTP8802A-1B preserves high efficiency at high conversion ratios by utilizing a quasi-resonant architecture that reduces high voltage switching losses.

The LTP8802A-1B is available in a 22mm × 24mm × 22mm surface-mounted open frame package.

All registered trademarks and trademarks are the property of their respective owners.

## TYPICAL APPLICATION

3.3V, 140A Output DC/DC Module Regulator with PMBus Serial Interface

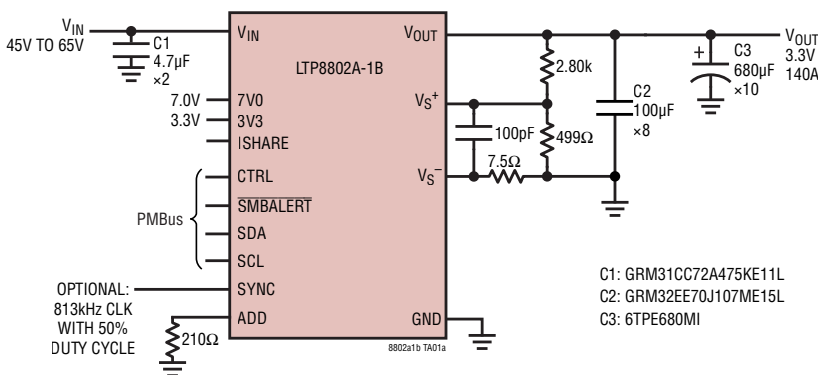

3.3V<sub>OUT</sub> Efficiency and Power Loss

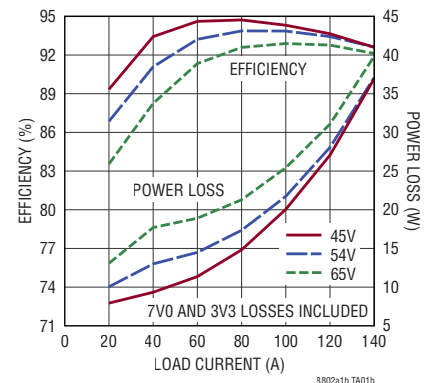

# LTP8802A-1B

## ABSOLUTE MAXIMUM RATINGS

(Note 1)

$V_{IN}$ .....	-0.3V to 70V
7V0 .....	-0.3V to 7.75V
3V3, SYNC, CTRL, $\overline{\text{SMBALERT}}$ , SDA, SCL, ISHARE, ADD, $V_{OUT}$ .....	-0.3V to 3.6V
$V_{S+}$ .....	-0.3V to 1.6V
$V_{S-}$ .....	-0.3V to 0.3V
Operating Junction Temperature Range	
LTP8802A-1B (Note 2, Note 3) .....	0°C to 125°C
Storage Temperature Range (Note 2) .....	-40°C to 150°C
Peak Solder Reflow Body Temperature .....	245°C

## PIN CONFIGURATION

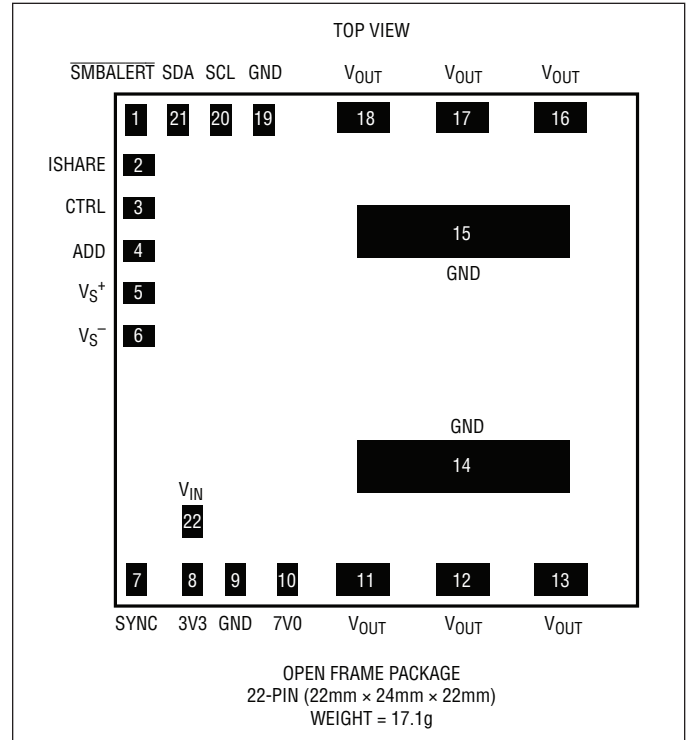

## ORDER INFORMATION

LEAD FREE FINISH	PART MARKING	PACKAGE DESCRIPTION	MSL RATING	TEMPERATURE RANGE
LTP8802A-1BIPV#PBF	LTP8802A-1B	22-Pin (22mm × 24mm) Open Frame	3	0°C to 125°C

Contact the factory for parts specified with wider operating temperature ranges.

## ELECTRICAL CHARACTERISTICS

The ● denotes the specifications which apply over the full operating temperature range, otherwise specifications are at  $T_A = 25^\circ\text{C}$ .

SYMBOL	PARAMETER	CONDITIONS	MIN	TYP	MAX	UNITS	
<b>V<sub>IN</sub> Supply</b>							
V <sub>IN</sub>	Input Operating Range		●	45	65	V	
V <sub>IN(UVLO)</sub>	Input Undervoltage	V <sub>IN</sub> Rising		38	40	42	V
		V <sub>IN</sub> Falling		36	38	40	V
V <sub>IN(OVLO)</sub>	Input Overvoltage	V <sub>IN</sub> Rising		67	70	73	V
		V <sub>IN</sub> Falling		65	68	71	V
I <sub>I(VIN)</sub>	No-Load Input Current, f <sub>SW</sub> = 813kHz	CTRL = 0V		0.1		mA	
	Input Supply Current, f <sub>SW</sub> = 813kHz	I <sub>OUT</sub> = 0A, V <sub>IN</sub> = 54V, V <sub>OUT</sub> = 3.3V		143		mA	
		I <sub>OUT</sub> = 20A, V <sub>IN</sub> = 54V, V <sub>OUT</sub> = 3.3V		1.36		A	
		I <sub>OUT</sub> = 100A, V <sub>IN</sub> = 54V, V <sub>OUT</sub> = 3.3V		6.50		A	
<b>7V0 Supply</b>							
7V0	7V0 Operating Range		●	6.5	7	7.5	V
7V0(UVLO)	7V0 Undervoltage	7V0 Rising	●			4.5	V
		7V0 Falling	●	3.5			V
I <sub>7V0</sub>	7V0 Input Current		●	0.39	0.46	A	
<b>3V3 Supply</b>							
3V3	3V3 Operating Range		●	3.0	3.3	3.6	V
3V3(UVLO)	3V3 Undervoltage	3V3 Rising	●			3.0	V
		3V3 Falling	●	2.75			V
I <sub>3V3</sub>	3V3 Input Current		●	60	70	mA	
<b>Output Specifications</b>							
I <sub>OUT</sub>	Output Current Range		●	0	140	A	
I <sub>OUT(MAX)</sub>	Output Current Limit			180		A	
V <sub>OUT</sub>	Regulated Output Voltage	I <sub>OUT</sub> = 0A, V <sub>IN</sub> = 54V, V <sub>OUT</sub> Set to 3.300V, T <sub>J</sub> = 25°C		3.283	3.300	3.316	V
		I <sub>OUT</sub> = 0A, V <sub>IN</sub> = 54V, V <sub>OUT</sub> Set to 3.300V, T <sub>J</sub> = 0°C to 125°C	●	3.240	3.300	3.352	V
V <sub>OUT(LOAD+LINE)</sub>	Line + Load Regulation	I <sub>OUT</sub> = 0A to 140A, V <sub>IN</sub> = 48V to 65V	●	3.234	3.300	3.366	V
V <sub>OUT(AC)</sub>	V <sub>OUT(PK-PK)</sub>	V <sub>IN</sub> = 54V, V <sub>OUT</sub> = 3.3V, C <sub>OUT</sub> = 800μF MLCC, 6.8mF POSCAP		5.3		mV	
	V <sub>OUT(RMS)</sub>	V <sub>IN</sub> = 54V, V <sub>OUT</sub> = 3.3V, C <sub>OUT</sub> = 800μF MLCC, 6.8mF POSCAP		2.1		mV	
T <sub>START</sub>	Start Time	CTRL High to V <sub>OUT</sub> = 3.3V		3		ms	
T <sub>STOP</sub>	Stop Time	CTRL Low to Output Disable		10		μs	
ΔV <sub>OUT(LS)</sub>	Maximum Output Voltage Excursion for Dynamic Load Step	V <sub>IN</sub> = 54V, V <sub>OUT</sub> = 3.3V, C <sub>OUT</sub> = 800μF MLCC, 6.8mF POSCAP, ΔI <sub>LOAD</sub> = 35A		60		mV	
T <sub>SETTLE</sub>	V <sub>OUT</sub> Settling Time to 1%	V <sub>IN</sub> = 54V, V <sub>OUT</sub> = 3.3V, C <sub>OUT</sub> = 800μF MLCC, 6.8mF POSCAP, ΔI <sub>LOAD</sub> = 35A		30		μs	
Efficiency		V <sub>IN</sub> = 54V, V <sub>OUT</sub> = 3.3V, I <sub>OUT</sub> = 35A		90.1		%	
		V <sub>IN</sub> = 54V, V <sub>OUT</sub> = 3.3V, I <sub>OUT</sub> = 70A		93.5		%	
		V <sub>IN</sub> = 54V, V <sub>OUT</sub> = 3.3V, I <sub>OUT</sub> = 105A		93.8		%	
		V <sub>IN</sub> = 54V, V <sub>OUT</sub> = 3.3V, I <sub>OUT</sub> = 140A		92.6		%	

# LTP8802A-1B

## ELECTRICAL CHARACTERISTICS

The ● denotes the specifications which apply over the full operating temperature range, otherwise specifications are at  $T_A = 25^\circ\text{C}$ .

SYMBOL	PARAMETER	CONDITIONS		MIN	TYP	MAX	UNITS
<b>Oscillator</b>							
$f_{\text{SW}}$	Switching Frequency	Switching Frequency set to 813kHz	●	788	813	838	kHz
$f_{\text{SYNC}}$	SYNC Range		●	732	813	894	kHz
<b>PMBus Monitoring</b>							
$I_{\text{MON(OUT)}}$	Output Current Monitor	$70\text{A} \leq I_{\text{OUT}} \leq 140\text{A}$		-5		5	%
		$70\text{A} \leq I_{\text{OUT}} \leq 140\text{A}$	●		±5		%
		$0\text{A} \leq I_{\text{OUT}} \leq 70\text{A}$		-3.6		3.6	A
		$0\text{A} \leq I_{\text{OUT}} \leq 70\text{A}$	●		±4		A
$I_{\text{MON(IN)}}$	Input Current Monitor	$V_{\text{IN}} = 54\text{V}$ , $V_{\text{OUT}} = 3.3\text{V}$ , $I_{\text{OUT}} = 140\text{A}$	●		±5		%
$V_{\text{OUTMON}}$	Output Voltage Monitor	$V_{\text{IN}} = 54\text{V}$ , $V_{\text{OUT}} = 3.3\text{V}$ , $I_{\text{OUT}} = 0\text{A}$ , $T_J = 25^\circ\text{C}$			±0.5		%
		$V_{\text{IN}} = 54\text{V}$ , $V_{\text{OUT}} = 3.3\text{V}$ , $I_{\text{OUT}} = 0\text{A}$ , $T_J = 0^\circ\text{C}$ to $125^\circ\text{C}$	●	-1.5		+1.5	%
$V_{\text{INMON}}$	Input Voltage Monitor	$V_{\text{IN}} = 45\text{V}$ to $65\text{V}$ , $V_{\text{OUT}} = 3.3\text{V}$ , $I_{\text{OUT}} = 70\text{A}$	●		±2		%
$T_{\text{MON}}$	Temp Monitor	$V_{\text{IN}} = 54\text{V}$ , $V_{\text{OUT}} = 3.3\text{V}$ , $I_{\text{OUT}} = 70\text{A}$	●		±10		$^\circ\text{C}$
<b>Leakage Current Digital Inputs (CTRL, SDA, SCL, SYNC)</b>							
$I_{\text{DGL}}$	Input Leakage Current	$0\text{V} \leq V_{\text{PIN}} \leq 3.6\text{V}$	●			10	$\mu\text{A}$
<b>Control Section</b>							
$V_{\text{SCM}}$	VS Common Mode Range		●	-100		+100	mV
$V_{\text{MRGN}}$	Output Voltage Margin Range			0.5		3.60	V
$V_{\text{OUT(OVLO)}}$	Output Overvoltage Protection				4.0		V
<b>Digital Inputs (CTRL, SDA, SCL, SYNC)</b>							
$V_{\text{IH}}$	Input High Threshold Voltage	$V_{3\text{V}3} = 3.3\text{V}$	●	2.1			V
$V_{\text{IL}}$	Input Low Threshold Voltage	$V_{3\text{V}3} = 3.3\text{V}$	●			0.8	V
<b>Digital Outputs (SDA, SMBALERT)</b>							
$V_{\text{OL}}$	Output Low Voltage		●			0.6	V
<b>PMBus Timing Characteristics (SDA, SCL)</b>							
$f_{\text{SCL}}$	Serial Bus Frequency		●	10		400	kHz

**Note 1:** Stresses beyond those listed under Absolute Maximum Ratings may cause permanent damage to the device. Exposure to any Absolute Maximum Rating condition for extended periods may affect device reliability and lifetime.

**Note 2:** The LTP8802A-1BI is guaranteed over the full  $0^\circ\text{C}$  to  $125^\circ\text{C}$  operating junction temperature range. Operating lifetime is derated at junction temperatures greater than  $125^\circ\text{C}$ .

**Note 3:** The LTP8802A-1BI includes overtemperature protection that is intended to protect the device during thermal overload conditions. Internal junction temperature may exceed  $150^\circ\text{C}$  if the overtemperature circuitry is active.

# TYPICAL PERFORMANCE CHARACTERISTICS

**Load Transient Response  
105A to 140A Load Step  
35A/μs 45V<sub>IN</sub> to 3.3V<sub>OUT</sub>**

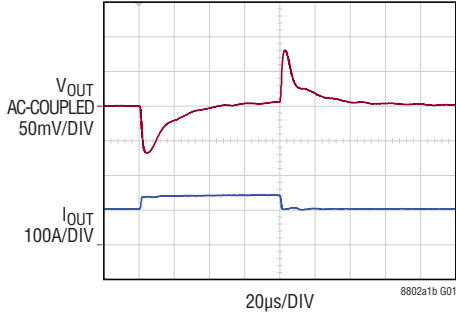

FIGURE 10 CIRCUIT  
V<sub>IN</sub> = 45V, V<sub>OUT</sub> = 3.3V, f<sub>sw</sub> = 813kHz  
C<sub>OUT</sub> = 680μF × 10 POSCAP + 100μF × 8 CERAMIC  
REG FE01h = 20, REG FE02h = 226,  
REG FE03h = 180, REG FE04h = 70

**Load Transient Response  
105A to 140A Load Step  
35A/μs 54V<sub>IN</sub> to 3.3V<sub>OUT</sub>**

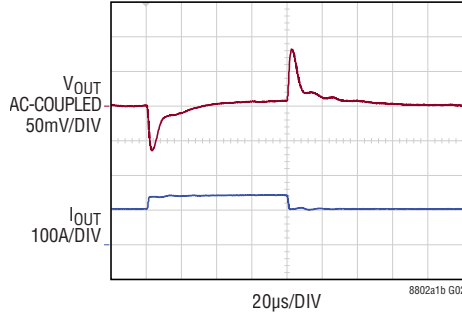

FIGURE 10 CIRCUIT  
V<sub>IN</sub> = 54V, V<sub>OUT</sub> = 3.3V, f<sub>sw</sub> = 813kHz  
C<sub>OUT</sub> = 680μF × 10 POSCAP + 100μF × 8 CERAMIC  
REG FE01h = 20, REG FE02h = 226,  
REG FE03h = 180, REG FE04h = 70

**Load Transient Response  
105A to 140A Load Step  
35A/μs 65V<sub>IN</sub> to 3.3V<sub>OUT</sub>**

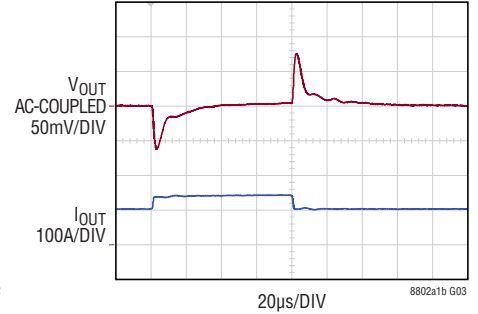
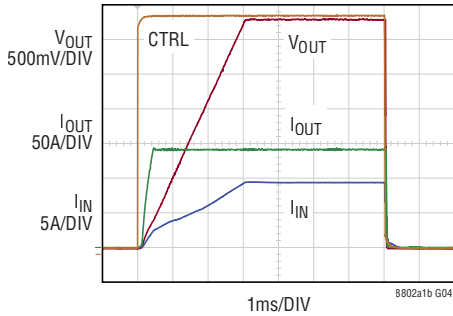
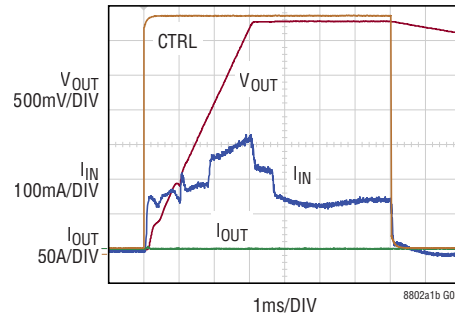

FIGURE 10 CIRCUIT  
V<sub>IN</sub> = 65V, V<sub>OUT</sub> = 3.3V, f<sub>sw</sub> = 813kHz  
C<sub>OUT</sub> = 680μF × 10 POSCAP + 100μF × 8 CERAMIC  
REG FE01h = 20, REG FE02h = 226,  
REG FE03h = 180, REG FE04h = 70

**Full Load Start-Up and Shut-Down  
Triggered by CTRL**



**No Load Start-Up and Shut-Down  
Triggered by CTRL**



**45V<sub>IN</sub> No Load V<sub>OUT</sub> Ripple**

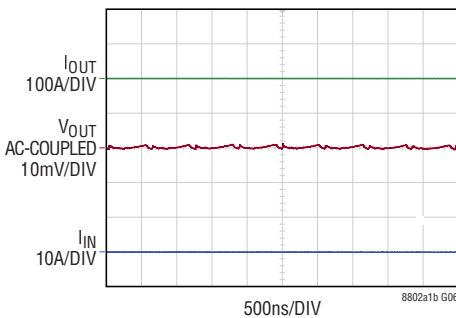

FIGURE 10 CIRCUIT  
V<sub>IN</sub> = 45V, V<sub>OUT</sub> = 3.3V, f<sub>sw</sub> = 813kHz  
NO LOAD ON V<sub>OUT</sub>

**54V<sub>IN</sub> No Load V<sub>OUT</sub> Ripple**

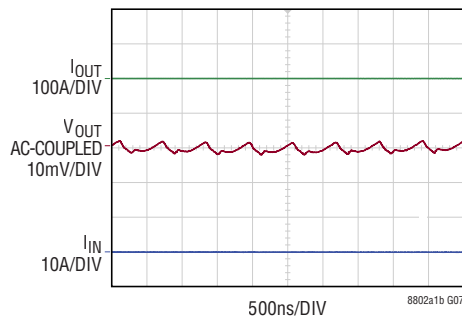

FIGURE 10 CIRCUIT  
V<sub>IN</sub> = 54V, V<sub>OUT</sub> = 3.3V, f<sub>sw</sub> = 813kHz  
NO LOAD ON V<sub>OUT</sub>

**65V<sub>IN</sub> No Load V<sub>OUT</sub> Ripple**

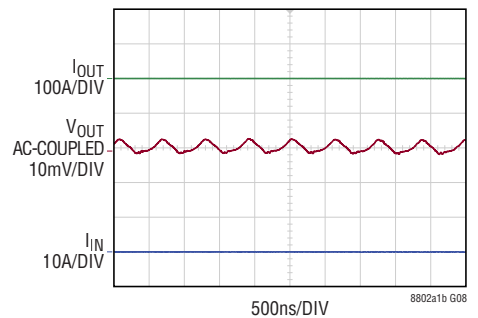

FIGURE 10 CIRCUIT  
V<sub>IN</sub> = 65V, V<sub>OUT</sub> = 3.3V, f<sub>sw</sub> = 813kHz  
NO LOAD ON V<sub>OUT</sub>

## TYPICAL PERFORMANCE CHARACTERISTICS

### 45V<sub>IN</sub> Full Load V<sub>OUT</sub> Ripple

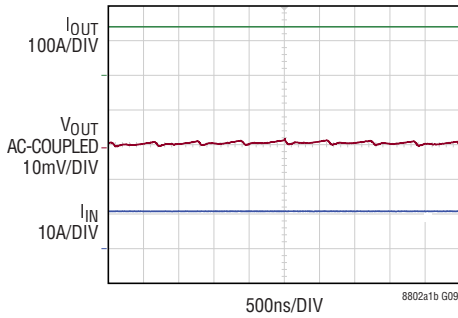

FIGURE 10 CIRCUIT  
 $V_{IN} = 45V$ ,  $V_{OUT} = 3.3V$ ,  $f_{SW} = 813kHz$   
 140A LOAD ON  $V_{OUT}$

### 54V<sub>IN</sub> Full Load V<sub>OUT</sub> Ripple

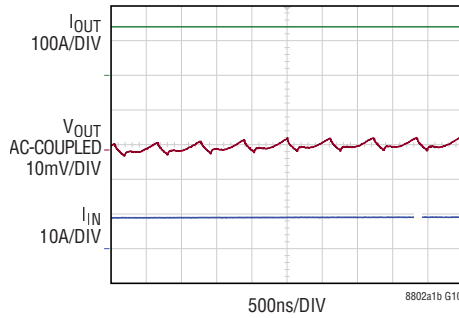

FIGURE 10 CIRCUIT  
 $V_{IN} = 54V$ ,  $V_{OUT} = 3.3V$ ,  $f_{SW} = 813kHz$   
 140A LOAD ON  $V_{OUT}$

### 65V<sub>IN</sub> Full Load V<sub>OUT</sub> Ripple

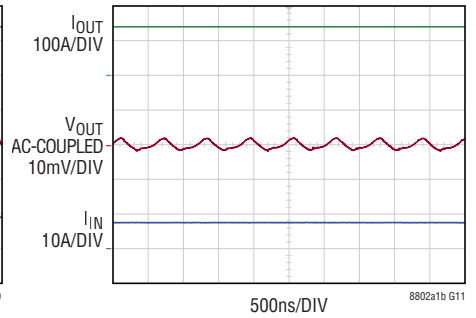
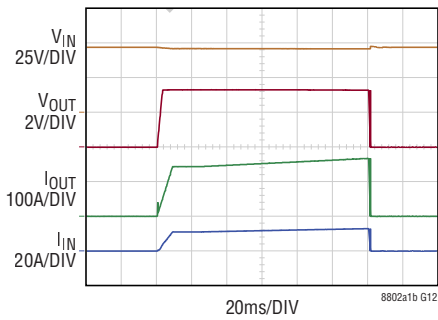
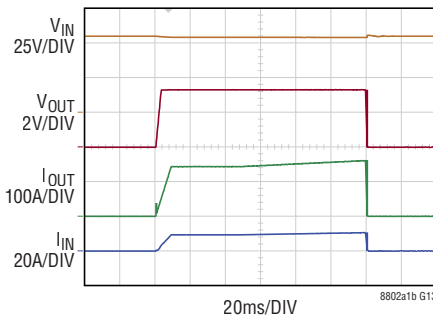

FIGURE 10 CIRCUIT  
 $V_{IN} = 65V$ ,  $V_{OUT} = 3.3V$ ,  $f_{SW} = 813kHz$   
 140A LOAD ON  $V_{OUT}$

### 45V<sub>IN</sub> Overcurrent Protection



### 54V<sub>IN</sub> Overcurrent Protection



### 60V<sub>IN</sub> Overcurrent Protection

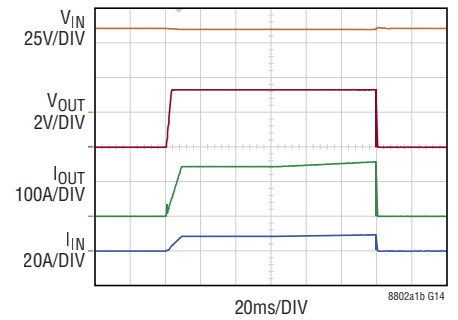

### 45V<sub>IN</sub> Short-Circuit Start-Up

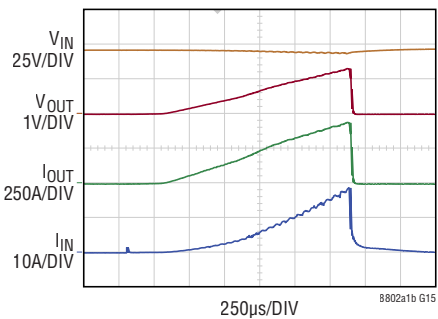

### 54V<sub>IN</sub> Short-Circuit Start-Up

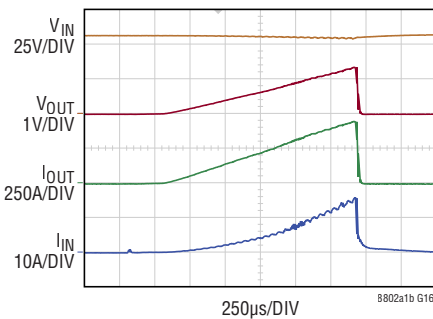

### 60V<sub>IN</sub> Short-Circuit Start-Up

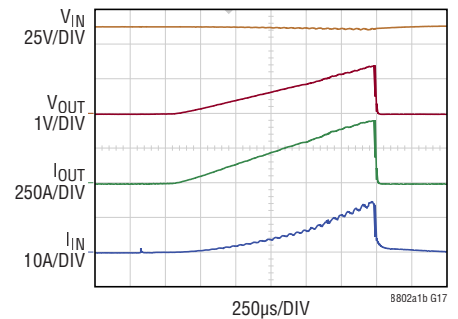

## PIN FUNCTIONS

**SMBALERT (Pin 1):** Power-Good Output (Open-Drain). This pin is also used as the PMBus SMBALERT# signal. If unused, connect to GND.

**ISHARE (Pin 2):** Analog Current Sharing Input and Output. This pin must connect to other  $\mu$ Module IC's ISHARE pins for current sharing. If not used, this pin should be left floating. Do not load ISHARE with external circuitry.

**CTRL (Pin 3):** Power Supply ON/OFF Input. This pin performs hardware on/off control. The factory default setting is to enable the LTP8802A-1B only when CTRL is logic-high (active-high), but can optionally be changed to active-low, or ignored, using register 0x02.

If this pin is not used, connect to 3V3 if it is configured active-high, or GND if it is configured active-low or ignored.

**ADD (Pin 4):** I<sup>2</sup>C/PMBus Address Select Input. Connect a resistor from ADD to GND. See the Applications Information section for more information about the PMBus address selection.

**V<sub>S</sub><sup>+</sup> (Pin 5):** Non-Inverting Voltage Sense Input. This pin functions as the Kelvin sense of V<sub>OUT</sub> at the load as well as the feedback point for the converter control loop. The V<sub>S</sub><sup>+</sup> pin should be tied to a precision feedback resistor divider connected to the output voltage. The V<sub>S</sub><sup>+</sup> pin requires 100pF capacitance to the V<sub>S</sub><sup>-</sup> pin placed close to the LTP8802A-1B. The V<sub>S</sub><sup>+</sup> feedback resistors need to have an equivalent parallel resistance < 2k. Otherwise, the control loop may be adversely affected.

**V<sub>S</sub><sup>-</sup> (Pin 6):** Inverting Voltage Sense Input. This pin functions as the Kelvin sense of GND at the load as well as the GND connection for the feedback point for the converter control loop.

**SYNC (Pin 7):** Synchronization Input Signal. This pin is used as a reference for the internal oscillator and is referenced to GND. The synchronization is disabled by default. Synchronization is configured through register 0xFE55. After changes are made to 0xFE55, the user must then set 0xFE00[6] = 1 for the change to take effect. To enable synchronization, set 0xFE55[6] = 0 and then set 0xFE00[6] = 1 for the value to take effect. For phase interleaving, an optional phase delay in steps of 22.5 degrees can be added using register 0x37[3:0].

If the SYNC pin is not used, it should be either directly connected to GND or connected through a resistor ( $\leq 10k\Omega$ ). In either case, set bit 0xFE55[6] = 1, then set 0xFE00[6] = 1 for the value to take effect. When using a resistor, whether the SYNC function is enabled or not, ensure that the SYNC pin signal consistently meets its specifications in the Electrical Characteristics table.

**3V3 (Pin 8):** The 3V3 pin powers internal  $\mu$ Module circuitry. The typical 3V3 supply current when operating is 60mA. The voltage on this pin must be within the specified operating range before the LTP8802A-1B can be enabled.

**GND (Pins 9, 14, 15, 19):**  $\mu$ Module Ground. The GND pins carry high current and must be connected to large planes with sufficient internal layers. Be sure to keep the voltage at the pins roughly equal by taking care of the direction of current flow and debiasing of the ground planes.

**7V0 (Pin 10):** The 7V0 pin powers internal  $\mu$ Module circuitry, including gate drivers. The typical 7V0 supply current when operating is 0.39A. The voltage on this pin must be within the specified operating range before the LTP8802A-1B can be enabled.

**V<sub>OUT</sub> (Pins 11, 12, 13, 16, 17, 18):** The V<sub>OUT</sub> pins carry the high output current of the converter. As such, these pins must be connected to large power planes with sufficient internal layers. The PCB layout must be such that the two sets of V<sub>OUT</sub> pins see roughly the same voltage. This ensures high efficiency and balanced currents. Output voltage is digitally programmable from 0.5V to 3.6V. The V<sub>OUT</sub> pins are two rows of terminals and carry high steady-state output currents (from 0A up to 140A) and transient currents up to 180A.

**SCL (Pin 20):** I<sup>2</sup>C/PMBus Serial Clock Input and Output (Open-Drain).

**SDA (Pin 21):** I<sup>2</sup>C/PMBus Serial Data Input and Output (Open-Drain).

**V<sub>IN</sub> (Pin 22):** The V<sub>IN</sub> pin supplies current to the primary power switches and operates from 54V/48V nominal inputs; for further details, see Absolute Maximum Ratings and Electrical Characteristics table for input voltage range. The LTP8802-1B requires, at minimum, a total of 10 $\mu$ F from low ESR ceramic bypass capacitors, located as close as possible to the V<sub>IN</sub> and GND pins. Two 4.7 $\mu$ F 1206/1210 X7\* capacitors are recommended.

## APPLICATIONS INFORMATION

### COMPENSATION

The LTP8802A-1B offers programmable loop compensation to optimize the transient response without any hardware change. A Type 3 filter architecture has been implemented. To tailor the loop response to the specific application, the low frequency gain, zero location, pole location and high frequency gain can all be set individually. From the sensed voltage to the duty cycle, the transfer function of the filter in z-domain is resolved by Equation 1.

$$H(z) = \left( \frac{D}{LFG} \cdot \frac{1}{(1-z^{-1})} + \frac{C}{HFG} \left( \frac{1 - \frac{B}{256}z^{-1}}{1 - \frac{A}{256}z^{-1}} \right) \right) \quad (1)$$

Where:

- A = filter pole register value (in decimal), 0xFE03.
- B = filter zero register value (in decimal), 0xFE02.
- C = high frequency gain register value (in decimal), 0xFE04.
- D = low frequency gain register value (in decimal), 0xFE01.
- LFG =  $4.7744 \times 10^7 / f_{SW}$ .
- HFG =  $2.984 \times 10^6 / f_{SW}$ .

As shown in Figure 1, adjusting low frequency gain register value changes the gain of the compensation over the low frequency range without moving the pole and zero locations. Adjusting high frequency gain register value changes the gain of the compensation over the high frequency range without moving the pole and zero locations. As shown in Figure 2, adjusting the pole and zero register values moves the double poles and double zeroes of the compensation. Increasing the filter zero and pole register values separates the double zeroes and double poles. It is recommended that **LTpowerPlay®** be used to program the filter.

It is recommended that the user determines the appropriate value for the compensation registers using the **LTpowerCAD®** tool. An example of the bode plot of the typical application circuit with the recommended compensation settings is shown in Figure 3. Measured

bode plot of the LTP8802A-1B in circuit Figure 9 with register setting (in decimal): 0xFE02 = 226, 0xFE03 = 180, 0xFE04 = 70, 0xFE01 = 8; crossover frequency: 22.0kHz, phase margin 101.7deg, gain margin 14.7dB.

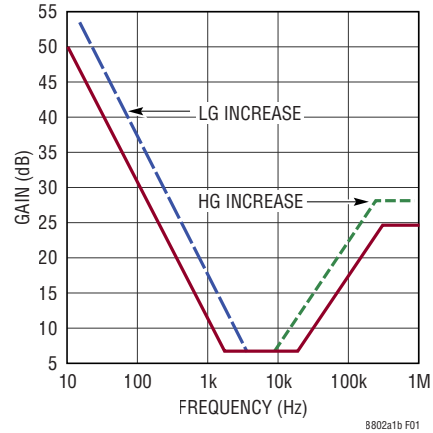

Figure 1. Compensation Gain Adjustment

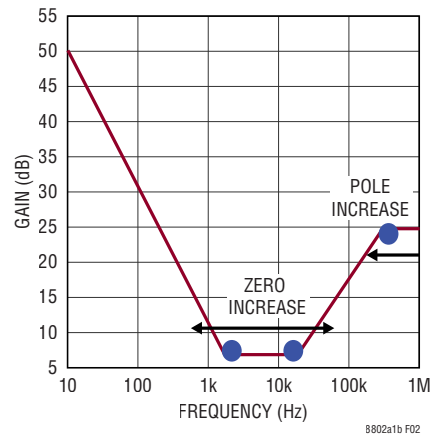

Figure 2. Compensation Poles and Zeroes Adjustment

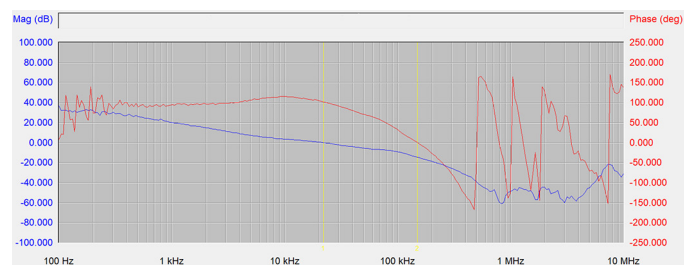

Figure 3. Measured Bode Plot of the LTP8802A-1B



## APPLICATIONS INFORMATION

### PolyPhase CONFIGURATION

When configuring a PolyPhase® rail with multiple LTP8802A-1B, share the SYNC and ISHARE pins, and provide an external clock source. The digital phase-locked loop is capable of determining the frequency on the SYNC pin and locking it to the internal oscillator. The lock or capture range is  $\pm 10\%$  of the switching frequency (813kHz). The relative phasing can be configured in steps of 22.5 degrees, using register 0x37[3:0].

### PolyPhase LOAD SHARING

Multiple LTP8802A-1B can be arrayed in order to provide a balanced load-share solution by connecting the ISHARE pins. Figure 4 illustrates a 2-phase design sharing connections required for load sharing.

### PMBus COMMANDS AND LTpowerPlay

#### PMBus Commands

There are multiple PMBus commands and manufacturer-specific commands, which can be customized to adjust the settings of LTP8802A-1B module, as listed in Table 1. These commands comply to the PMBus Power System Management Protocol. See the PMBus Communication and Command Processing section for details.

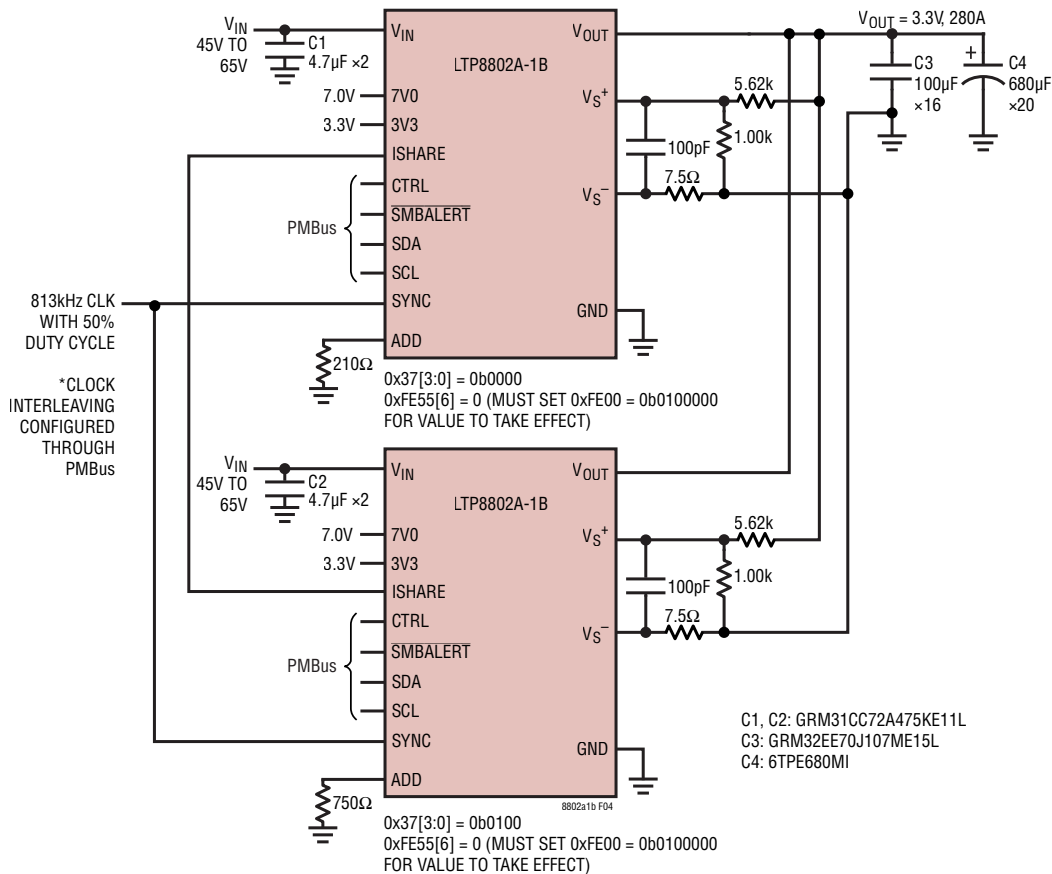

Figure 4. 2-Phase Operation Producing 3.3V at 280A

## APPLICATIONS INFORMATION

**Table 1. LTP8802A-1B Summary of Customizable Commands and Features**

PMBus COMMAND NAME OR FEATURE	CMD CODE REGISTER	COMMAND OR FEATURE DESCRIPTION	TYPE	DATA UNITS	DATA FORMAT	NVM ATTRIBUTES
WRITE_PROTECT	0x10	Protect the PMBus device against accidental writes.	R/W Byte	NA	Bit Field	Stored in user-editable NVM.
VIN_ON	0x35	Sets the value of the input voltage ( $V_{RMS}$ ) at which the device starts power conversion.	R/W Word	Volts	Linear 11	Stored in user-editable NVM.
VIN_OFF	0x36	Sets the value of the input voltage ( $V_{RMS}$ ) at which the device stops power conversion.	R/W word	Volts	Linear 11	Stored in user-editable NVM.
VIN_OV_FAULT_LIMIT	0x55	Sets the upper voltage threshold (in volts) measured at the sense/input pin that causes an overvoltage fault condition.	R/W Word	Volts	Linear 11	Stored in user-editable NVM.
VIN_UV_FAULT_LIMIT	0x59	Sets the lower voltage threshold (in volts) measured at the sense/input pin that causes an undervoltage fault condition.	R/W Word	Volts	Linear 11	Stored in user-editable NVM.
IIN_OC_FAULT_LIMIT	0x5B	Sets the threshold value (in amperes) measured at the sense/input pin that causes an overcurrent fault condition.	R/W Word	Amps	Linear 11	Stored in user-editable NVM.
POUT_OP_FAULT_LIMIT	0x68	Sets the upper power threshold (in watts) measured at the sense/output pin that causes an output overpower fault condition.	R/W Word	Watts	Linear 11	Stored in user-editable NVM.
NM_DIGFILT_LF_GAIN_SETTING	0xFE01	Determines the low frequency gain of the loop response in normal mode.	R/W Byte	NA	NA	Stored in user-editable NVM.
NM_DIGFILT_ZERO_SETTING	0xFE02	Determines the position of the final zero in normal mode.	R/W Byte	NA	NA	Stored in user-editable NVM.
NM_DIGFILT_POLE_SETTING	0xFE03	Determines the position of the final pole in normal mode.	R/W Byte	NA	NA	Stored in user-editable NVM.
NM_DIGFILT_HF_GAIN_SETTING	0xFE04	Determines the high frequency gain of the loop response in normal mode.	R/W Byte	NA	NA	Stored in user-editable NVM.

## APPLICATIONS INFORMATION

### LTpowerPlay: AN INTERACTIVE GUI FOR DIGITAL POWER MODULES

The LTpowerPlay is a powerful graphical user interface (GUI) that supports the digital power module LTP8802A-1B, as shown in Figure 5. In online mode, LTpowerPlay can be used to evaluate single or multiple LTP8802A-1B power modules of different types by connecting to a demo board or the user application. In offline mode with no hardware connected via PMBus, LTpowerPlay can also be used to build the project file with configuration of multiple modules, and the project file can

be saved and reloaded later. Moreover, during board bring-up, LTpowerPlay can be used as a valuable diagnostic tool to program the power system, to tweak the system settings, or to diagnose system issues.

The LTpowerPlay utilizes Analog Device's USB-to-I<sup>2</sup>C/SMBus/PMBus Controller, [DC1613A](#), to communicate with circuit boards including the [DC3190B-F](#) (single LTP8802A-1B module) demo board or a customer target system. Further context information, including tutorial demos, is available [here](#).

The screenshot displays the LTpowerPlay software interface. The main window shows the configuration for a power module (U0 (7h40) -LTP8800\_1). The 'Voltage' tab is selected, showing various configuration parameters. The 'VOUT\_COMMAND' register is highlighted in blue. On the right, the 'Reg Info' window is open, showing the description of the VOUT\_COMMAND register, its register info (Command Code: 0x21, Data Type: Unsigned Linear 16, Scope: Paged), value analysis (GUI Value (hex): 0x3000, GUI Value (meaning): 0.75V), and example code for writing and reading the register.

Figure 5. LTpowerPlay Main Interface

## APPLICATIONS INFORMATION

### PMBus COMMUNICATION AND COMMAND PROCESSING

The LTP8802A-1B series communicate through PMBus with other compliant devices. The LTP8802A-1B is always configured as a subordinate device in the overall system, requiring a two-wire interface with one data pin (SDA) and one clock pin (SCL). As subordinate devices, LTP8802A-1B power modules decode the command sent from the main device and respond accordingly. Data transfer of the PMBus subordinate is based on PMBus commands. According to the PMBus/SMBus/I<sup>2</sup>C communication protocol, all PMBus commands start with a subordinate address with the R/W bit cleared (set to 0), followed by the command code, with mostly the stop bit as the last bit in a complete data transfer.

Commands can be categorized as send, read, or write types. For read or write commands, data is transferred between devices in a byte wide format. For send commands, the subordinate device execute the commands upon receiving the stop bit. To ensure robust communication, the main and subordinate devices send acknowledge (ACK) or no acknowledge (NACK) bits as a method of handshaking, eliminating the busy errors between devices.

Manufacturer-specific extended commands are also supported by LTP8802A-1B. These commands follow the same protocol as the standard PMBus commands. However, the command code consists of two bytes: Command code extension (0xFE) and Extended command

code (0x00 to 0xFF). By use of the manufacturer-specific extended commands, the PMBus command set is greatly extended.

### PMBus ADDRESS SELECTION

The PMBus address is set by connecting an external resistor from the ADD pin to GND. Table 2 lists the recommended resistor values and associated PMBus addresses.

**Table 2. Recommended Resistor Values and Associated PMBus Addresses**

PMBus ADDRESS	1% RESISTOR ON ADD PIN ( $\Omega$ )
0x40	210 (or Connect to GND)
0x41	750
0x42	1330
0x43	2050
0x44	2670
0x45	3570
0x46	4420
0x47	5360
0x48	6340
0x49	7320
0x4A	8450
0x4B	9530
0x4C	10,700
0x4D	12,100
0x4E	13,700
0x4F	15,000 (or Connect to 3V3)

# APPLICATIONS INFORMATION

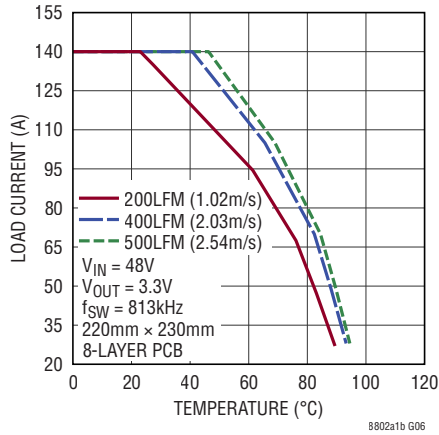

**Figure 6. Thermal Derating**  
 $48V_{IN}$ ,  $3.3V_{OUT}$ ,  $813kHz$

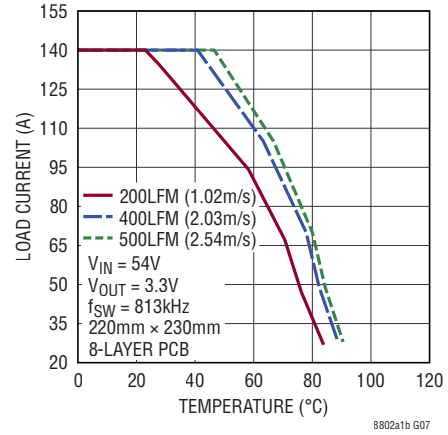

**Figure 7. Thermal Derating**  
 $54V_{IN}$ ,  $3.3V_{OUT}$ ,  $813kHz$

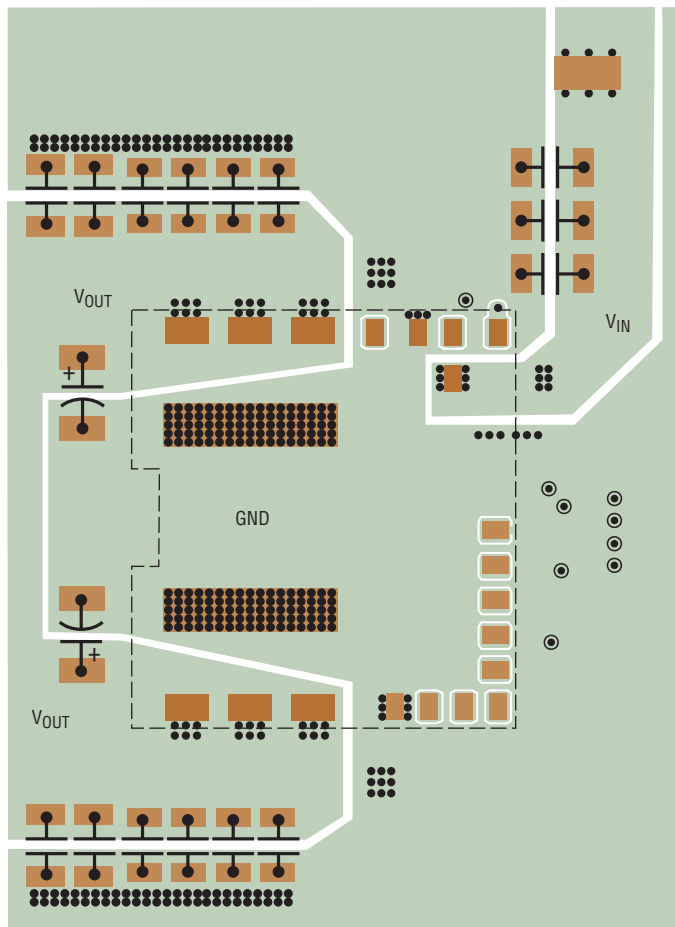

(a) Top Layer

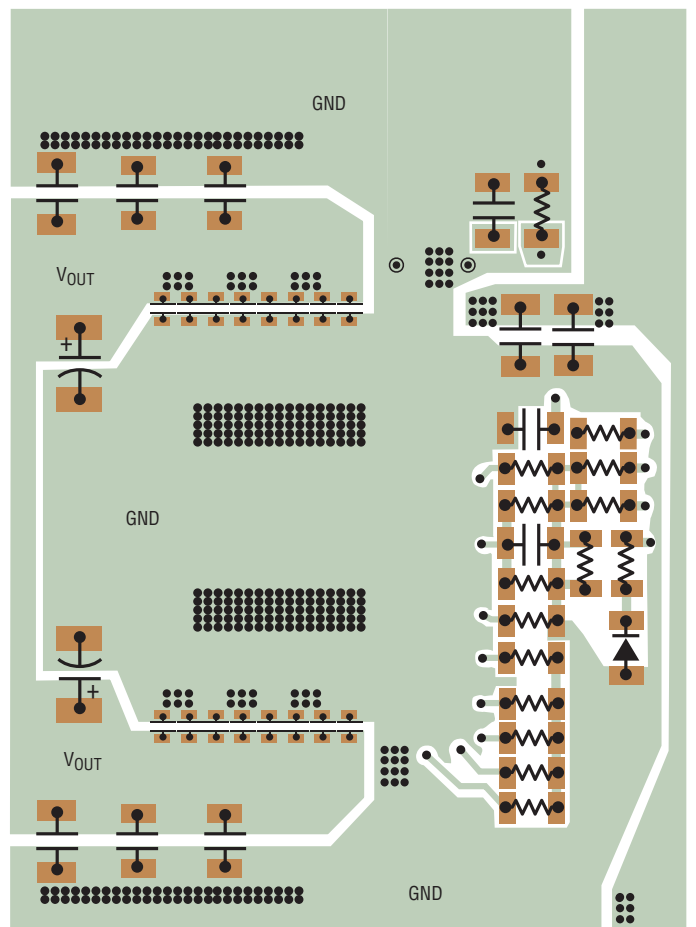

(a) Bottom Layer

**Figure 8. Recommended PCB Layout, Top View**





## TYPICAL APPLICATION

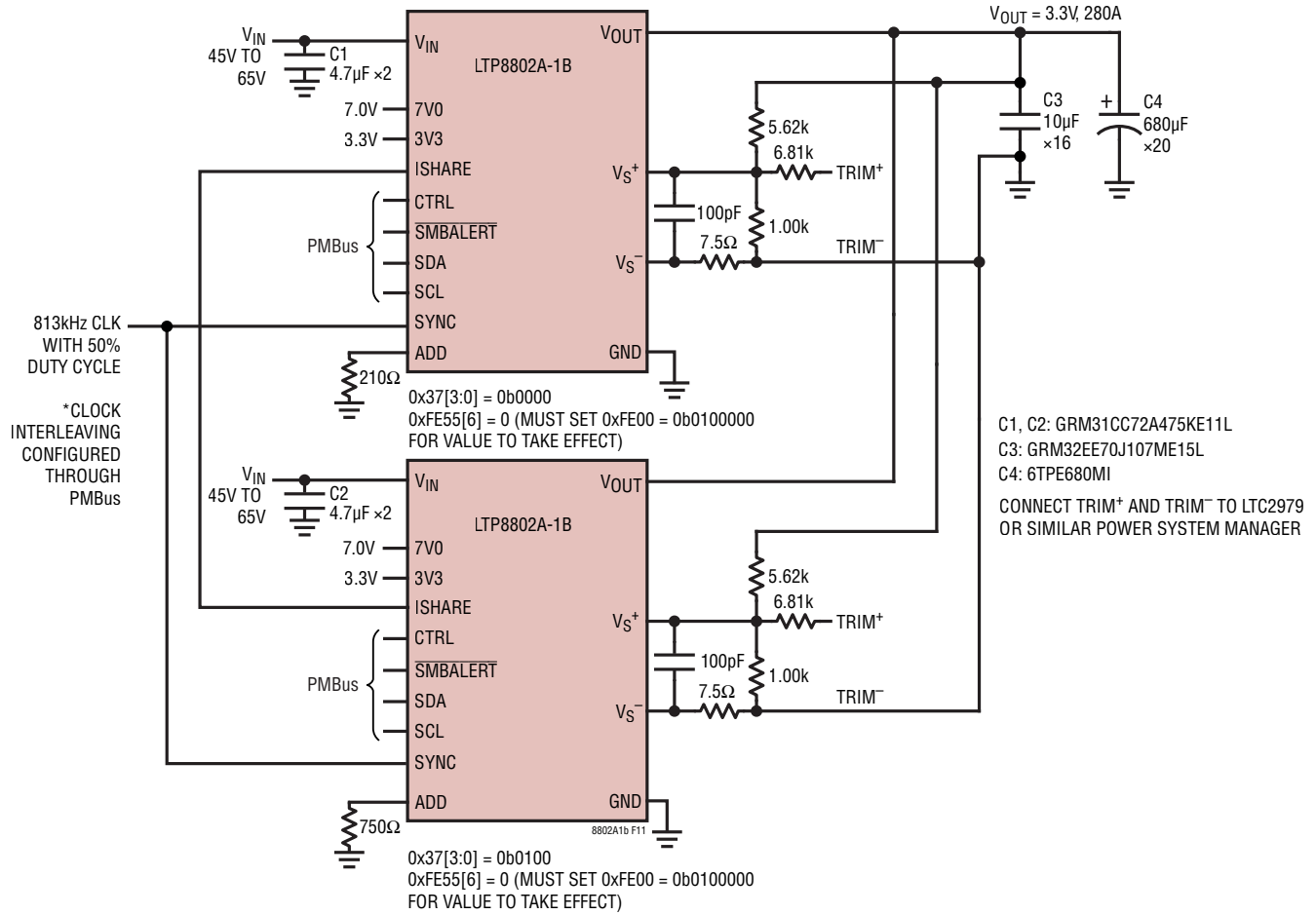
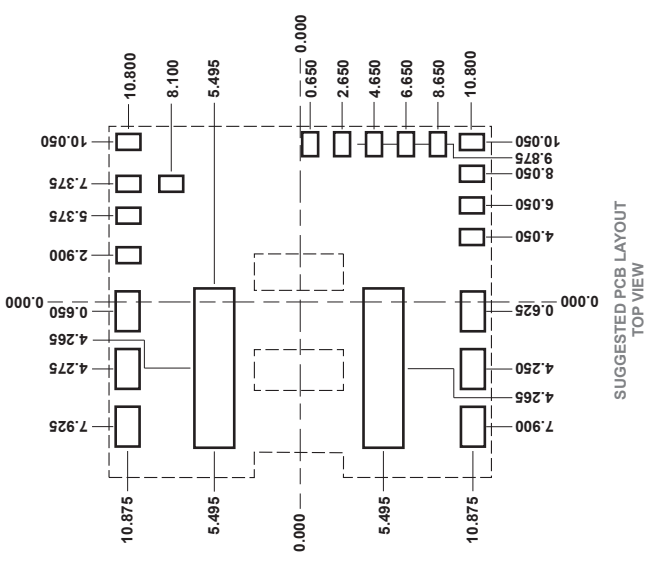
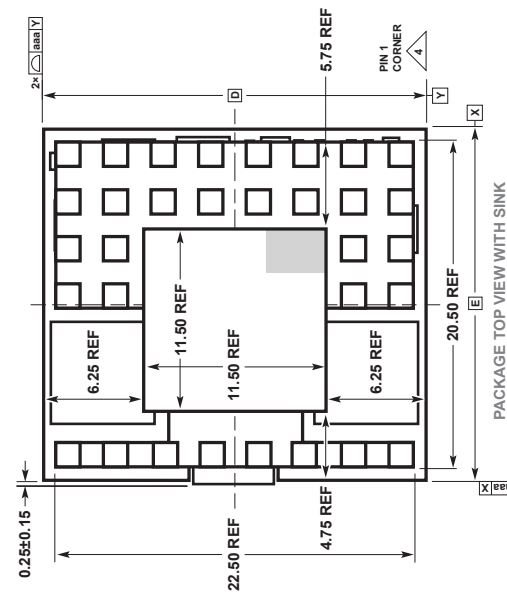
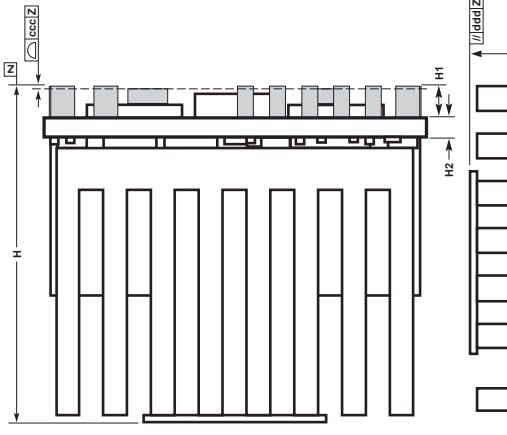
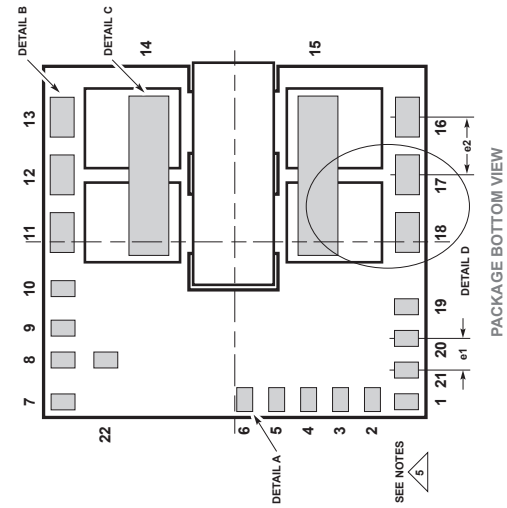

Figure 11. 2-Phase Operation Producing 3.3V at 280A with Power System Management Features



# PACKAGE DESCRIPTION

## 22-Terminal Printed Circuit Assembly [PCA] 22mm x 24mm x 22mm (PC-22-1)



- NOTES:
1. DIMENSIONING AND TOLERANCING PER ASME Y14.5M-1994
  2. ALL DIMENSIONS ARE IN MILLIMETERS
  3. PRIMARY DATUM - Z - IS SEATING PLANE
  4. DETAILS OF PIN 1 IDENTIFIER ARE OPTIONAL BUT MUST BE LOCATED WITHIN THE ZONE INDICATED. THE PIN 1 IDENTIFIER MAY BE EITHER A MOLD OR MARKED FEATURE
  5. PACKAGE PIN LABELING MAY VARY AMONG PRODUCTS. REVIEW EACH PACKAGE LAYOUT CAREFULLY

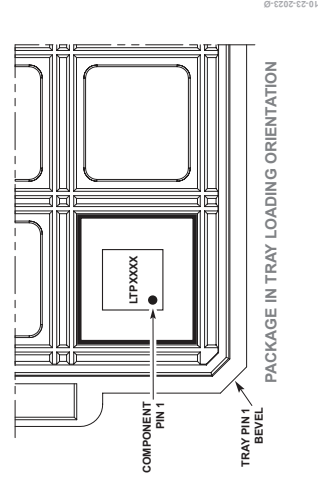

DIMENSIONS				
SYMBOL	MIN	NOM	MAX	NOTES
D		24.00		
E		22.00		
H	21.50	22.00	22.50	
H1	1.70	1.90	2.10	
H2	1.73	1.88	2.03	PCB THK
e1		2.00		
e2		3.65		
aaa			0.20	
bbb			0.40	
ccc			0.20	
ddd			0.35	
TOTAL NUMBER OF INTERCONNECTS: 22				

**PACKAGE DESCRIPTION**

22-Terminal Printed Circuit Assembly [PCA]  
 22mm × 24mm × 22mm  
 (PC-22-1)

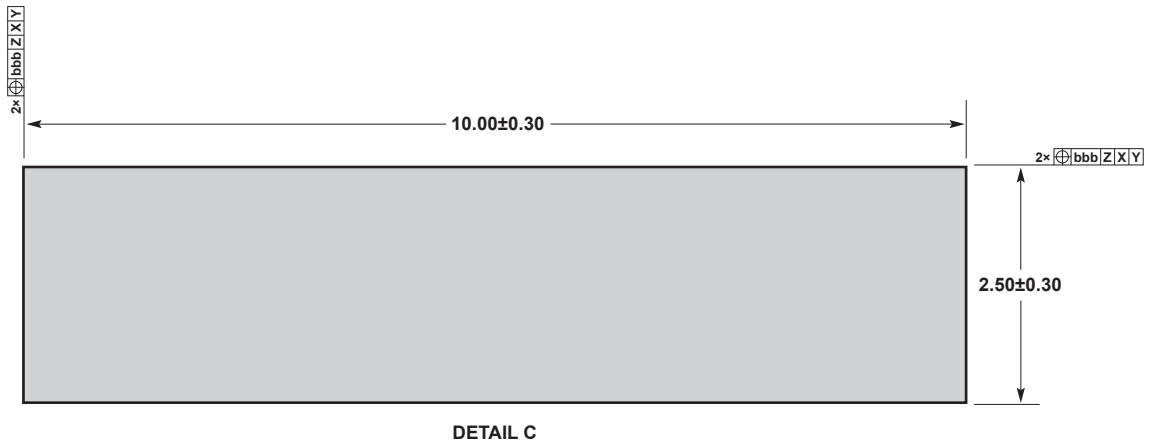
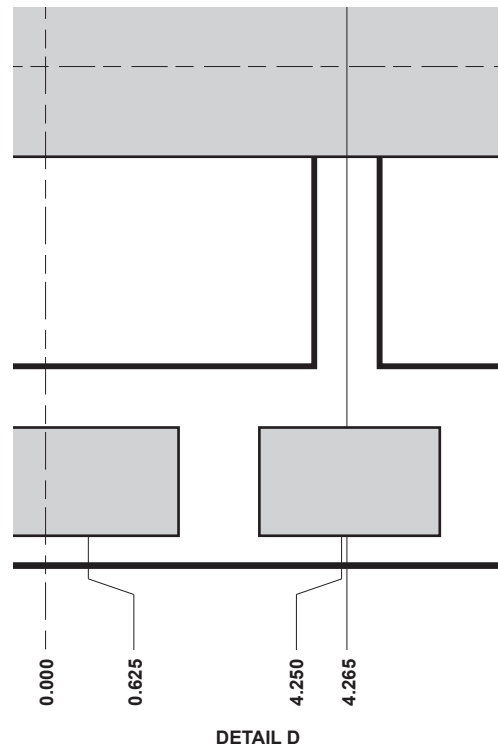
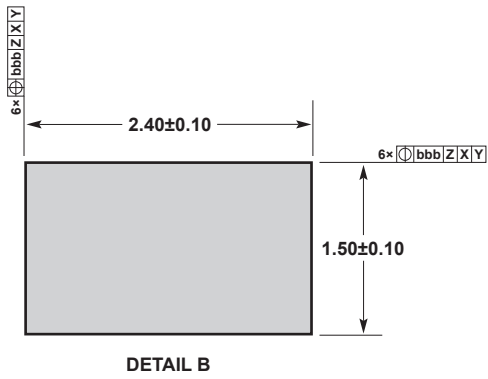
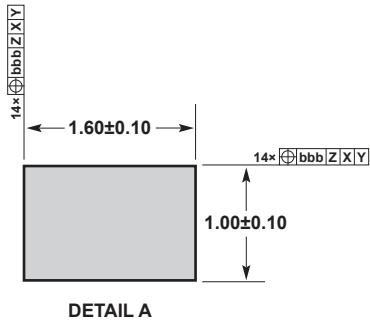

## REVISION HISTORY

REV	DATE	DESCRIPTION	PAGE NUMBER
0	11/23	Initial Release.	—
A	05/24	Updated URL to the link here.	11
		Updated units in Figure 6 and Figure 7.	13
B	01/26	Updated Electrical Characteristics table	4
		Updated SYNC (Pin 7) in Pin Functions section.	7

# LTP8802A-1B

## PACKAGE PHOTOS Part marking is either ink mark or laser mark

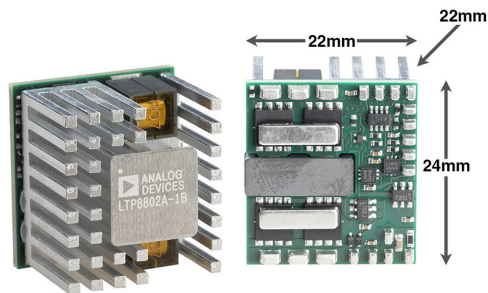

## DESIGN RESOURCES

SUBJECT	DESCRIPTION
<a href="#">µModule Design and Manufacturing Resources</a>	<p><b>Design:</b></p> <ul style="list-style-type: none"> <li>• Selector Guides</li> <li>• Demo Boards and Gerber Files</li> <li>• Free Simulation Tools</li> </ul> <p><b>Manufacturing:</b></p> <ul style="list-style-type: none"> <li>• Quick Start Guide</li> <li>• PCB Design, Assembly and Manufacturing Guidelines</li> <li>• Package and Board Level Reliability</li> </ul>
<a href="#">µModule Regulator Products Search</a>	<ol style="list-style-type: none"> <li>1. Sort table of products by parameters and download the result as a spread sheet.</li> <li>2. Search using the Quick Power Search parametric table.</li> </ol> <div style="border: 1px solid #ccc; padding: 5px; margin-top: 10px;"> <p><b>Quick Power Search</b></p> <p>INPUT   <math>V_{in}(\text{Min})</math> <input type="text"/> V <math>V_{in}(\text{Max})</math> <input type="text"/> V</p> <p>OUTPUT   <math>\pm</math> <math>V_{out}</math> <input type="text"/> V <math>I_{out}</math> <input type="text"/> A</p> <p>FEATURES   <input type="checkbox"/> Low EMI <input type="checkbox"/> Ultrathin <input type="checkbox"/> Internal Heat Sink</p> <p style="text-align: right;"><a href="#">Multiple Outputs</a> <a href="#">Search</a></p> </div>
<a href="#">Digital Power System Management</a>	Analog Devices' family of digital power supply management ICs are highly integrated solutions that offer essential functions, including power supply monitoring, supervision, margining and sequencing, and feature EEPROM for storing user configurations and fault logging.

## RELATED PARTS

PART NUMBER	DESCRIPTION	COMMENTS
<a href="#">LTP8800-1A</a>	54V <sub>IN</sub> , 150A Module Regulator with Digital Power System Management, Optimized for 0.8V <sub>OUT</sub>	45V ≤ V <sub>IN</sub> ≤ 65V, 0.5V ≤ V <sub>OUT</sub> ≤ 1.1V, PMBus with Control and Telemetry, ±0.5% of Maximum DC Output Error, 22mm × 24mm × 6.7mm Surface-Mount Package
<a href="#">LTP8800-4A</a>	54V <sub>IN</sub> , 200A Module Regulator with Digital Power System Management, Optimized for 0.8V <sub>OUT</sub>	45V ≤ V <sub>IN</sub> ≤ 65V, 0.5V ≤ V <sub>OUT</sub> ≤ 1.1V, PMBus with Control and Telemetry, ±0.5% of Maximum DC Output Error, 22mm × 24mm × 22mm Surface-Mount Package
<a href="#">LTP8803-1A</a>	54V <sub>IN</sub> , 160A Module Regulator with Digital Power System Management, Optimized for 1.2V <sub>OUT</sub>	45V ≤ V <sub>IN</sub> ≤ 65V, 0.5V ≤ V <sub>OUT</sub> ≤ 1.5V, PMBus with Control and Telemetry, ±0.5% of Maximum DC Output Error, 22mm × 24mm × 22mm Surface-Mount Package
<a href="#">LTM<sup>®</sup>4664A</a>	54V <sub>IN</sub> , Dual 30A or Single 60A µModule Regulator with Digital Power System Management	30V ≤ V <sub>IN</sub> ≤ 58V, 0.5V ≤ V <sub>OUT</sub> ≤ 1.2V, PMBus with Control and Telemetry, ±0.5% of Maximum DC Output Error, 16mm × 16mm × 7.72mm BGA Package
<a href="#">LTM4700</a>	Dual 50A or Single 100A µModule Regulator with Digital Power System Management	4.5V ≤ V <sub>IN</sub> ≤ 16V, 0.5V ≤ V <sub>OUT</sub> ≤ 1.8V, PMBus with Control and Telemetry, ±0.5% of Maximum DC Output Error, 15mm × 22mm × 7.87mm BGA Package
<a href="#">LTM4681</a>	Quad 31.25A or Single 125A µModule Regulator with Digital Power System Management	4.5V ≤ V <sub>IN</sub> ≤ 16V, 0.5V ≤ V <sub>OUT</sub> ≤ 3.3V, PMBus with Control and Telemetry, ±0.5% of Maximum DC Output Error, 15mm × 22mm × 8.17mm BGA Package
<a href="#">LTM4660</a>	60V, 300W Nonisolated µModule Bus Converter	30V ≤ V <sub>IN</sub> ≤ 60V, 7.5V ≤ V <sub>OUT</sub> ≤ 18V, Up to 300W, 16mm × 16mm × 10.34 BGA Package