

## FEATURES

- Cell voltage measurement
- Up to 16-cell channels
- Parallel and redundant architecture
- Passive cell balancing up to 300 mA per cell.
- <3 mV total measurement error (TME) at 4.2 V over the lifetime
- Pack current measurement.
  - Independent bidirectional channels with redundancy
  - Dedicated charge measurement/coulomb counter
  - Dynamic range:  $\pm 131$  mV
  - Resolution: 1  $\mu$ V/bit
  - Offset: 1  $\mu$ V over the lifetime
  - Gain Error: 0.1% over the lifetime.
- Synchronous pack current and cell voltage measurements
- Short/Over current detection
  - <2  $\mu$ s response time
  - Programmable detection time and threshold
  - Dedicated outputs for MOSFET/Contactor control
  - Redundant measurement, algorithm, and fault pin
- 10 General-purpose I/O (GPIO) channels
  - Cell and board temperature measurements
  - Pack, load, and system diagnostic measurements.
  - <3.3 mV TME over the lifetime
- Low power monitoring for key-off state
  - Dedicated fault output pin
  - Configurable overshoot, undershoot, and time gradient thresholds.
  - Cell voltage, pack current, and GPIO voltage measurement
  - Configurable measurable period
- Independent continuous time overcurrent protection
- 4-Wire SPI 4 MHz communication interface
- Package 64-pin QFN-SS
- AEC-Q100 qualified

## APPLICATIONS

- Mild hybrid electric vehicles
- Two-wheeler and three-wheeler electric vehicles
- Four-wheeler electric vehicle auxiliary battery
- Backup battery systems
- Energy storage systems (ESS)

## TYPICAL APPLICATION CIRCUIT

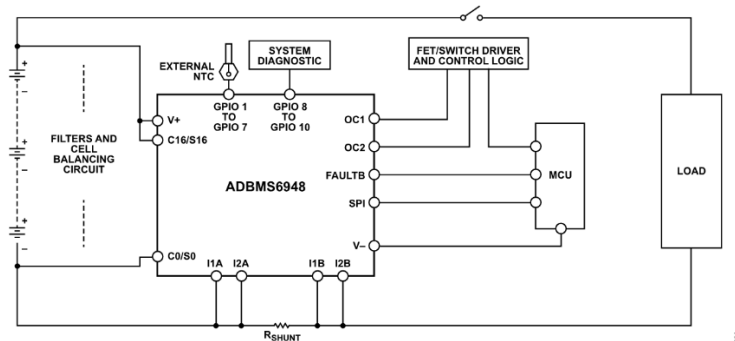

Figure 1. Typical Application Circuit Diagram

## FUNCTIONAL SAFETY

The ADBMS6948WFSCCSZM and ADBMS6948WFSCCSZ models are developed for use in ISO 26262 applications for Automotive Safety Integrity Level Capability C (ASIL C). Contact a local Analog Devices, Inc. sales office for the Product Safety Manual. The product safety manual provides information required for system integration, such as supported safety requirements, assumptions of use, safety mechanism implementation details, and fault metrics.

**NOTES**