



Blackfin® BF50x Processors: Powering the New Generation of Portable Medical Devices

Analog Devices' Blackfin® processors are an excellent fit for the requirements of many portable medical products such as electrocardiogram (ECG/EKG) devices, and automated external defibrillator (AED) devices. These applications are evolving toward greater portability, but are also incorporating more digital signal processing (DSP) functionality in order to provide increasing amounts of real-time processing. This processing power can be used to implement adaptive filtering, pacemaker detection, and ECG signal analysis for classification of cardiac rhythm information. The evolution of ECG and AED devices toward almost consumer-class products has put cost pressure and time to market constraints on the device manufacturers, and in many cases a digital approach to these filtering tasks makes sense.

In addition to addressing this signal processing challenge, Blackfin is able to fulfill the growing list of system tasks these ECG and AED devices are required to perform, including management of a rich user interface, audio playback, management of a network interface, and providing connectivity to PCs and bulk memory over USB. These increased DSP and system task workload requirements are ideally suited for Blackfin processors.

AED Requirements

AED devices are currently being deployed in public spaces and office buildings, commercial airliners, and emergency vehicles including ambulances, police cruisers and fire trucks. As these AED devices become more common outside of hospitals and medical facilities, their use by people with little to no medical training becomes the typical use-case. This key detail drives a need for these devices to be easy to use in a crisis situation by a passer-by who is unfamiliar with the device or defibrillator technology. System developers strive to build devices with these factors in mind, and in many cases opt to include audio prompts to the user as part of the system design. Coupled with the audio prompts are routines which assess the placement of the electrodes on the patient and evaluate not only the patient's status but whether the pads are well-placed. Some AED device developers are also using richer graphics over LCDs to illustrate important instructions such as electrode placement.

These devices also must have a long standby life, and for AED devices deployed in public spaces a battery life of over 5 years is not unheard of. Regular self-tests are run with lights or beepers, which activate when maintenance is needed. Even with laptop-class battery capacities, low running and standby power dissipation characteristics are a must.

ECG Requirements

ECG devices are commonplace in the healthcare industry, deployed mainly in the clinical environment. These devices vary in terms of application needs, ranging from smaller, low channel count devices in doctors' offices and clinics to high-end, high channel count devices intended for intensive care and surgical environments where interference from other instruments can be very challenging.

Portable ECG devices (aka Holter monitors) are also commonplace. These devices are worn or carried by a patient for an extended time (perhaps a few days) to gather a long term set of cardiac rhythm data. These portable devices have trended toward higher performance as well as toward better methods for storing and transmitting this ECG data. Older devices have been connected daily for a lengthy transmission of its captured data via a phone line to the healthcare provider. Newer devices can take advantage of wireless, Internet-based networking to provide a real-time data flow. Clinical ECG devices have also evolved in some cases to portable patient-worn or bedside devices that transmit the ECG waveform in real-time to a nurse's station.

The Need for Greater Processing Performance

As ECG devices become more portable and begin to include functions typically found only in clinical patient monitoring devices, more processing power is needed. This processing can be used to implement filtering of the ECG waveform to remove EMG artifacts (electromyogram-type signals from muscle contraction), noise and interference due to electrode movement, as well as pacemaker detection. It can be advantageous to implement a programmable pacemaker detection scheme with Blackfin rather than use a dedicated circuit in order to allow detection enhancements to keep pace with pacemaker evolution.

While pacemaker detection has become a necessary feature in clinical and portable ECG devices in the hospital setting, it's also necessary in AED devices, as the presence and type of implantable pacemaker or ICD (implantable cardioverter defibrillator, an implanted pacemaker device with defibrillator function) weighs on the decision whether to shock the patient. DSP algorithms can be readily developed and executed on high performance Blackfin processors to analyze and identify pacemakers and ICDs.

Additionally, ECG devices need to be able to react quickly when the patient is shocked with a defibrillator. Medical professionals need to see valid ECG data as soon as possible after the patient is shocked in order to have near real-time feedback on the efficacy of the shock event. Adaptive filtering techniques can be implemented using high-performance Blackfin processors to allow the system to provide ECG data very quickly following the shock, in contrast to less-capable MCUs or slower DSPs which would introduce a delay of several seconds. Blackfin's DSP capabilities and performance profile make the implementation of adaptive filtering possible.

Blackfin BF50x: Greater Processing Performance and Integrated System-level Functionality

ADI's new Blackfin BF50x processors are well-suited to DSP processing challenges in AED and ECG devices, delivering performance up to 400 MHz for high-speed signal processing and facilitating the

growing number of system tasks that are becoming more common in these devices, such as user interface management (often via an LCD/touch screen) and also connectivity tasks.

Blackfin BF50x processors offer optional integrated executable flash memory, which not only simplifies the bill of materials and decreases the PCB real estate, but also provides some inherent security in that the flash signals are not available outside of the package, ensuring that device manufacturers' software IP can be hidden from prying eyes. In addition, with shielding becoming more necessary to limit EMC and enhance ECG circuit performance, having an embedded flash within the processor often means less area to shield.

The Blackfin BF50x family enables excellent mixed-signal processing. The BF506 variant – with its in-package true 12-bit ADC – integrates high-quality analog signal acquisition and high-performance digital signal processing into a single package, thus achieving superior compactness. For applications where the optional in-package ADC is inappropriate, the ADC Control Module (ACM), which is available on all Blackfin BF50x processor variants, enables flexible interfacing to the broad range of Analog Devices' ADCs.

The Blackfin BF504F comes in a small footprint (12x12mm) package with integrated 4MB executable flash memory. The Blackfin BF506F provides a further level of system integration with an integrated 12-bit ADC (in addition to the 4MB flash) that delivers a very high effective resolution in a 14x14mm package. Whether a system designer chooses the BF504F with external ADC or the BF506F with integrated ADC, all Blackfin BF50x processors include an ADC Control Module (ACM) peripheral that synchronizes external event triggers with ADC sampling instances, making the timing of when the ADC samples very precise. The Blackfin BF50x family also provides low active and standby power dissipation, and power management modes to allow a flexible approach to conserving battery life.

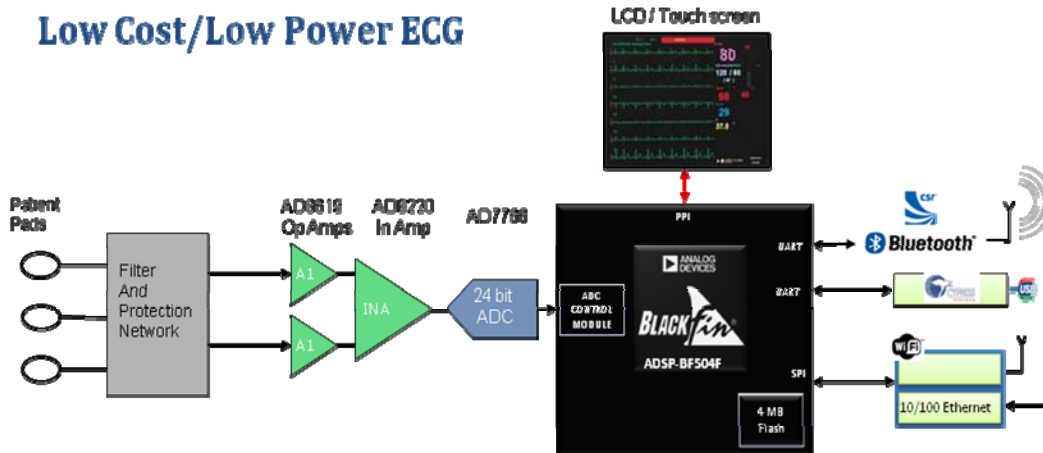

Blackfin processors offer a range of capabilities that are well suited to portable medical devices, and can provide other advanced features such as optional in-package, low-power stereo audio codec and optional on-chip USB 2.0 high-speed peripheral support. Delivering exceptional price/performance, robust connectivity and peripheral integration options, and low power attributes, Blackfin processors equip ECG and AED designers to achieve greater levels of signal processing precision, system functionality and reliability.

ADI Blackfin Fixed-Point Digital Signal Processors

Analog Devices' 16/32-bit fixed-point Blackfin digital signal processors are designed specifically to meet the computational demands and power constraints of today's embedded industrial, automotive, audio, video and consumer electronics applications. Blackfin processors deliver breakthrough performance and power efficiency with a RISC programming model, combining advanced signal processing functionality with the ease-of-use attributes found in general-purpose microcontrollers. This combination of processing attributes enables Blackfin processors to perform equally well in both signal processing and control processing applications - in many cases eliminating the requirement for separate heterogeneous processors. This capability greatly simplifies both the hardware and software design implementation tasks.

Comprehensive Development and Support Ecosystem

Analog Devices software and hardware development tools are designed to provide easier and more robust methods for engineers to develop and optimize systems, simplifying product development processes and reducing time to market. The Blackfin processor family leverages familiar development tools including the VisualDSP++® integrated development and debug environment (IDDE) and the EZ-Kit Lite® evaluation and application prototyping platform. A rich third-party software support network further enables developers to design more intelligent and efficient solutions for the industrial market.

For more information about ADI's full portfolio of digital signal processors, software, development tools and support, visit www.analog.com

