

Switches and Multiplexers

May 2007

Analog Devices, Inc., offers a large range of switches and multiplexers covering single to multiple switch elements, with various signal ranges, and in a variety of packages to best suit customer application needs.

Analog Devices switches can be classified into families when choosing based on supply voltage. The following families of parts exist:

- **ADG12xx**
 - ± 15 V low capacitance and Q_{INJ} switches and multiplexers
 - 2 pF off capacitances, <1 pC Q_{INJ}
- **ADG14xx**
 - ± 15 V low R_{ON} switches and multiplexers
 - 5 Ω max R_{ON} , 0.5 Ω R_{ON} flatness
- **ADG13xx**
 - ± 15 V low Q_{INJ} optimized switches and multiplexers
 - Optimized for standard applications
- **ADG2xx**
 - ± 15 V low capacitance and Q_{INJ} switches and multiplexers
 - $R_{ON} = 30 \Omega$ to 115 Ω , $Q_{INJ} = 10$ pC to 20 pC
- **ADG4xx**
 - ± 15 V low R_{ON} switches and multiplexers
 - $R_{ON} = 4 \Omega$ to 50 Ω , $Q_{INJ} = 1$ pC to 20 pC
- **ADG5xx**
 - ± 15 V and ± 5 V low capacitance and Q_{INJ} switches and multiplexers
 - $R_{ON} = 30 \Omega$ to 280 Ω , $Q_{INJ} = 4$ pC to 11 pC
- **ADG6xx**
 - ± 5 V low R_{ON} and low Q_{INJ} switches and multiplexers
 - $R_{ON} = 2 \Omega$ to 85 Ω , $Q_{INJ} = 0.5$ pC to 50 pC
- **ADG7xx**
 - Low voltage, low resistance switches
 - $R_{ON} = 2.2 \Omega$ to 15 Ω , $Q_{INJ} = 2$ pC to 14 pC
- **ADG8xx**
 - Low voltage, ultralow resistance switches
 - $R_{ON} = 0.25 \Omega$ to 1.3 Ω , $Q_{INJ} = 13$ pC to 200 pC
- **ADG9xx**
 - Low voltage, high frequency switches
 - 1.65 V to 2.75 V, 4.5 GHz CMOS switches
- **ADG3xxx**
 - Low voltage level translators (1.15 V up to 5.5 V)
 - Low voltage level translators
- **ADG21xx**
 - Unbuffered crosspoint switches
 - Dual- and single-supply I²C[®] controlled crosspoint switches

Switches and Multiplexers

May 2007

Function	Part Number	Features ¹	R _{on} Typ (Ω)	On Leakage Typ (nA)	Q _{on} Typ (pC)	Power Requirements (V _{nom})	I _{on} Typ (μ A)	Packaging ²	Price @ 1k (\$U.S.)
± 15 V Analog Switches and Multiplexers									
4:1	ADG1204	2 pF off cap, 1 pC Q _{on} , ± 15 V/12 V 4:1 mux	120	0.02	0.7	Single (12) or dual (+15, -15)	0.001	RU-14, CP-12-1	2.05
8:1	ADG428	On-chip address latches	60	1	4	Single (12) or dual (+15, -15)	20	N-18, R-18, P-20A, Q-18	3.14
8:1/diff 4:1	ADG408/ADG409	Single- and dual-supply operation, 44 V max, ADG408 available in TSSOP	40	1	20	Single (12) or dual (+15, -15)	1	N-16, R-16, Q-16, RU-16	2.48
8:1/diff 4:1	ADG1408/ADG1409	5 Ω max R _{on} , 4-/8-channel, ± 15 V, 12 V, ± 5 V mux	4	0.1	50	Single (12) or dual (+15, -15, ± 5)	0.002	RU-16, CP-16-13	2.96
8:1/diff 4:1	ADG508A/ADG509A	Single- and dual-supply operation, 44 V max supply rating	280	0.04	4	Single (12) or dual (+15, -15)	600	N-16, R-16, Q-16, R-16A, P-20A, E-20A	2.44
New	ADG528A/ADG529A	On-chip latches, single- and dual-supply, 44 V max supply rating	280	0.04	4	Single (12) or dual (+15, -15)	600	N-18, P-20A, Q-18	3.26
8:1/diff 4:1	ADG1208/ADG1209	1 pF off cap, 1 pC Q _{on} , ± 15 V/12 V mux	120	0.02	0.4	Single (12) or dual (+15, -15)	1	RU-16, CP-16-4	2.65
New	ADG1308/ADG1309	5 pF off cap, 2 pC Q _{on} , ± 15 V/12 V mux	130	1	2	Single (12) or dual (+15, -15)	0.002	RU-16, R-16	1.45
16:1	ADG426	Single- and dual-supply operation, on-chip latches	50	1	8	Single (12) or dual (+15, -15)	1	N-28, RS-28	5.36
16:1/diff 8:1	ADG406/ADG407	Single- and dual-supply operation, 44 V max supply rating	50	1	8	Single (12) or dual (+15, -15)	1	N-28, P-28A	5.54
16:1/diff 8:1	ADG506A/ADG507A	Single- and dual-supply operation, 44 V max supply rating	280	0.04	4	Single (12) or dual (+15, -15)	600	N-28, R-28, P-28A, Q-28, RU-28	5.41
16:1/diff 8:1	ADG526A/ADG527A	Single- and dual-supply operation, on-chip address latches	280	0.04	4	Single (12) or dual (+15, -15)	600	N-28, R-28, P-28A, Q-28	5.38
New	ADG1206/ADG1207	1.5 pF off cap, 0.5 pC Q _{on} , ± 15 V/12 V 16:1/diff 8:1 mux	120	0.08	0.5	Single (12) or dual (+15, -15)	1	RU-28, CP-32-2	4.31
SPST \times 1	ADG417	Low power, 35 μ W	25	0.1	7	Triple (+15, -15, +5) or multiple (12, 5)	0.0001	N-8, SO-8	1.02
New	ADG1201/ADG1202	1 pF off cap, 1 pC Q _{on} , ± 15 V/12 V SPST switches	120	0.02	0.3	Single (12) or dual (+15, -15)	0.001	RT-6	1.01
New	ADG1221/ADG1222/ ADG1223	1 pF off cap, 1 pC Q _{on} , ± 15 V/12 V dual SPST switches	120	0.02	0.3	Single (12) or dual (+15, -15)	0.001	RM-10	1.25
SPST \times 4	ADG201A/ADG202A	Single- and dual-supply operation, 44 V max supply rating	60	0.5	20	Dual (+15, -15)	600	N-16, R-16, P-16, R-16A, P-20A, Q-16, E-20A	1.62
SPST \times 4	ADG201HS	Fast switching time (50 ns), single- and dual-supply	30	0.1	10	Single (12 or 15) or dual (+15, -15)	10,000	N-16, R-16, Q-16, P-20A, E-20A	2.72
SPST \times 4	ADG211A/ADG212A	Single- and dual-supply operation, 44 V max supply rating	115	0.5	20	Triple (+15, -15, +5)	600	N-16, R-16A, P-20A	1.39
SPST \times 4	ADG1211/ADG1212/ ADG1213	2 pF off cap, 1 pC Q _{on} , ± 15 V/12 V quad SPST switches	120	0.02	0.3	Single (12) or dual (+15, -15)	0.001	RU-16, CP-16-3	1.92
SPST \times 4	ADG221/ADG222	Single- and dual-supply operation, 44 V max supply rating	60	0.5	20	Dual (+15, -15)	600	N-16, R-16, Q-16, P-20A, E-20A	1.49
SPST \times 4	ADG411/ADG412/ ADG413	Single- and dual-supply operation, 44 V max supply rating	25	0.1	5	Triple (+15, -15, +5) or multiple (12, 5)	0.0001	N-16, R-16A, Q-16, RU-16	1.95
SPST \times 4	ADG431/ADG432/ ADG433	Low leakage, low power (3.9 μ W)	17	0.1	5	Triple (+15, -15, +5) or multiple (12, 5)	0.0001	N-16, R-16A, R-16A2	1.95
SPST \times 4	ADG441/ADG442/ ADG444	Low charge injection, latch-up proof options	40	0.08	1	Triple (+15, -15, +5) or multiple (12, 5)	0.001	N-16, R-16	0.75
SPST \times 4	ADG451/ADG452/ ADG453	Lowest R _{on} switch at ± 15 V	4	0.04	20	Triple (+15, -15, +5) or multiple (12, 5)	0.0001	N-16, R-16, RU-16	1.95
New	ADG1311/ADG1312/ ADG1313	5 pF off cap, 2 pC Q _{on} , ± 15 V/12 V mux	130	10	2	Single (12) or dual (+15, -15)	0.001	RU-16, R-16	1.04
SPDT \times 1	ADG419	Low power, 35 μ W	25	0.4		Triple (+15, -15, +5) or multiple (12, 5)	0.0001	N-8, SO-8, RM-8, Q-8	1.28
New	ADG1219	1.3 pF off cap, 1 pC Q _{on} , ± 15 V/12 V SPDT switches	120	0.02	1	Single (12) or dual (+15, -15)	0.001	RJ-8	0.93
SPDT \times 2	ADG436	Low R _{on}	12	0.05	10	Single (12) or dual (+15, -15)	50	N-16, R-16	2.31
SPDT \times 2	ADG1236	2 pF off cap, 1 pC Q _{on} , ± 15 V/12 V dual SPDT switch	120	0.02	1	Single (12) or dual (+15, -15)	0.001	RU-16, CP-12-1	1.92
New	ADG1433/ADG1434	4 Ω R _{on} , 0.5 Ω R _{off} , flatness, single- and dual-supply operation	4	0.05	50	Single (12) or dual (+15, -15)	0.001	RU-16, RU-20, CP-16-4, CP-20-1	2.52/3.26
New	ADG1233/ADG1234	1 pF off cap, 1 pC Q _{on} , ± 15 V/12 V triple/quad SPDT switches	120	1	0.5	Single (12) or dual (+15, -15)	1	RU-16, CP-16-4	2.27/2.92
New	ADG1334	5 pF off cap, 2 pC Q _{on} , ± 15 V/12 V mux	130	10	2	Single (12) or dual (+15, -15)	0.002	RS-20	1.60
SPDT \times 4	ADG333A	Single- and dual-supply operation, available in 20-lead SSOP	20	0.1	2	Single (12) or dual (+15, -15)	50	N-20, R-20, RS-20	2.73
± 15 V with Overvoltage/Fault Protection									
8:1/diff 4:1	ADG438F/ADG439F	-40 V to +55 V overvoltage protection, latch-up proof	250	0.01	4	Dual (+15, -15)	50	N-16, R-16	3.64
8:1/diff 4:1	ADG508F/ADG509F	-40 V to +55 V overvoltage protection, latch-up proof	300	0.04	4	Dual (+15, -15)	10	N-16, R-16	3.27
8:1	ADG528F	On-chip latches, -40 V to +55 V overvoltage protection, latch-up proof	300	0.04	4	Dual (+15, -15)	10	N-18, P-20A	3.86
Channel protector \times 1	ADG465	Single channel protector, 6-lead SOT-23, 40 V protection, latch-up proof	80	0.2		Dual (+15, -15)	0.05	RT-6, RM-8	0.75
Channel protector \times 8	ADG467	Octal channel protector, packages include SSOP, latch-up proof	60	0.2		Dual (+15, -15)	0.05	R-18, RS-20	2.15

Function	Part Number	Features ¹	R _{on} Typ (Ω)	On Leakage Typ (nA)	Q _{on} Typ (pC)	Power Requirements (V _{min})	I _{on} Typ (μ A)	Packaging ²	Price @ 1k (\$U.S.)
± 5 V Analog Switches and Multiplexers									
4:1	AD6604	1 pC charge injection, low leakage 4:1 mux, 5 V or ± 5 V supplies +3 V, +5 V, ± 5 V power supplies, -40°C to $+85^\circ\text{C}$ in TSSOP Low voltage CMOS 4-channel and 8-channel multiplexers Low distortion, break before make/make before break, 8-lead SOT, 8-lead MSOP Low distortion, low R _{on} , NO and NC in 6-lead SOT-23, and 8-lead MSOP 1 pC charge injection, low leakage, 14-lead TSSOP Low distortion, low R _{on} , NO, NC, and NO/NC in 10-lead MSOP CMOS ± 5 V/ ± 5 V/ ± 3 V triple SPDT switch +3 V, +5 V, ± 5 V supplies, NO, NC, and 2 NO/NC +5 V or ± 5 V supplies, NO, NC, and 2 NO/NC 1 pC charge injection, low leakage, NO, NC, and 2 NO/NC in 16-lead TSSOP	85	0.01	1	Single (2.7 to 5.5) or dual (± 5)	0.001	RU-14	1.55
8:1/diff 4:1	AD6608/AD6609		22	0.05	6	Single (3 or 5) or dual (± 5 , -5)	0.05	N-16, R-16, RU-16	1.79
8:1/diff 4:1	AD6658/AD6659		45	0.005	2	Single (12) or dual (± 5)	0.01	RU-16, CP-16, RQ-16	0.85
SPDT \times 1	AD6619/AD6620		4	0.01	110	Single (2.7 to 5.5) or dual (± 5)	0.001	RJ-8, RM-8	0.94
SPST \times 1	AD6601/AD6602		2	0.01	250	Single (2.7 to 5.5) or dual (± 5)	0.001	RM-8, RJ-8, CSURF	0.89
SPDT \times 2	AD6636		85	0.01	1.2	Single (2.7 to 5.5) or dual (± 5)	0.001	RU-14	1.55
SPST \times 2	AD6621/AD6622/ AD6623		4	0.01	110	Single (2.7 to 5.5) or dual (± 5)	0.001	RM-10	0.94
SPDT \times 3	AD6633		52	0.005	2	Single (12) or dual (± 5)	0.01	RU-16, CP-16	0.85
SPST \times 4	AD6511/AD6512/ AD6513		30	0.05	11	Single (3.3 or 5) or dual (± 5)	0.0001	N-16, R-16A, Q-16	2.04
SPST \times 4	AD6661/AD6662/ AD6663		30	0.05	6	Single (5) or dual (± 5)	0.0001	RU-16	2.04
SPST \times 4	AD6611/AD6612/ AD6613	85	0.01	0.5	Single (2.7 to 5.5) or dual (± 5)	0.001	RU-16	1.45	
Low Voltage Analog Switches and Multiplexers (Single- and Dual-Supply)									
Dual 2:1 mux	AD6787	2.5 Ω CMOS, low power, dual 2:1 USB1.1 switch	2.5	0.05	14	Single (1.8 to 5.5)	0.005	CP-10, CB-10, RM-10	0.92
4:1	AD6704	4:1 multiplexers in 10-lead MSOP	2.5	0.01	3	Single (1.8 to 5.5)	0.001	RM-10	0.95
3 \times 3:1 mux	AD6793A/AD6793G	I ² C-compatible, wide bandwidth, triple 3:1 multiplexer	2.6	0.25	5	Single (3 or 5)	1	CP-24-2	1.74
4:1	AD6804	<0.8 Ω , CMOS 1.6 V to 3.6 V, 4-channel multiplexers	0.5	0.1	28	Single (1.6 to 3.6)	0.003	RM-10	0.98
3 \times 4:1	AD6792A/AD6792G	I ² C-compatible, wide bandwidth, triple 4:1 multiplexer	2.6	0.25	5	Single (3 or 5)	1	CP-24-2	2.17
8:1/diff 4:1	AD6708/AD6709	3 Ω CMOS multiplexers with parallel interface in TSSOP package	3	0.01	3	Single (1.8 to 5.5) or dual (± 2.5)	0.001	RU-16	1.25
8:1/diff 4:1	AD6758/AD6759	3 Ω CMOS multiplexers with parallel interface in 20-lead LFCSOP package	3	0.01	3	Single (1.8 to 5.5) or dual (± 2.5)	0.001	CP-20	1.25
8:1/dual 4:1	AD6728/AD6729	Individually configurable matrix switch, I ² C-compatible serial interface	2.5	0.01	3	Single (2.7 to 5.5)	10	RU-16	1.6
8:1/dual 4:1	AD6738/AD6739	Individually configurable matrix switch, SPI-compatible serial interface	2.5	0.01	3	Single (2.7 to 5.5)	10	RU-16	1.6
16:1/diff 8:1	AD6706/AD6707	2.5 Ω , CMOS multiplexers with parallel interface	2.5	0.01	5	Single (1.8 to 5.5) or dual (± 2.5)	0.001	RU-28	2.55
32:1/diff-dual 16:1	AD6726/AD6732	32:1/diff-dual 16:1 multiplexers with parallel interface	4	0.05	5	Single (1.8 to 5.5) or dual (± 2.5)	10	CP-48, SU-48	4.51
32:1/diff-dual 16:1	AD6725/AD6731	32:1/diff-dual, 16:1 multiplexers with SPI-compatible interface	4	0.05	5	Single (1.8 to 5.5) or dual (± 2.5)	10	CP-48, SU-48	4.59
New	AD6790	Low voltage, CMOS multimedia switch	3.9	10	6.2	Single (1.65 to 3.6)	0.1	CB-30	2.64
	AD6801/AD6802	Single-supply, rated to 125°C , NO and NC, 400 mA current handling	0.25	0.01	50	Single (1.8 to 5.5)	0.001	RT-6, RM-8	0.9
SPST \times 1	AD6701/AD6702L	Single-supply, 1.8 V to 5.5 V in 6-lead SOT-23 and 8-lead MSOP	2	0.01	5	Single (1.8 to 5.5)	0.001	RT-6, RM-8, RJ-5	0.6
SPST \times 1	AD6741/AD6742	Single-supply, 1.8 V to 5.5 V in 6-lead SC70	2	0.01	5	Single (1.8 to 5.5)	0.001	KS-6, KS-5	0.65
SPST \times 1	AD6751	RF/video switch, -3 dB BW 300 MHz, -75 dB off isolation at 100 MHz	15	0.01	15	Single (1.8 to 5.5)	0.001	RM-8, RT-6	0.9
SPST \times 2	AD6821/AD6822/ AD6823	Single-supply, rated to 125°C , 200 mA current handling	0.5	0.01	15	Single (1.8 to 5.5)	0.001	RM-8	1.02
SPST \times 2	AD6721/AD6722/ AD6723	Low R _{on} , low voltage single-supply in 8-lead MSOP (NO, NC, and NO/NC)	2.5	0.01	2	Single (1.8 to 5.5)	0.001	RM-8	0.65
SPST \times 4	AD6711/AD6712/ AD6713	Single-supply, 1.8 V to 5.5 V in 16-lead TSSOP, and SOIC (NO, NC, and 2 NO/NC)	2.5	0.01	3	Single (1.8 to 5.5)	0.001	RU-16, R-16	0.9
SPST \times 4	AD6781/AD6782/ AD6783	Single-supply, 1.8 V to 5.5 V in 20-lead CSP (NO, NC, and 2 NO/NC)	2.5	0.01	3	Single (1.8 to 5.5)	0.001	CP-20	0.9
SPST \times 8	AD6714	3-wire serial interface (SPI-/QSPI TM -/MICROWIRE TM -compatible interface)	2.5	0.01	3	Single (2.7 to 5.5) or dual (± 2.5)	10	RU-24	1.75
SPST \times 8	AD6715	2-wire serial interface (I ² C-compatible interface)	2.5	0.01	3	Single (2.7 to 5.5) or dual (± 2.5)	10	RU-24	1.75
SPDT \times 1	AD6841/AD6842	0.35 Ω CMOS, single SPDT	0.28	0.2	200	Single (1.65 to 3.6)	0.003	KS-6	0.57
SPDT \times 1	AD6819/AD6820	Single-supply, rated to 125°C , also available in MSOP	0.5	0.01	20	Single (1.8 to 5.5)	0.001	RT-6, RM-8, CB-6	0.93
SPDT \times 1	AD6849	3 V/5 V CMOS, 0.5 Ω SPDT in SC70	0.5	0.04	50	Single (1.8 to 5.5)	0.001	KS-6	0.64
SPDT \times 1	AD6859	3 V/5 V CMOS, SPDT/2:1 mux in SOT-66	1.3	0.02	13	Single (1.8 to 5.5)	0.001	RY-6	0.6
SPDT \times 1	AD6811/AD6812/ AD6813	<0.8 Ω CMOS, 1.65 V to 3.6 V quad SPST	0.5	0.2	30	Single (1.6 to 3.6)	0.003	RU-16	1.22
SPDT \times 1	AD6719	Single-supply, 1.8 V to 5.5 V in 6-lead SOT-23, 8-lead MSOP	2.5	0.01	15	Single (1.8 to 5.5)	0.001	RT-6, RM-8	0.65
SPDT \times 1	AD6752	RF/video switch, -3 dB BW, 250 MHz, -80 dB off isolation at 30 MHz	15	0.01	15	Single (1.8 to 5.5)	0.001	RT-6, RM-8	1.17
SPDT \times 1	AD6749	Single-supply, 1.8 V to 5.5 V in SC70 package	2.5	0.01	2	Single (1.8 to 5.5)	0.001	KS-6	0.7
SPDT \times 1	AD6779	Low cost, single-supply, 1.8 V to 5.5 V in SC70 package	2.5	0.01	2	Single (1.8 to 5.5)	0.001	KS-6	0.64
SPDT \times 2	AD6836	<0.8 Ω CMOS, 1.6 V to 3.6 V dual SPDT	0.5	0.2	40	Single (1.6 to 3.6)	0.003	RM-10, CP-12	0.98
SPDT \times 2/dual 2:1 mux	AD6884	0.5 Ω CMOS, dual 2:1 mux/SPDT audio switch	0.28	0.2	125	Single (1.8 to 5.5)	0.003	CP-10, CB-10, RM-10	0.9
SPDT \times 2	AD6736	Low voltage, single-supply in 10-lead MSOP	2.5	0.01	15	Single (1.8 to 5.5)	0.001	RM-10	0.9

Function	Part Number	Features ¹	R _{on} Typ (Ω)	On Leakage Typ (nA)	Q _{on} Typ (pC)	Power Requirements (V _{max})	I _{on} Typ (μ A)	Packaging ²	Price @ 1k (\$U.S.)
SPDT \times 3	AD6733	Triple channel SPDT with single- and dual-supply	2.5	0.01	3	Single (1.8 to 5.5) or dual (\pm 2.5)	0.001	RU-16, RQ-16	1.1
SPDT \times 3	AD6786	Triple channel SPDT, single- and dual-supply in 20-lead CSP	2.5	0.01	3	Single (1.8 to 5.5) or dual (\pm 2.5)	0.001	CP-20	1.1
SPDT \times 4	AD6734	Single- and dual-supply, independent control to each switch	2.5	0.01	3	Single (1.8 to 5.5) or dual (\pm 2.5)	0.001	RU-20	1.35
SPDT \times 4	AD6788	Single- and dual-supply, independent control to each switch, 20-lead CSP	2.5	0.01	3	Single (1.8 to 5.5) or dual (\pm 2.5)	0.001	CP-20	1.35
SPDT \times 4	AD6774	Single-supply, 2.7 V to 5.5 V with common switch control	2.2	0.01	7	Single (1.8 to 5.5)	0.001	R-16, RQ-16	1.45
SPDT \times 4	AD6774A	High speed 400 MHz, 3 ns switch time, with common switch control	2.2	0.001	6	Single (1.8 to 5.5)	0.001	RQ-16, CP-16-3	1.49
SPDT \times 4	AD6794	300 MHz bandwidth, single 3 V/5 V supply, TTL-/CMOS-compatible	5	0.001	7.5	Single (3 or 5)	0.001	RQ-16	1.23
SPDT \times 4	AD6784	Single-supply, 2.7 V to 5.5 V with common switch control, 20-lead CSP	2.2	0.01	10	Single (1.8 to 5.5)	0.001	CP-20	1.45
SPDT \times 4	AD6791/AD6791G	fC-compatible, wide bandwidth, 4-channel SPDT switch	2.6	0.25	5	Single (3 or 5)	1	CP-24-2	0.69
SPDT \times 4	AD6795/AD6795G	fC-compatible, wide bandwidth, 5-channel SPDT	2.6	0.25	5	Single (3 or 5)	1	CP-24-2	0.96
SPDT \times 6	AD6796A	fC-compatible, wide bandwidth, 6-channel SPDT	2.6	0.25	5	Single (3 or 5)	1	CP-24-2	1.13
DPDT \times 2, SPDT \times 4	AD6888	0.4 Ω CMOS, 1.8 V to 5.5 V dual DPDT switch	0.4	0.2	70	Single (1.8 to 5.5)	0.003	RU-16, CP-16-4, CB-16	1.6
Unbuffered Analog Crosspoint Switch Arrays									
New									
New	AD62108	8 \times 10, fC-compatible unbuffered switch array with single and dual operation	30	0.03	3.5	Single (12) or dual (\pm 5)	0.05	CP-32-2	4.91
New	AD62128	8 \times 12, fC-compatible unbuffered switch array with single and dual operation	30	0.03	3.5	Single (12) or dual (\pm 5)	0.05	CP-32-3	6.29
New	AD62188	8 \times 8, fC-compatible unbuffered switch array with single and dual operation	30	0.03	3.5	Single (12) or dual (\pm 5)	0.05	CP-32-2	4.21
New	AD6799/AD6799G	fC-compatible, wide bandwidth, triple 2 \times 2 crosspoint switch	2.6	0.25	5	Single (3 or 5)	1	CP-24-2	1.33
Bus Switches/Level Translators									
2:1 \times 4, level shift	AD63257	3.3 V/5 V, quad 2:1 multiplexer-demultiplexer, industry-standard pinout	2	100	5	Single (3.3 to 5)	0.001	RQ-16	0.59
1-bit, 2-port	AD63241	2.5 V/3.3 V, 1-bit, 2-port level translator bus switch	4.5	225	3.2	Single (2.3 to 3.6)	0.01	KS-6, RY-6-1	0.43
2-bit, 2-port	AD63242	2.5 V/3.3 V, 2-bit, common control level translator, bus switch	4.5	225	3.2	Single (2.3 to 3.6)	0.01	RJ-8, CHIP	0.56
2-bit, 2-port	AD63243	2.5 V/3.3 V, 2-bit, individual control level translator, bus switch	4.5	225	3.2	Single (2.3 to 3.6)	0.01	RJ-8	0.56
2:1, level shift	AD63248	2.5 V/3.3 V, 2:1 mux/level translator in SC70	4.5	225	3.2	Single (2.3 to 3.6)	0.01	KS-6	0.56
2:1, level shift	AD63249	2.5 V/3.3 V, 2:1 mux/level translator with level shift select and bus enable	4.5	225	3.2	Single (2.3 to 3.6)	0.01	RJ-8	0.56
8-bit, 2-port	AD63245	8-bit, 2-port bus switch with 3.3 V to 2.5 V/1.8 V selectable level shift	4.5	225	3.2	Single (2.3 to 3.3)	0.01	RU-20, CP-20	0.71
10-bit, 2-port	AD63246	10-bit, 2-port bus switch with 3.3 V to 2.5 V/1.8 V selectable level shift	4.5	225	3.2	Single (2.3 to 3.3)	0.01	RU-24, CP-24	0.74
16-bit, 2-/3-/8-bit, 2-port	AD63247	Dual, 8-bit, 2-port bus switch with 3.3 V to 2.5 V/1.8 V selectable level shift	4.5	225	3.2	Single (2.3 to 3.3)	0.01	RU-38, CP-40	0.98
Bypass/level shift	AD63233	Digital bypass switch with bidirectional 1.65 V to 3.6 V level shift	N/A	3500	4	Single (1.65 to 3.6)	2	RM-8, RJ-8	0.57
2:1, level shift	AD63232	Low voltage 2:1 multiplexer level translator	N/A	3500	4	Single (1.65 to 3.6)	2	RJ-8	0.52
Level shift	AD63231	Low voltage single-channel level translator	N/A	4000	N/A	Single (1.65 to 3.6)	2	RJ-6, RY-6-1	0.43
Low voltage, 8-bit bidirectional level translator	AD63300	Bidirectional level translation, operates from 1.15 V to 5.5 V, low quiescent current < 1 μ A	N/A	5000	1000	Single (1.15 to 5.5)	0.27	RU-20	1.6
Low voltage, 4-bit bidirectional level translator	AD63304	Bidirectional level translation, operates from 1.15 V to 5.5 V, low quiescent current < 1 μ A	N/A	5000	1000	Single (1.15 to 5.5)	0.27	RU-14, CB-12, CP-20-1	0.96
Low voltage, 8-bit bidirectional level translator	AD63308/AD63308-1	Bidirectional level translation, operates from 1.15 V to 5.5 V, low quiescent current < 1 μ A	N/A	5000	1000	Single (1.15 to 5.5)	0.27	RU-20, CP-20-1, CB-20-2	1.6
Low voltage, 1-bit bidirectional level translator	AD63301	Bidirectional single channel 1.15 V to 5.5 V level translation	N/A	5000	1000	Single (1.15 to 5.5)	0.27	KS-6	0.46
Low voltage, 8-bit CMOS to HV level translator	AD63123	CMOS logic to HV level translation, input voltage range 2.3 V to 5.5 V with -24.4 V to +35 V output	N/A	80,000	N/A	Dual (10.8 to 3.5/0 to -24.2)	65	RU-20	2.3
Industry-Leading High Bandwidth CMOS Switches (Low Voltage, Single-Supply)									
SPDT \times 1	AD6901/AD6902	Wideband, 37 dB isolation at 1 GHz, CMOS 1.65 V to 2.75 V, abs/reff switches	37 dB (1 GHz)	0.8 dB (1 GHz)	16	Single (1.65 to 2.75)	0.1	RM-8, CP-8	1.03
SPDT \times 1	AD6918/AD6919	Wideband, 37 dB isolation at 1 GHz, CMOS 1.65 V to 2.75 V, 2:1 mux/SPDT switches	37 dB (1 GHz)	0.8 dB (1 GHz)	16	Single (1.65 to 2.75)	0.1	RM-8, CP-8	1.07
SPDT \times 2	AD6936/AD6936-R	Wideband, 4 GHz, 36 dB isolation at 1 GHz, CMOS 1.65 V to 2.75 V, dual SPDT	36 dB (1 GHz)	0.9 dB (1 GHz)	16	Single (1.65 to 2.75)	0.1	RU-20, CP-20-1	1.52
4:1	AD6904/AD6904-R	Wideband, 2.5 GHz, 37 dB isolation at 1 GHz, CMOS 1.65 V to 2.75 V, 4:1 mux	37 dB (1 GHz)	1.1 dB (1 GHz)	16	Single (1.65 to 2.75)	0.1	RU-20, CP-20-1	1.52

¹NO = normally open; NC = normally closed; SPST = single-pole, single-throw; SPDT = single-pole, double-throw (2:1 mux)

²CB = solder bumped WLCSP; KS = SC70; N = DIP; H = SOIC; P = PLCC; Q = CerDip; RS = SSOP; RJ = TSSOP; RT/RJ = SOT or SOT-8; RM = MSOP; RQ = GSOP; CP = fCSP; SU = TOFP; RY = SOT-66

L = Guaranteed leakage performance

Choosing the Correct Switch or Multiplexer for Your Application

Supply voltage, configuration, performance, and package are the key specifications in choosing the correct switch for your application. As an individual switch cannot be optimized in all respects, Analog Devices offers a large and varied selection of options that cover differing supply voltages, configurations, high performance, and industry-leading package sizes.

Supply Voltage

Depending on the supply voltage that you require, Analog Devices can offer you a number of high performance switches and multiplexers to suit your application. Low voltage switches can offer performance advantages over higher voltage switches. High voltage switches are optimized when using the maximum signal range but are specified for use at lower voltages also. Analog Devices offers a varied range of supply voltages:

- ± 15 V
- ± 5 V
- Low voltage (up to 5 V)
- Single- and dual-supply options

Configuration

Do you need a switch or a multiplexer? If a switch, do you need a SPST or an SPDT? How many channels do you need? What interface do you require?

- I²C: 2-wire digital interface—SCL (clock) and SDA (data).
- SPI: 3-wire serial interface— $\overline{\text{SYNC}}$, DATA, SCLK.
- Parallel: Simple digital interface. Logic high/low on the pin dictates the state of the switch.

Package

All Analog Devices switches are offered in a number of different package options, offering up to 75% saving on board space vs. the competition. Details of these package options can be seen in the selection table and information on package sizes are also shown.

Technical Support and Sales

Applications engineers are available by phone or email to discuss any queries with regard to any of our switches. Details can be found on our website at www.analog.com. Samples are available for all our switches and can be requested through our local sales offices.

Analog Switch Performance

Parameter	Definition	Indicator	ADI Specifications
On resistance	Resistance of the closed switch path	Lower is better	0.25 Ω to 300 Ω
Charge injection	Disturbance to signal from control input	Lower is better	0.3 pC to 200 pC
Supply voltage	Voltage of the analog switch circuit	Must be bigger than signal amplitude	1.15 V to 20 V ± 5 V to ± 20 V
Bandwidth	AC performance of the on-state switch	Higher is better	DC to 4 GHz
Isolation	AC performance of the off-state switch	Higher is better	<90 dB
Leakage	Leakage currents into/out of a switch channel	Lower is better	<200 nA

Examples of Some of the Package Types Available

Package	Lead Count Options	Example Body Size (mm)	Example Board Area (sq mm)	Example Pitch (mm)	Package Code
TSSOP	14/16/20/24/28/38	5.0 × 4.4 × 0.65 (14-lead)	32 (14-lead)	0.65 (14-lead)	RU-X ²
MSOP	8/10	3.0 × 3.0 × 1.1 (8-lead)	14.7 (8-lead)	0.65 (8-lead)	RM-X ²
LFCSP	8/10/12/16/20/24/32/40/48	3.0 × 3.0 × 0.9 (8-lead)	9 (8-lead)	0.65 (8-lead)	CP-X ²
SOT-23	5/6/8	2.9 × 1.6 × 1.175 (5-lead)	8.12 (5-lead)	0.95 (5-lead)	RT/RJ-X ²
SC70	5/6	1.25 × 2.0 × 0.65 (5-lead)	4.2 (5-lead)	0.65 (5-lead)	KS-X ²
SOT-66	6	1.66 × 1.2 × 0.57 (6-lead)	2.74 (6-lead)	0.5 (6-lead)	RY-X ²
Mini LFCSP	10/16	1.3 × 1.6 × 0.6 (10-lead)	2.08 (10-lead)	0.4 (10-lead)	CP-X ²
WLCSP ¹	5/6/10/12/16	0.9 × 1.29 × 0.5 (5-lead)	1.16 (5-lead)	0.5 (5-lead)	CB-X ²

¹Dimensions dependent by part.
²"-X" denotes number of leads.

Common Switch and Multiplexer Configurations

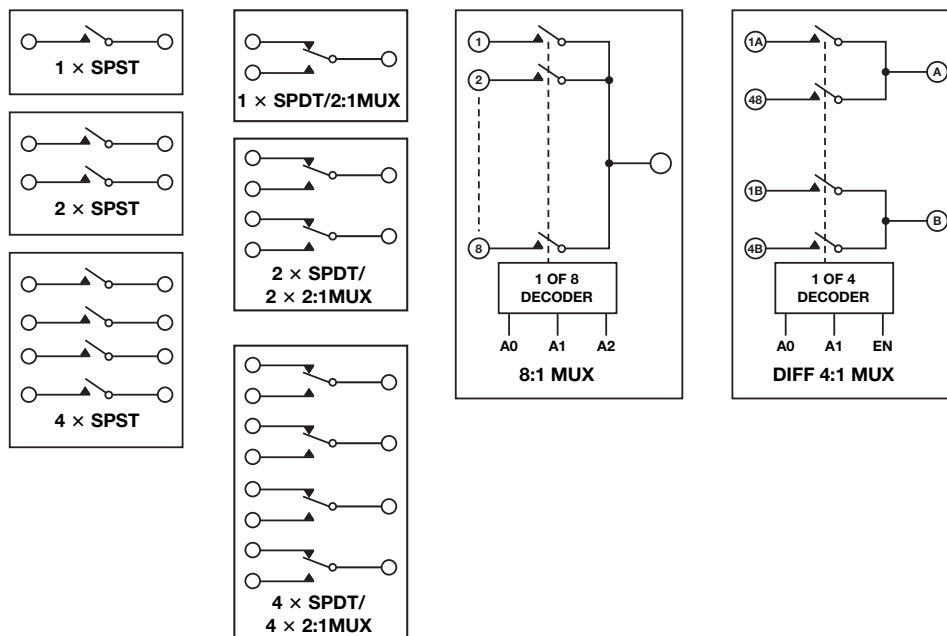

Purchase of licensed I²C components of Analog Devices or one of its sublicensed Associated Companies conveys a license for the purchaser under the Philips I²C Patent Rights to use these components in an I²C system, provided that the system conforms to the I²C Standard Specification as defined by Philips.

For more information on ADI switches and multiplexers, visit our website at www.analog.com/switch-mux.