

Look what 40 years of analog leadership does for power management ICs.

Our newest voltage monitoring and sequencing innovations

±0.8% Accurate Quad Voltage Monitors ADM1184 and ADM1186

Industry leading accuracy and a high level of functional integration in tiny packages. Additional functionality in the ADM1186; includes the ability to perform up/down sequencing.

Dual and Triple Supervisors ADM13305 and ADM13307

Ten models in 8-lead SOIC packages, with options for pretrimmed undervoltage threshold, adjustable inputs, and watchdog timers.

Compact Multivoltage Sequencers and Supervisors ADM1062 to ADM1069

Programmable devices for multiple supply systems; integrated 12-bit ADC and four 8-bit voltage output DACs for power supply margining.

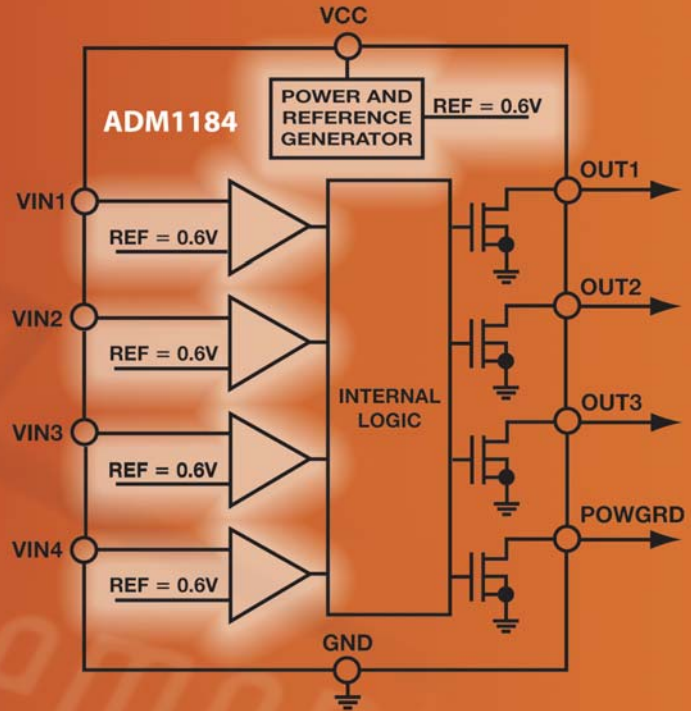

±0.8% accurate monitors and sequencers that give your customers safer, more reliable operation.

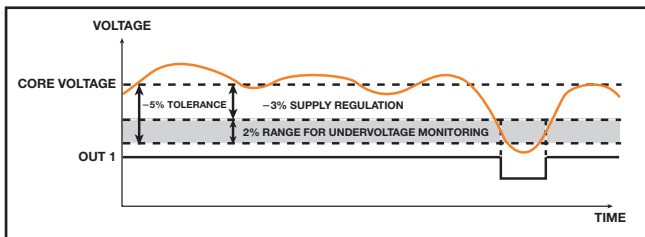

Industry's Best Threshold Accuracy, 2 to 12 Supplies

High accuracy is critical when monitoring low voltage cores. With up to 2× the accuracy over temperature of competitive parts, these ADI products offer the ability to maintain a much tighter voltage tolerance, thereby maximizing system protection.

For years, engineers have relied on our analog and mixed-signal ICs to enable their telecommunications, data communications, medical, and instrumentation designs. See how we are applying this design expertise to power management, delivering solutions that not only provide best-in-class functionality, but also improve the performance of your analog circuit. Case in point: the ADM1184, integrating ADI's ±0.8% accurate voltage reference technology, offers best-in-class accuracy to prevent data loss and failures in high performance applications.

See what 40 years of analog leadership can do for your power designs. Email ADI's power technical support at power.management@analog.com.