



Evaluation Kits for ADM1186 Quad Sequencer and Monitor

EVAL-ADM1186

FEATURES

- 4 on-board variables supplies with LEDs to show status LEDs to show power good, fault, and sequence done (main evaluation kits only)**
- Switchable capacitors to set time delays (main evaluation kits only)**
- Manual fault push switch**
- Single step mode**
- Multiple boards can be cascaded for more than four supplies (EVAL-ADM1186-1EBZ only)**

PRODUCT DESCRIPTION

The ADM1186-1 and ADM1186-2 can be used to turn on and off four supplies in sequence under the control of a state machine, and can monitor the supplies to ensure that they are above a user defined undervoltage (UV) threshold. If any supply drops below the UV threshold, a fault occurs and the state machine turns all the supplies off.

GENERAL DESCRIPTION

There are two types of evaluation kits for the ADM1186-1 and ADM1186-2. The main evaluation boards are intended for standalone operation of the devices with just an external mains power supply. They provide all the on-board supplies, controls,

and status indicators necessary to operate the device. The micro-evaluation boards are intended to allow the ADM118-1 or ADM1186-2 to be easily used as part of a bench prototype, and include the minimal set of components.

The evaluation kits for each device allow a user to perform controlled up and down sequences of four supplies. The main evaluation kits allow simulated fault conditions on each on-board supply or on a control signal. All kits provide the ability to single-step and observe the behavior of the state machine during the power-up and power-down sequence.

A single ADM1186-1 can control four supplies, but it is possible to join multiple devices and boards together to support cascaded up and down sequences of eight, 12, or more supplies. The main ADM1186-1 evaluation board supports a daisy-chain connection to demonstrate this feature.

EVALUATION KIT CONTENTS

The EVAL-ADM1186-1EBZ and EVAL-ADM1186-2EBZ evaluation kits contain an evaluation board, along with some samples of the ADM1186-1 or the ADM1186-2 parts.

The EVAL-ADM1186-1MBZ and EVAL-ADM1186-2MBZ micro-evaluation kits contain only an evaluation board.

For all types of evaluation kit, an ADM1186-1 or ADM1186-2 device is present and soldered to the board.

Rev. 0

Evaluation boards are only intended for device evaluation and not for production purposes. Evaluation boards are supplied "as is" and without warranties of any kind, express, implied, or statutory including, but not limited to, any implied warranty of merchantability or fitness for a particular purpose. No license is granted by implication or otherwise under any patents or other intellectual property by application or use of evaluation boards. Information furnished by Analog Devices is believed to be accurate and reliable. However, no responsibility is assumed by Analog Devices for its use, nor for any infringements of patents or other rights of third parties that may result from its use. Analog Devices reserves the right to change devices or specifications at any time without notice. Trademarks and registered trademarks are the property of their respective owners. Evaluation boards are not authorized to be used in life support devices or systems.

FUNCTIONAL BLOCK DIAGRAMS

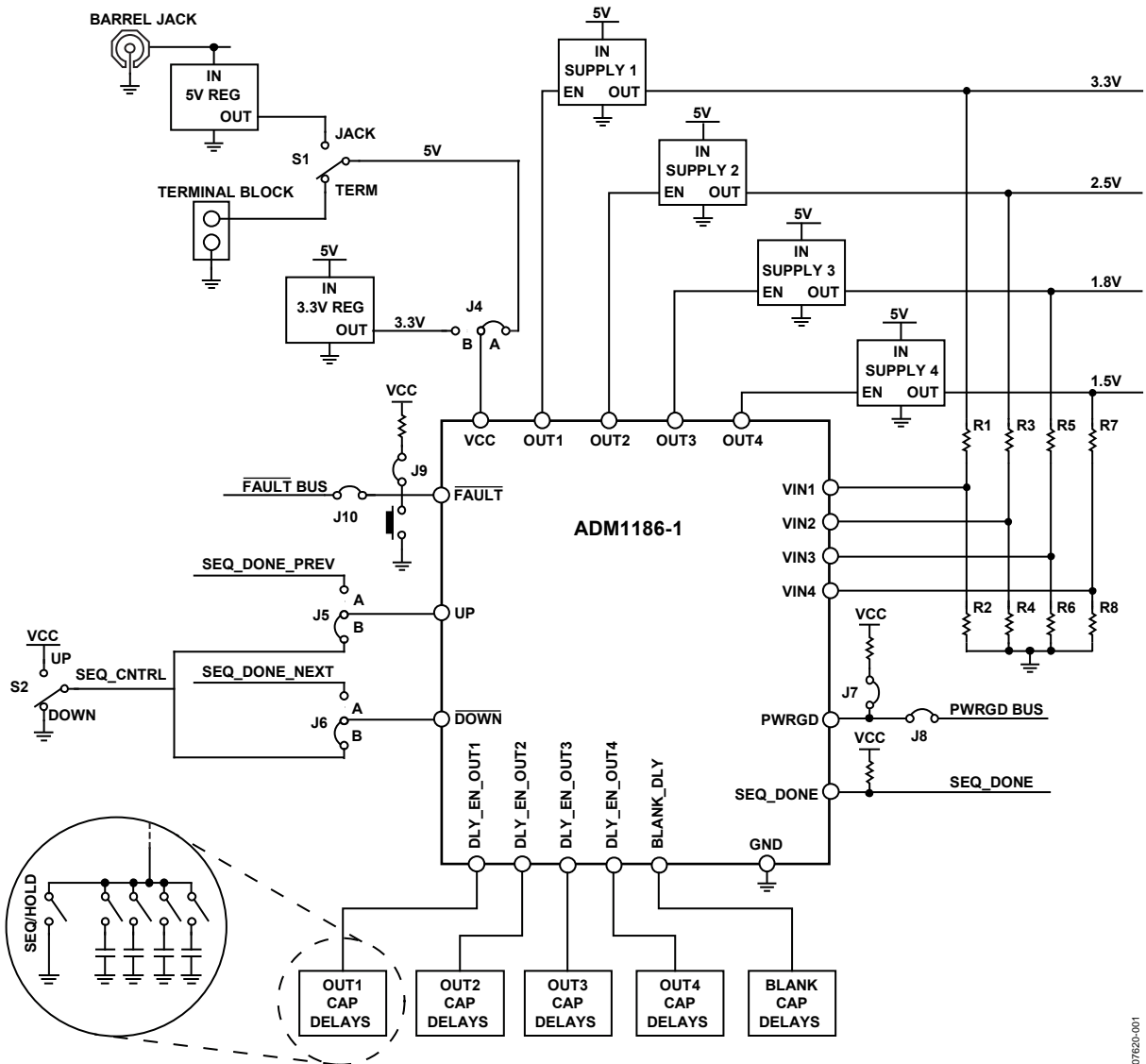

Figure 1. ADM1186-1 Evaluation Board

07630-001

EVAL-ADM1186

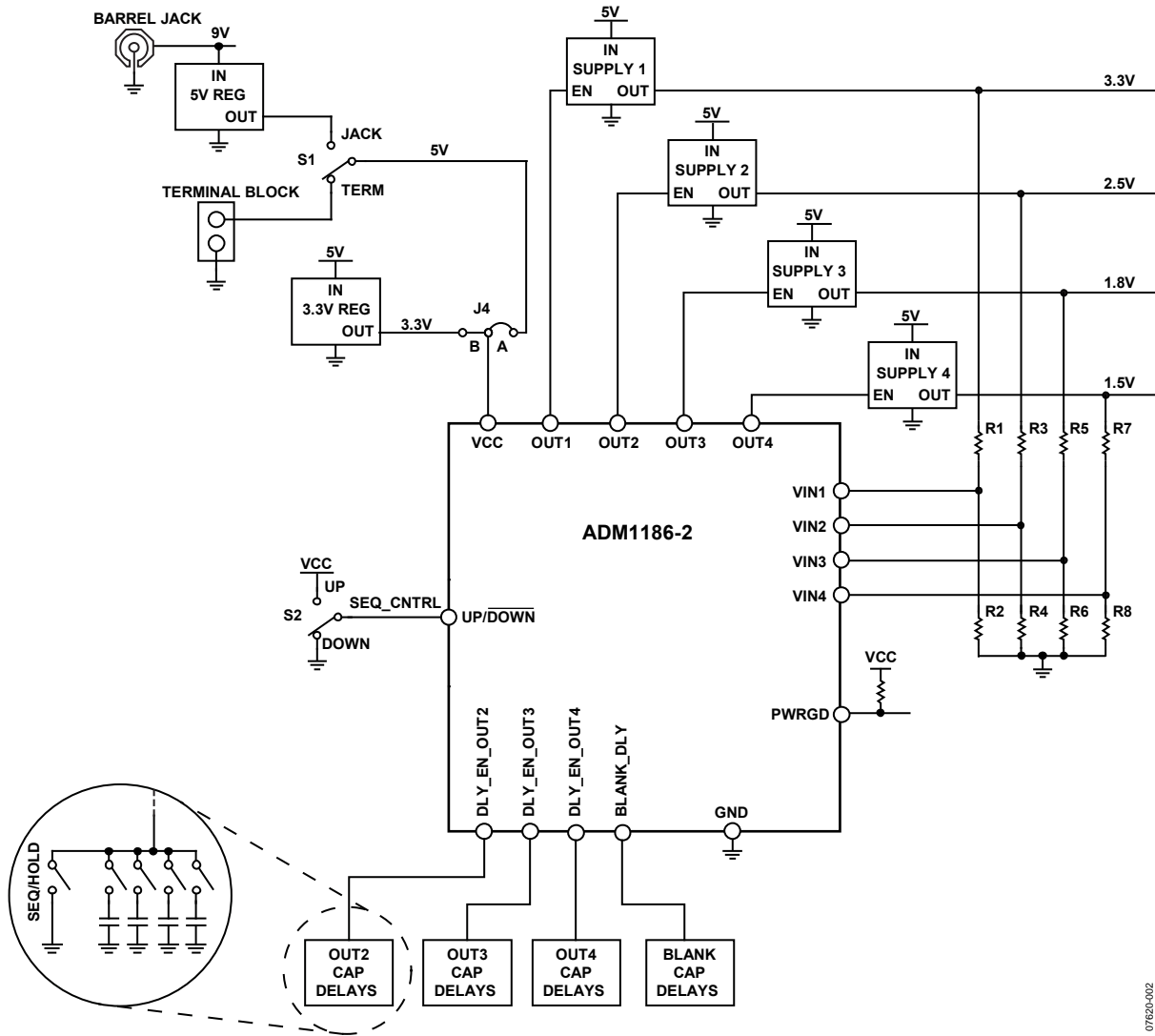

Figure 2. ADM1186-2 Evaluation Board

07620-002

EVALUATION BOARD HARDWARE

EVALUATION BOARD CONNECTOR, SWITCH, JUMPER, LED, AND TEST POINT FUNCTIONS

Table 1. Connector Functions

Reference	Name	Function
J1	Terminal block	J1-1: Connects the a positive terminal of a 5 V bench supply to the board J1-2: Connects the ground terminal of a bench supply to the board
J2	Cascade pin header	Connects to the previous board when interconnecting ADM1186-1 boards in cascade (EVAL-ADM1186-1EBZ only)
J3	DC barrel jack	J3-Outer: Connects the a positive terminal of a 9 V supply to the board J3-Center: Connects the ground terminal of a supply to the board
J11	Cascade socket header	Connects to the next board when interconnecting ADM1186-1 boards in cascade (EVAL-ADM1186-1EBZ only)

Table 2. Switch Functions

Reference	Description	Position	Function
S1	Switch to select power source	Jack Term	Selects dc barrel jack as power source Selects terminal block as power source
S2	Sequence control	Up Down	Connects the UP and $\overline{\text{DOWN}}$ pins to the ADM1186 supply Connects the UP and $\overline{\text{DOWN}}$ pins to ground
S3	Delay 1 control (EVAL-ADM1186-1EBZ only)	Hold Seq	Connects the DLY_EN_OUT1 pin to ground to pause the state machine No connection to the DLY_EN_OUT1 pin, no effect on the state machine
S4	Delay 2 control	Hold Seq	Connects the DLY_EN_OUT2 pin to ground to pause the state machine No connection to the DLY_EN_OUT2 pin, no effect on the state machine
S5	Delay 3 control	Hold Seq	Connects the DLY_EN_OUT3 pin to ground to pause the state machine No connection to the DLY_EN_OUT3 pin, no effect on the state machine
S6	Delay 4 control	Hold Seq	Connects the DLY_EN_OUT4 pin to ground to pause the state machine No connection to the DLY_EN_OUT4 pin, no effect on the state machine
S7	Blanking delay control	Hold Seq	Connects the BLANK_DLY pin to ground to pause the state machine No connection to the BLANK_DLY pin, no effect on the state machine
S8	Sets time delay associated with the 3.3 V supply (EVAL-ADM1186-1EBZ only)	S8-1 S8-2 S8-3 S8-4	Connects C9 and C5 (user-defined) between the DLY_EN_OUT1 pin and ground Connects C8 (1 μF) between the DLY_EN_OUT1 pin and ground Connects C7 (100 nF) between the DLY_EN_OUT1 pin and ground Connects C2 (1 nF) between the DLY_EN_OUT1 pin and ground
S9	Sets time delay associated with the 2.5 V supply	S9-1 S9-2 S9-3 S9-4	Connects C21 and C14 (user-defined) between the DLY_EN_OUT2 pin and ground Connects C17 (1 μF) between the DLY_EN_OUT2 pin and ground Connects C15 (100 nF) between the DLY_EN_OUT2 pin and ground Connects C12 (1 nF) between the DLY_EN_OUT2 pin and ground
S10	Sets time delay associated with the 1.8 V supply	S10-1 S10-2 S10-3 S10-4	Connects C35 and C24 (user-defined) between the DLY_EN_OUT3 pin and ground Connects C27 (1 μF) between the DLY_EN_OUT3 pin and ground Connects C25 (100 nF) between the DLY_EN_OUT3 pin and ground Connects C23 (1 nF) between the DLY_EN_OUT3 pin and ground
S11	Sets time delay associated with the 1.5 V supply	S11-1 S11-2 S11-3 S11-4	Connects C36 and C31 (user-defined) between the DLY_EN_OUT4 pin and ground Connects C30 (1 μF) between the DLY_EN_OUT4 pin and ground Connects C29 (100 nF) between the DLY_EN_OUT4 pin and ground Connects C28 (1 nF) between the DLY_EN_OUT4 pin and ground
S12	Sets time delay associated with the blanking time	S12-1 S12-2 S12-3 S12-4	Connects C41 and C38 (user-defined) between the DLY_EN_OUT4 pin and ground Connects C40 (1 μF) between the DLY_EN_OUT4 pin and ground Connects C39 (100 nF) between the DLY_EN_OUT4 pin and ground Connects C37 (1 nF) between the DLY_EN_OUT4 pin and ground

EVAL-ADM1186

Reference	Description	Position	Function
S13	Manual fault switch (EVAL-ADM1186-1EBZ only)	Pressed	Connects the $\overline{\text{FAULT}}$ line to ground
VR1	3.3 V adjust	N/A	Reduces the 3.3 V supply voltage when the switch is turned counterclockwise
VR2	2.5 V adjust	N/A	Reduces the 2.5 V supply voltage when the switch is turned counterclockwise
VR3	1.8 V adjust	N/A	Reduces the 1.8 V supply voltage when the switch is turned counterclockwise
VR4	1.5 V adjust	N/A	Reduces the 1.5 V supply voltage when the switch is turned counterclockwise

Table 3. Jumper Functions

Reference	Description	Default
J4	J4-A: Connects the VCC pin to a 5 V supply J4-B: Connects the VCC pin to a 3.3 V supply	J4-A
J5	J5-A: Connects the UP pin to the SEQ_DONE signal of the previous board in cascade J5-B: Connects the UP pin to Switch S2 if the first board in cascade or a single standalone board (EVAL-ADM1186-1EBZ only)	J5-B
J6	J6-A: Connects the $\overline{\text{DOWN}}$ pin to the SEQ_DONE signal of the next board in cascade J6-B: Connects the DOWN pin to Switch S2 if the last board in cascade or a single standalone board (EVAL-ADM1186-1EBZ only)	J6-B
J7	Connects PWRGD to a VCC supply via 10 k Ω pull-up resistor (EVAL-ADM1186-1EBZ only)	Fitted
J8	Connects the PWRGD pin to the PWRGD bus in cascade operation (EVAL-ADM1186-1EBZ only)	Fitted
J9	Connects the $\overline{\text{FAULT}}$ pin to VCC supply via 10 k Ω pull-up resistor (EVAL-ADM1186-1EBZ only)	Fitted
J10	Connects the FAULT pin to the FAULT bus in cascade operation (EVAL-ADM1186-1EBZ only)	Fitted

Table 4. LED Functions

Reference	Name	Function
D1	5 V board supply	The green LED indicates the status of the main 5 V supply rail
D2	3.3 V ADM1186 supply	The green LED indicates the status of the ADM1186 3.3 V supply rail
D3	3.3 V variable supply	The green LED indicates the status of the variable 3.3 V supply rail
D4	2.5 V variable supply	The green LED indicates the status of the variable 2.5 V supply rail
D5	1.8 V variable supply	The green LED indicates the status of the variable 1.8 V supply rail
D6	1.5 V variable supply	The green LED indicates the status of the variable 1.5 V supply rail
D7	PWRGD	The green LED indicates when the PWRGD pin is asserted high
D8	SEQ_DONE (EVAL-ADM1186-1EBZ only)	The green LED indicates when the SEQ_DONE pin is asserted high
D9	$\overline{\text{FAULT}}$ (EVAL-ADM1186-1EBZ only)	The red LED indicates when the $\overline{\text{FAULT}}$ pin is asserted low

Table 5. Test Point Functions

Reference	Function
5V0B	Monitors the voltage at the 5 V regulator output or input to J1-1 depending on position of Switch S1
3V3B	Monitors the voltage at the output of the 3.3 V ADM1186 regulator
3_3V	Monitors the voltage at the output of the 3.3 V variable regulator
2_5V	Monitors the voltage at the output of the 2.5 V variable regulator
1_8V	Monitors the voltage at the output of the 1.8 V variable regulator
1_5V	Monitors the voltage at the output of the 1.5 V variable regulator
VIN1	Monitors the voltage at the VIN1 pin
VIN2	Monitors the voltage at the VIN2 pin
VIN3	Monitors the voltage at the VIN3 pin
VIN4	Monitors the voltage at the VIN4 pin
UP	Monitors the voltage at the UP pin (EVAL-ADM1186-1EBZ only)
/DOWN	Monitors the voltage at the $\overline{\text{DOWN}}$ pin (EVAL-ADM1186-1EBZ only)
UP/DOWN	Monitors the voltage at the UP/ $\overline{\text{DOWN}}$ pin (EVAL-ADM1186-2EBZ only)
OUT1	Monitors the voltage at the OUT1 pin
OUT2	Monitors the voltage at the OUT2 pin
OUT3	Monitors the voltage at the OUT3 pin
OUT4	Monitors the voltage at the OUT4 pin
PWRGD	Monitors the voltage at the PWRGD pin
SEQ_DONE	Monitors the voltage at the SEQ_DONE pin (EVAL-ADM1186-1EBZ only)
/FAULT	Monitors the voltage at the $\overline{\text{FAULT}}$ pin (EVAL-ADM1186-1EBZ only)
DLY1	Monitors the voltage at the DLY_EN_OUT1 pin (EVAL-ADM1186-1EBZ only)
DLY2	Monitors the voltage at the DLY_EN_OUT2 pin
DLY3	Monitors the voltage at the DLY_EN_OUT3 pin
DLY4	Monitors the voltage at the DLY_EN_OUT4 pin
BLNK	Monitors the voltage at the BLANK_DLY pin
SEQ_DONE_NEXT	Monitors the voltage at the SEQ_DONE pin of the next ADM1186-1 device in cascade (EVAL-ADM1186-1EBZ only)
SEQ_DONE_PREV	Monitors the voltage at the SEQ_DONE pin of the previous ADM1186-1 device in cascade (EVAL-ADM1186-1EBZ only)
SEQ_CNTRL_A	Monitors the voltage on the sequence control bus in cascade (EVAL-ADM1186-1EBZ only)
SEQ_CNTRL_B	Monitors the same voltage as SEQ_CNTRL_A (EVAL-ADM1186-1EBZ only)
GND1	Ground terminal
GND2	Ground terminal

EVAL-ADM1186

MICRO-EVALUATION BOARD SWITCH FUNCTIONS

Table 6. ADM1186-1MBZ Switch Functions

Reference	Description	Position	Function
S1	Single stepping and fault generation	S1-1	Delay 1 control; when on, connects the DLY_EN_OUT1 pin to ground to pause state machine
		S1-2	Delay 2 control; when on, connects the DLY_EN_OUT2 pin to ground to pause state machine
		S1-3	Delay 3 control; when on, connects the DLY_EN_OUT3 pin to ground to pause state machine
		S1-4	Delay 4 control; when on, connects the DLY_EN_OUT4 pin to ground to pause state machine
		S1-5	Blanking delay control; when on, connects the BLANK_DLY pin to ground to pause state machine
		S1-6	Fault generation; when on, holds the $\overline{\text{FAULT}}$ line low

Table 7. ADM1186-2MBZ Switch Functions

Reference	Description	Position	Function
S1	Single stepping	S1-1	Delay 2 control; when on, connects the DLY_EN_OUT2 pin to ground to pause state machine
		S1-2	Delay 3 control; when on, connects the DLY_EN_OUT3 pin to ground to pause state machine
		S1-3	Delay 4 control; when on, connects the DLY_EN_OUT4 pin to ground to pause state machine
		S1-4	Blanking delay control; when on, connects the BLANK_DLY pin to ground to pause state machine

EVALUATION BOARD OPERATION

POWER REQUIREMENT

The evaluation board requires a supply rail of 5 V, which can be provided in one of two ways: either a dc supply of 5 V can be directly connected to the terminal block, J1 with polarity as marked on the PCB, or a 9 V dc supply can be connected to the J3 barrel jack connector, which is then regulated down. The center of the barrel jack connector is ground.

A switch, S1, selects which of the two supply options (jack or term) is used by the board. At no time should a supply connection be made to both J1 and J3.

When multiple EVAL-ADM1186-1EBZ boards are cascaded together, power needs to be applied to a single board. Switch S1 must be set to the same position on all boards, depending on whether the terminal block or barrel jack is in use. This should be done before power is connected.

GETTING STARTED

This section demonstrates the basic operation of a main evaluation board, performing a simple up and down sequence. The detailed operation and configuration of the board is covered in the following sections.

To configure a single board to perform an up and down sequence, use the following steps:

1. Set S2 to the down position. Set the S3 to S7 switches to the Seq position. S3 is present only on EVAL-ADM1186-1EBZ. Set switch banks S8 to S12 such that only Switch Position 2 on each bank of switches is on. S8 is present only on EVAL-ADM1186-1EBZ.
2. On EVAL-ADM1186-1EBZ, ensure that jumpers are fitted on J8 to J10.
3. Ensure that jumpers are fitted in positions J4-A, J5-B, and J6-B. Only J4 is present on EVAL-ADM1186-2EBZ.
4. Turn VR1 to VR4 so that they are fully clockwise.
5. Connect an appropriate supply to either J1 or J3 and set Switch S1 accordingly.

The D1 and D2 LEDs should be on. Change Switch S2 to the up position to start an up sequence. The four supplies turn on, shown by LEDs D3 to D6. The PWRGD (power good) and SEQ_DONE (sequence done) LEDs, D7 and D8, are also turned on at the end of the up sequence. Setting S2 to down reverses the sequence, turning off the LEDs.

Setting Voltage-Detection Levels

The input pins, VIN1 to VIN4, monitor one of four supply voltages. The VIN1 pin monitors the 3.3 V rail. An external resistor divider scales this voltage down for monitoring at the VIN1 pin. The resistor ratio has been chosen so that the VIN1 voltage is 0.6 V when the 3.3 V rail is 5% below its nominal value. For example, if R1 is 100 k Ω and R2 is 23.7 k Ω , a voltage level of 3.13 V corresponds to 0.6 V at the VIN1 pin, as shown in Figure 3.

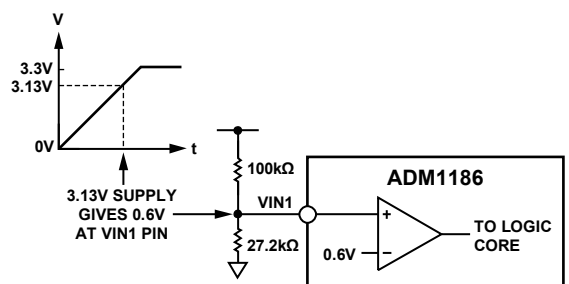

Figure 3. Setting the Undervoltage Threshold with an External Resistor Divider

Board Supplies

The board supply of 5 V is used to generate the four rails monitored by VIN1 to VIN2. The four other rails are nominally 3.3 V, 2.5 V, 1.8 V, and 1.5 V, but can be varied by about $\pm 10\%$ using the variable resistors VR1 to VR4, respectively. This range is sufficient to allow the user to set a supply above or below the UV level to simulate undervoltage faults during a sequence or once powered on.

Capacitor Timing and Single Stepping

The ADM1186-1 provides five timing pins, four used for sequence delays and one for a blanking time. The ADM1186-2 provides four timing pins, three used for sequence delays and one for a blanking time. A capacitor on each pin sets the time delay for a given state during an up or a down sequence.

The evaluation boards provide three fixed value capacitors for each sequence delay that can be individually switched in or out, as required, using S8 to S11 (S8 is found only on EVAL-ADM1186-1EBZ). The capacitor values fitted are 10 nF, 100 nF, and 1 μ F, giving approximate delay times of 1 ms, 10 ms, and 100 ms.

The evaluation boards provide three fixed value capacitors for the blanking delay that can be individually switched in or out, as required, using S12. The capacitor values fitted are 10 nF, 47 nF, and 100 nF, giving approximate delay times of 1 ms, 5 ms, and 10 ms.

EVAL-ADM1186

There is also provision for user capacitors to be fitted to the board that may be switched in for additional sequence or blanking delay time options. For all capacitors, the duration of the time delay is defined by the following formula:

$$t_{DELAY} = C_{DELAY} \times 0.1$$

where:

t_{DELAY} is the time delay in seconds.

C_{DELAY} is the capacitor value in microfarads.

Associated with each group of capacitors on a timing pin is a switch that can be used to hold the state machine in a specific state. This function allows the user to single-step through an up or down sequence, and manually control when the next state change occurs.

The S3 to S7 switches are set to the sequence position for normal operation (S3 is found only on the EVAL-ADM1186-1EBZ). Setting a switch to the hold position grounds the timing pin, preventing the capacitor from charging and effectively pausing the state machine.

Refer to the relevant state machine diagram in the ADM1186 data sheet for the details of when the capacitors are used during the power-up and power-down sequences.

Manual Fault Generation

The EVAL-ADM1186-1EBZ provides a push switch, S13, that can be used to generate a fault condition by bringing the FAULT line low for as long as the switch is pressed. While S13 is pressed, the D9 LED is lit to indicate a fault condition.

The delay control switches can be used to pause the state machine and examine its behavior under various fault conditions. For example, setting the Delay 2 control switch to hold prevents the state machine from advancing to the ENABLE OUT2 state. This allows a user to simulate a UV condition on the 3.3 V supply in the Delay 2 state that is otherwise difficult to achieve.

CASCADING MULTIPLE BOARDS

The ADM1186-1 provides additional pins and functionality that enable multiple devices to be cascaded, while still maintaining a controlled power-up and power-down sequence.

The EVAL-ADM1186-1EBZ supports the cascading of multiple boards so that the behavior of multiple ADM1186-1 parts controlling eight, 12, 16, or more supplies can be demonstrated.

The J2 and J11 connectors are used to daisy-chain the EVAL-ADM1186-1EBZ boards to cascade multiple devices. When connecting the boards together the order is important as this sets the place in the power-up/power-down sequence. The pinouts for the two connectors used for cascading boards are shown in Figure 4.

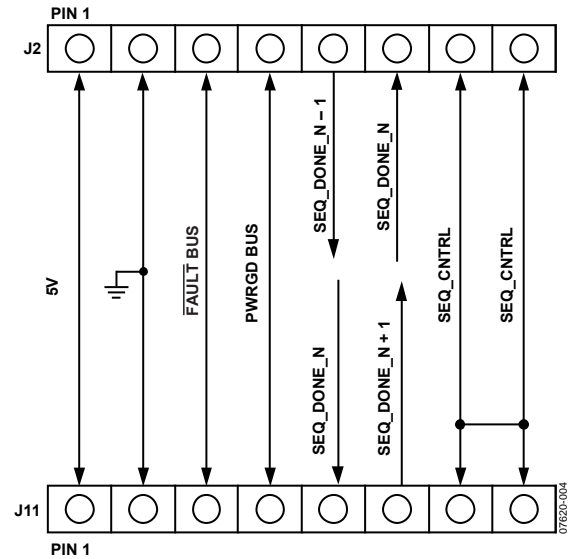

Figure 4. Pin Connections for the Cascade Connectors on Board N

Figure 5 shows how boards should be connected in cascade and the order in which the twelve supplies are turned on, from 1 to 12. In the power down sequence, the order is reversed so Supply 12 is turned off first and Supply 1 is turned off last.

There is a pair of jumpers on EVAL-ADM1186-1EBZ that needs to be set to connect the sequence up and down control signals. Jumper J5 and Jumper J6 should be set according to Table 3. For example, Board A would have J5 in Position B and J6 in Position A. When all boards are configured, Switch S2 on Board A is able to control the up and down sequence for all cascaded boards.

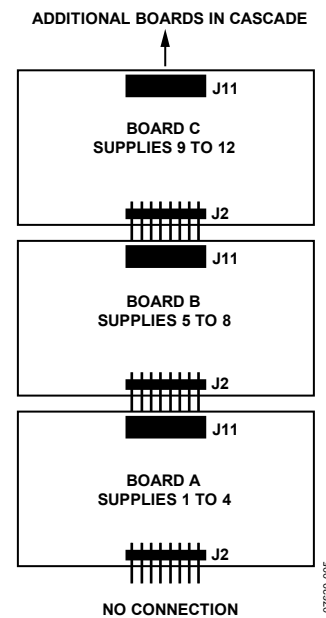

Figure 5. Connecting Multiple EVAL-ADM1186-1EBZs in Cascade

Jumper J8 and Jumper J10 allow the isolation of the PWRGD and FAULT signals to individual boards. When the jumpers are fitted, the PWRGD or FAULT signals of each board are connected to the PWRGD or FAULT bus.

If the PWRGD signals from all the boards are joined to the PWRGD bus, then the PWRGD signal is active only if all supplies are above their UV threshold levels.

If the FAULT signals are all joined to the FAULT bus, a fault on any one board causes all other devices to enter their fault handler states as well. When multiple ADM1186-1 parts are used in cascade, their FAULT pins are typically connected together to ensure that the power-up and power-down sequence works correctly.

Finally, Jumper J7 and Jumper J9 are used to connect pull-up resistors to the PWRGD and FAULT pins on each board. The pull-up resistors are connected to the VCC supply rail, selected by J4, for a given ADM1186-1. If multiple PWRGD or FAULT pins are connected together, particularly if the ADM1186-1 devices are being powered from different supply voltages, then only one J7 or J9 jumper should be fitted on all the boards in cascade.

MICRO-EVALUATION BOARD

The micro-evaluation boards can be used to easily create bench prototypes of a power system. The ADM1186 micro-evaluation boards provide all the minimum components necessary to sequence and monitor four external dc-to-dc power modules or LDOs.

Each micro-evaluation board provides precision resistors for scaling to monitor 3.3 V, 2.5 V, 1.8 V, and 1.5 V rails, and capacitors to set the sequencing and blanking delays. A pull-up resistor is also provided on each open-drain output to ensure correct operation.

A bank of switches is provided to enable the single-step operation of the state machine. These switches operate in the same ways as the Delay x control switches on the main evaluation boards. Turning on a switch grounds a time capacitor and holds the state machine in the given state if that capacitor is being used to control a time delay.

One of the switches on the EVAL-ADM1186-1MBZ is connected to the FAULT line and can be used to generate a fault condition, if required.

EVALUATION BOARD SCHEMATICS

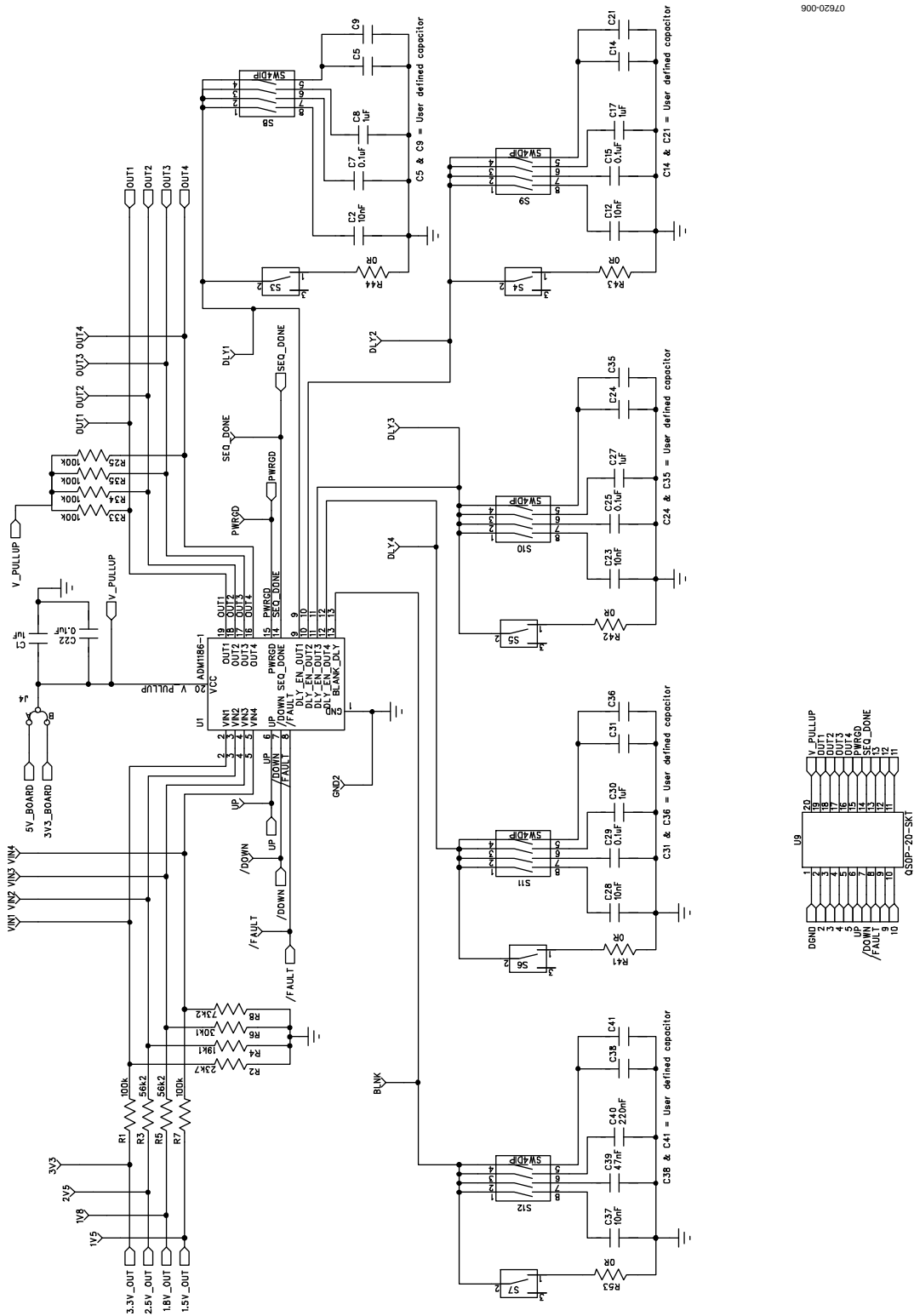

07620-006

Figure 6. EVAL-ADM1186-1EBZ Schematic Page 1

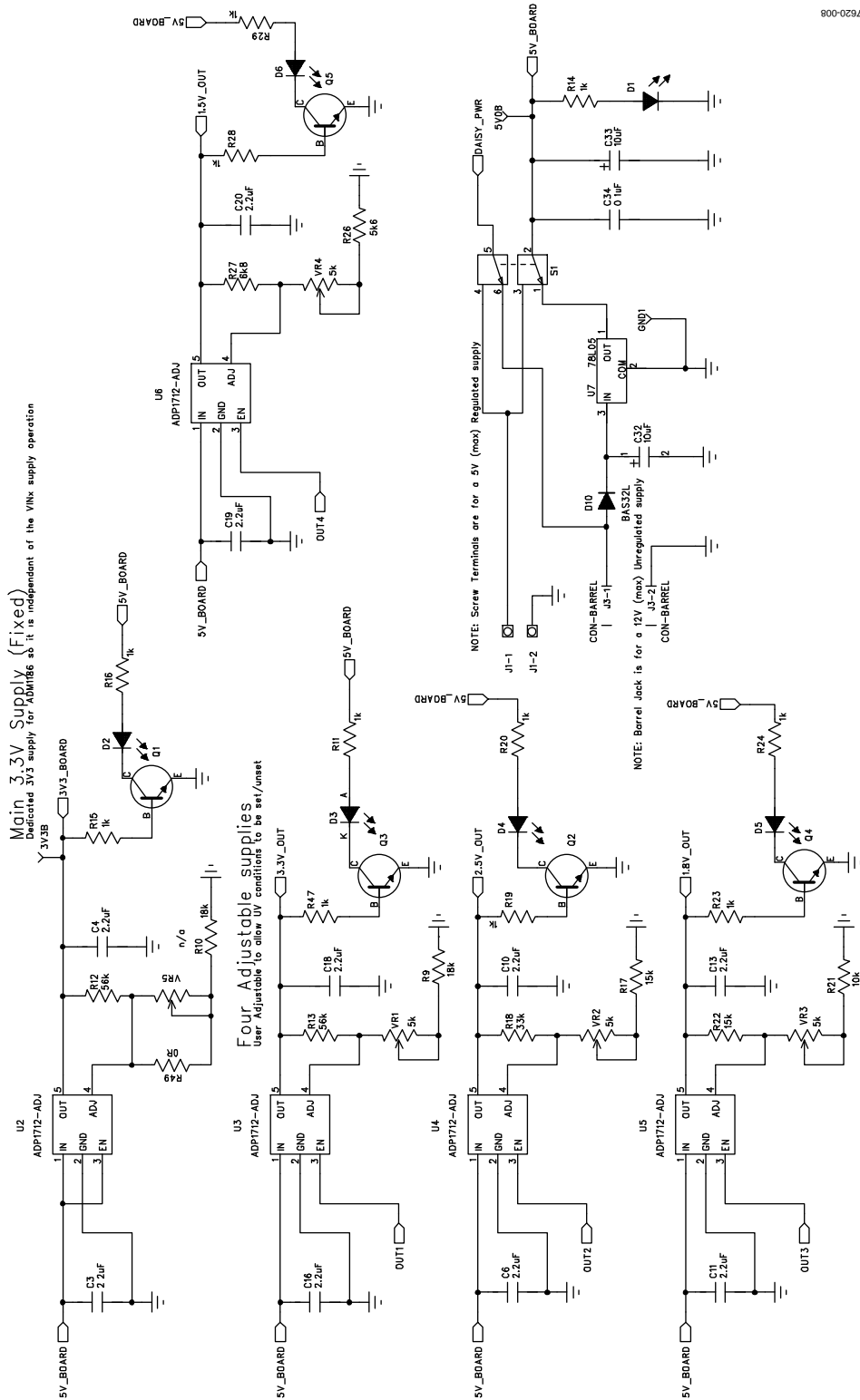
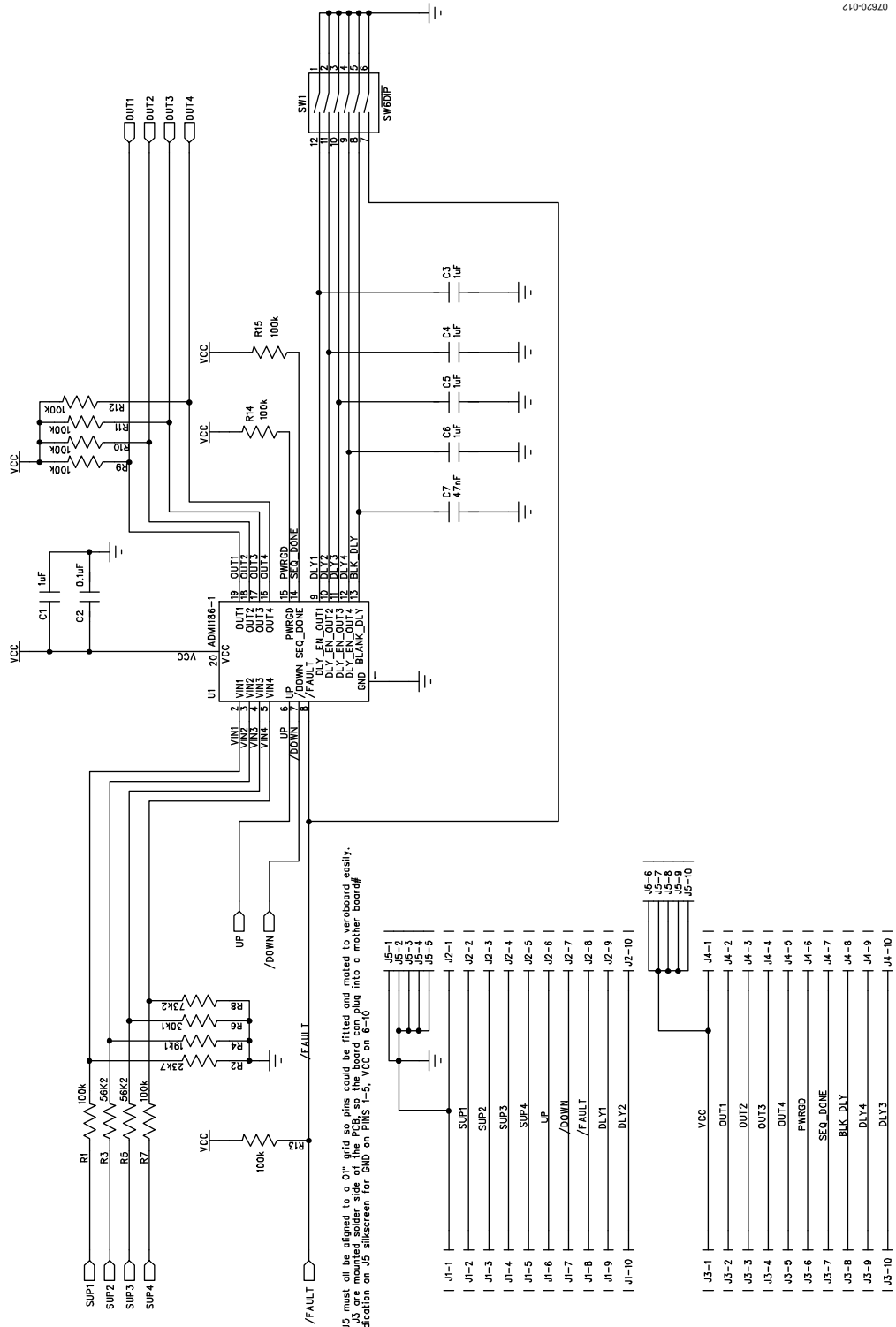

Figure 8. EVAL-ADM1186-1EBZ Schematic Page 3



J1 to J5 must all be aligned to a 0.01" grid, as this could be fitted and mated to a separate assembly. J1 and J5 are mounted solder side of the PCB, so the board can plug into a mother board. Add indication on J5 silkscreen for GND on PINS 1-5, VCC on 6-10

Figure 9. EVAL-ADM1186-1MBZ Schematic

EVAL-ADM1186

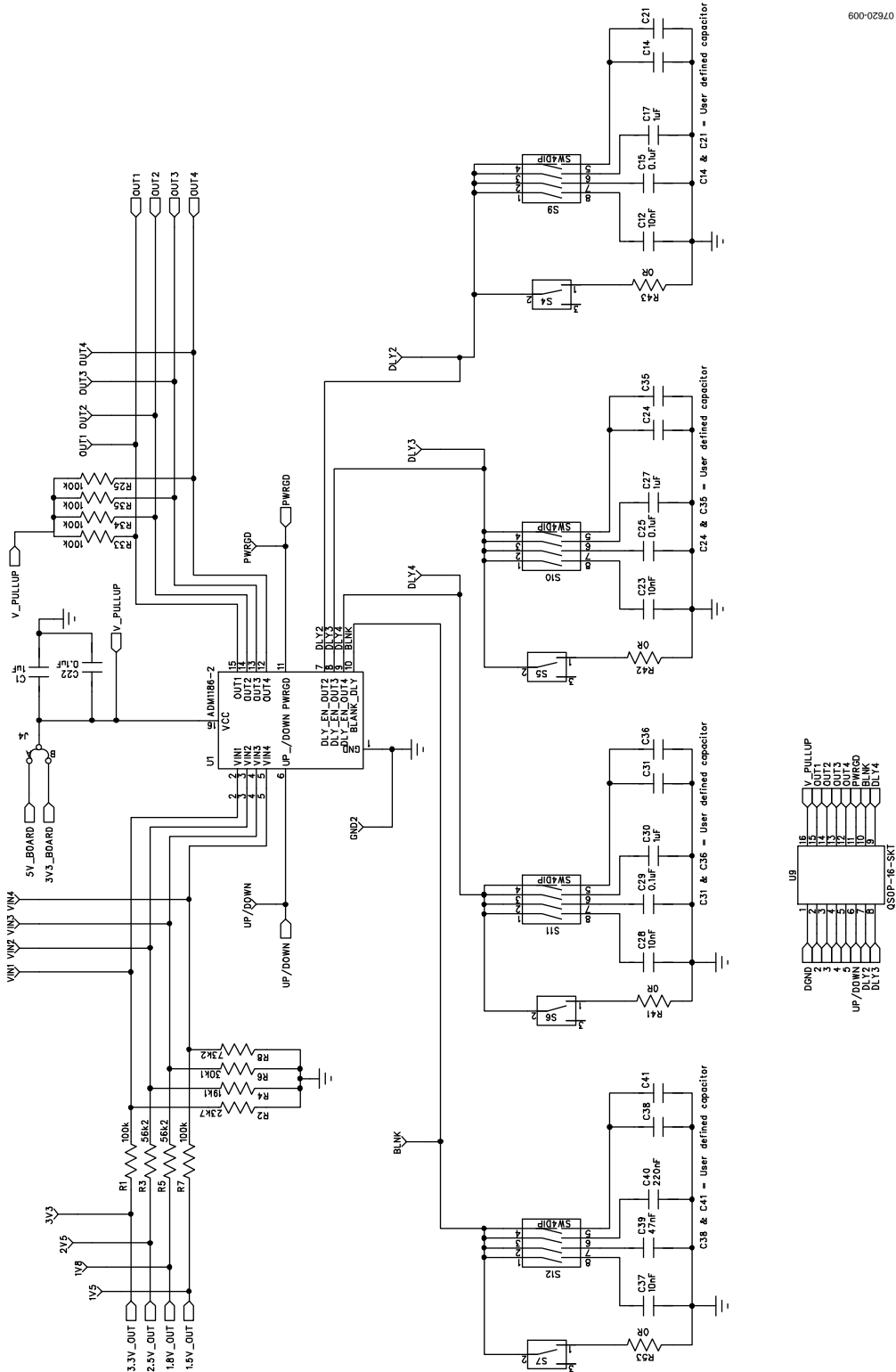

Figure 10. EVAL-ADM1186-2EBZ Schematic Page 1

07620-010

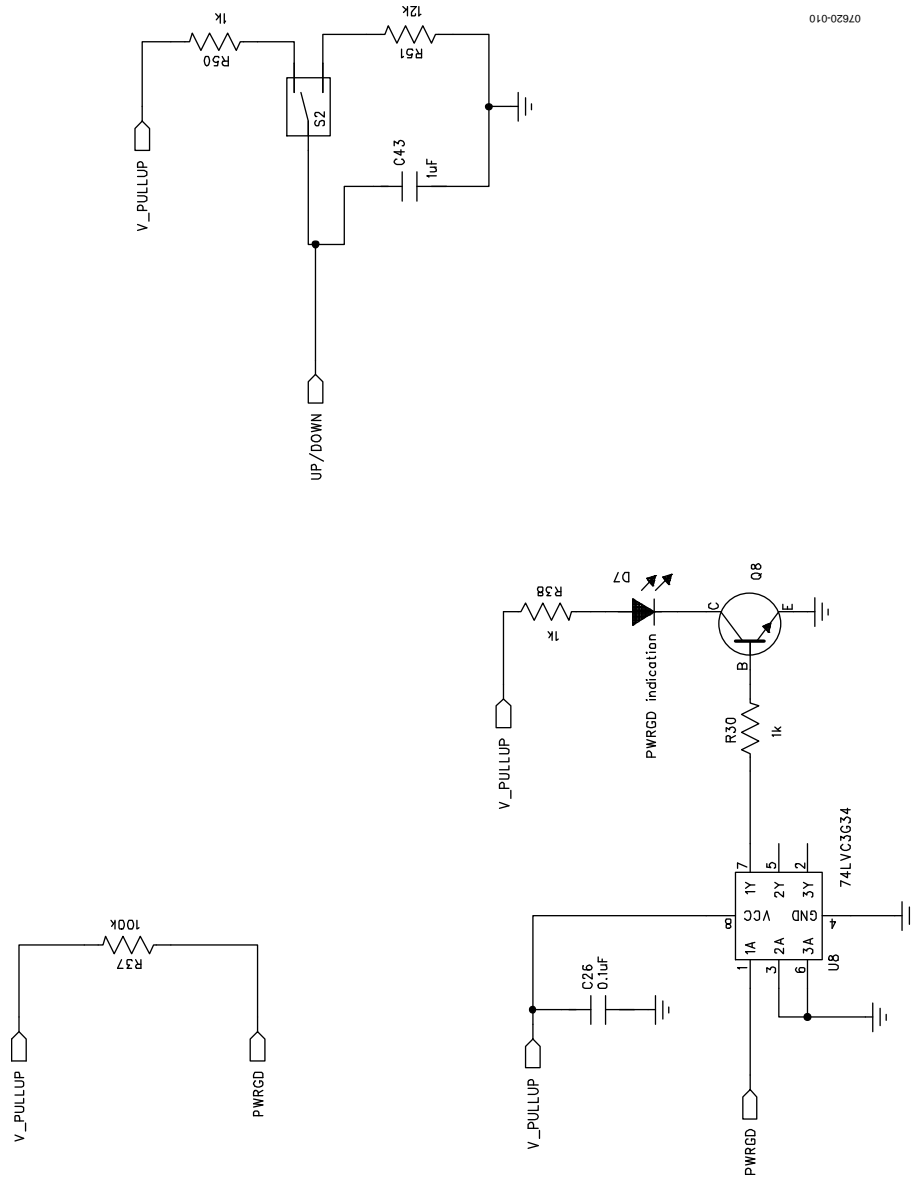

Figure 11. EVAL-ADM1186-2EBZ Schematic Page 2

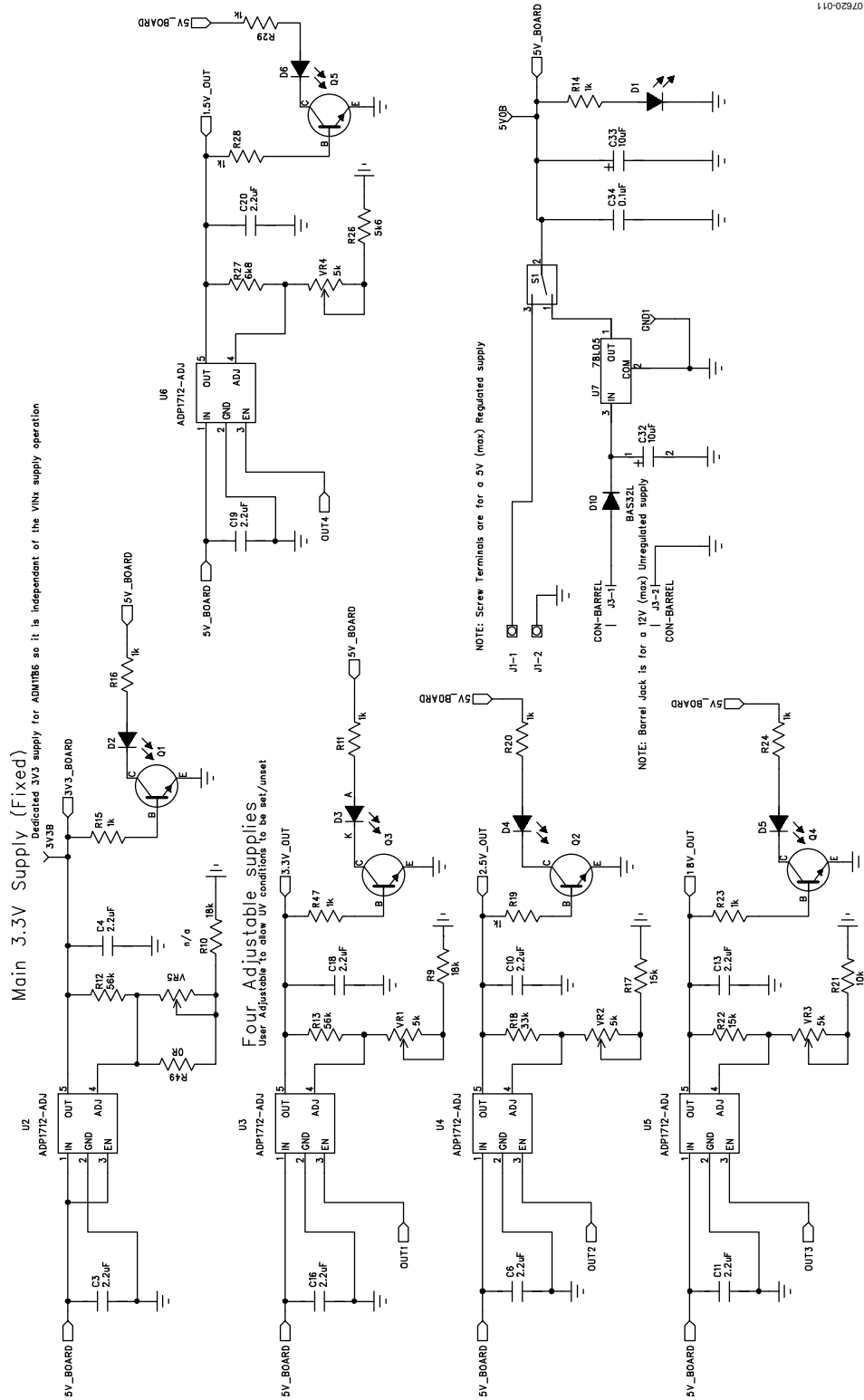

Figure 12. EVAL-ADM1186-2EBZ Schematic Page 3

EVAL-ADM1186

ORDERING INFORMATION

BILL OF MATERIALS

Table 8. Bill of Materials for the ADM1186-1EBZ

Qty	Reference Designator	Description	Supplier/Number	Part Number
25	/DOWN, /FAULT, 1V5, 1V8, 2V5, 3V3, 3V3B, 5V0B, BLNK, DLY1, DLY2, DLY3, DLY4, GND1, GND2, OUT1 to OUT4, PWRGD, SEQ_CNTRL_A, SEQ_CNTRL_B, SEQ_DONE, SEQ_DONE_NEXT, SEQ_DONE_PREV	Red testpoint	Vero 20-313137	FEC 8731144
5	UP, VIN1 to VIN4	Red top layer testpoint	Vero 20-313137	FEC 8731144
6	C1, C8, C17, C27, C30, C43	1 μ F, 10 V, \pm 10%, 0805 capacitor	AVX 0805ZC105KAT2A	FEC 1327700
5	C2, C12, C23, C28, C37	10 nF, \pm 10%, 0805 capacitor	Multicomp U0805R103KCT	FEC 9406352
10	C3, C4, C6, C10, C11, C13, C16, C18 to C20	2.2 μ F, 10 V, \pm 10%, X7R, 0805 capacitor	Phycomp 222224015667	FEC 9402152
5	C5, C14, C24, C31, C38	0805 capacitor, user defined		Option only, not fitted
7	C7, C15, C22, C25, C26, C29, C34	0.1 μ F, \pm 10%, 0805 capacitor	Kemet C0805F104K5RAC	FEC 1288272
5	C9, C21, C35, C36, C41	Pin socket	Harwin H3153F01	FEC 519935 (2 pins required per component)
2	C32, C33	10 μ F, 16 V, 10%, tantalum capacitor	EPCOS B45196H3106K209	FEC 9753893
1	C39	47 nF, 50 V, \pm 10% 0805 capacitor	Multicomp U0805R473KCT	FEC 9406379
1	C40	220 nF, 25 V, \pm 10% 0805 capacitor	AVX 08053C224KAZ1A	FEC 7569572
8	D1 to D8	Green 0805 chip LED	Kingsbright KP-2012SGC	FEC 1318243
1	D9	Red 0805 chip LED	Kingsbright KP-2012SRC-PRV	FEC 1318244
1	D10	High speed switching diode, SOD-80C	NXP BAS32L	FEC 1097173
1	J1	2-pin top-layer terminal block (5 mm pitch),	Lumberg KRM 02	FEC 1177875
1	J2	8-way top-layer right angle SIL header, (only 8 of the 36 way needed per board)	Fisher Elektronik SL 3.25.36G	FEC 9729100
1	J3	2.1 mm dc top-layer barrel power connector	Cliff Electronic Components DC10A	FEC 224959
3	J4 to J6	3-pin SIL header and shorting link	Harwin M20-9990345 and M7567-05	FEC 1022248 and 150410
3	J7 to J9	2-pin (0.1" pitch) header and shorting shunt	Harwin M20-9990246 and M7566-05	FEC 1022247 and 150411
1	J10	2-pin (0.1" pitch) header and shorting shunt	Harwin M20-9990246 and M7566-05	FEC 1022247 and 150411
1	J11	16-pin top-layer header; 100 mil centers, DIP16	Harwin M20-7890846	FEC 7992092
7	Q1 to Q5, Q8, Q10	BC850C, SOT-23, general-purpose NPN SMD transistor	NXP BC850C	FEC 1081241
1	Q9	BC860C, SOT-23, general-purpose PNP silicon transistor	NXP BC860C	FEC 1081249
1	R1	100 k Ω , \pm 0.1%, 0805 resistor	Welwyn PCF0805R 100KBI.T1	FEC 1160261
1	R2	23.7 k Ω , \pm 0.1%, 0805 resistor	Welwyn PCF0805R 23K7BI.T1	FEC 1160225
2	R3, R5	56.2 k Ω , \pm 0.1%, 0805 resistor	Welwyn PCF0805R 56K2BI.T1	FEC 1160251

Qty	Reference Designator	Description	Supplier/Number	Part Number
1	R4	19.1 kΩ, ±0.1%, 0805 resistor	Welwyn PCF0805R-19K1BT1	FEC 1353228
1	R6	30.1 kΩ, ±0.1%, 0805 resistor	Welwyn PCF0805R-30K1BI.T1	FEC 1160234
1	R7	100 kΩ, ±0.1%, 0805 resistor	Welwyn PCF0805R-100KBI.T1	FEC 1160261
1	R8	73.2 kΩ, ±0.1%, 0805 resistor	Welwyn PCF0805R-73K2BT1	FEC 1353300
1	R9	18 kΩ, ±1%, 0805 resistor	Phycomp 232273461803	FEC 9237780
1	R10	18 kΩ, ±1%, 0805 resistor	Phycomp 232273461803	FEC 9237780
18	R11, R14 to R16, R19, R20, R23, R24, R28 to R30, R32, R36, R38, R39, R47, R48, R50	1 kΩ, 0.1 W, ±2%, 0805 resistor	Welwyn WCR 0805 1K G	FEC 1099800
2	R12, R13	56 kΩ, ±1%, 0805 resistor	Phycomp 232273465603	FEC 9237844
1	R17	15 kΩ, ±1%, 0805 resistor	Phycomp 232273461503	FEC 9237771
1	R18	33 kΩ, ±1%, 0805 resistor	Phycomp 232273463303	FEC 9237810
1	R21	10 kΩ, ±1%, 0805 resistor	Phycomp 232273461003	FEC 9237755
1	R22	15 kΩ, ±1%, 0805 resistor	Phycomp 232273461503	FEC 9237771
7	R25, R31, R33, R34, R35, R37, R40	100 kΩ, 0.1 W, ±2%, 0805 resistor	Welwyn WCR 0805 100K G	FEC 1099816
1	R26	5.6 kΩ, ±1%, 0805 resistor	Phycomp 232273465602	FEC 9237712
1	R27	6.8 kΩ, ±1%, 0805 resistor	Phycomp 232273466802	FEC 9237739
7	R41 to R45, R49, R53	0 Ω, 0805 resistor	Welwyn WCR 0805 0R0 G	FEC 1099786
1	R51	12 kΩ, 0.1 W, ±2%, 0805 resistor	Welwyn WCR 0805 12K G	FEC 1100321
1	S1	Slide switch (extended top actuator)	Alps STSSS9221	FEC 1123878
6	S2 to S7	Slide switch	Alps STSSS9121	FEC 1123875
5	S8 to S12	4-way switch	Omron Electronic Components A6S-4101	FEC 9901868
1	S13	Push button switch	Omron Electronic Components B3S-1000	FEC 177807
1	U1	ADM1186-1, 20-lead QSOP	Analog Devices, Inc. ADM1186-1ARQZ	ADM1186-1ARQZ
5	U2 to U6	ADP1712-ADJ, 5-lead SOT-23, adjustable LDO	Analog Devices, Inc. ADP1712AUJZ-R7	ADP1712AUJZ-R7
1	U7	3-terminal, 0.1 A, 5 V positive voltage regulator, 78L05, TO-92	ON Semiconductor MC78L05ACPG	FEC 9666125
1	U9	20-pin QSOP socket; fitted only if U1 is not present	Enplas OTS-20(28)-0.635-02-00	OTS-20(28)-0.635-02-00
1	U8	74LVC3G34, VSSOP8	Texas Instruments SN74LVC3G34DCUR	FEC 1287565
4	VR1 to VR4	5 kΩ trimmer potentiometer	Vishay Spectrol 63M-T607-502	FEC 9608222
1	VR5	Trimmer potentiometer	Vishay Spectrol	Option only, not fitted

EVAL-ADM1186

Table 9. Bill Of Materials for the EVAL-ADM1186-1MBZ

Qty	Reference Designator	Description	Supplier/Number	Part Number
5	C1, C3 to C6	1 μ F, 10 V, \pm 10%, 0805 capacitor	AVX 0805ZC105KAT2A	FEC 1327700
1	C2	0.1 μ F, \pm 10%, 0805 capacitor	Kemet C0805F104K5RAC	FEC 1288272
1	C7	47 nF, 50 V, \pm 10%, 0805 capacitor	Multicomp U0805R473KCT	FEC 9406379
2	J1, J3	8-pin header, 100 mil centers	Harwin D01-9922046	FEC 1022217
3	J2, J4, J5	8-pin header, 100 mil centers	No component fitted	N/A
2	R1, R7	100 k Ω , \pm 0.1%, 0805 resistor	Welwyn PCF0805R 100KBI.T1	FEC 1160261
1	R2	23.7 k Ω , \pm 0.1%, 0805 resistor	Welwyn PCF0805R 23K7BI.T1	FEC 1160225
2	R3, R5	56.2 k Ω , \pm 0.1%, 0805 resistor	Welwyn PCF0805R 56K2BI.T1	FEC 1160251
1	R4	19.1 k Ω , \pm 0.1%, 0805 resistor	Welwyn PCF0805R-19K1BT1	FEC 1353228
1	R6	30.1 k Ω , \pm 0.1%, 0805 resistor	Welwyn PCF0805R 30K1BI.T1	FEC 1160234
1	R8	73.2 k Ω , \pm 0.1%, 0805 resistor	Welwyn PCF0805R-73K2BT1	FEC 1353300
7	R9 to R12, R13 to R15	100 k Ω , 0.1 W, \pm 2%, 0805 resistor	Welwyn WCR 0805 100K G	FEC 1099816
1	SW1	6-way DIL switch	Multicomp MCDM(R)-06-T	FEC 9472045
1	U1	ADM1186-1, 20-lead QSOP, 4-channel up/down sequencer and monitor	Analog Devices, Inc. ADM1186-1ARQZ	ADM1186-1ARQZ

Table 10. Bill of Materials for the ADM1186-2EBZ

Qty	Reference Designator	Description	Supplier/ Number	Part Number
22	1V5, 1V8, 2V5, 3V3, 3V3B, 5V0B, BLNK, DLY2 to DLY4, GND1, GND2, OUT1 to OUT4, PWRGD, UP/DOWN, VIN1 to VIN4	Red testpoint	Vero 20-313137	FEC 8731144
5	C1, C17, C27, C30, C43	1 μ F, \pm 10%, 10 V, 0805 capacitor	AVX 0805ZC105KAT2A	FEC 1327700
10	C3, C4, C6, C10, C11, C13, C16, C18 to C20	2.2 μ F, \pm 10%, 10 V, X7R, 0805 capacitor	Phycomp 222224015667	FEC 9402152
1	C12	10 nF, \pm 10%, 0805 capacitor	Multicomp U0805R103KCT	FEC 9406352
4	C14, C24, C31, C38	User defined, 0805 capacitor		Option only, not fitted
2	C15, C34	0.1 μ F, \pm 10%, 0805 capacitor	Kemet C0805F104K5RAC	FEC 1288272
4	C21, C35, C36, C41	Single pin socket	Harwin H3153F01	FEC 519935 (2 pins required per component)
4	C22, C25, C26, C29	0.1 μ F, \pm 10%, 0805 capacitor	Kemet C0805F104K5RAC	FEC 1288272
3	C23, C28, C37	10 nF, \pm 10%, 0805 capacitor	Multicomp U0805R103KCT	FEC 9406352
2	C32, C33	10 μ F, 10%, RTAJ_B, 16 V tantalum capacitor	Kemet B45196H3106K209	FEC 9753893
1	C39	47 nF, \pm 10%, 50 V, 0805 capacitor	Multicomp U0805R473KCT	FEC 9406379
1	C40	220 nF, \pm 10%, 25 V, 0805 capacitor	AVX 08053C224KAZ1A	FEC 7569572
7	D1 to D7	Green 0805 chip LED	Kingsbright KP-2012SGC	FEC 1318243
1	D10	High speed switching diode, SOD-80C	NXP BAS32L	FEC 1097173
1	J1	2-pin terminal block (5 mm pitch)	Lumberg KRM 02	FEC 1177875
1	J3	2.1 mm dc barrel power connector	Cliff Electronic Components DC10A	FEC 224-959
1	J4	3-pin SIL header and shorting link	Harwin M20-9990345 and M7567-05	FEC 1022248 and 150410
6	Q1 to Q5, Q8	BC850B, SOT-23, general-purpose NPN transistor	NXP BC850C	FEC 1081241
1	R1	100 k Ω , \pm 0.1%, 0805 resistor	Welwyn PCF0805R 100KBI.T1	FEC 1160261
1	R2	23.7 k Ω , \pm 0.1%, 0805 resistor	Welwyn PCF0805R 23K7BI.T1	FEC 1160225
2	R3, R5	56.2 k Ω , \pm 0.1%, 0805 resistor	Welwyn PCF0805R 56K2BI.T1	FEC 1160251
1	R4	19.1 k Ω , \pm 0.1%, 0805 resistor	Welwyn PCF0805R-19K1BT1	FEC 1353228
1	R6	30.1 k Ω , \pm 0.1%, 0805 resistor	Welwyn PCF0805R 30K1BI.T1	FEC 1160234
1	R7	100 k Ω , \pm 0.1%, 0805 resistor	Welwyn PCF0805R 100KBI.T1	FEC 1160261
1	R8	73.2 k Ω , \pm 0.1%, 0805 resistor	Welwyn PCF0805R-73K2BT1	FEC 1353300
2	R9, R10	18 k Ω , \pm 1%, 0805 resistor	Phycomp 232273461803	FEC 9237780
14	R11, R14 to R16, R19, R20, R23, R24, R28, R29, R30, R38, R47, R50	1 k Ω , \pm 2%, 0.1 W, 0805 resistor	Welwyn WCR 0805 1K G	FEC 1099800
2	R12, R13	56 k Ω , \pm 1%, 0805 resistor	Phycomp 232273465603	FEC 9237844
2	R17, R22	15 k Ω , \pm 1%, 0805 resistor	Phycomp 232273461503	FEC 9237771
1	R18	33 k Ω , \pm 1%, 0805 resistor	Phycomp 232273463303	FEC 9237810
1	R21	10 k Ω , \pm 1%, 0805 resistor	Phycomp 232273461003	FEC 9237755
5	R25, R33, R34, R35, R37	100 k Ω , \pm 2%, 0805 resistor	Welwyn WCR 0805 100K G	FEC 1099816
1	R26	5.6 k Ω , \pm 1%, 0805 resistor	Phycomp 232273465602	FEC 9237712

EVAL-ADM1186

Qty	Reference Designator	Description	Supplier/Number	Part Number
1	R27	6.8 k Ω , \pm 1%, 0805 resistor	Phycomp 232273466802	FEC 9237739
5	R41 to R43, R49, R53	0 Ω , 0805 resistor	Welwyn WCR 0805 0R0 G	FEC 1099786
1	R51	12 k Ω , \pm 2%, 0.1 W, 0805, resistor	Welwyn WCR 0805 12K G	FEC 1100321
6	S1, S2, S4 to S7	SPDT slide switch	Alps STSSS9121	FEC 1123875
4	S9 to S12	4-way switch	Omron Electronic Components A6S-4101	FEC 9901868
4	VR1 to VR4	Trimmer potentiometer	Vishay Spectrol 63M-T607-502	FEC 9608222
1	VR5	Trimmer potentiometer	Vishay Spectrol	Option only, not fitted
1	U1	ADM1186-2, QSOP-16, top layer	Analog Devices, Inc. ADM1186-2ARQZ	ADM1186-2ARQZ
5	U2 to U6	ADP1712-ADJ, SOT23-5, adjustable LDO	Analog Devices, Inc. ADP1712AUJZ-R7	ADP1712AUJZ-R7
1	U7	78L05, TO-92A, 3-terminal 0.1 A, 5 V positive voltage regulator	ON Semiconductor MC78L05ACPG	FEC 9666125
1	U8	74LVC3G34, VSSOP8, , top layer	Texas Instruments SN74LVC3G34DCUR	FEC 1287565
1	U9	16-pin QSOP socket; fitted only if U1 not present	Enplas OTS-16(28)-0.635-02-00	OTS-16(28)-0.635-02-00

Table 11. Analog Bill Of Materials for the EVAL-ADM1186-2MBZ

Qty	Reference Designator	Description	Supplier/Manufacturer	Part Number
4	C1, C4 to C6	1 μ F, 10 V, \pm 10%, 0805 capacitor	AVX 0805ZC105KAT2A	FEC 1327700
1	C2	0.1 μ F, \pm 10%, 0805 capacitor	Kemet C0805F104K5RAC	FEC 1288272
1	C7	47 nF, 50 V, \pm 10%, 0805 capacitor	Multicomp U0805R473KCT	FEC 9406379
2	J1, J3	8-pin header, 100 mil centers	Harwin D01-9922046	FEC 1022217
3	J2, J4, J5	8-pin header, 100 mil centers	No component fitted	N/A
2	R1, R7	100 k Ω , \pm 0.1%, 0805 capacitor	Welwyn PCF0805R 100KBI.T1	FEC 1160261
1	R2	23.7 k Ω , \pm 0.1%, 0805 capacitor	Welwyn PCF0805R 23K7BI.T1	FEC 1160225
2	R3, R5	56.2 k Ω , \pm 0.1%, 0805 capacitor	Welwyn PCF0805R 56K2BI.T1	FEC 1160251
1	R4	19.1 k Ω , \pm 0.1%, 0805 capacitor	Welwyn PCF0805R-19K1BT1	FEC 1353228
1	R6	30.1 k Ω , \pm 0.1%, 0805 capacitor	Welwyn PCF0805R 30K1BI.T1	FEC 1160234
1	R8	73.2 k Ω , \pm 0.1%, 0805 capacitor	Welwyn PCF0805R-73K2BT1	FEC 1353300
5	R9 to R12, R14	100 k Ω , \pm 2%, 0.1 W, 0805 capacitor	Welwyn WCR 0805 100K G	FEC 1099816
1	SW1	4-way switch	Omron Electronic Components A6S-4101	FEC 9901868
1	U1	ADM1186-2, 16-lead QSOP, 4-channel up/down sequencer and monitor	Analog Devices, Inc.	ADM1186-2ARQZ

ORDERING GUIDE

Model	Description
EVAL-ADM1186-1EBZ ¹	Evaluation Board for ADM1186-1
EVAL-ADM1186-1MBZ ¹	Micro-Evaluation Board for ADM1186-1
EVAL-ADM1186-2EBZ ¹	Evaluation Board for ADM1186-2
EVAL-ADM1186-2MBZ ¹	Micro-Evaluation Board for ADM1186-2

¹ Z = RoHS Compliant Part.

ESD CAUTION



ESD (electrostatic discharge) sensitive device. Charged devices and circuit boards can discharge without detection. Although this product features patented or proprietary protection circuitry, damage may occur on devices subjected to high energy ESD. Therefore, proper ESD precautions should be taken to avoid performance degradation or loss of functionality.