

FEATURES
High performance
Temperature accuracy

±0.20°C from -10°C to +85°C at 3.0 V to 3.3 V

±0.25°C from -20°C to +105°C from 3.0 V to 3.6 V

16-bit temperature resolution: 0.0078°C
Ultralow temperature drift: 0.0073°C
NIST traceable or equivalent
Fast first temperature conversion on power-up of 6 ms
Easy implementation
No temperature calibration/correction required by user
No linearity correction required
Low power
Power-saving 1 sample per second (SPS) mode
700 μW typical at 3.3 V in normal mode
7 μW typical at 3.3 V in shutdown mode
Wide operating ranges
Temperature range: -40°C to +150°C
Voltage range: 2.7 V to 5.5 V
Programmable interrupts
Critical overtemperature interrupt
Overtemperature/undertemperature interrupt
I²C-compatible interface
16-lead, 4 mm × 4 mm LFCSP RoHS-compliant package
APPLICATIONS
RTD and thermistor replacement
Thermocouple cold junction compensation
Medical equipment
Industrial control and test
Food transportation and storage
Environmental monitoring and HVAC
Laser diode temperature control
GENERAL DESCRIPTION

The ADT7420 is a high accuracy digital temperature sensor offering breakthrough performance over a wide industrial range, housed in a 4 mm × 4 mm LFCSP package. It contains an internal band gap reference, a temperature sensor, and a 16-bit ADC to monitor and digitize the temperature to 0.0078°C resolution. The ADC resolution, by default, is set to 13 bits (0.0625°C). The ADC resolution is a user programmable mode that can be changed through the serial interface.

The ADT7420 is guaranteed to operate over supply voltages from 2.7 V to 5.5 V. Operating at 3.3 V, the average supply current is typically 210 μA. The ADT7420 has a shutdown mode that powers down the device and offers a shutdown current of typically 2.0 μA at 3.3 V. The ADT7420 is rated for operation over the -40°C to +150°C temperature range.

Pin A0 and Pin A1 are available for address selection, giving the ADT7420 four possible I²C addresses. The CT pin is an open-drain output that becomes active when the temperature exceeds a programmable critical temperature limit. The INT pin is also an open-drain output that becomes active when the temperature exceeds a programmable limit. The INT pin and CT pin can operate in comparator and interrupt event modes.

PRODUCT HIGHLIGHTS

1. Ease of use, no calibration or correction required by the user.
2. Low power consumption.
3. Excellent long-term stability and reliability.
4. High accuracy for industrial, instrumentation, and medical applications.
5. Packaged in a 16-lead, 4 mm × 4 mm LFCSP RoHS-compliant package.

FUNCTIONAL BLOCK DIAGRAM

Figure 1.

Rev. PrE

Information furnished by Analog Devices is believed to be accurate and reliable. However, no responsibility is assumed by Analog Devices for its use, nor for any infringements of patents or other rights of third parties that may result from its use. Specifications subject to change without notice. No license is granted by implication or otherwise under any patent or patent rights of Analog Devices. Trademarks and registered trademarks are the property of their respective owners.

TABLE OF CONTENTS

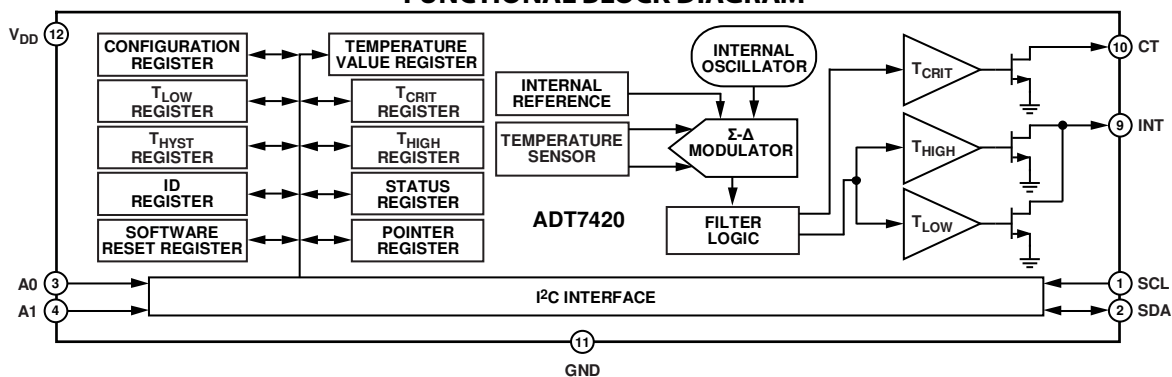
Features	1	Status Register	14
Applications.....	1	Configuration Register	14
General Description	1	T _{HIGH} Setpoint Registers.....	15
Product Highlights	1	T _{LOW} Setpoint Registers.....	15
Functional Block Diagram	1	T _{CRIT} Setpoint Registers.....	15
Specifications.....	3	T _{HYST} Setpoint Register.....	16
I ² C Timing Specifications.....	5	ID Register.....	16
Absolute Maximum Ratings.....	6	Serial Interface	17
ESD Caution.....	6	Serial Bus Address	17
Pin Configuration and Function Descriptions.....	7	Writing Data	18
Typical Performance Characteristics	8	Reading Data.....	19
Theory of Operation	10	Reset	20
Circuit Information.....	10	General Call	20
Converter Details.....	10	INT and CT Outputs.....	21
Normal Mode.....	10	Undertemperature and Overtemperature Detection	21
One-Shot Mode	10	Applications Information	23
1 SPS Mode.....	11	Thermal Response Time	23
Shutdown.....	11	Supply Decoupling	23
Fault Queue	11	Powering from a Switching Regulator.....	23
Temperature Data Format.....	12	Temperature Measurement.....	23
Temperature Conversion Formulas	12	Quick Guide to Measuring Temperature	23
Registers.....	13	Outline Dimensions	24
Address Pointer Register	13	Ordering Guide	24
Temperature Value Registers.....	13		

SPECIFICATIONS

$T_A = -40^{\circ}\text{C}$ to $+125^{\circ}\text{C}$, $V_{DD} = 2.7\text{ V}$ to 5.5 V , unless otherwise noted.

Table 1.

Parameter	Min	Typ	Max	Unit	Test Conditions/Comments
TEMPERATURE SENSOR AND ADC					
Accuracy ¹		0.0017	$\pm 0.20^2$	$^{\circ}\text{C}$	$T_A = -10^{\circ}\text{C}$ to $+85^{\circ}\text{C}$, $V_{DD} = 3.0\text{ V}$ to 3.3 V
			± 0.25	$^{\circ}\text{C}$	$T_A = -20^{\circ}\text{C}$ to $+105^{\circ}\text{C}$, $V_{DD} = 3.0\text{ V}$ to 3.6 V
			± 0.25	$^{\circ}\text{C}$	$T_A = -20^{\circ}\text{C}$ to $+85^{\circ}\text{C}$, $V_{DD} = 2.7\text{ V}$
			± 0.30	$^{\circ}\text{C}$	$T_A = -40^{\circ}\text{C}$ to $+105^{\circ}\text{C}$, $V_{DD} = 3.0\text{ V}$
			± 0.35	$^{\circ}\text{C}$	$T_A = -40^{\circ}\text{C}$ to $+105^{\circ}\text{C}$, $V_{DD} = 2.7\text{ V}$ to 3.3 V
			± 0.50	$^{\circ}\text{C}$	$T_A = -40^{\circ}\text{C}$ to $+125^{\circ}\text{C}$, $V_{DD} = 3.0\text{ V}$ to 3.6 V
			$\pm 0.50^3$	$^{\circ}\text{C}$	$T_A = -10^{\circ}\text{C}$ to $+105^{\circ}\text{C}$, $V_{DD} = 4.5\text{ V}$ to 5.5 V
			± 0.65	$^{\circ}\text{C}$	$T_A = -40^{\circ}\text{C}$ to $+125^{\circ}\text{C}$, $V_{DD} = 4.5\text{ V}$ to 5.5 V
		-0.85		$^{\circ}\text{C}$	$T_A = +150^{\circ}\text{C}$, $V_{DD} = 4.5\text{ V}$ to 5.5 V
		-1.0		$^{\circ}\text{C}$	$T_A = +150^{\circ}\text{C}$, $V_{DD} = 2.7\text{ V}$ to 3.6 V
ADC Resolution		13		Bits	Twos complement temperature value of the sign bit plus 12 ADC bits (power-up default resolution)
		16		Bits	Twos complement temperature value of the sign bit plus 15 ADC bits (Bit 7 = 1 in the configuration register)
Temperature Resolution					
13-Bit		0.0625		$^{\circ}\text{C}$	13-bit resolution (sign + 12-bit)
16-Bit		0.0078		$^{\circ}\text{C}$	16-bit resolution (sign + 15-bit)
Temperature Conversion Time		240		ms	Continuous conversion and one-shot conversion modes
Fast Temperature Conversion Time		6		ms	First conversion on power-up only
1 SPS Conversion Time		60		ms	Conversion time for 1 SPS mode
Temperature Hysteresis		± 0.002		$^{\circ}\text{C}$	Temperature cycle = 25°C to 125°C and back to 25°C
Repeatability ⁴		± 0.015		$^{\circ}\text{C}$	$T_A = 25^{\circ}\text{C}$
Drift ⁵		0.0073		$^{\circ}\text{C}$	500 hour stress test at $+150^{\circ}\text{C}$ with $V_{DD} = 5.0\text{ V}$
DC PSRR		0.1		$^{\circ}\text{C}/\text{V}$	$T_A = 25^{\circ}\text{C}$
DIGITAL OUTPUTS (CT, INT, SDA—OPEN DRAIN)					
High Output Leakage Current, I_{OH}		0.1	5	μA	CT and INT pins pulled up to 5.5 V
Output Low Voltage, V_{OL}			0.4	V	$I_{OL} = 3\text{ mA}$ at 5.5 V , $I_{OL} = 1\text{ mA}$ at 3.3 V
Output High Voltage, V_{OH}	$0.7 \times V_{DD}$			V	
Output Capacitance, C_{OUT}		2		pF	
DIGITAL INPUTS (SCL, SDA, A0, A1)					
Input Current			± 1	μA	$V_{IN} = 0\text{ V}$ to V_{DD}
Input Low Voltage, V_{IL}			$0.3 \times V_{DD}$	V	SCL and SDA only
			0.4	V	A0 and A1 only
Input High Voltage, V_{IH}	$0.7 \times V_{DD}$			V	SCL and SDA only
	2			V	A0 and A1 only
SCL, SDA Glitch Rejection		50		ns	Input filtering suppresses noise spikes of less than 50 ns
Pin Capacitance		2	10	pF	
POWER REQUIREMENTS					
Supply Voltage	2.7		5.5	V	
Supply Current					
At 3.3 V		210	265	μA	Peak current while converting, $I^2\text{C}$ interface inactive
At 5.5 V		250	300	μA	Peak current while converting, $I^2\text{C}$ interface inactive

Parameter	Min	Typ	Max	Unit	Test Conditions/Comments
1 SPS Current					
At 3.3 V		46		μA	$V_{DD} = 3.3\text{ V}$, 1 SPS mode, $T_A = 25^\circ\text{C}$
At 5.5 V		65		μA	$V_{DD} = 5.5\text{ V}$, 1 SPS mode, $T_A = 25^\circ\text{C}$
Shutdown Current					
At 3.3 V		2.0	15	μA	Supply current in shutdown mode
At 5.5 V		5.2	25	μA	Supply current in shutdown mode
Power Dissipation Normal Mode		700		μW	$V_{DD} = 3.3\text{ V}$, normal mode at 25°C
Power Dissipation 1 SPS		150		μW	Power dissipated for $V_{DD} = 3.3\text{ V}$, $T_A = 25^\circ\text{C}$

¹ Accuracy specification includes repeatability.

² The equivalent 3σ limits are $\pm 0.15^\circ\text{C}$. This 3σ specification is provided to enable comparison with other vendors who use these limits.

³ For higher accuracy at 5 V operation, contact Analog Devices, Inc.

⁴ Based on a floating average of 10 readings.

⁵ Drift includes solder heat resistance and life time test performed as per JEDEC Standard JESD22-A108.

I²C TIMING SPECIFICATIONS

T_A = -40°C to +150°C, V_{DD} = 2.7 V to 5.5 V, unless otherwise noted. All input signals are specified with rise time (t_R) = fall time (t_F) = 5 ns (10% to 90% of V_{DD}) and timed from a voltage level of 1.6 V.

Table 2.

Parameter	Min	Typ	Max	Unit	Test Conditions/Comments
SERIAL INTERFACE¹					
SCL Frequency	0		400	kHz	See Figure 2
SCL High Pulse Width, t _{HIGH}	0.6			μs	
SCL Low Pulse Width, t _{LOW}	1.3			μs	
SCL, SDA Rise Time, t _R			0.3	μs	
SCL, SDA Fall Time, t _F			0.3	μs	
Hold Time (Start Condition), t _{HD:STA}	0.6			μs	After this period, the first clock is generated
Setup Time (Start Condition), t _{SU:STA}	0.6			μs	Relevant for repeated start condition
Data Setup Time, t _{SU:DAT}	0.02			μs	
Setup Time (Stop Condition), t _{SU:STO}	0.6			μs	
Data Hold Time, t _{HD:DAT} (Master)	0.03			μs	
Bus-Free Time (Between Stop and Start Condition), t _{BUF}	1.3			μs	
Capacitive Load for Each Bus Line, C _B			400	pF	

¹ Sample tested during initial release to ensure compliance.

Timing Diagram

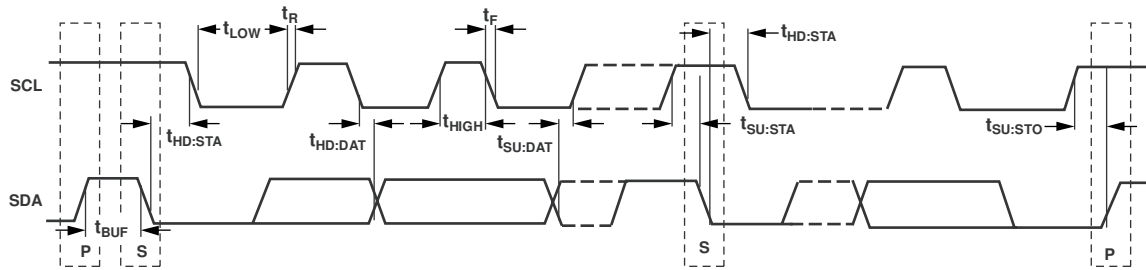

Figure 2. Serial Interface Timing Diagram

09013-002

ABSOLUTE MAXIMUM RATINGS

Table 3.

Parameter	Rating
V _{DD} to GND	−0.3 V to +7 V
SDA Voltage to GND	−0.3 V to V _{DD} + 0.3 V
SCL Output Voltage to GND	−0.3 V to V _{DD} + 0.3 V
A0 Input Voltage to GND	−0.3 V to V _{DD} + 0.3 V
A1 Input Voltage to GND	−0.3 V to V _{DD} + 0.3 V
CT and INT Output Voltage to GND	−0.3 V to V _{DD} + 0.3 V
ESD Rating (Human Body Model)	2.0 kV
Operating Temperature Range ¹	−40°C to +150°C
Storage Temperature Range	−65°C to +160°C
Maximum Junction Temperature, T _{JMAX}	150°C
16-Lead LFCSP (CP-16-17)	
Power Dissipation ²	$W_{MAX} = (T_{JMAX} - T_A^3)/\theta_{JA}$
Thermal Impedance ⁴	
θ_{JA} , Junction-to-Ambient (Still Air)	37°C/W
θ_{JC} , Junction-to-Case	33°C/W
IR Reflow Soldering	220°C
Peak Temperature (RoHS-Compliant Package)	260°C (+0°C/−5°C)
Time at Peak Temperature	20 sec to 40 sec
Ramp-Up Rate	3°C/sec maximum
Ramp-Down Rate	−6°C/sec maximum
Time from 25°C to Peak Temperature	8 minutes maximum

¹ Sustained operation above 125°C results in a shorter product lifetime. For more information, contact Analog Devices.

² Values relate to package being used on a standard 2-layer PCB. This gives a worst-case θ_{JA} and θ_{JC} .

³ T_A = ambient temperature.

⁴ Junction-to-case resistance is applicable to components featuring a preferential flow direction, for example, components mounted on a heat sink. Junction-to-ambient is more useful for air-cooled, PCB-mounted components.

Stresses above those listed under Absolute Maximum Ratings may cause permanent damage to the device. This is a stress rating only; functional operation of the device at these or any other conditions above those indicated in the operational section of this specification is not implied. Exposure to absolute maximum rating conditions for extended periods may affect device reliability.

ESD CAUTION



ESD (electrostatic discharge) sensitive device. Charged devices and circuit boards can discharge without detection. Although this product features patented or proprietary protection circuitry, damage may occur on devices subjected to high energy ESD. Therefore, proper ESD precautions should be taken to avoid performance degradation or loss of functionality.

PIN CONFIGURATION AND FUNCTION DESCRIPTIONS

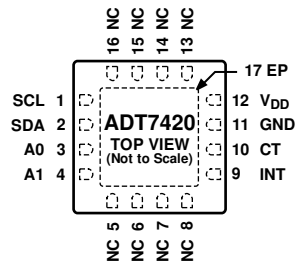

- NOTES
1. NC = NO CONNECT. THE NC PIN IS NOT BONDED TO THE DIE INTERNALLY.
 2. TO ENSURE CORRECT OPERATION, THE EXPOSED PAD SHOULD EITHER BE LEFT FLOATING OR CONNECTED TO GROUND.
- 09013-004

Figure 3. Pin Configuration

Table 4. Pin Function Descriptions

Pin No.	Mnemonic	Description
1	SCL	I ² C Serial Clock Input. The serial clock is used to clock in and clock out data to and from any register of the ADT7420. Open-drain configuration. A pull-up resistor is required, typically 10 kΩ.
2	SDA	I ² C Serial Data Input/Output. Serial data to and from the part is provided on this pin. Open-drain configuration. A pull-up resistor is required, typically 10 kΩ.
3	A0	I ² C Serial Bus Address Selection Pin. Logic input. Connect to GND or V _{DD} to set an I ² C address.
4	A1	I ² C Serial Bus Address Selection Pin. Logic input. Connect to GND or V _{DD} to set an I ² C address.
5	NC	No Connect. The NC pin is not bonded to the die internally.
6	NC	No Connect. The NC pin is not bonded to the die internally.
7	NC	No Connect. The NC pin is not bonded to the die internally.
8	NC	No Connect. The NC pin is not bonded to the die internally.
9	INT	Overtemperature and Undertemperature Indicator. Logic output. Power-up default setting is as an active low comparator interrupt. Open-drain configuration. A pull-up resistor is required, typically 10 kΩ.
10	CT	Critical Overtemperature Indicator. Logic output. Power-up default polarity is active low. Open-drain configuration. A pull-up resistor is required, typically 10 kΩ.
11	GND	Analog and Digital Ground.
12	V _{DD}	Positive Supply Voltage (2.7 V to 5.5 V). The supply should be decoupled with a 0.1 μF ceramic capacitor to ground.
13	NC	No Connect. The NC pin is not bonded to the die internally.
14	NC	No Connect. The NC pin is not bonded to the die internally.
15	NC	No Connect. The NC pin is not bonded to the die internally.
16	NC	No Connect. The NC pin is not bonded to the die internally.
17	EP	Exposed Pad. To ensure correct operation, the exposed pad should either be left floating or connected to ground.

TYPICAL PERFORMANCE CHARACTERISTICS

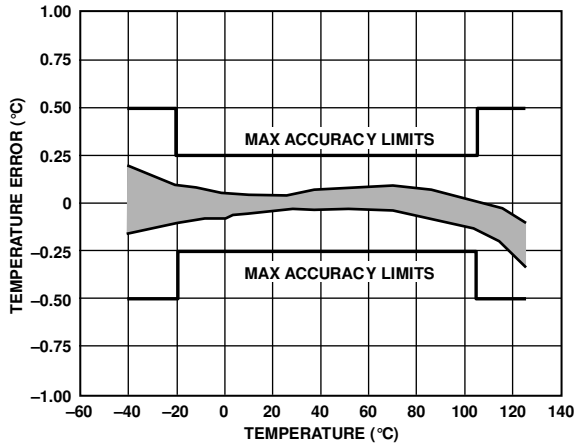

Figure 4. Temperature Accuracy at 3 V

09013-027

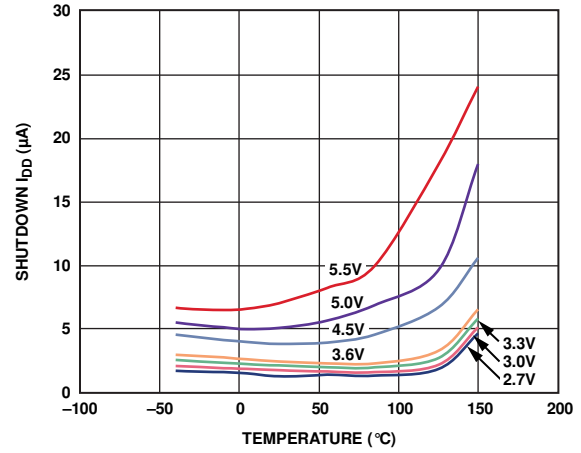

Figure 7. Shutdown Current vs. Temperature

09013-032

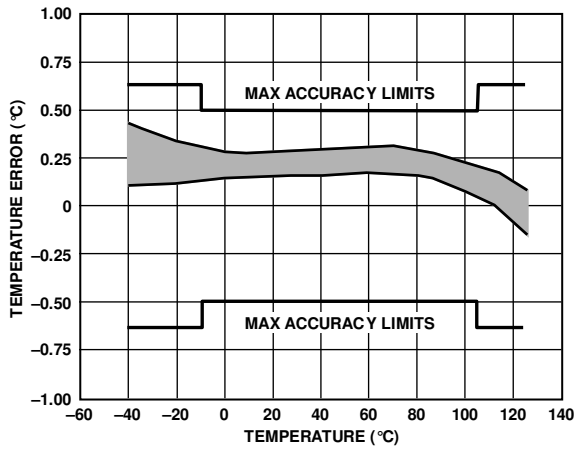

Figure 5. Temperature Accuracy at 5 V

09013-028

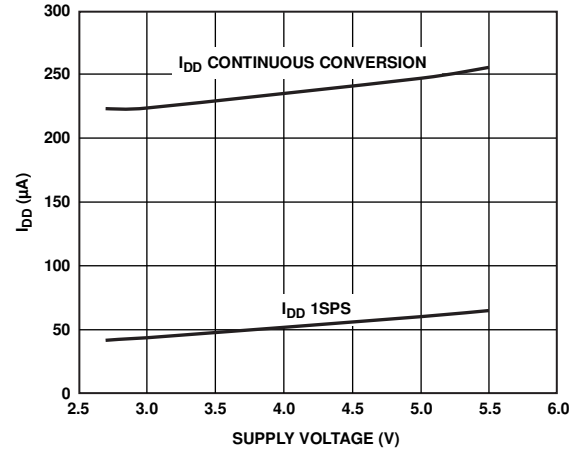

Figure 8. Average Operating Supply Current vs. Supply Voltage

09013-029

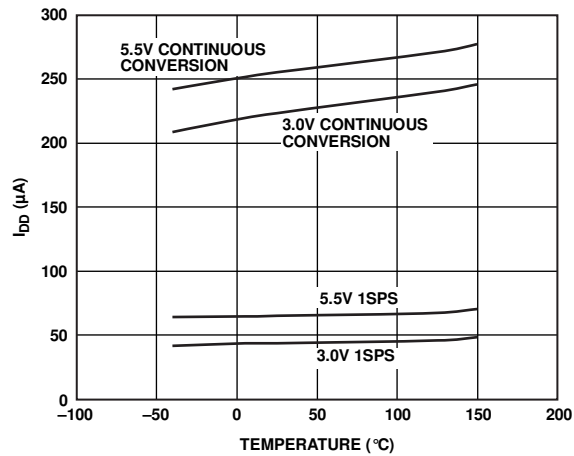

Figure 6. Operating Supply Current vs. Temperature

09013-028

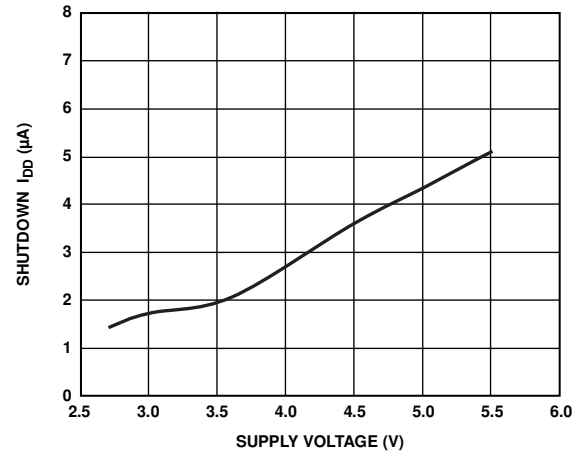

Figure 9. Shutdown Current vs. Supply Voltage

09013-210

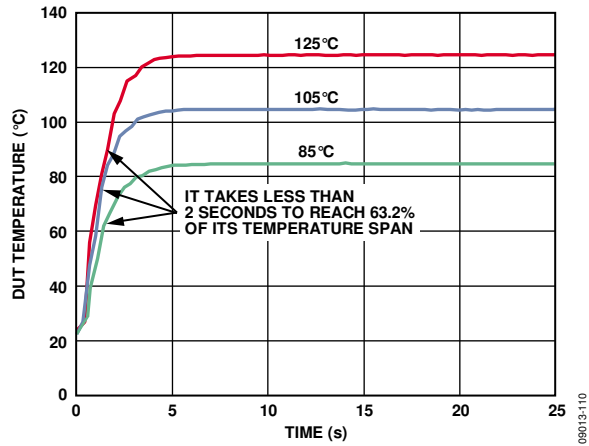

Figure 10. Thermal Response Time

THEORY OF OPERATION

CIRCUIT INFORMATION

The ADT7420 is a high accuracy digital temperature sensor that uses a 16-bit ADC to monitor and digitize the temperature to 0.0078°C of resolution. The ADC resolution, by default, is set to 13 bits (0.0625°C). An internal temperature sensor generates a voltage proportional to absolute temperature, which is compared to an internal voltage reference and input into a precision digital modulator.

The internal temperature sensor has high accuracy and linearity over the entire rated temperature range without needing correction or calibration by the user.

The sensor output is digitized by a sigma-delta (Σ - Δ) modulator, also known as the charge balance type analog-to-digital converter. This type of converter utilizes time-domain oversampling and a high accuracy comparator to deliver 16 bits of resolution in an extremely compact circuit.

CONVERTER DETAILS

The Σ - Δ modulator consists of an input sampler, a summing network, an integrator, a comparator, and a 1-bit DAC. This architecture creates a negative feedback loop and minimizes the integrator output by changing the duty cycle of the comparator output in response to input voltage changes. The comparator samples the output of the integrator at a much higher rate than the input sampling frequency. This oversampling spreads the quantization noise over a much wider band than that of the input signal, improving overall noise performance and increasing accuracy.

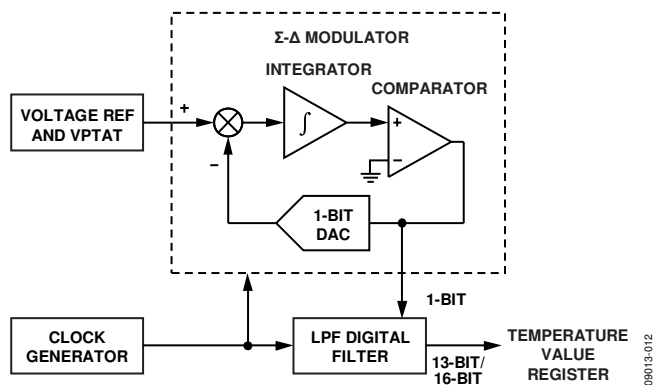

Figure 11. Σ - Δ Modulator

The ADT7420 can be configured to operate in any one of the following four operating modes: normal, one-shot, 1 SPS, and shutdown.

NORMAL MODE

In normal mode (default power-up mode) the ADT7420 runs an automatic conversion sequence. During this automatic conversion sequence, a conversion typically takes 240 ms to complete and the ADT7420 is continuously converting. This means that as soon as one temperature conversion is completed, another temperature conversion begins. Each temperature conversion result is stored in the temperature value registers and is available through the I²C interface. In continuous conversion mode, the read operation provides the most recent converted result.

On power-up, the first conversion is a fast conversion, taking typically 6 ms. If the temperature exceeds 147°C, the CT pin asserts low. If the temperature exceeds 64°C, the INT pin asserts low. Fast conversion temperature accuracy is typically within $\pm 5^\circ\text{C}$.

The conversion clock for the part is generated internally. No external clock is required except when reading from and writing to the serial port.

The measured temperature value is compared with a critical temperature limit (stored in the 16-bit T_{CRIT} setpoint read/write register), a high temperature limit (stored in the 16-bit T_{HIGH} setpoint read/write register), and a low temperature limit (stored in the 16-bit T_{LOW} setpoint read/write register). If the measured value exceeds these limits, the INT pin is activated; and if it exceeds the T_{CRIT} limit, the CT pin is activated. The INT and CT pins are programmable for polarity via the configuration register, and the INT and CT pins are also programmable for interrupt mode via the configuration register.

ONE-SHOT MODE

Setting Bit 6 to 0 and Bit 5 to 1 of the configuration register (Register Address 0x03) enables the one-shot mode. When this mode is enabled, the ADT7420 immediately completes a conversion and then goes into shutdown mode.

Wait for a minimum of 240 ms after writing to the operation mode bits before reading back the temperature from the temperature value register. This time ensures that the ADT7420 has time to power up and complete a conversion.

To obtain an updated temperature conversion, reset Bit 6 to 0 and Bit 5 to 1 in the configuration register (0x03).

The one-shot mode is useful when one of the circuit design priorities is to reduce power consumption.

CT and INT Operation in One-Shot Mode

See Figure 12 for more information on one-shot CT pin operation for T_{CRIT} overtemperature events when one of the limits is exceeded. Note that in interrupt mode, a read from any register resets the INT and CT pins.

For the INT pin in the comparator mode, if the temperature drops below the $T_{HIGH} - T_{HYST}$ value or goes above the $T_{LOW} + T_{HYST}$ value, a write to the operation mode bits (Bit 5 and Bit 6 of the configuration register, Register Address 0x03) resets the INT pin.

For the CT pin in the comparator mode, if the temperature drops below the $T_{CRIT} - T_{HYST}$ value, a write to the operation mode bits (Bit 6 = 0 and Bit 5 = 1 of the configuration register, Register Address 0x03) resets the CT pin (see Figure 12).

Note that when using one-shot mode, ensure that the refresh rate is appropriate to the application being used.

1 SPS MODE

In this mode, the part performs one measurement per second. A conversion takes only 60 ms typically, and it remains in the idle state for the remaining 940 ms period. This mode is enabled by writing 1 to Bit 6 and 0 to Bit 5 of the configuration register (Register Address 0x03).

SHUTDOWN

The ADT7420 can be placed in shutdown mode by writing 1 to Bit 6 and 1 to Bit 5 of the configuration register (Register Address 0x03), in which case the entire IC is shut down and no further conversions are initiated until the ADT7420 is taken out of shutdown mode. The ADT7420 can be taken

out of shutdown mode by writing 0 to Bit 6 and 0 to Bit 5 in the configuration register (Register Address 0x03). The ADT7420 typically takes 1 ms (with a 0.1 μ F decoupling capacitor) to come out of shutdown mode. The conversion result from the last conversion prior to shutdown can still be read from the ADT7420 even when it is in shutdown mode. When the part is taken out of shutdown mode, the internal clock is started and a conversion is initiated.

FAULT QUEUE

Bit 0 and Bit 1 of the configuration register (Register Address 0x03) are used to set up a fault queue. The queue can facilitate up to four fault events to prevent false tripping of the INT and CT pins when the ADT7420 is used in a noisy temperature environment. The number of faults set in the queue must occur consecutively to set the INT and CT outputs. For example, if the number of faults set in the queue is four, then four consecutive temperature conversions must occur with each result exceeding a temperature limit in any of the limit registers before the INT and CT pins are activated. If two consecutive temperature conversions exceed a temperature limit and the third conversion does not, the fault count is reset back to zero.

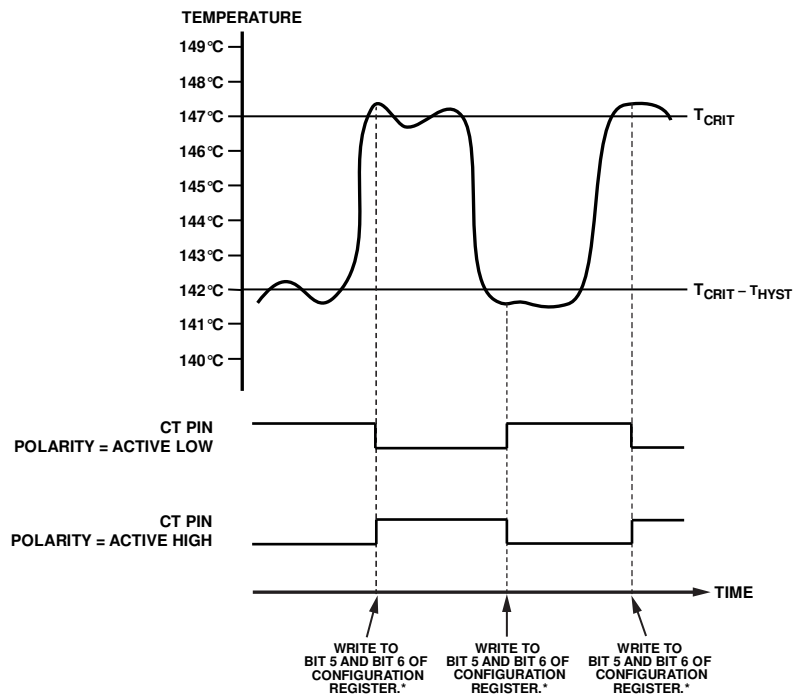

*THERE IS A 240ms DELAY BETWEEN WRITING TO THE CONFIGURATION REGISTER TO START A STANDARD ONE-SHOT CONVERSION AND THE CT PIN GOING ACTIVE. THIS IS DUE TO THE CONVERSION TIME. THE DELAY IS 60ms IN THE CASE OF A ONE-SHOT CONVERSION.

Figure 12. One-Shot CT Pin

09013-013

TEMPERATURE DATA FORMAT

One LSB of the ADC corresponds to 0.0625°C in 13-bit mode or 0.0078°C in 16-bit mode. The ADC can theoretically measure a temperature range of 255°C, but the ADT7420 is guaranteed to measure a low value temperature limit of –40°C to a high value temperature limit of +150°C. The temperature measurement result is stored in the 16-bit temperature value register and is compared with the high temperature limits stored in the T_{CRIT} setpoint register and the T_{HIGH} setpoint register. It is also compared with the low temperature limit stored in the T_{LOW} setpoint register.

Temperature data in the temperature value register, the T_{CRIT} setpoint register, the T_{HIGH} setpoint register, and the T_{LOW} setpoint register are represented by a 13-bit twos complement word. The MSB is the temperature sign bit. The three LSBs, Bit 0 to Bit 2, on power-up, are not part of the temperature conversion result and are flag bits for T_{CRIT}, T_{HIGH}, and T_{LOW}. Table 5 shows the 13-bit temperature data format without Bit 0 to Bit 2.

The number of bits in the temperature data-word can be extended to 16 bits, twos complement, by setting Bit 7 to 1 in the configuration register (Register Address 0x03). When using a 16-bit temperature data value, Bit 0 to Bit 2 are not used as flag bits and are, instead, the LSB bits of the temperature value. The power-on default setting has a 13-bit temperature data value.

Reading back the temperature from the temperature value register requires a 2-byte read. Designers that use a 9-bit temperature data format can still use the ADT7420 by ignoring the last four LSBs of the 13-bit temperature value. These four LSBs are Bit 6 to Bit 3 in Table 5.

Table 5. 13-Bit Temperature Data Format

Temperature	Digital Output (Binary) Bits[15:3]	Digital Output (Hex)
–40°C	1 1101 1000 0000	0x1D80
–25°C	1 1110 0111 0000	0x1E70
–0.0625°C	1 1111 1111 1111	0x1FFF
0°C	0 0000 0000 0000	0x000
+0.0625°C	0 0000 0000 0001	0x001
+25°C	0 0001 1001 0000	0x190
+105°C	0 0110 1001 0000	0x690
+125°C	0 0111 1101 0000	0x7D0
+150°C	0 1001 0110 0000	0x960

TEMPERATURE CONVERSION FORMULAS

16-Bit Temperature Data Format

$$\text{Positive Temperature} = \text{ADC Code (dec)} / 128$$

$$\text{Negative Temperature} = (\text{ADC Code (dec)} - 65,536) / 128$$

where *ADC Code* uses all 16 bits of the data byte, including the sign bit.

$$\text{Negative Temperature} = (\text{ADC Code (dec)} - 32,768) / 128$$

where Bit 15 (sign bit) is removed from the ADC code.

13-Bit Temperature Data Format

$$\text{Positive Temperature} = \text{ADC Code (dec)} / 16$$

$$\text{Negative Temperature} = (\text{ADC Code (dec)} - 8192) / 16$$

where *ADC Code* uses the first 13 MSBs of the data byte, including the sign bit.

$$\text{Negative Temperature} = (\text{ADC Code (dec)} - 4096) / 16$$

where Bit 15 (sign bit) is removed from the ADC code.

10-Bit Temperature Data Format

$$\text{Positive Temperature} = \text{ADC Code (dec)} / 2$$

$$\text{Negative Temperature} = (\text{ADC Code (dec)} - 1024) / 2$$

where *ADC Code* uses all 10 bits of the data byte, including the sign bit.

$$\text{Negative Temperature} = (\text{ADC Code (dec)} - 512) / 2$$

where Bit 9 (sign bit) is removed from the ADC code.

9-Bit Temperature Data Format

$$\text{Positive Temperature} = \text{ADC Code (dec)}$$

$$\text{Negative Temperature} = \text{ADC Code (dec)} - 512$$

where *ADC Code* uses all nine bits of the data byte, including the sign bit.

$$\text{Negative Temperature} = \text{ADC Code (dec)} - 256$$

where Bit 8 (sign bit) is removed from the ADC code.

REGISTERS

The ADT7420 contains 14 registers:

- Nine temperature registers
- A status register
- An ID register
- A configuration register
- An address pointer register
- A software reset

All registers are eight bits wide. The temperature value registers, the status register, and the ID register are read-only. The software reset is a write-only register. On power-up, the address pointer register is loaded with 0x00 and points to the temperature value most significant byte register (Register Address 0x00).

Table 6. ADT7420 Registers

Register Address	Description	Power-On Default
0x00	Temperature value most significant byte	0x00
0x01	Temperature value least significant byte	0x00
0x02	Status	0x00
0x03	Configuration	0x00
0x04	T _{HIGH} setpoint most significant byte	0x20 (64°C)
0x05	T _{HIGH} setpoint least significant byte	0x00 (64°C)
0x06	T _{LOW} setpoint most significant byte	0x05 (10°C)
0x07	T _{LOW} setpoint least significant byte	0x00 (10°C)
0x08	T _{CRIT} setpoint most significant byte	0x49 (147°C)
0x09	T _{CRIT} setpoint least significant byte	0x80 (147°C)
0x0A	T _{HYST} setpoint	0x05 (5°C)
0x0B	ID	0xCB
0x2F	Software reset	0xFF

Table 8. Temperature Value MSB Register (Register Address 0x00)

Bit	Default Value	Type	Name	Description
[14:8]	0000000	R	Temp	Temperature value in twos complement format
15	0	R	Sign	Sign bit, indicates if the temperature value is negative or positive

ADDRESS POINTER REGISTER

This register is always the first register written to during a write to the ADT7420. It should be set to the address of the register to which the write or read transaction is intended. Table 7 shows the register address of each register on the ADT7420. The default value of the address pointer register is 0x00.

Table 7. Address Pointer Register

P7	P6	P5	P4	P3	P2	P1	P0
ADD7	ADD6	ADD5	ADD4	ADD3	ADD2	ADD1	ADD0

TEMPERATURE VALUE REGISTERS

The temperature value consists of two bytes, one most significant byte and one least significant byte. These values can be read in two separate 1-byte reads or in a single 2-byte read. For a 2-byte read, only the address of the most significant byte must be loaded into the address pointer register. After the most significant byte is read, the address pointer is auto-incremented so that the least significant byte can read within the same transaction.

Bit 0 to Bit 2 are event alarm flags for T_{LOW}, T_{HIGH}, and T_{CRIT}. When the ADC is configured to convert the temperature to a 16-bit digital value, then Bit 0 to Bit 2 are no longer used as flag bits and are instead used as the LSBs for the extended digital value.

Table 9. Temperature Value LSB Register (Register Address 0x01)

Bit	Default Value	Type	Name	Description
0	0	R	T _{LOW} flag/LSB0	Flags a T _{LOW} event if the configuration register, Register Address 0x03[7] = 0 (13-bit resolution). When the temperature value is below T _{LOW} , this bit is set to 1. Contains the Least Significant Bit 0 of the 15-bit temperature value if the configuration register, Register Address 0x03[7] = 1 (16-bit resolution).
1	0	R	T _{HIGH} flag/LSB1	Flags a T _{HIGH} event if the configuration register, Register Address 0x03[7] = 0 (13-bit resolution). When the temperature value is above T _{HIGH} , this bit is set to 1. Contains the Least Significant Bit 1 of the 15-bit temperature value if the configuration register, Register Address 0x03[7] = 1 (16-bit resolution).
2	0	R	T _{CRIT} flag/LSB2	Flags a T _{CRIT} event if the configuration register, Register Address 0x03[7] = 0 (13-bit resolution). When the temperature value exceeds T _{CRIT} , this bit is set to 1. Contains the Least Significant Bit 2 of the 15-bit temperature value if the configuration register, Register Address 0x03[7] = 1 (16-bit resolution).
[7:3]	00000	R	Temp	Temperature value in two's complement format.

STATUS REGISTER

This 8-bit read-only register reflects the status of the overtemperature and undertemperature interrupts that can cause the CT and INT pins to go active. It also reflects the status of a temperature conversion operation. The interrupt flags in this register are reset by a read operation to the status register and/or when the temperature value returns within the temperature limits, including hysteresis. The RDY bit is reset after a read from the temperature value register. In one-shot and 1 SPS modes, the RDY bit is reset after a write to the operation mode bits.

Table 10. Status Register (Register Address 0x02)

Bit	Default Value	Type	Name	Description
[3:0]	0000	R	Unused	Reads back 0.
4	0	R	T _{LOW}	This bit is set to 1 when the temperature goes below the T _{LOW} temperature limit. The bit clears to 0 when the status register is read and/or when the temperature measured goes back above the limit set in the setpoint T _{LOW} + T _{HYST} registers.
5	0	R	T _{HIGH}	This bit is set to 1 when the temperature goes above the T _{HIGH} temperature limit. The bit clears to 0 when the status register is read and/or when the temperature measured goes back below the limit set in the setpoint T _{HIGH} - T _{HYST} registers.
6	0	R	T _{CRIT}	This bit is set to 1 when the temperature goes above the T _{CRIT} temperature limit. This bit clears to 0 when the status register is read and/or when the temperature measured goes back below the limit set in the setpoint T _{CRIT} - T _{HYST} registers.
7	1	R	RDY	This bit goes low when the temperature conversion result is written into the temperature value register. It is reset to 1 when the temperature value register is read. In one-shot and 1 SPS modes, this bit is reset after a write to the operation mode bits.

CONFIGURATION REGISTER

This 8-bit read/write register stores various configuration modes for the ADT7420, including shutdown, overtemperature and undertemperature interrupts, one-shot, continuous conversion, interrupt pins polarity, and overtemperature fault queues.

Table 11. Configuration Register (Register Address 0x03)

Bit	Default Value	Type	Name	Description
[1:0]	00	R/W	Fault queue	These two bits set the number of undertemperature/overtemperature faults that can occur before setting the INT and CT pins. This helps to avoid false triggering due to temperature noise. 00 = 1 fault (default). 01 = 2 faults. 10 = 3 faults. 11 = 4 faults.
2	0	R/W	CT pin polarity	This bit selects the output polarity of the CT pin. 0 = active low. 1 = active high.
3	0	R/W	INT pin polarity	This bit selects the output polarity of the INT pin. 0 = active low. 1 = active high.
4	0	R/W	INT/CT mode	This bit selects between comparator mode and interrupt mode. 0 = interrupt mode 1 = comparator mode
[6:5]	00	R/W	Operation mode	These two bits set the operational mode for the ADT7420. 00 = continuous conversion (default). When one conversion is finished, the ADT7420 starts another. 01 = one shot. Conversion time is typically 240 ms. 10 = 1 SPS mode. Conversion time is typically 60 ms. This operational mode reduces the average current consumption. 11 = shutdown. All circuitry except interface circuitry is powered down.
7	0	R/W	Resolution	This bit sets up the resolution of the ADC when converting. 0 = 13-bit resolution. Sign bit + 12 bits gives a temperature resolution of 0.0625°C. 1 = 16-bit resolution. Sign bit + 15 bits gives a temperature resolution of 0.0078°C.

T_{HIGH} SETPOINT REGISTERS

The T_{HIGH} setpoint MSB and T_{HIGH} setpoint LSB registers store the overtemperature limit value. An overtemperature event occurs when the temperature value stored in the temperature value register exceeds the value stored in this register. The INT pin is activated if an overtemperature event occurs. The temperature is stored in twos complement format with the MSB being the temperature sign bit.

When reading from this register, the eight most significant bits (Bit 15 to Bit 8) are read first from Register Address 0x04 and then the eight least significant bits (Bit 7 to Bit 0) are read from Register Address 0x05 (T_{HIGH} setpoint LSB). Only Register Address 0x04 (T_{HIGH} setpoint MSB) needs to be loaded into the address pointer register because the address pointer auto-increments to Register Address 0x05 (T_{HIGH} setpoint LSB).

The default setting for the T_{HIGH} setpoint is 64°C.

T_{LOW} SETPOINT REGISTERS

The T_{LOW} setpoint MSB and T_{LOW} setpoint LSB registers store the undertemperature limit value. An undertemperature event occurs when the temperature value stored in the temperature value register is less than the value stored in this register. The INT pin is activated if an undertemperature event occurs. The temperature is stored in twos complement format with the MSB being the temperature sign bit.

When reading from this register, the eight most significant bits (Bit 15 to Bit 8) are read first from Register Address 0x06 and then the eight least significant bits (Bit 7 to Bit 0) are read from Register Address 0x07. Only Register Address 0x06 (T_{LOW} setpoint MSB) needs to be loaded into the address pointer register because the address pointer auto-increments to Register Address 0x07 (T_{LOW} setpoint LSB).

The default setting for the T_{LOW} setpoint is 10°C.

T_{CRIT} SETPOINT REGISTERS

The T_{CRIT} setpoint MSB and T_{CRIT} setpoint LSB registers store the critical overtemperature limit value. A critical overtemperature event occurs when the temperature value stored in the temperature value register exceeds the value stored in this register. The CT pin is activated if a critical overtemperature event occurs. The temperature is stored in twos complement format with the MSB being the temperature sign bit.

When reading from this register, the eight most significant bits (Bit 15 to Bit 8) are read first from Register Address 0x08 (T_{CRIT} setpoint MSB) and then the eight least significant bits (Bit 7 to Bit 0) are read from Register Address 0x09 (T_{CRIT} setpoint LSB). Only Register Address 0x08 (T_{CRIT} setpoint MSB) needs to be loaded into the address pointer register because the address pointer auto-increments to Register Address 0x09 (T_{CRIT} setpoint LSB). The default setting for the T_{CRIT} limit is 147°C.

Table 12. T_{HIGH} Setpoint MSB Register (Register Address 0x04)

Bit	Default Value	Type	Name	Description
[15:8]	0x20	R/W	T _{HIGH} MSB	MSBs of the overtemperature limit, stored in twos complement format.

Table 13. T_{HIGH} Setpoint LSB Register (Register Address 0x05)

Bit	Default Value	Type	Name	Description
[7:0]	0x00	R/W	T _{HIGH} LSB	LSBs of the overtemperature limit, stored in twos complement format.

Table 14. T_{LOW} Setpoint MSB Register (Register Address 0x06)

Bit	Default Value	Type	Name	Description
[15:8]	0x05	R/W	T _{LOW} MSB	MSBs of the undertemperature limit, stored in twos complement format.

Table 15. T_{LOW} Setpoint LSB Register (Register Address 0x07)

Bit	Default Value	Type	Name	Description
[7:0]	0x00	R/W	T _{LOW} LSB	LSBs of the undertemperature limit, stored in twos complement format.

Table 16. T_{CRIT} Setpoint MSB Register (Register Address 0x08)

Bit	Default Value	Type	Name	Description
[15:8]	0x49	R/W	T _{CRIT} MSB	MSBs of the critical overtemperature limit, stored in twos complement format.

Table 17. T_{CRIT} Setpoint LSB Register (Register Address 0x09)

Bit	Default Value	Type	Name	Description
[7:0]	0x80	R/W	T _{CRIT} LSB	LSBs of the critical overtemperature limit, stored in twos complement format.

T_{HYST} SETPOINT REGISTER

This 8-bit read/write register stores the temperature hysteresis value for the T_{HIGH}, T_{LOW}, and T_{CRIT} temperature limits. The temperature hysteresis value is stored in straight binary format using four LSBs. Increments are possible in steps of 1°C from 0°C to 15°C. The value in this register is subtracted from the T_{HIGH} and T_{CRIT} values and added to the T_{LOW} value to implement hysteresis.

Table 18. T_{HYST} Setpoint Register (Register Address 0x0A)

Bit	Default Value	Type	Name	Description
[3:0]	0101	R/W	T _{HYST}	Hysteresis value, from 0°C to 15°C. Stored in straight binary format. The default setting is 5°C.
[7:4]	0000	R/W	N/A	Not used.

Table 19. ID Register (Register Address 0x0B)

Bit	Default Value	Type	Name	Description
[2:0]	011	R	Revision ID	Contains the silicon revision identification number
[7:3]	11001	R	Manufacture ID	Contains the manufacture identification number

ID REGISTER

This 8-bit read-only register stores the manufacture ID in Bit 3 to Bit 7 and the silicon revision in Bit 0 to Bit 2. The default setting for the ID register is 0xCB.

SERIAL INTERFACE

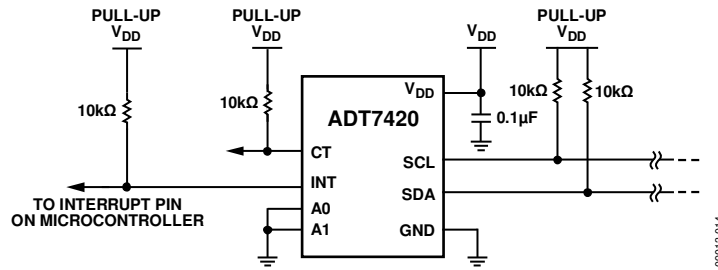

Figure 13. Typical I²C Interface Connection

Control of the ADT7420 is carried out via the I²C-compatible serial interface. The ADT7420 is connected to this bus as a slave and is under the control of a master device.

Figure 13 shows a typical I²C interface connection.

SERIAL BUS ADDRESS

Like most I²C-compatible devices, the ADT7420 has a 7-bit serial address. The five MSBs of this address for the ADT7420 are hardwired internally to 10010. Pin A1 and Pin A0 set the two LSBs. These pins can be configured two ways, low and high, to give four different address options. Table 20 shows the different bus address options available. The recommended pull-up resistor value on the SDA and SCL lines is 10 kΩ.

Table 20. I²C Bus Address Options

Binary							Hex
A6	A5	A4	A3	A2	A1	A0	
1	0	0	1	0	0	0	0x48
1	0	0	1	0	0	1	0x49
1	0	0	1	0	1	0	0x4A
1	0	0	1	0	1	1	0x4B

The serial bus protocol operates as follows:

1. The master initiates data transfer by establishing a start condition, defined as a high-to-low transition on the serial data line, SDA, while the serial clock line, SCL, remains high. This indicates that an address/data stream is going to follow. All slave peripherals connected to the serial bus respond to the start condition and shift in the next eight bits, consisting of a 7-bit address (MSB first) plus a read/write (R/W) bit. The R/W bit determines whether data is written to, or read from, the slave device.

2. The peripheral with the address corresponding to the transmitted address responds by pulling the data line low during the low period before the ninth clock pulse, known as the acknowledge bit. All other devices on the bus then remain idle while the selected device waits for data to be read from or written to it. If the R/W bit is a 0, the master writes to the slave device. If the R/W bit is a 1, the master reads from the slave device.
3. Data is sent over the serial bus in sequences of nine clock pulses, eight bits of data followed by an acknowledge bit from the receiver of data. Transitions on the data line must occur during the low period of the clock signal and remain stable during the high period as a low-to-high transition when the clock is high, which can be interpreted as a stop signal.
4. When all data bytes have been read or written, stop conditions are established. In write mode, the master pulls the data line high during the 10th clock pulse to assert a stop condition. In read mode, the master device pulls the data line high during the low period before the ninth clock pulse. This is known as a no acknowledge. The master takes the data line low during the low period before the 10th clock pulse, then high during the 10th clock pulse to assert a stop condition.

It is not possible to mix read and write in one operation because the type of operation is determined at the beginning and cannot subsequently be changed without starting a new operation.

WRITING DATA

It is possible to write either a single byte of data or two bytes to the ADT7420, depending on which registers are to be written.

Writing a single byte of data requires the serial bus address, the data register address written to the address pointer register, followed by the data byte written to the selected data register. This is shown in Figure 14.

For the T_{HIGH} setpoint, T_{LOW} setpoint, and T_{CRIT} setpoint registers, it is possible to write to both the MSB and the LSB

registers in the same write transaction. Writing two bytes of data to these registers requires the serial bus address, the data register address of the MSB register written to the address pointer register, followed by the two data bytes written to the selected data register. This is shown in Figure 15.

If more than the required number of data bytes is written to a register, the register ignores these extra data bytes. To write to a different register, a start or repeated start is required.

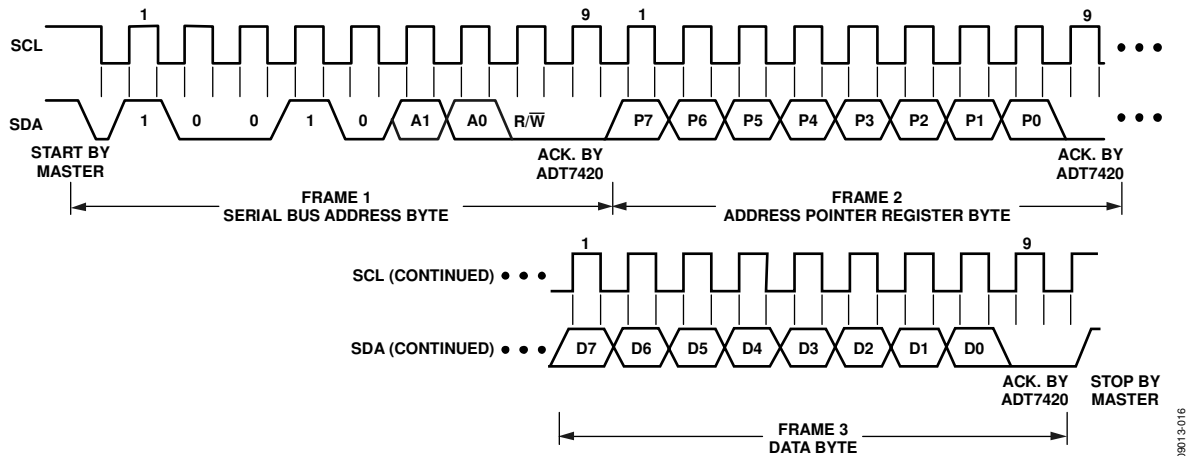

Figure 14. Writing to a Register Followed by a Single Byte of Data

09013-016

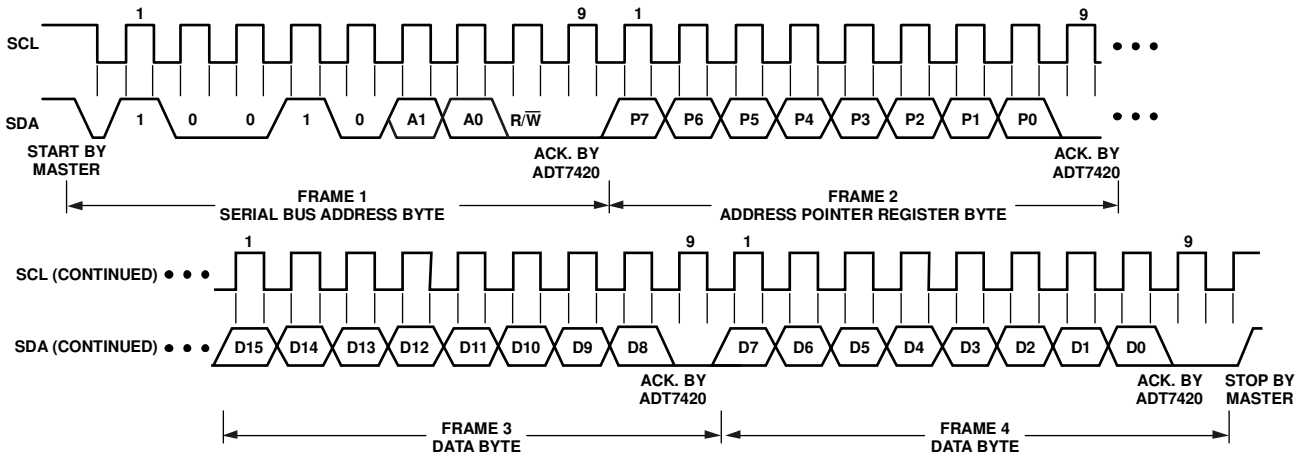

Figure 15. Writing to a Register Followed by Two Bytes of Data

09013-017

READING DATA

Reading data from the ADT7420 is done in a single data byte operation for the configuration register, the status register, the T_{HYST} setpoint register, and the ID register. A two data byte read operation is needed for the temperature value register, T_{HIGH} setpoint register, T_{LOW} setpoint register, and the T_{CRIT} setpoint register. Reading back the contents of an 8-bit register similar to the configuration register is shown in Figure 16. Reading back the contents of the temperature value register is shown in Figure 17.

Reading back from any register first requires a single-byte write operation to the address pointer register to set up the address of

the register that is going to be read from. In the case of reading back from the 2-byte registers, the address pointer automatically increments from the MSB register address to the LSB register address.

To read from another register, execute another write to the address pointer register to set up the relevant register address. Thus, block reads are not possible, that is, there is no I²C address pointer auto-increment except when reading back from a 16-bit register. If the address pointer register has previously been set up with the address of the register that is going to receive a read command, there is no need to repeat a write operation to set up the register address again.

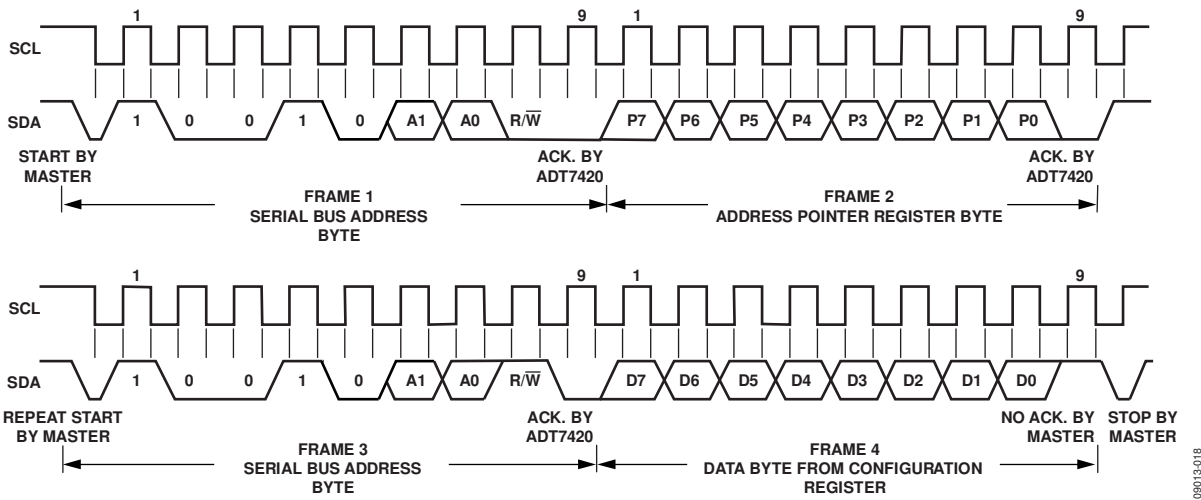
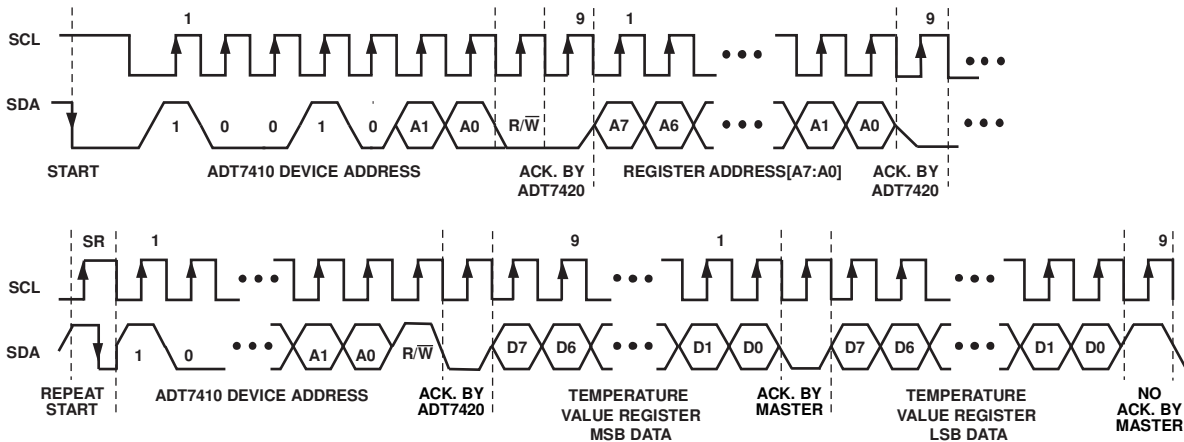

Figure 16. Reading Back Data from the Configuration Register



NOTES

1. A START CONDITION AT THE BEGINNING IS DEFINED AS A HIGH-TO-LOW TRANSITION ON SDA WHILE SCL REMAINS HIGH.
2. A STOP CONDITION AT THE END IS DEFINED AS A LOW-TO-HIGH TRANSITION ON SDA WHILE SCL REMAINS HIGH.
3. THE MASTER GENERATES THE NO ACKNOWLEDGE AT THE END OF THE READBACK TO SIGNAL THAT IT DOES NOT WANT ADDITIONAL DATA.
4. TEMPERATURE VALUE REGISTER MSB DATA AND TEMPERATURE VALUE REGISTER LSB DATA ARE ALWAYS SEPARATED BY A LOW ACK BIT.
5. THE R/W BIT IS SET TO A1 TO INDICATE A READBACK OPERATION.

Figure 17. Reading Back Data from the Temperature Value Register

RESET

To reset the [ADT7420](#) without having to reset the entire I²C bus, an explicit reset command is provided. This uses a particular address pointer word as a command word to reset the part and upload all default settings. The [ADT7420](#) does not respond to (does not acknowledge) I²C bus commands while the default values upload for approximately 200 μ s. Use the following sequence to perform a reset:

1. Write to the [ADT7420](#) using the appropriate address.
2. Get acknowledge.
3. Set the register address to 0x2F.
4. Get acknowledge.
5. Apply stop condition.
6. Wait 200 μ s for the part to reset its registers to the default power-up settings.

GENERAL CALL

When a master issues a slave address consisting of seven 0s with the eighth bit (R/W bit) set to 0, this is known as the general call address. The general call address is for addressing every device connected to the I²C bus. The [ADT7420](#) acknowledges this address and reads in the following data byte.

If the second byte is 0x06, the [ADT7420](#) is reset, completely uploading all default values. The [ADT7420](#) does not respond to the I²C bus commands (do not acknowledge) while the default values upload for approximately 200 μ s.

The [ADT7420](#) does not acknowledge any other general call commands.

INT AND CT OUTPUTS

The INT and CT pins are open-drain outputs, and both pins require a 10 kΩ pull-up resistor to V_{DD}. The ADT7420 must be fully powered up to V_{DD} before reading INT and CT data.

UNDERTEMPERATURE AND OVERTEMPERATURE DETECTION

The INT and CT pins have two undertemperature/overtemperature modes: comparator mode and interrupt mode. The interrupt mode is the default power-up overtemperature mode. The INT output pin becomes active when the temperature is greater than the temperature stored in the T_{HIGH} setpoint register or less than the temperature stored in the T_{LOW} setpoint register. How this pin reacts after this event depends on the overtemperature mode selected.

Figure 18 illustrates the comparator and interrupt modes for events exceeding the T_{HIGH} limit with both pin polarity settings. Figure 19 illustrates the comparator and interrupt modes for events exceeding the T_{LOW} limit with both pin polarity settings.

Comparator Mode

In comparator mode, the INT pin returns to its inactive status when the temperature drops below the T_{HIGH} - T_{HYST} limit or rises above the T_{LOW} + T_{HYST} limit.

Putting the ADT7420 into shutdown mode does not reset the INT state in comparator mode.

Interrupt Mode

In interrupt mode, the INT pin goes inactive when any ADT7420 register is read. Once the INT pin is reset, it goes active again only when the temperature is greater than the temperature stored in the T_{HIGH} setpoint register or less than the temperature stored in the T_{LOW} setpoint register.

Placing the ADT7420 into shutdown mode resets the INT pin in the interrupt mode.

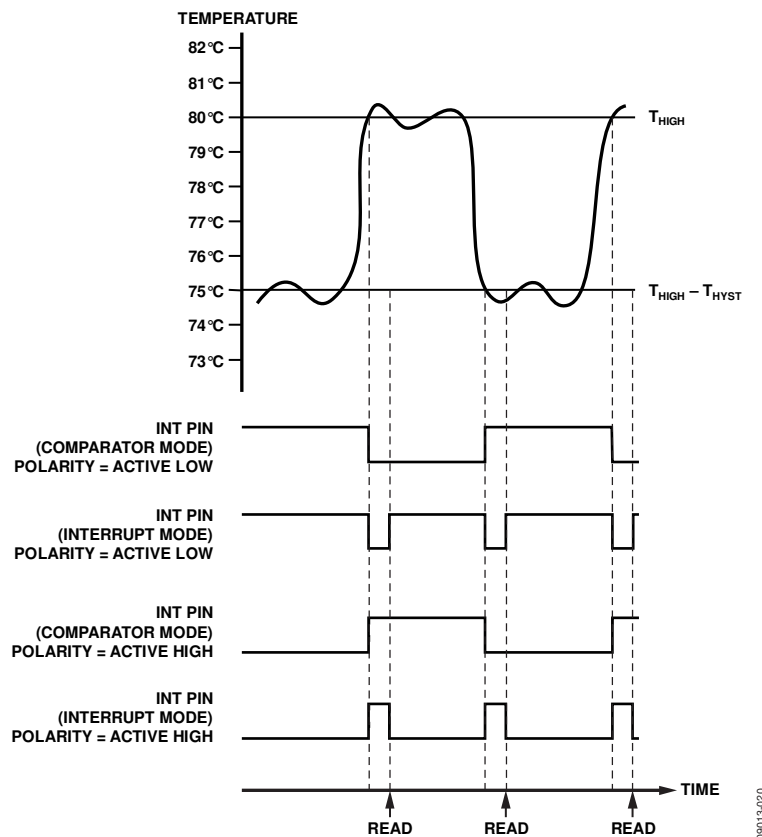

Figure 18. INT Output Temperature Response Diagram for T_{HIGH} Overtemperature Events

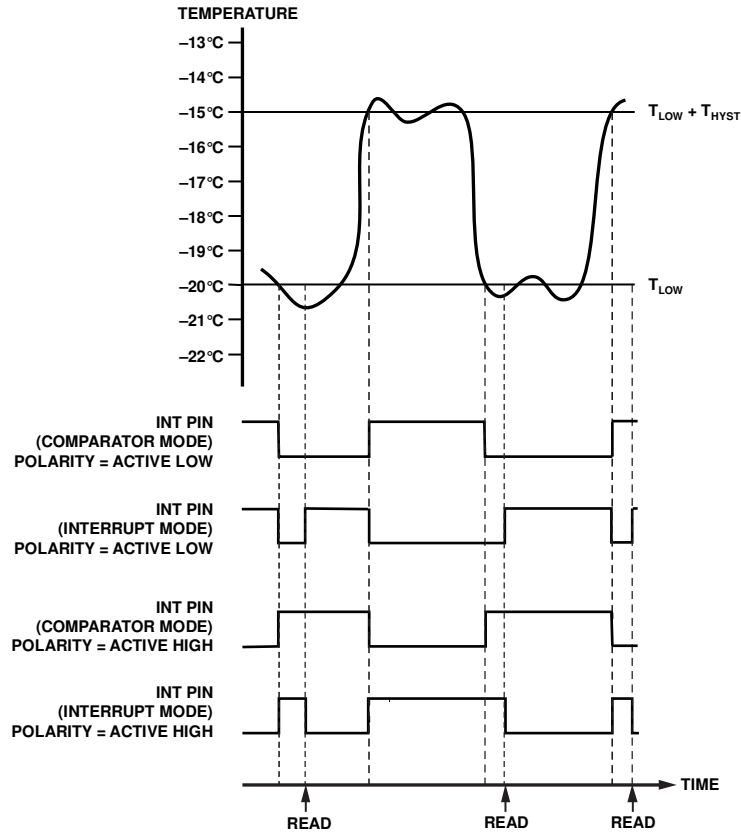

Figure 19. INT Output Temperature Response Diagram for T_{LOW} Undertemperature Events

APPLICATIONS INFORMATION

THERMAL RESPONSE TIME

Thermal response is a function of the thermal mass of the temperature sensor, but it is also heavily influenced by the mass of the object the IC is mounted to. For example, a large PCB containing large amounts of copper tracking can act as a large heat sink and slow the thermal response. For a faster thermal response, it is recommended to mount the sensor on as small a PCB as possible.

Figure 10 shows the typical response time of less than two seconds to reach 63.2% of its temperature span. The temperature value is read back as a 16-bit value through the digital interface. The response time includes all delays incurred on chip during signal processing.

SUPPLY DECOUPLING

The ADT7420 must have a decoupling capacitor connected between V_{DD} and GND; otherwise, incorrect temperature readings will be obtained. A 0.1 μF decoupling capacitor such as a high frequency ceramic type must be used and mounted as close as possible to the V_{DD} pin of the ADT7420.

If possible, the ADT7420 should be powered directly from the system power supply. This arrangement, shown in Figure 20, isolates the analog section from the logic-switching transients. Even if a separate power supply trace is not available, generous supply bypassing reduces supply-line induced errors. Local supply bypassing consisting of a 0.1 μF ceramic capacitor is critical for the temperature accuracy specifications to be achieved.

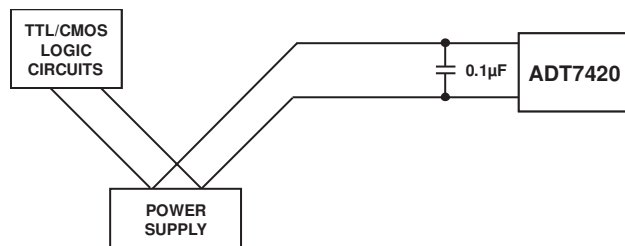

Figure 20. Use of Separate Traces to Reduce Power Supply Noise

09013-022

POWERING FROM A SWITCHING REGULATOR

Precision analog devices such as the ADT7420 require a well-filtered power source. If the ADT7420 is powered from a switching regulator, noise may be generated above 50 kHz that may affect the temperature accuracy specifications. To prevent this, an RC filter should be used between the power supply and ADT7420 V_{DD} . The value of components used should be carefully considered to ensure that the peak value of the supply noise is less than 1 mV. The RC filter should be mounted as far away as possible from the ADT7420 to ensure that the thermal mass is kept as low as possible.

TEMPERATURE MEASUREMENT

The ADT7420 accurately measures and converts the temperature at the surface of its own semiconductor chip. Thermal paths run through the leads, the exposed pad, as well as the plastic package. When the ADT7420 is used to measure the temperature of a nearby heat source, the thermal impedance between the heat source and the ADT7420 must be considered because this impacts the accuracy and thermal response of the measurement.

For air or surface temperature measurements, take care to isolate the package, leads, and exposed pad from ambient air temperature. Use of a thermally conductive adhesive can help to achieve a more accurate surface temperature measurement.

QUICK GUIDE TO MEASURING TEMPERATURE

The following is a quick guide for measuring temperature in continuous conversion mode (default power-up mode). Execute each step sequentially.

1. After powering up the ADT7420, verify the setup by reading the device ID (Register Address 0x0B). It should read 0xCB.
2. After consistent consecutive readings are obtained from Step 1, proceed to read the configuration register (0x03), T_{CRIT} (0x08, 0x09), T_{HIGH} (0x04, 0x05), and T_{LOW} (0x06, 0x07) registers. Compare to the specified defaults in Table 6. If all the readings match, the interface is operational.
3. Write to the configuration register to set the ADT7420 to the desired configuration.
4. Read the temperature value MSB register, followed by the temperature value LSB register. Both registers should produce a valid temperature measurement.

OUTLINE DIMENSIONS

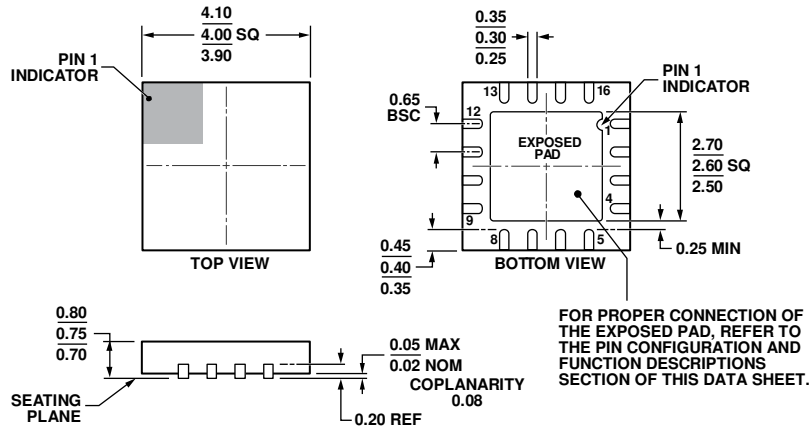

COMPLIANT TO JEDEC STANDARDS MO-220-WGGC.

Figure 21. 16-Lead Lead Frame Chip Scale Package [LFCSP_WQ]
 4 mm × 4 mm Body, Very Thin Quad
 (CP-16-17)
 Dimensions shown in millimeters

012809-B

ORDERING GUIDE

Model ¹	Operating Temperature Range	Package Description	Package Option
ADT7420UCPZ-R2	-40°C to +150°C	16-lead LFCSP_WQ	CP-16-17
ADT7420UCPZ-RL7	-40°C to +150°C	16-lead LFCSP_WQ	CP-16-17
EVAL-ADT7X20EBZ		Evaluation Board	

¹ Z = RoHS Compliant Part.