

## Synchronizing Multiple AD9852 DDS-Based Synthesizers

by David Brandon

### INTRODUCTION

Many applications require the generation of two or more sinusoidal or square wave signals with a known phase relationship between them. The AD9852 DDS IC from Analog Devices is capable of providing such signals. This application note offers detailed instructions on how to synchronize two or more of these devices and considers possible sources of phase error. For a quadrature application, see the AD9854 DDS with its built-in quadrature configuration; however, this application note would also apply to the AD9854 as well.

For successful synchronization, the user must have control over the timing relationship between REFCLK and the rising edge of the EXT I/O UPDATE CLK. The goal is to have all DDSs operating on the same SYSTEM CLK count and not off by  $\pm 1$  or more counts from each DDS. Therefore, the EXT I/O UPDATE CLK must be made synchronous with the REFCLK.

For phase errors due to DAC output filtering mismatches, the AD9852 features programmable phase adjust that can null out these types of mismatches.

### REF CLOCK

The first requirement for successful synchronization of multiple AD9852s is that there must be minimal phase error between the REFCLK inputs to all DDSs. Any difference in-phase between the REFCLK edges will result in a proportional phase difference at the DDS outputs. Therefore, the user must employ a careful clock distribution practice in the layout of the PCB (see Figure 1).

The AD9852 REFCLK input circuitry has an option of using differential inputs or a single-ended configuration. Differential REFCLK mode is recommended for its optimum switching characteristics. The REFCLK edges should have minimum input jitter and fast rise/fall times (less than 1 ns is recommended). A slow rise time on REFCLK can increase the phase error time because the voltage trip point of the input circuit varies from device to device.

OPTIMUM LAYOUT

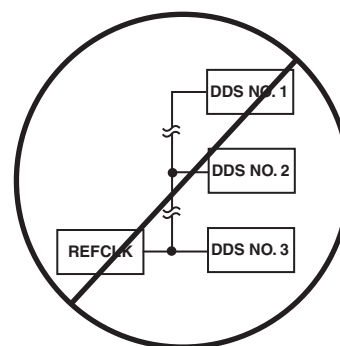
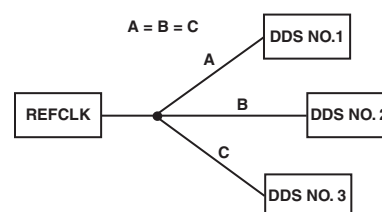

Figure 1. REFCLK Distribution

### I/O UPDATE CLOCK

The I/O UPDATE CLK is responsible for transferring the contents of the I/O port buffer to the programming registers where the data becomes active. This clock has two modes of operation in which the DDS can supply the I/O UPDATE CLK, or the user can supply it. For synchronization reasons, external mode is highly recommended. Internal mode was not given consideration for complexity reasons.

### AD9852 I/O INTERFACE DETAILS

Once a fast-edged and properly routed REFCLK signal is provided, the next timing requirement is the coincident transfer of the data into the DDS programming registers. The I/O UPDATE CLK transfers the contents of the I/O port buffer to the programming registers where data becomes active. Synchronization of multiple DDSs requires that the EXT I/O UPDATE CLK's rising edge occur simultaneously at all DDSs, just like the REFCLK. In addition, the rising edge of the EXT I/O UPDATE CLK must occur at the proper time with respect to REFCLK.

# AN-605

The AD9852 can be programmed in serial or parallel mode. Figure 2 depicts the parallel mode. If shown, the serial mode would display an additional 7-bit shift register and other support circuitry in front of the parallel data path. However, the main reason for showing this diagram is to view the paths of REFCLK and EXT I/O UPDATE CLK.

A few things to note in Figure 2 are how the SYSTEM CLK is derived and the inversion of REFCLK in single-ended REFCLK mode. Also note, an asynchronous EXT

I/O UPDATE CLK will be made synchronous to the SYSTEM CLK via the edge detection circuitry (see Figure 3). However, it is incumbent upon the user to make it synchronous with the REFCLK to avoid a SYSTEM CLK count mismatch between DDSs.

Depending on the setting of the REFCLK mode (single-ended or differential) and/or the use of the on-chip REFCLK multiplier (PLL), the timing relationship between REFCLK and EXT I/O UPDATE CLK will change. These timing changes will be addressed later.

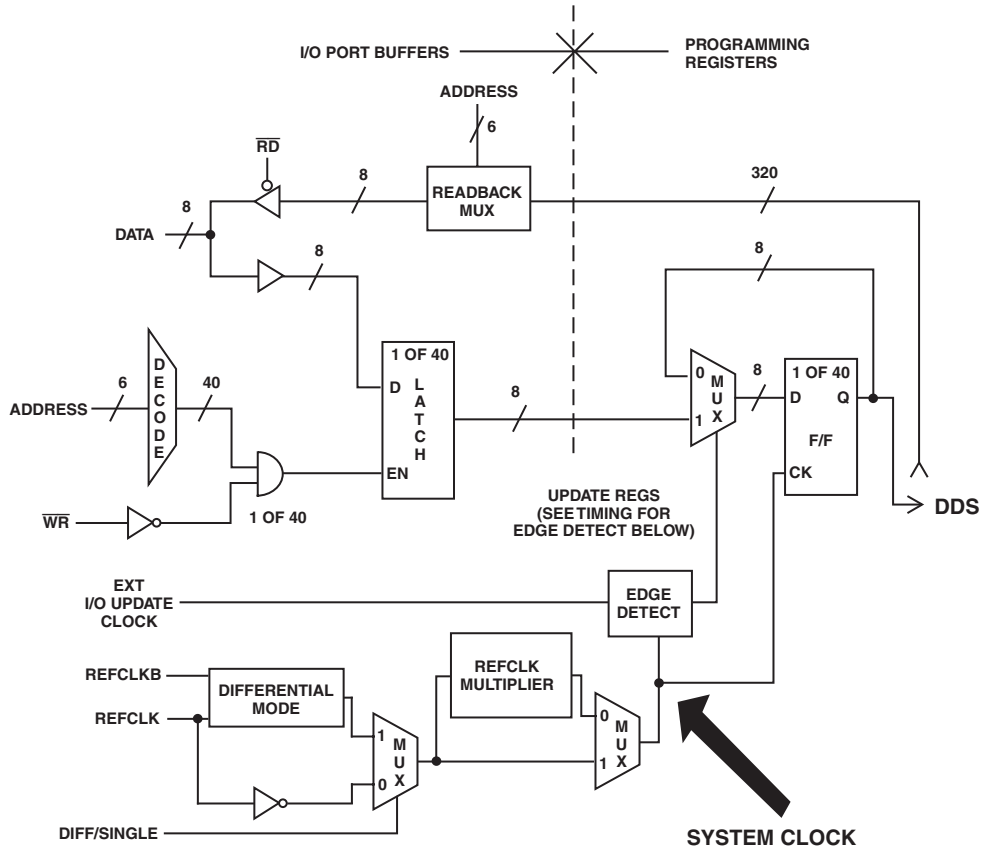

Figure 2. AD9852 Parallel Interface Block Diagram

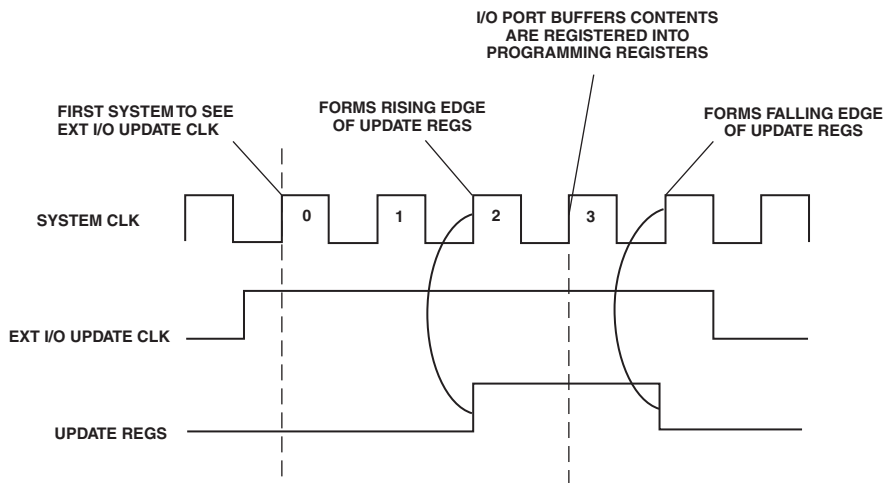

Figure 3. Ext I/O Update CLK's Edge Detect Timing

From the timing in Figure 3, it is essential that a proper time relationship exist between EXT I/O UPDATE CLK and the SYSTEM CLOCK for synchronization to occur. If this time relationship is met, then all SYSTEM CLOCKS are on the same count across all DDSs and not off by  $\pm 1$  or more SYSTEM CLOCK counts. The user would control this relationship with the control of the rising edge of the EXT I/O UPDATE CLK with respect to the REFCLK. This timing relationship will be addressed in the SYNCHRONIZATION INSTRUCTIONS section.

### RESET – BACKGROUND

A RESET must be given after power-up and prior to transferring any data to the DDS. This places the DDS output into a known phase, which becomes the common reference point that allows the synchronization of multiple DDSs.

RESET forces the AD9852's phase accumulator state to become  $\text{COS}(0)$ . When new data is sent simultaneously to multiple DDSs, a coherent phase relationship can be maintained, or the relative phase offset between multiple DDSs can be predictably shifted by means of the phase offset adjustment register. The AD9852 has 14 bits of phase-offset adjustment that amounts to a phase resolution of  $0.022^\circ$ . The phase-offset feature is located between the phase accumulator and the phase-to-amplitude converter.

### SYNCHRONIZATION INSTRUCTIONS

Figure 4 presents one possible reference design for the successful synchronization of multiple DDSs. This example shows how to place two DDSs into the same phase relationship.

In Figure 4, the D flip-flop enables the EXT I/O UPDATE CLK to be synchronous with the REFCLK and provides a setup time. Proper operation may require additional time delay in the REFCLK path. This delay depends on the CK-to-Q propagation time of the flip-flop. The recommended timing relationship between the EXT I/O UPDATE CLK (Pin 20) and the REFCLK (Pin 69) is depicted in Figures 5 and 6, depending on single-ended or differential REFCLK mode. Timing for the REFCLK multiplier enabled is depicted in Figures 8 and 9.

Here are some general instructions and recommendations for placing two DDSs into the same phase relationship (refer to Figure 4).

Note that there are two sets of instructions, with and without the REFCLK multiplier enabled.

Instructions (without the AD9852's REFCLK multiplier enabled) to synchronize two DDSs.

1. Power up all devices and apply the common REFCLK.
2. Send a common RESET with a minimum high time of 10 REFCLK periods.
3. Program all DDSs for EXT I/O UPDATE CLK mode (bypass digital multipliers and inverse sync, if desired).
4. Program DDS No. 1 to the desired frequency and a phase offset of  $0^\circ$  *without* issuing an EXT I/O UPDATE CLK.
5. Program DDS No. 2 to the exact same frequency and a phase offset of  $0^\circ$  *without* issuing an EXT I/O UPDATE CLK.

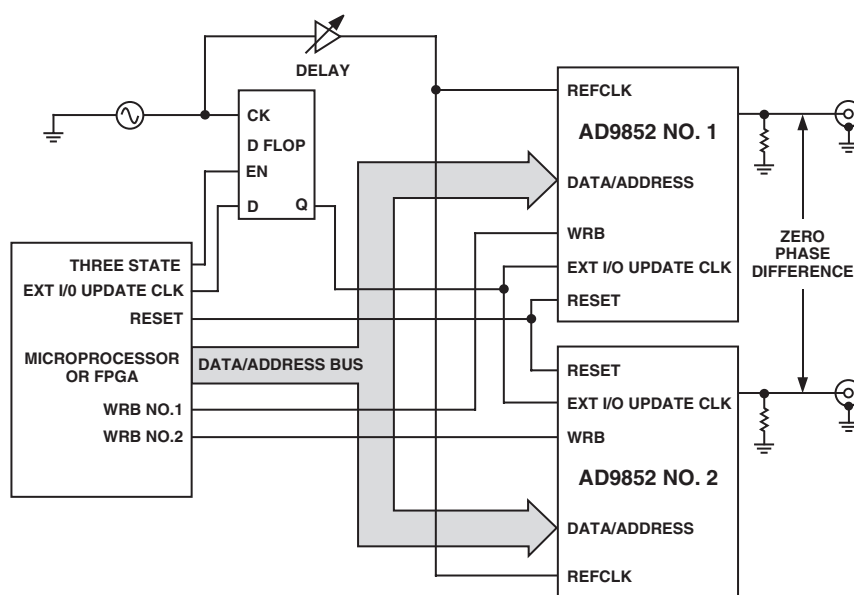

Figure 4. Application Circuit

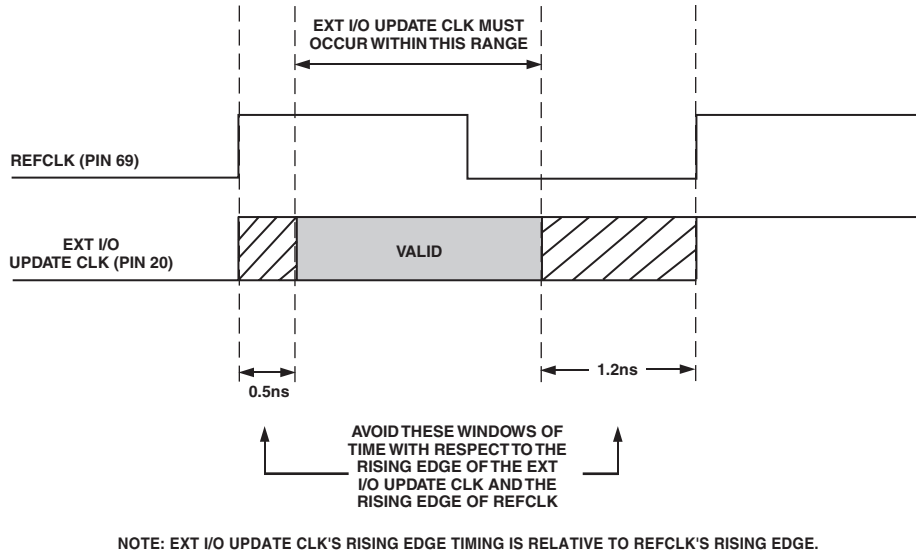

Figure 5. Proper Timing Relationship between REFCLK and EXT I/O Update CLK in Differential REFCLK Mode

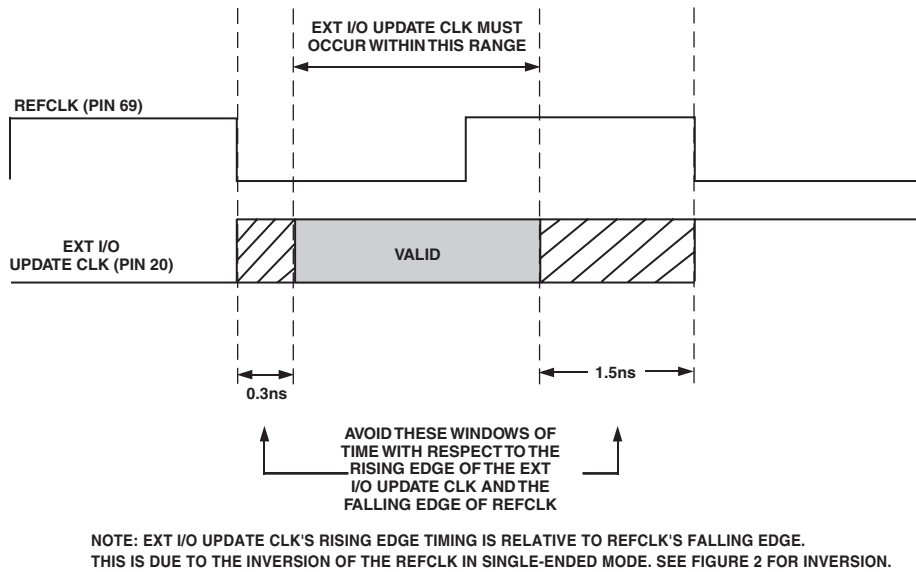

Figure 6. Proper Timing Relationship between REFCLK and EXT I/O Update CLK in Single-Ended REFCLK Mode

6. See the diagrams above for the recommended timing between EXT I/O UPDATE CLK and REFCLK. Choose the appropriate diagram given differential or single-ended REFCLK mode.
7. Assert a *common* EXT I/O UPDATE CLK. This will result in the DAC outputs becoming active simultaneously at the correct frequency and phase offset as programmed.

**USING THE REFCLK MULTIPLIER (PLL) ON THE AD9852**

The REFCLK multiplier of the AD9852 must be used with care when synchronizing multiple DDSs because the PLL lock time will vary from device to device. This means that the number of SYSTEM CLK cycles delivered to the phase accumulator during the PLL lock

interval is not predictable. Therefore, the tuning word must be zero during this time period, which is the default if preceded with a RESET. A tuning word of zero prevents the phase accumulator from incrementing while the PLL locks.

Since all the devices are clocked by a common REFCLK and the PLLs are phase locked to REFCLK, all SYSTEM CLK signals should also be in-phase, assuming a proper REFCLK signal is routed to each DDS as discussed previously.

A typical PLL lock time is approximately 400  $\mu$ s. Due to variations in IC processing and temperature effects on lock time, it is recommended to allow at least 1.0 ms for locking to occur (refer to Figure 7).

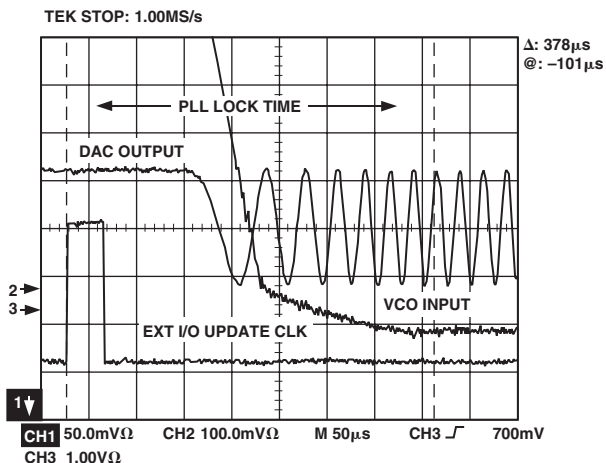
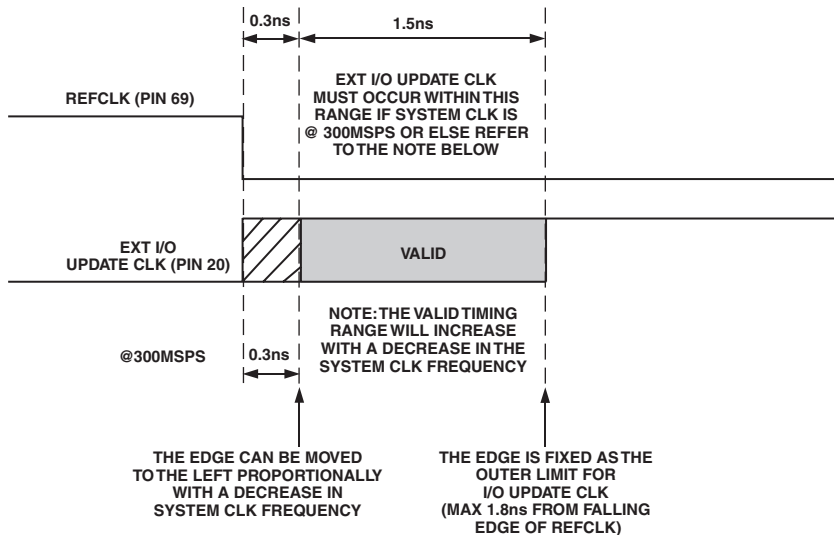

Figure 7. Typical PLL Lock Time

Note: The REFCLK multiplier will lock to the falling edge of REFCLK; therefore, the EXT I/O UPDATE CLK signal should be referenced to the falling edge of REFCLK in differential REFCLK mode and to the rising edge in single-ended mode. The recommended timing relationship between the rising edge of the EXT I/O UPDATE CLK (Pin 20) and the REFCLK (Pin 69) is depicted in Figures 8 and 9.



NOTE: THE RISING EDGE OF EXT I/O UPDATE CLK IS RELATIVE TO THE FALLING EDGE OF REFCLK DUE TO THE FACT THAT THE PLL LOCKS TO THE FALLING EDGE OF REFCLK.

Figure 8. Proper Timing Relationship Using the REFCLK Multiplier in Differential REFCLK Mode

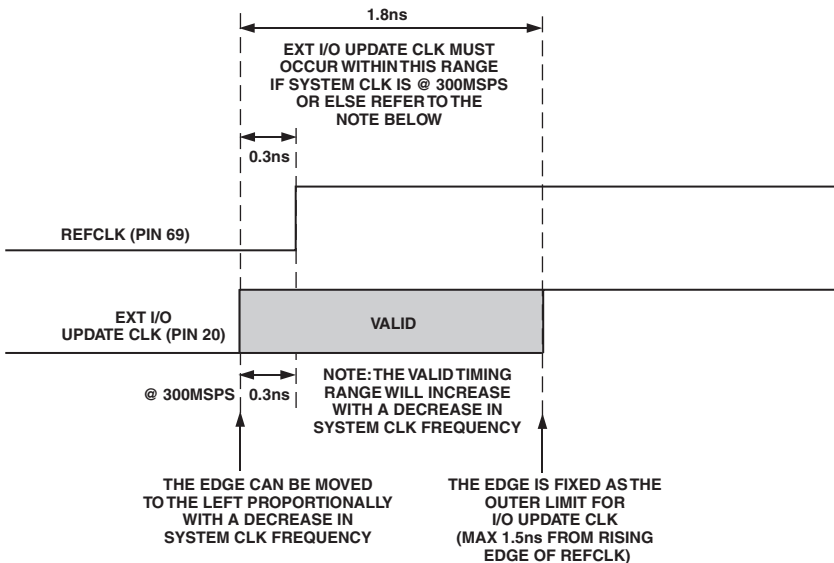

Figure 9. Proper Timing Relationship Using the REFCLK Multiplier in Single-Ended REFCLK Mode

## INSTRUCTIONS WITH THE AD9852'S REFCLK MULTIPLIER ENABLED TO SYNCHRONIZE TWO DDSs.

1. Power up all devices and apply the common REFCLK.
2. Send a common RESET with a minimum high time of 10 REFCLK periods.
3. Program all DDSs for EXT I/O UPDATE CLK mode (bypass digital multipliers and inverse sync, if desired).
4. Program all DDSs for PLL mode along with the REFCLK multiplier value.
5. Send a EXT I/O UPDATE CLK and wait 1.0 ms for PLLs to lock.
6. Program DDS No. 1 to the desired frequency and a phase offset of  $0^\circ$  without issuing an EXT I/O UPDATE CLK.
7. Program DDS No. 2 to the exact same frequency and a phase offset of  $0^\circ$  without issuing an EXT I/O UPDATE CLK.
8. See the diagrams below for the recommended timing between EXT I/O UPDATE CLK and REFCLK. Choose the appropriate diagram for differential or single-ended REFCLK mode.

**IMPORTANT:** Users must remember to keep the REFCLK multiplier enabled as they write each new tuning word and/or phase offset.

9. Assert a common EXT I/O UPDATE CLK. This will result in the DAC outputs becoming active simultaneously at the correct frequency and phase offset as programmed.

## SUMMARY

With proper care and procedure, synchronization can be achieved among multiple DDSs. The following illustrations show how two AD9852s are synchronized to one another. In Figure 10, the REFCLK frequency is set to 100 MHz, and in Figure 11, it is 300 MHz. Both are in non-PLL mode. For Figure 12, REFCLK is set to 75 MHz with the REFCLK multiplier programmed for 43 (System Clock = 300 MHz). Figure 13 shows two DDSs remaining in quadrature, even as the frequency changes are made. Quadrature is denoted by the cursor positioning in Figure 13.

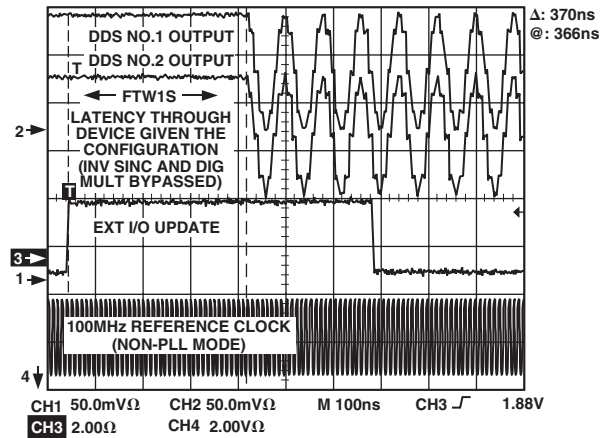

Figure 10. DDS Synchronization – (Conditions:  $V_{CC} = 3.3 V$ , REFCLK = 100 MHz, Non-PLL Mode,  $25^\circ C$ )

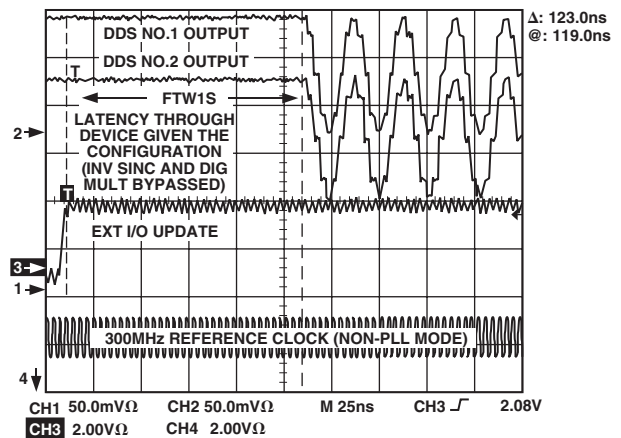

Figure 11. DDS Synchronization – (Conditions:  $V_{CC} = 3.3 V$ , REFCLK = 300 MHz, Non-PLL Mode,  $25^\circ C$ )

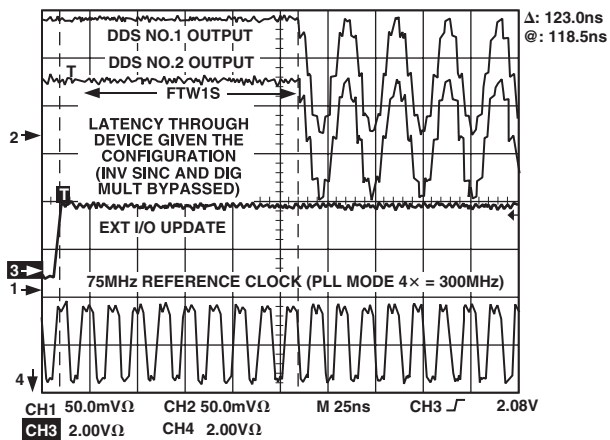

Figure 12. DDS Synchronization – (Conditions:  $V_{CC} = 3.3\text{ V}$ ,  $REFCLK = 75\text{ MHz}$ , PLL (4x) Mode Enable, 25°C)

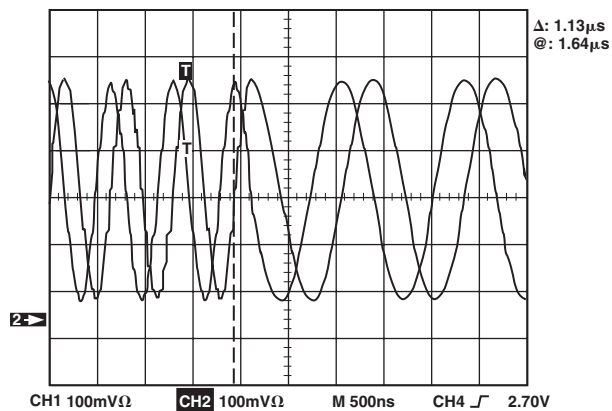

Figure 13. DDS Quadrature Synchronization – (Conditions:  $V_{CC} = 3.3\text{ V}$ ,  $REFCLK = 40\text{ MHz}$ , Non-PLL Mode, 25°C)

