

Multiple Feedback Band-Pass Design Example

by Hank Zumbahlen,
Analog Devices, Inc.

IN THIS MINI TUTORIAL

A multiple feedback band-pass is designed in this mini tutorial, one in a series of mini tutorials describing discrete circuits for op amps.

The multiple feedback topology is widely used as a band-pass filter because it offers a simple and reliable band-pass implementation, especially below a Q of 20 or so. The schematic of a multiple feedback band-pass filter is shown in Figure 1.

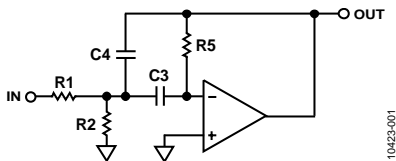

Figure 1. Multiple Feedback Band-Pass

In this example, a filter is designed with an arbitrarily chosen center frequency (F_0) of 1 kHz and a Q of 10. The amplifier gain is arbitrarily set at 1 (0 dB). Note that this does not mean that the output will have a gain less than or equal to the input. In fact, there will be a gain of 10 (20 dB) due to the peaking of the Q of the filter function.

Using the design equations in the Multiple Feedback Band-Pass Design Equations section, one can calculate the appropriate component values. Note that the calculated component values most likely are not standard values.

Select the closest standard values. While this causes some errors, it is typically within specifications. If not, tuning may be required. Tuning of the resonant frequency, F_0 , is possible by making R2 variable. The Q of the circuit (see [MT-210](#)) can be adjusted (with R5) as well, but this also changes F_0 .

Tuning of F_0 can be accomplished by monitoring the output of the filter with the horizontal channel of an oscilloscope, with the input to the filter connected to the vertical channel. The display is a Lissajous pattern. This pattern is an ellipse that collapses to a straight line at resonance, since the phase shift is 180°.

One could also adjust the output for maximum output, which also occurs at resonance, but this is usually not as precise, especially at lower values of Q where there is a less pronounced peak.

MULTIPLE FEEDBACK BAND-PASS DESIGN EQUATIONS

$$\frac{-H \omega_0 s}{s^2 + \alpha \omega_0 s + \omega_0^2}$$

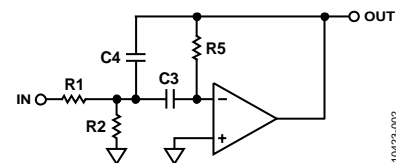

Figure 2.

$$\frac{V_O}{V_{IN}} = \frac{-s \frac{1}{R1 C4}}{s^2 + s \frac{C3 + C4}{C3 C4 R5}} + \frac{1}{R5 C3 C4} \left(\frac{1}{R1} + \frac{1}{R2} \right)$$

Design Flow

Choose C3.

Then

$$k = 2 \pi F_0 C3$$

$$C4 = C3$$

$$R1 = \frac{1}{H k}$$

$$R2 = \frac{1}{(2Q - H) k}$$

$$R5 = \frac{2Q}{k}$$

When selecting the op amp, look for an amp with a gain-bandwidth product sufficient to support the output. In this case, the F_0 is 1 kHz. The peaking due to the filtering function is 20 dB. A 20 dB pad is added to this as a safety fact. Therefore, an op amp with at least 40 dB of open-loop gain at 1 kHz is needed. For this example, an [AD711](#) is arbitrarily chosen.

The open-loop gain of the [AD711](#) is shown in Figure 3. The open-loop gain at 1 kHz is on the order of 65 dB, well over the requirement.

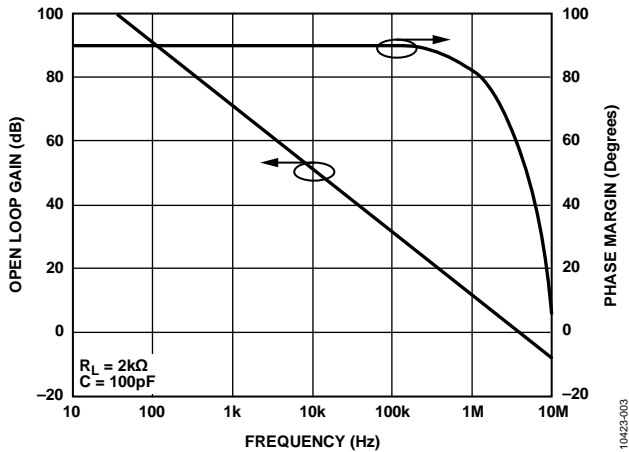

Figure 3. Open-Loop Gain of the AD711

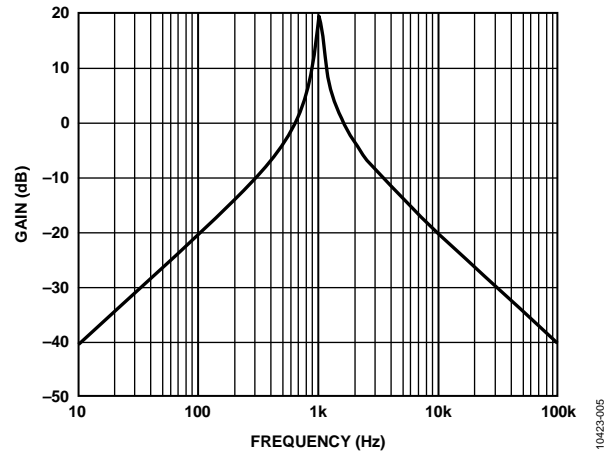

Figure 5.

If the open-loop gain of the op amp is too low, a phenomenon known as Q multiplication takes place and the response of the filter is affected.

MULTIPLE FEEDBACK BAND-PASS FILTER FINAL DESIGN

The final design for the filter is shown in Figure 4. The standard values for the resistors have been substituted. Note that this circuit is shown in National Instrument’s Electronic Workbench. A version of this program can be downloaded from the [Analog Devices website](#). In addition, a group of ready-entered circuits, including this filter, can be download from the same page.

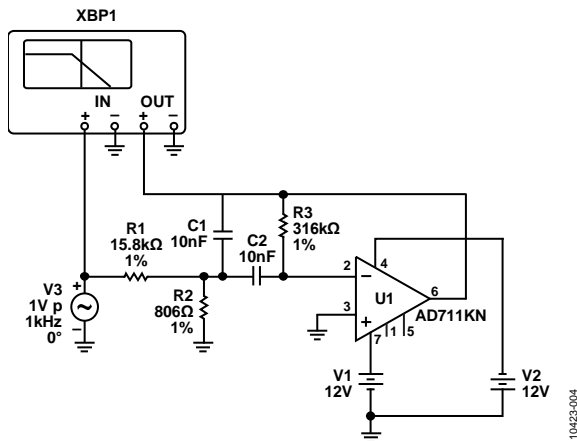

Figure 4.

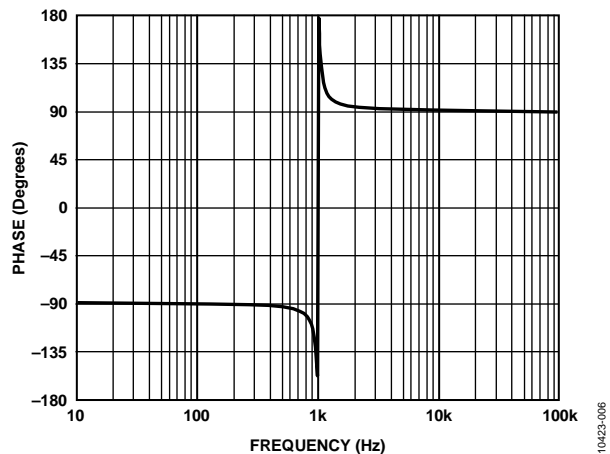

Figure 6.

The voltage of this circuit is shown in Figure 5; the phase response is shown in Figure 6.

REVISION HISTORY

2/12—Revision 0: Initial Version

REFERENCES

- Jung, Walter G., editor. 2006. *Op Amp Applications Handbook*, Newnes, ISBN 0-916550-26-5.
- Kester, Walt, editor. 1992. *Amplifier Applications Guide*, Analog Devices, Inc. ISBN: 0-916550-10-9.
- Zumbahlen, Hank, editor. 2007. *Basic Linear Design*, Analog Devices, Inc. ISBN 0-916550-28-1.
- Zumbahlen, Hank. “Phase Relations in Active Filters.” *Analog Dialogue*, Vol. 14, No. 4, 2008.
- Zumbahlen, Hank, editor, 2008. *Linear Circuit Design Handbook*, Newnes, ISBN 978-0-7506-8703-4.