

DESCRIPTION

Demonstration circuit DC660 is a low noise micro-power voltage regulator using the LTC1844 ultra-low dropout CMOS linear regulator, which comes in a tiny 5-Pin SOT-23 package. The DC660 has an input voltage range from 1.8V to 6.5V, and is capable of delivering 150 mA max. The DC660 is able to use ceramic capacitors, due to the LTC1844 capability of maintaining stability with ultra-low ESR capacitors. With the

small size ceramic capacitors, tiny SOT-23 package of the LTC1844, plus its low quiescent current – maximum 80uA over temperature, the DC660 voltage regulator is ideally suited for hand-held applications, such as cellular phones or PDAs.

Gerber files for this circuit are available. Call the LTC Factory.

QUICK START PROCEDURE

DC660 is easy to set up for evaluating the performance of the LTC1844. For proper measurement equipment configuration, set up the circuit according to the diagram in **Figure 1**.

Please follow the procedure outlined below for proper operation.

1. Before proceeding to test, insert jumper JP1 into the 1.5V option and apply no load across Vout.
2. Apply 1.6V across Vin (to Gnd). Draw 10mA of load current. Measure Vout; it should be 1.5V +/- 2% (1.47V to 1.53V).
3. Vary the input voltage from 1.6V to 6.5V and the load current from 10 mA to 100 mA. Vout should measure 1.5V +/- 4% (1.44V to 1.56V).
4. Turn off the input power and move jumper JP1 into any of the remaining output voltage options: 1.8V, 2.5V, 2.8V, or 3.3V. Re-apply

power, and, just as in the 1.5V test, the output voltage should read Vout +/- 2% tolerance under static line and load conditions, and +/- 4% tolerance under dynamic line and load conditions.

5. When finished evaluating, turn off the input power.

Warning - If long leads are used to power the demo circuit, the input voltage at the part could “ring”. This ringing could affect the operation of the circuit or even exceed the maximum voltage rating of the IC. To eliminate this, insert a small tantalum capacitor (for instance, an AVX part # TAJW226M010R) on the pads between the input power and return terminals on the bottom of the demo board. The (greater) ESR of the tantalum will dampen the (possible) ringing voltage due to the use of long input leads. On a normal, typical PCB, with short traces, the capacitor is not needed.

QUICK START GUIDE FOR DEMONSTRATION CIRCUIT 660

LOW NOISE MICROPOWER LINEAR VOLTAGE REGULATOR

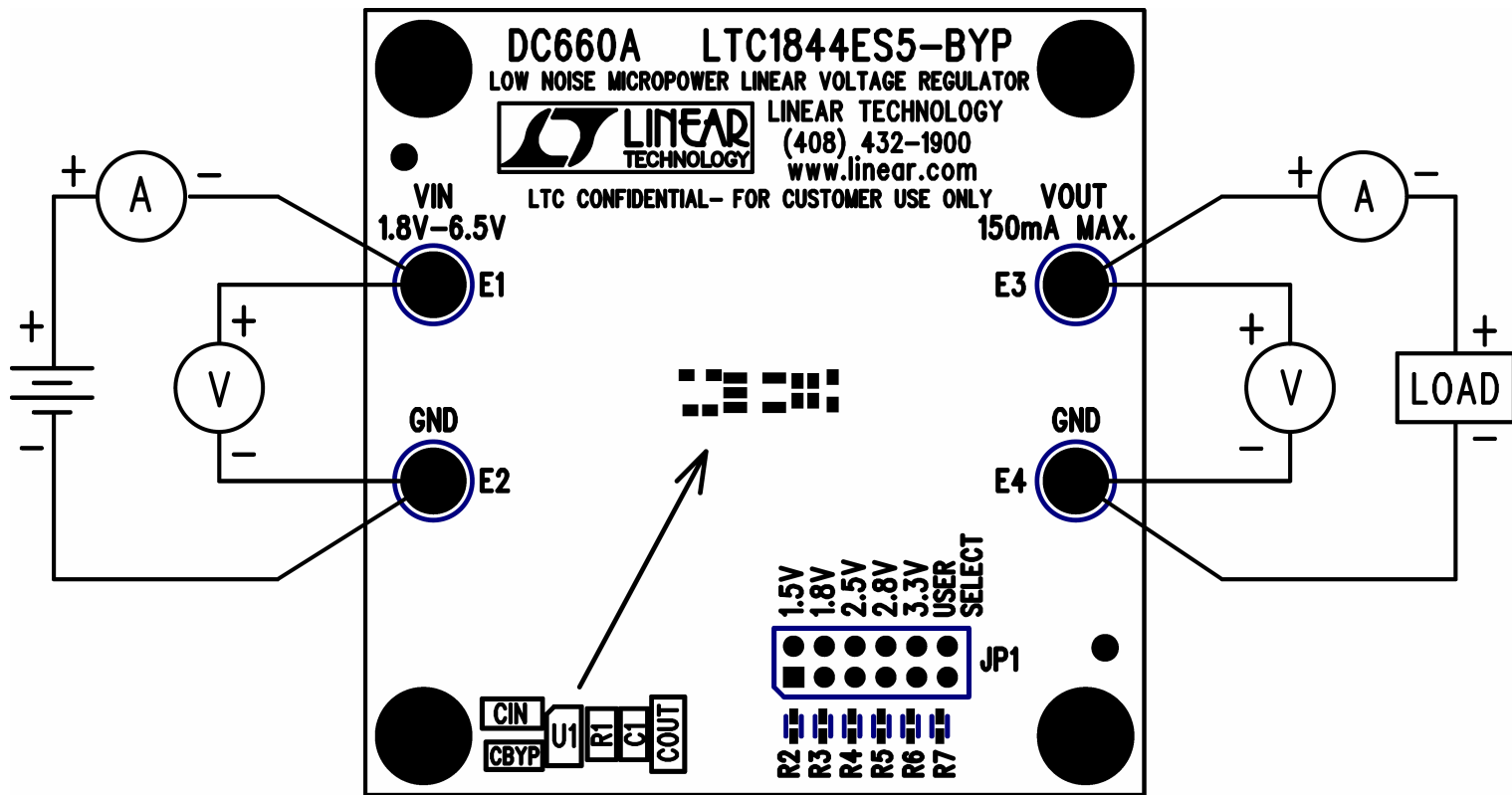

Figure 1. Proper Measurement Equipment Setup

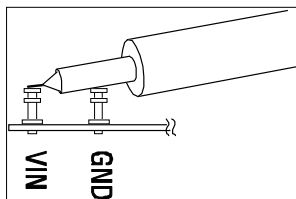
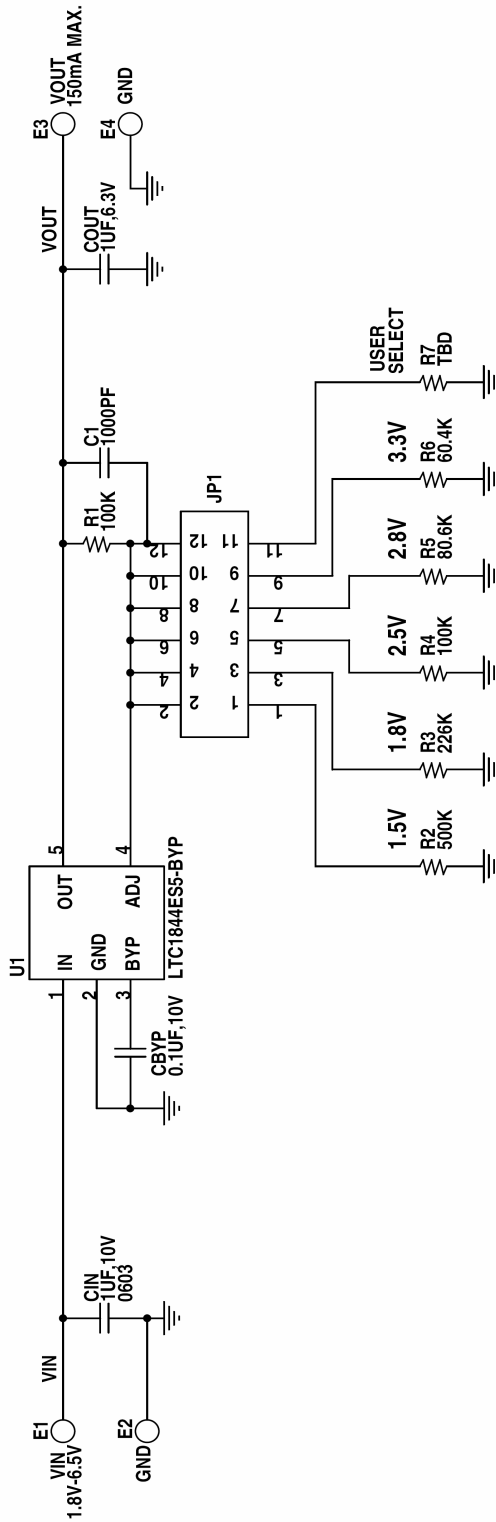

Figure 2. Measuring Input or Output Ripple

QUICK START GUIDE FOR DEMONSTRATION CIRCUIT 660

LOW NOISE MICROPOWER LINEAR VOLTAGE REGULATOR



LINEAR TECHNOLOGY		1630 McCarthy Blvd. Milpitas, CA 95035 Phone: (408)432-1900 Fax: (408)434-0507 LTC Confidential-For Customer Use Only	
CONTRACT NO.		TITLE: SCHEMATIC	
APPROVALS		LOW NOISE MICROPOWER LINEAR VOLTAGE REGULATOR	
DRAWN: KIM.T.		SIZE DWG NO.	REV
CHECKED:		A	A
APPROVED:		DATE: Thursday, August 14, 2003	SHEET 1 OF 1
ENGINEER: TOM.G.			
DESIGNER:			

NOTES: UNLESS OTHERWISE SPECIFIED

1. ALL RESISTORS ARE IN OHMS, 0402.
ALL CAPACITORS ARE IN MICROFARADS, 0402.