

SILICON-BASED GYROSCOPES AND THEIR ACCELEROMETER SIBLINGS ARE INCREASINGLY PREVALENT IN CONSUMER-ELECTRONICS EQUIPMENT. HOWEVER, INACCURACY IN REPORTED DATA MAY PRODUCE AN END-USER EXPERIENCE THAT'S WORSE THAN NOT HAVING A MEMS-BASED SYSTEM AT ALL.

# A SIMPLE CALIBRATION FOR MEMS GYROSCOPES

BY MARK LOONEY • ANALOG DEVICES

**T**raditionally, gyroscopes were mechanical devices that measured the angular rate of rotation. One common use of gyroscopes has been in navigation systems to provide heading estimation. Installing these types of gyroscopes into systems typically involved a mechanical design mounted to a bulkhead, providing a mechanical set-screw system for frame-alignment calibration. MEMS (microelectromechanical-system)-gyroscope technology now provides this function in a variety of packages that enable integration into PCB (printed-circuit-board)-based systems. MEMS gyroscopes employ tiny micromechanical systems on silicon structures, supporting motion-to-electrical transducer functions.

Although MEMS gyroscopes are simpler to integrate into electronic systems than their mechanical predecessors, many factors still require consideration, including trade-offs among function, performance, and price. For many systems, a key performance metric is accuracy. Although off-the-shelf products may satisfy some design requirements, a gyroscope that appears to suit a system design may end up being too inaccurate. Over a population of parts, for example, you can expect sufficient variation in accuracy to negatively affect critical system goals.

Gyroscope calibration offers an option for bridging this gap, enabling the use of an approach that may be more favorable due to price, package style, power dissipation, or other attributes. The purpose of calibration is to translate transducer behaviors

into valuable bits at the system level. A well-designed calibration takes a population of transducer behaviors and produces predictable outputs over the important conditions for the end system. Translating MEMS-gyroscope behaviors into predictable performance at the system level requires you to cultivate an understanding of the transducer's performance and behaviors, establish the impact that the sensor's behaviors will have on critical system-performance criteria, and develop a strategy and process for characterizing and correcting behaviors that can limit the transducer's value in the system.

For system developers in the initial prototype phase, justifying the investment in accurate motor stages, encoders, and stable mechanical structures can be difficult. Although this approach to calibration will not replace the need to invest in proper equipment

for production-ready processing, it will speed development cycles and lower up-front investment requirements.

## MEMS-GYROSCOPE BEHAVIOR

An ideal MEMS gyroscope produces a predictable output when you subject

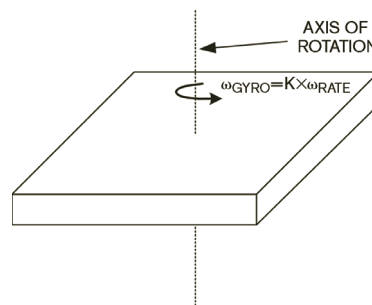

Figure 1 A yaw-rate MEMS gyroscope responds to motion about its predefined axis of rotation.

it to a known rate of rotation. It has no noise, perfect linearity, and no offset. Perfection is not typically available on economical manufacturing processes, however, creating the need for a deeper understanding of MEMS-gyroscope errors. A yaw-rate MEMS gyroscope responds to motion about its predefined axis of rotation (Figure 1). For MEMS gyroscopes, you express the typical unit of measurement for angular rate of rotation in degrees per second. For analog-output products, scale factors are normally in degrees per second per volt or millivolt. For digital products, scale factors are normally in degrees per second per least-significant bit.

The following equation provides a simple behavior model for a MEMS gyroscope:

$$\omega_{\text{GYRO}} = K \times \omega_{\text{RATE}} \times \epsilon + \omega_{\text{BIAS}} + \omega_{\text{NOISE}} + K_2 \times \omega_{\text{RATE}}^2 + K_3 \times \omega_{\text{RATE}}^3 + \dots$$

Product data sheets typically provide information that enables estimates for each error term in this equation. These estimates enable the second step in this process—to determine the system-level impact and establish performance goals.

### SYSTEM-LEVEL IMPACT

After establishing an understanding of the MEMS gyroscope's behaviors and error patterns, you then must determine the impact that they will have on system operation. Setting performance goals that support critical system goals is essential to successful sensor integration. Some systems, such as navigation and platform controls, use the gyroscope outputs to determine relative angle displacement through integration. Bias errors add fixed errors to the sensor's output response and can make a device look like it is rotating when it is stationary. The net result is a constant accumulation of angle-measurement error that is equal to the product of the bias error and time accumulation. The following equation shows the mathematical relationship for this drift factor:

$$\varphi_{\text{BIAS}} = \int_0^t \omega_{\text{BIAS}} \times dt = \omega_{\text{BIAS}} \times t^1$$

Scale-factor errors contribute to displacement-measurement errors only when there is motion. The mathematical relationship for the resulting error is as follows:

$$\varphi_{\text{SCALE}} = \int_0^t \omega_{\text{RATE}} \times K \times \epsilon \times dt = \epsilon \times \int_0^t \omega_{\text{RATE}} \times K \times dt$$

Noise that is inversely proportional to the integration time associated with the measurement contributes random

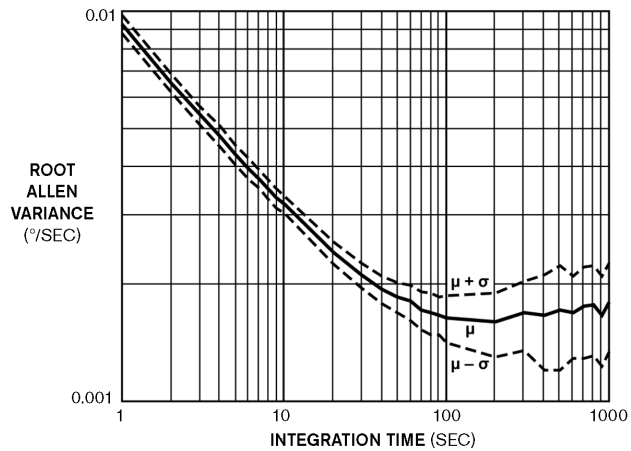

Figure 2 The root Allan Variance graphs noise impact versus integration time of the ADIS16130 MEMS gyroscope.

error to the measurement. A common tool for analyzing this impact is the Allan Variance Method, which establishes the variance for a bias estimate with respect to an integration time. For example, the accuracy for a 6-second integration time is approximately 0.004°/sec (Figure 2).

Bias, noise, and scale-factor errors, including linearity, have a notable impact on systems that use MEMS gyroscopes for angle-displacement measurements (Figure 3).

## Interchangeable Humidity Sensor

with  $\pm 2\%$  RH Accuracy

- best accuracy without calibration
- mass application suitable
- SMD compatible
- integrated temperature sensor
- integrated dust filter

full-size picture

5x5mm (0.2x0.2")

**Technical Data:**

- working range RH: 0...100%RH
- accuracy RH:  $\pm 2\%$  RH
- working range T: -40...+140°C (-40...284°F)
- accuracy T:  $\pm 0.2^\circ\text{C}$  ( $\pm 0.36^\circ\text{F}$ )

**Applications:**

- automotive industry
- climate control

- data loggers
- humidity monitoring

**ISO 9001:2008**  
ISO TS16949:2009 certified

[info@epluse.com](mailto:info@epluse.com)  
[www.epluse.com](http://www.epluse.com)

A-4209 Engerwitzdorf  
Austria

T: +43 7235 605 0  
F: +43 7235 605 8

Sensor Technology

we take up the challenge

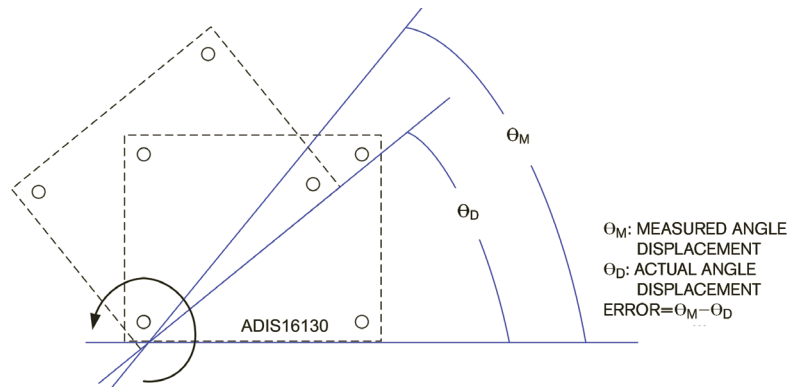

**Figure 3** MEMS-gyroscope errors in variables such as bias, noise, and scale factors impact systems that use them for angle-displacement measurements.

These errors directly influence heading estimates in navigation systems, along with the accuracy of a platform-control system that uses them as a feedback-sensing element.

### SIMPLE CALIBRATION

A common goal for calibration is to narrow the error distribution of a transducer population and transform that population into sensor systems that provide a predictable output for the measured conditions. This procedure involves characterizing individual transducers under known conditions, thereby providing the necessary data for part-specific correction formulas. The purpose of this process is to offer a simple calibration for getting started. A linear-compensation approach, which addresses first-order bias and scale-factor errors, will suffice for reaching less-than-1% composite errors.

Averaging the MEMS-gyroscope output while holding the device in a constant position is a simple method for estimating bias errors. The Allan Variance Curve for a gyroscope helps in analyzing the trade-off between test time—that is, length of average—and bias accuracy. You typically characterize scale-factor errors using a servomotor stage, which employs an optical encoder for precise rate control. In this approach, MEMS gyroscopes rotate at known rates while providing output measurements. Although this approach is effective and probably necessary for later stages of development and production, a simpler

approach exists. Assuming bias-error correction, the integration of a MEMS gyroscope provides another mechanism for observing scale factor. In this case, the scale-factor error is the ratio of the measured angle to the actual angle displacement.

### CALIBRATION EXAMPLE

Practical steps enable using this approach with a gyroscope. This process also works for a system-level board with a surface-mount MEMS gyroscope. Begin the calibration by considering the physical setup:

1. Select a pivot point and secure it with a machine-screw assembly. Experiment with the pivot screw's torque to provide for secure attachment that still allows for smooth rotation on the surface.
2. Install mechanical stops for two angular positions. One idea would be to attach two M2 spacers using M2 machine screws. Set the screws in positions that provide approxi-

mately 90° of rotation motion.

3. Pivot the gyroscope assembly between each stop point to make sure that the rotation is clear and smooth motion is possible.
4. Measure the displacement angle using an independent sensor. One option for this step would be an accelerometer-based inclinometer, such as Analog Devices' ([www.analog.com](http://www.analog.com)) ADIS16209, which you fix to the rotating platform. You then orient the platform vertically and use an inclinometer to measure angular displacement. If the inclinometer's accuracy is 0.25° and the rotation span is 90°, the error will be less than 0.3%.

Once the setup and angle measurements are complete, use the following procedure to measure the gyroscope's behaviors:

1. Power the gyroscope on and allow it to reach thermal stability. Many MEMS gyroscopes provide a temperature sensor for this purpose.
2. Start measuring the output while holding the gyroscope against the first stop position. Continue sampling the output for the following steps.
3. Wait 5 seconds and then turn the gyroscope toward the second stop. Begin with a smooth motion that takes 3 to 4 seconds to move the 90° span.
4. Wait 5 seconds and then rotate the gyro back to the first stop using a similar motion.
5. Wait 5 seconds and then stop the measurements. Save the data.

#### AT A GLANCE

▣ The purpose of MEMS (microelectromechanical-system)-gyroscope calibration is to translate transducer behaviors into valuable bits at the system level.

▣ You must determine the impact of the MEMS gyroscope's behaviors and error patterns on system operation.

▣ The Allan Variance Curve helps in analyzing the trade-off between test time and bias accuracy.

Using the obtained time record, use the following steps to calculate correction factors for this MEMS gyroscope (Figure 4):

1. Calculate the bias-offset-correction factor by averaging the first 3 seconds of data. The bias correction will be the opposite polarity of this average. In this example, the bias-correction factor is  $-8.6^\circ/\text{sec}$ . This correction yields an accuracy of greater than  $0.1^\circ/\text{sec}$  for the bias estimate.
2. Subtract the bias estimate from the time record. Then integrate output data from the 4-second time stamp to the 9-second time stamp. In this case, the measured angle displacement is  $95.1^\circ$ . The scale factor from this step is  $90^\circ$  divided by  $95.1^\circ$ , or 0.946.
3. Using the bias-corrected response from Step 2, integrate output data from the 12-second time stamp to the 16-second time stamp. In this case, the measured angle displacement is  $-95.3^\circ$ . The scale factor from this step is  $90^\circ$  divided by  $95.3^\circ$ , or 0.944.
4. Average the results of steps 2 and 3 to calculate the scale-factor correction, which in this example is 0.945.

Like any other bench-top process, this one requires practice to refine and improve. Experimentation will help refine the speed of rotation, but it is important to make sure that the sensor does not overrange at any point. It is also important to make sure that the surface is smooth, so that the gyro assembly does not jump up and down during the rotation. Another area of sensitivity is in approaching the stop points. If the gyro “bounces” off the stop, it may introduce errors. Using adequate transition times eases the burden of having accurate time stamps. The important thing is to start integrating before the motion begins and to stop integrating after the motion stops.

MEMS gyroscopes are sensitive to acceleration and gravity. Therefore, orientation with respect to gravity is worth consideration. In this example, gravity has the least effect on the gyroscope when you orient the sensor’s axis of rotation to align with gravity. In some cases, power-supply and thermal influences may also need management. In other cases, repeating this process immediately before taking critical measurements will be

sufficient for managing these effects. If not, repeating this process at two power-supply levels and two temperatures will help mitigate the first-order effects.

This MEMS-gyroscope-calibration procedure is relatively simple and requires little investment in equipment. For some systems, this process provides the necessary accuracy. For other applications, the process simplifies the proof-of-concept development phase, helping to justify the investment to subsequently either purchase or calibrate to the necessary accuracy when the final system goes into production. Managing optimal accuracy across a wide range of temperature, power supplies, and other environmental influences will require more investment. **EDN**

#### AUTHOR’S BIOGRAPHY

Mark Looney is an applications engineer with Analog Devices, where his responsibilities include developing literature and application information for advanced inertial-sensing products. Looney obtained a master’s degree in electrical engineering from the University of Nevada, Reno, in 1995.

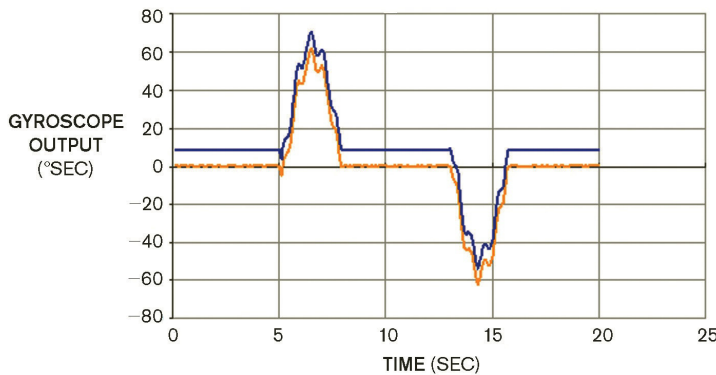

Figure 4 A time record of the MEMS gyroscope’s output behaviors enables the calculation of correction factors.