

Circuits from the Lab
Reference Designs

Circuits from the Lab® reference designs are engineered and tested for quick and easy system integration to help solve today's analog, mixed-signal, and RF design challenges. For more information and/or support, visit www.analog.com/CN0405.

Devices Connected/Referenced

AD5116	Single-Channel, 64-Position, Push-Button, ±8% Resistor Tolerance, Nonvolatile Digital Potentiometer
ADCMP371	General-Purpose Comparator with Push-Pull Output Stage
ADP121	150 mA, Low Quiescent Current, CMOS Linear Regulator

High Voltage Output DAC with Push-Button Control

EVALUATION AND DESIGN SUPPORT

Circuit Evaluation Boards

[CN-0405 Circuit Evaluation Board \(EVAL-CN0405-EB1Z\)](#)

Design and Integration Files

[Schematics](#), [Layout Files](#), [Bill of Materials](#)

CIRCUIT FUNCTION AND BENEFITS

This circuit shown in Figure 1 provides a complete solution that replaces a classical high voltage mechanical potentiometer with a push-button controlled digital potentiometer.

The circuit allows a low voltage digital potentiometer to control a high voltage source up to 20 V from batteries or other sources through simple push-button switches, offering ease of use and optimum power efficiency. The AD5116 digital potentiometer provides 64 wiper positions with an end-to-end resistor tolerance error of ±8%, making it suitable for wide range of adjustment.

In addition, the AD5116 contains an EEPROM that can manually save the wiper position to its desirable position through a push-button. This feature is useful in applications requiring a default position on power-up.

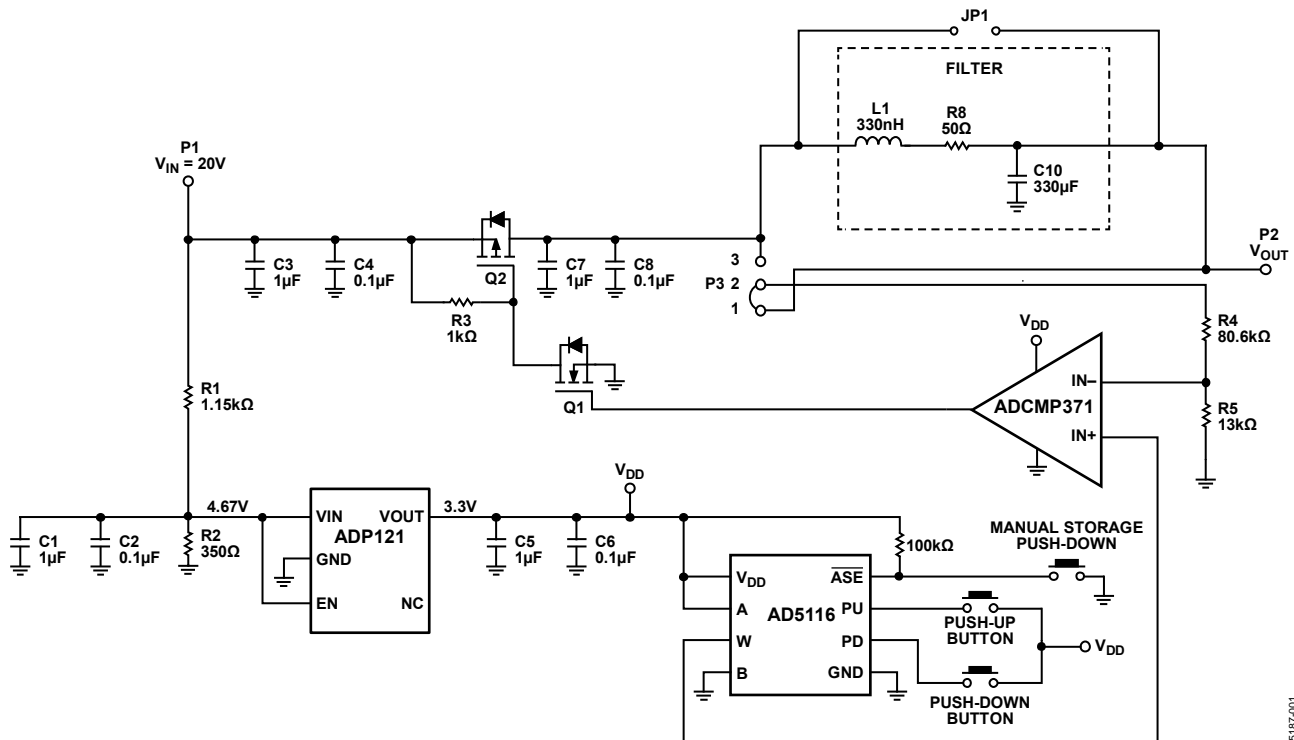

Figure 1. High Voltage DAC Circuit (Simplified Schematic. All Components, Connections, and Decoupling Not Shown)

Rev. 0

Circuits from the Lab reference designs from Analog Devices have been designed and built by Analog Devices engineers. Standard engineering practices have been employed in the design and construction of each circuit, and their function and performance have been tested and verified in a lab environment at room temperature. However, you are solely responsible for testing the circuit and determining its suitability and applicability for your use and application. Accordingly, in no event shall Analog Devices be liable for direct, indirect, special, incidental, consequential or punitive damages due to any cause whatsoever connected to the use of any Circuits from the Lab circuits. (Continued on last page)

CIRCUIT DESCRIPTION

The circuit shown in Figure 1 is a simple, high voltage, variable output switching controller using the [AD5116](#) 64-position digital potentiometer in conjunction with [ADCMP371](#) comparator that has a push-pull output stage and low power consumption suitable for battery-powered portable equipment.

The circuit is powered entirely from the V_{IN} source and accepts an input voltage up to 20 V. The voltage from the divider, R1 and R2, is regulated to 3.3 V using the [ADP121](#), a 30 μ A, low quiescent current, low dropout linear regulator. The regulated 3.3 V supplies the V_{DD} voltage to the [AD5116](#) digital potentiometer and the [ADCMP371](#) comparator.

Circuit Operation

The circuit is a switched mode power supply where the output voltage is regulated by controlling the switching frequency of the feedback network.

The output voltage, V_{OUT} , is controlled with a feedback comparator that compares the R4 and R5 divided output voltage to a reference voltage derived from the wiper of the [AD5116](#) digital potentiometer. The output of the comparator drives the NMOS transistor, Q1, which in turn drives the series pass PMOS transistor, Q2. The negative feedback causes Q2 to switch on and off to force the average voltage at the IN– pin of the comparator to be equal to the voltage on the IN+ pin. There is only a small amount of power dissipated in Q1 and Q2 because they are either on or off.

When the Q1 transistor is on (saturation region), the voltage drop across it is minimal, and when it is off (cutoff region), there is almost no current through the power path. The switching frequency depends on the [AD5116](#) digital-to-analog converter (DAC) output voltage.

When the DAC output is low voltage, Q2 must be open most of the time; therefore, the comparator output must be low most of the time. Under these conditions, the comparator output is a series of short positive-going pulses at a low frequency.

As the DAC output voltage increases, Q2 must be closed for a longer period of time; therefore, the comparator output must be high longer. Under these conditions, the comparator output is a series of faster positive-going output pulses at a higher frequency. The reverse happens if the DAC output voltage is decreased.

Negative feedback forces the average value of the comparator inputs to be equal for any increase or decrease in DAC output voltage.

The filtered output voltage, V_{OUT} , is determined by the following equation:

$$V_{OUT} = V_W \times \left(1 + \frac{R4}{R5} \right) \quad (1)$$

where V_W is the DAC output voltage at the wiper terminal, W.

The [AD5116](#) digital potentiometer generates a divided voltage at wiper to Terminal B that is proportional to the V_{DD} voltage. The resistance between Terminal A and Terminal B is nominally 5 k Ω and is divided to 64 taps. At the lower end of the scale, the typical wiper resistance, R_W , decreases to between 45 Ω and 70 Ω . The output voltage at V_W with respect to GND is

$$V_W = \frac{R_{WB}}{R_{AB}} \times V_A \quad (2)$$

$$R_{WB} = \frac{D}{64} \times R_{AB} + R_W \quad (3)$$

where:

R_{WB} is the wiper resistance at bottom scale.

R_{AB} is the end-to-end resistance.

V_A is the voltage at the top of the divider string, equal to V_{DD} .

D is the decimal equivalent of the binary code in RDAC register.

The RDAC register is controlled using the PD and PU push-buttons. When a desirable wiper position is established, it can be stored to EEPROM memory through the \overline{ASE} push-button, which sets the default position upon power-up.

Filtering Section

To produce a constant dc voltage and reduce the ripple voltage at the output caused by the switching that occurs at the input, an additional filtering circuit is required.

The key in determining the filter design is to determine the maximum and minimum switching frequency and define the ripple considerations, as well as the DAC operating voltage range.

The unfiltered output waveform of the circuit when the filter block is bypassed (JP1 shorted, and C10 not inserted) is shown in Figure 2 and Figure 3 for zero scale and full scale, respectively.

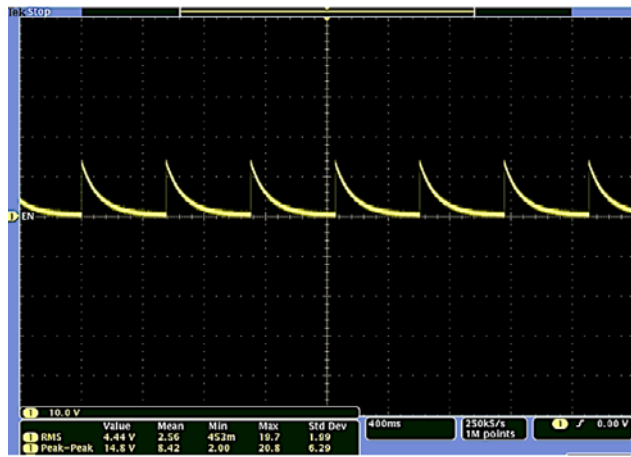

Figure 2. V_{OUT} at Low Voltage, 400 ms/div, 1.8 Hz

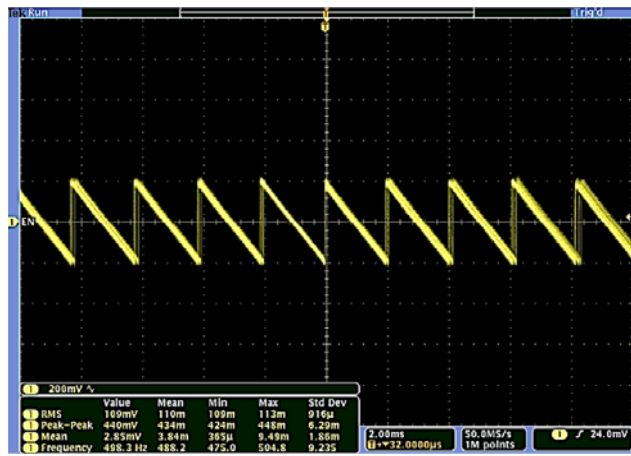

Figure 3. V_{OUT} at High Voltage (AC-Coupled), 2 ms/div, 500 Hz

As shown in Figure 2 and Figure 3, the operating switching frequency of the circuit ranges from approximately 1.8 Hz (lower end of range) to 500 Hz (higher end of range). The switching ripple transients introduced onto the output waveforms can be filtered with a simple filter design that is included in the filter block section of the circuit.

The component values are dependent on the cutoff frequency of the filter. Because the switching frequencies are quite low, relatively large values of R, L, and C are required for a low cutoff frequency. However, the series resistance of the filter forms a voltage divider with the output load that can reduce the output voltage. Therefore, the value of R must be relatively small. The filter design components can be modified depending on the type of application and the load requirements.

A simple RLC low pass filter was implemented to filter the output waveform. R8 and C10 are populated with 50 Ω and 330 μF, and L1 with 100 nH for the RLC filter.

The filtered output waveform is shown in Figure 4 and Figure 5 for high voltage output and low voltage output, respectively.

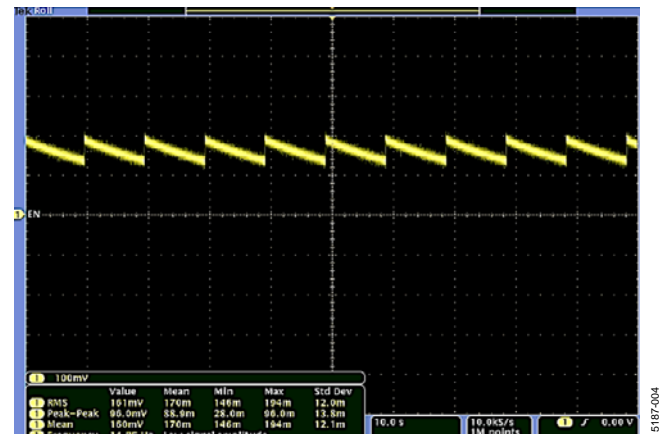

Figure 4. Filtered V_{OUT} (High Voltage) with High-Z Load

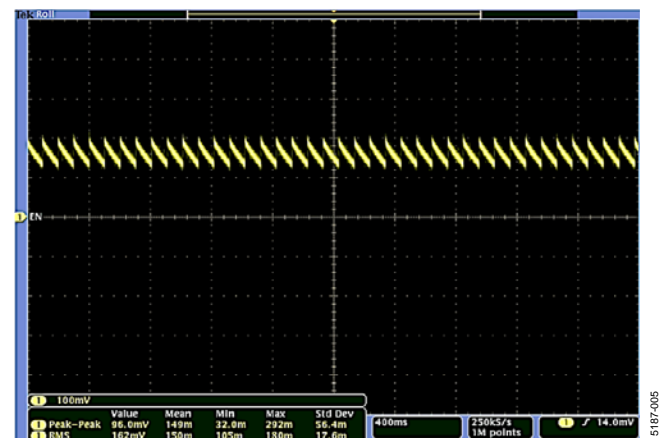

Figure 5. Filtered V_{OUT} (Low Voltage) with 1 kΩ Load

The filtered outputs show that the ripple voltage is approximately 100 mV p-p. Note that the peak-to-peak ripple voltage has the same value for all codes and is not affected by the load connected to the output. The transistor used in this circuit is the IRF9630S transistor; however, it can be replaced by other transistors with the same specifications but with much lower I_{DDS}.

Test Data and Results

The V_{OUT} (rms) plots vs. the DAC code are shown in Figure 6 through Figure 9. These tests were conducted with an RLC filter on the output using the values shown in Figure 1 (50 Ω , 330 nH, and 330 μ F).

Figure 6 shows that the output voltage is limited beyond Code 56 with no load, the point at which the comparator inputs approach the limit of their input common-mode voltage.

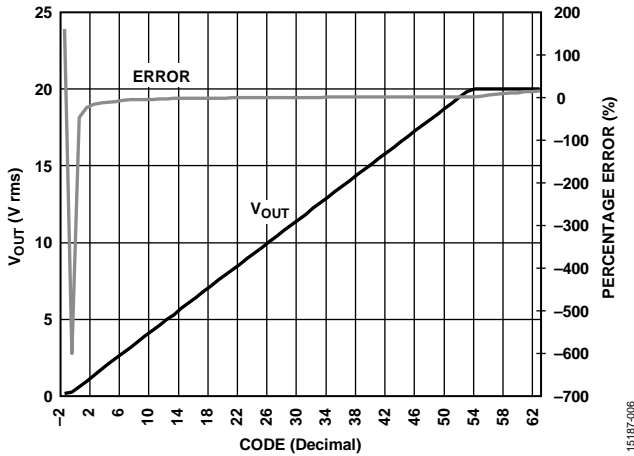

Figure 6. Output Voltage and Error vs. Decimal Code ($V_{IN} = 20\text{ V}$, High-Z Load), Full-Scale DAC Range

Figure 7 shows that the output has an error of $\pm 5\%$ from Code 10 to Code 54. The high percentage error in the lower codes (see Figure 6) is caused by the high offset voltage of the series side transistor, Q2.

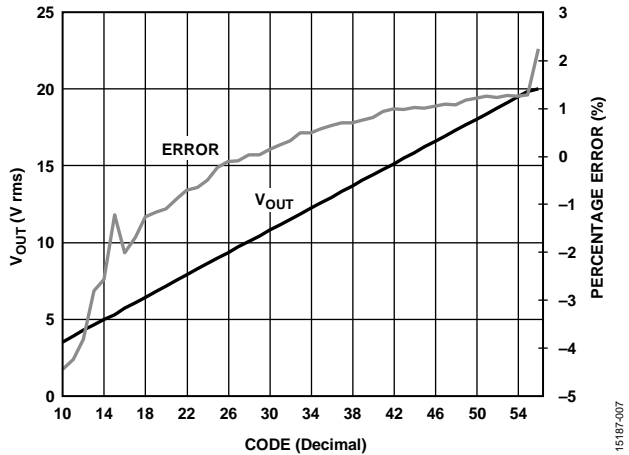

Figure 7. Output Voltage and Error vs. Decimal Code ($V_{IN} = 20\text{ V}$, High-Z Load), DAC in Linear Operating Range

The 50 Ω series resistor forms a voltage divider with the load. The output voltage is limited to 19.01 V with a 1 k Ω load, as shown in Figure 8.

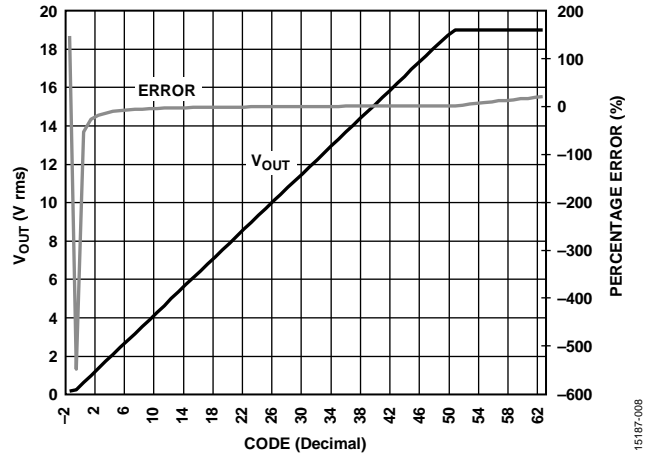

Figure 8. Output Voltage and Error vs. Decimal Code ($V_{IN} = 20\text{ V}$, $R_L = 1\text{ k}\Omega$), Full-Scale DAC Range

Figure 9 shows the response with the output loaded in 1 k Ω over the linear operating range of Code 10 to Code 54.

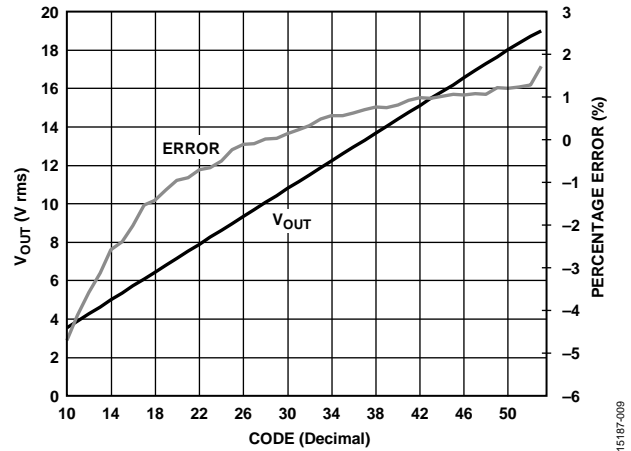

Figure 9. Output Voltage and Error vs. Decimal Code ($V_{IN} = 20\text{ V}$, $R_L = 1\text{ k}\Omega$), DAC in Linear Operating Range

COMMON VARIATIONS

The performance of the circuit can be enhanced by using a pulse-width modulator (PWM) to control the on/off time ratio of the series pass transistor switching, thereby simplifying filtering. The comparator can also be replaced by an error amplifier that controls the PWM. A power transistor with low I_{DSS} can be used to minimize ripple offset voltage at the output. A PWM controller allows greater precision in the output voltage adjustment.

The circuit can also be implemented using a buck converter with adjustable output, such as the ADP2441. The AD5116 serves as the divider that supplies the feedback pin of the buck converter. However, the output voltage must be attenuated by a factor of 4 to limit the AD5116 drive voltage to 5 V.

CIRCUIT EVALUATION AND TEST

The circuit uses the following equipment for circuit evaluation.

Equipment Needed

The following equipment is required:

- [EVAL-CN0405-EB1Z](#) circuit evaluation board
- Agilent E36311A dual dc power supply or equivalent
- Agilent 3458A multimeter or equivalent
- Oscilloscope

Test Setup Functional Block Diagram

Figure 10 shows a functional diagram of the test setup.

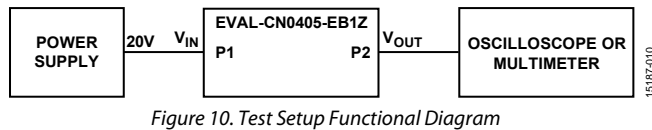

Setup

Take the following steps for circuit evaluation:

1. For filtered output, connect the Pin 1 and Pin 2 link of P3 with a jumper. Remove the JP1 jumper link.
2. For unfiltered output, connect the Pin 2 and Pin 3 link of P3 with a jumper. Install the JP1 jumper link. Remove C10.
3. Connect P2 (V_{OUT}) to an oscilloscope/multimeter.
4. Connect a 20 V supply voltage to V_{IN} .
5. Press the PU or PD button for varying output voltage.
6. Press the ASE button to save a desirable output voltage upon power-up.

An Agilent E3631A supply was used to provide a 20 V input voltage. The output waveform from the [EVAL-CN0405-EB1Z](#) was captured using the oscilloscope, and the V_{RMS} voltage was measured using the Agilent 3458A multimeter.

A complete set of documentation for the [EVAL-CN0405-EB1Z](#) board, including schematics, layouts, and bill of materials, can be found in the [CN-0405 Design Support Package](#) at www.analog.com/CN0405-DesignSupport.

Figure 11 shows a photo of the board.

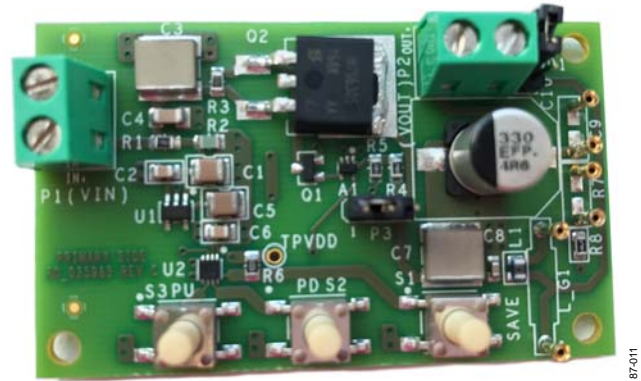

Figure 11. [EVAL-CN0405-EB1Z](#) Board Photo

LEARN MORE

CN-0405 Design Support Package:

www.analog.com/CN0405-DesignSupport

MT-031 Tutorial. *Grounding Data Converters and Solving the Mystery of "AGND" and "DGND"*. Analog Devices.

MT-091 Tutorial. *Digital Potentiometers*. Analog Devices.

MT-101 Tutorial. *Decoupling Techniques*. Analog Devices.

Kester, Walt. 1998. *Practical Design Techniques for Power and Thermal Management*, Section 3. Analog Devices.

Kester, Walt. 2009. *Practical Power Solutions*, Section 1. Analog Devices.

Limjoco, Aldrick. "Understanding Switching Regulator Output Artifacts Expedites Power Supply Design", *Analog Dialogue, Volume 48*. Analog Devices (August 2014).

Limjoco, Aldrick. AN-1144 Application Note. *Measuring Output Ripple and Switching Transients in Switching Regulators*. Analog Devices.

Data Sheets and Evaluation Boards

[AD5116 Data Sheet](#)

[ADCMP371 Data Sheet](#)

[ADP121 Data Sheet](#)

REVISION HISTORY

3/2017—Revision 0: Initial Version

(Continued from first page) Circuits from the Lab reference designs are intended only for use with Analog Devices products and are the intellectual property of Analog Devices or its licensors. While you may use the Circuits from the Lab reference designs in the design of your product, no other license is granted by implication or otherwise under any patents or other intellectual property by application or use of the Circuits from the Lab reference designs. Information furnished by Analog Devices is believed to be accurate and reliable. However, Circuits from the Lab reference designs are supplied "as is" and without warranties of any kind, express, implied, or statutory including, but not limited to, any implied warranty of merchantability, noninfringement or fitness for a particular purpose and no responsibility is assumed by Analog Devices for their use, nor for any infringements of patents or other rights of third parties that may result from their use. Analog Devices reserves the right to change any Circuits from the Lab reference designs at any time without notice but is under no obligation to do so.

©2017 Analog Devices, Inc. All rights reserved. Trademarks and registered trademarks are the property of their respective owners.
CN15187-0-3/17(0)

