

Circuits from the Lab™ Reference Circuits

Circuits from the Lab™ reference circuits are engineered and tested for quick and easy system integration to help solve today's analog, mixed-signal, and RF design challenges. For more information and/or support, visit www.analog.com/CN0218.

Devices Connected/Referenced

AD8212	High Common Mode Voltage, Current Shunt Monitor
AD8605	Precision, Low Noise, CMOS, Rail-to-Rail Input/Output Op Amp
ADuM5402	Quad-Channel Isolator with Integrated DC-to-DC Converter
ADR381	2.5V, Low Noise, High Accuracy, Band Gap Voltage Reference
AD7171	16-Bit Low Power Σ - Δ ADC

500 V Common-Mode Voltage Current Monitor

EVALUATION AND DESIGN SUPPORT

Circuit Evaluation Boards

[CN-0218 Circuit Evaluation Board \(EVAL-CN0218-SDPZ\)](#)
[System Demonstration Platform \(EVAL-SDP-CB1Z\)](#)

Design and Integration Files

[Schematics, Layout Files, Bill of Materials](#)

CIRCUIT FUNCTION AND BENEFITS

The circuit shown in Figure 1 monitors current in systems with high positive common-mode dc voltages of up to +500 V with less than 0.2% error. The load current passes through a shunt resistor, which is external to the circuit. The shunt resistor value is chosen so that the shunt voltage is approximately 500 mV at maximum load current.

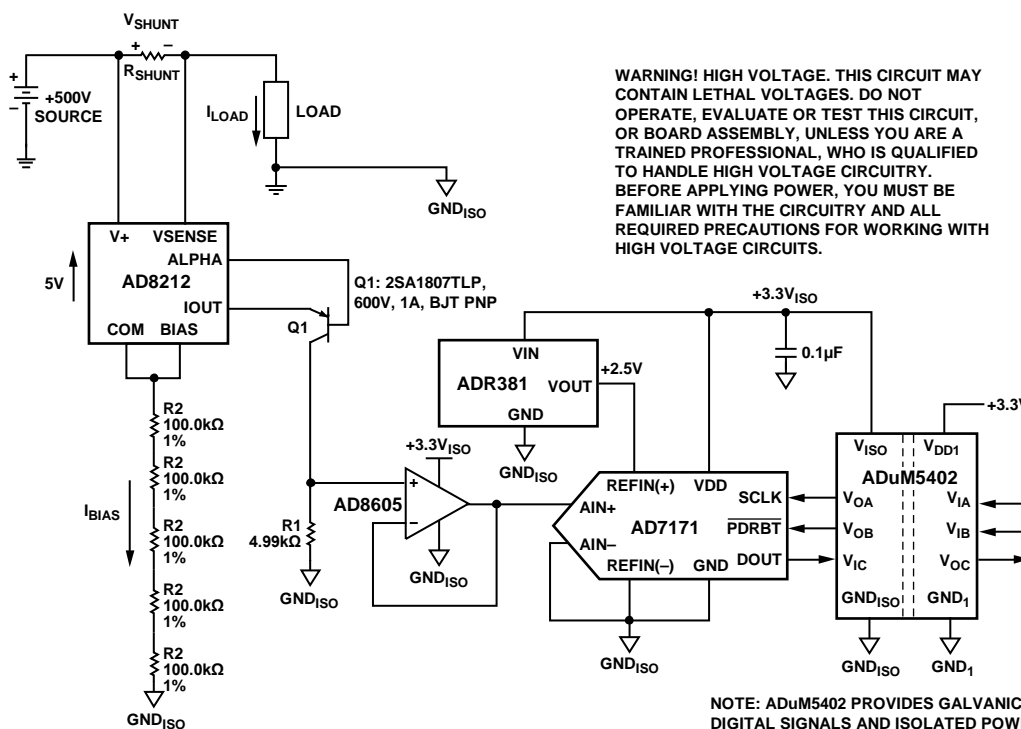

Figure 1. High Common-Mode Voltage Current Monitor (All Connections and Decoupling Not Shown)

Rev. B

Circuits from the Lab™ circuits from Analog Devices have been designed and built by Analog Devices engineers. Standard engineering practices have been employed in the design and construction of each circuit, and their function and performance have been tested and verified in a lab environment at room temperature. However, you are solely responsible for testing the circuit and determining its suitability and applicability for your use and application. Accordingly, in no event shall Analog Devices be liable for direct, indirect, special, incidental, consequential or punitive damages due to any cause whatsoever connected to the use of any Circuits from the Lab circuits. (Continued on last page)

The [AD8212](#) accurately amplifies a small differential input voltage in the presence of large positive common-mode voltages greater than 500 V when used in conjunction with an external PNP transistor.

Galvanic isolation is provided by the [ADuM5402](#) quad channel isolator. This is not only for protection but to isolate the downstream circuitry from the high common-mode voltage. In addition to isolating the output data, the [ADuM5402](#) digital isolator can also supply isolated +3.3 V for the circuit.

The measurement result from the [AD7171](#) is provided as a digital code utilizing a simple 2-wire, SPI-compatible serial interface.

This combination of parts provides an accurate high voltage positive rail current sense solution with a small component count, low cost, and low power.

CIRCUIT DESCRIPTION

The circuit is designed for a full-scale shunt voltage of 500 mV at maximum load current I_{MAX} . Therefore, the value of the shunt resistor is $R_{SHUNT} = (500 \text{ mV})/(I_{MAX})$.

The [AD8212](#) process has a breakdown voltage limitation of 65 V. For this reason, the common-mode voltage must remain below 65 V. By utilizing an external PNP BJT transistor, the common-mode voltage range can be extended to greater than 500 V, depending on the breakdown voltage of the transistor.

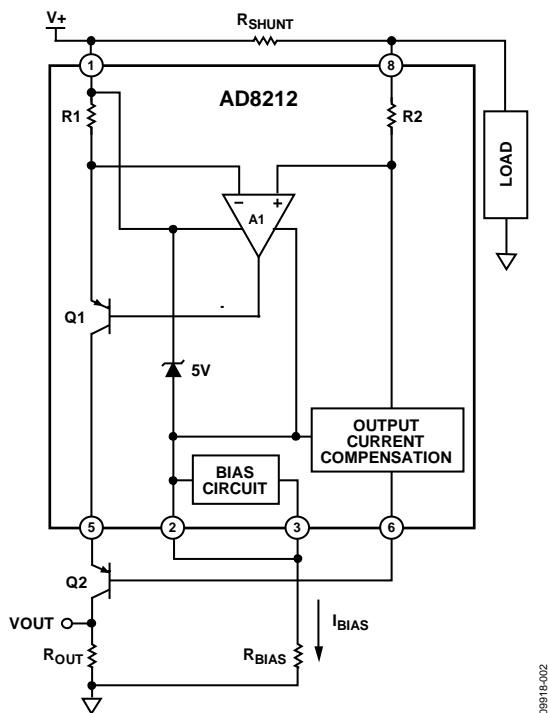

Figure 2. [AD8212](#) High Voltage Operation Using an External PNP Transistor

There is no dedicated power supply for the [AD8212](#). Instead, it creates a 5 V supply by essentially “floating” itself off the 500 V common-mode voltage by utilizing an internal 5 V series regulator as shown in Figure 2. This regulator ensures that at all

times the COM (Pin 2), which is the most negative of all the terminals, is always 5 V less than the supply voltage ($V+$).

In this mode of operation, the supply current (I_{BIAS}) of the [AD8212](#) circuit is based entirely on the supply range and the chosen value of the R_{BIAS} resistor. For example, for $V+ = 500 \text{ V}$, and $R_{BIAS} = 500 \text{ k}\Omega$,

$$I_{BIAS} = (500 \text{ V} - 5 \text{ V})/R_{BIAS} = 990 \mu\text{A},$$

In this high voltage mode, I_{BIAS} should be between 200 μA and 1 mA. This ensures the bias circuit is active, allowing proper operation of the device.

Note that the 500 k Ω bias resistor ($5 \times R2$) is made up of five individual 100 k Ω resistors. This is to provide protection from resistor voltage breakdown. Additional breakdown protection can be added by eliminating the ground plane immediately under the resistor string.

The load current flowing through the external shunt resistor produces a voltage at the input terminals of the [AD8212](#). Internal amplifier A1 responds by causing transistor Q1 to conduct the necessary current through resistor R1 to equalize the potential at both the inverting and noninverting inputs of the amplifier A1.

The current through the emitter of transistor Q1 (I_{OUT}) is proportional to the input voltage (V_{SENSE}) and, therefore, the load current (I_{LOAD}) through the shunt resistor (R_{SHUNT}). The output current (I_{OUT}) is converted to a voltage by using an external resistor, the value of which is dependent on the input-to-output gain desired in the application.

The transfer function for the [AD8212](#) is:

$$I_{OUT} = g_m \times V_{SENSE}$$

$$V_{SENSE} = I_{LOAD} \times R_{SHUNT}$$

$$V_{OUT} = I_{OUT} \times R_{OUT}$$

$$V_{OUT} = (V_{SENSE} \times R_{OUT})/1000$$

$$g_m = 1000 \mu\text{A/V}$$

The input sense voltage has a fixed range of 0 V to 500 mV. The output voltage range can be scaled according to the value of R_{OUT} . A 1 mV change in V_{SENSE} produces a 1 mA change in I_{OUT} , which, when passed through a 1 k Ω resistor, causes a 1 mV change in V_{OUT} .

In the circuit of Figure 1, the load resistor is 4.99 k Ω , thereby providing a gain of 5. A full-scale input voltage of 500 mV produces a 2.5 V output, which corresponds to the full-scale input range of the [AD7171](#) ADC.

The [AD8212](#) output is intended to drive high impedance nodes. Therefore, if interfacing with a converter, it is recommended the output voltage across R_{OUT} be buffered so that the gain of the [AD8212](#) is not affected.

Notice that the power supply voltage for the [ADR381](#) and the [AD7171](#) are supplied by the isolated power output (+3.3 V_{ISO}) of the [ADuM5402](#) quad isolator.

The reference voltage for the [AD7171](#) is supplied by the [ADR381](#) precision band gap reference. The [ADR381](#) has an initial accuracy of $\pm 0.24\%$ and a typical temperature coefficient of 5 ppm/ $^{\circ}\text{C}$.

Although it is possible to operate both the AD7171 VDD and REFIN(+) from the 3.3 V power supply, using a separate reference provides better accuracy. A 2.5 V reference is chosen to provide sufficient headroom.

The input voltage to the AD7171 ADC is converted into an offset binary code at the output of the ADC. The ADuM5402 provides the isolation for the DOUT data output, the SCLK input, and the PDRST input. Although the isolator is optional, it is recommended to protect the downstream digital circuitry from the high common-mode voltage in the case of a fault condition.

The code is processed in the PC by using the SDP hardware board and LabVIEW Evaluation software in Figure 3.

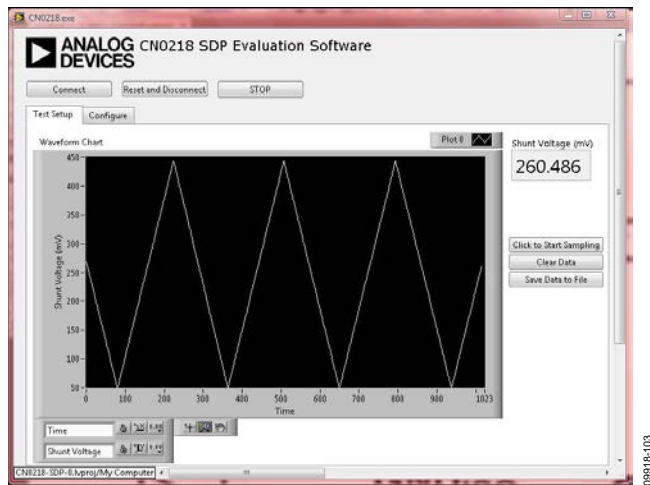

Figure 3. Evaluation Software Monitoring Test Circuit Shunt Voltage

The graph in Figure 4 shows how the circuit tested achieves an error of less than 0.2% over the entire input voltage range (0 mV to 500 mV). A comparison is made between the code seen at the output of the ADC recorded by LabVIEW and an ideal code calculated based on a perfect system.

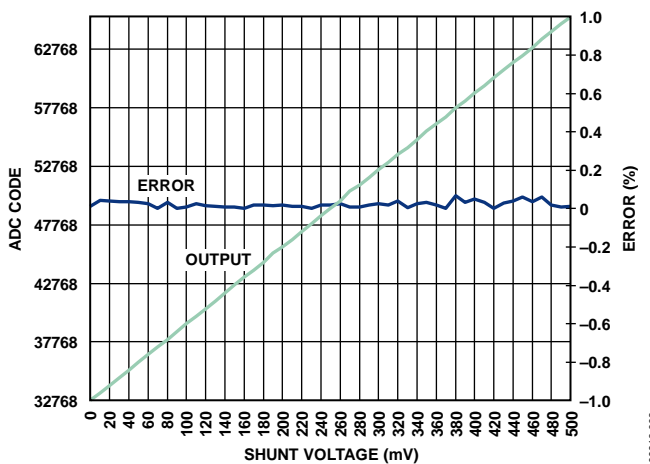

Figure 4. Plot of Output and Error vs. Shunt Voltage

PCB Layout Considerations

In any circuit where accuracy is crucial, it is important to consider the power supply and ground return layout on the board. The PCB should isolate the digital and analog sections as much as possible. This PCB was constructed in a 4-layer stack up with large area ground plane layers and power plane polygons. See the MT-031 Tutorial for more discussion on layout and grounding and the MT-101 Tutorial for information on decoupling techniques.

The power supply to the AD7171 and ADuM5402 should be decoupled with 10 μF and 0.1 μF capacitors to properly suppress noise and reduce ripple. The capacitors should be placed as close to the device as possible with the 0.1 μF capacitor having a low ESR value. Ceramic capacitors are advised for all high frequency decoupling.

Care should be taken in considering the isolation gap between the primary and secondary sides of the ADuM5402. The EVAL-CN0218-SDPZ board maximizes this distance by pulling back any polygons or components on the top layer and aligning them with the pins on the ADuM5402.

Power supply lines should have as large a trace width as possible to provide low impedance paths and reduce glitch effects on the supply line. Clocks and other fast switching digital signals should be shielded from other parts of the board by digital ground.

A complete design support package for this circuit note, including board layouts, can be found at www.analog.com/CN0218-DesignSupport.

COMMON VARIATIONS

There are a number of solutions available for high-side sensing of positive sources. IC solutions using current sense amplifiers, difference amplifiers, or a combination of these are available.

“High-Side Current Sensing: Difference Amplifier vs. Current Sense Amplifier,” *Analog Dialogue*, January 2008, describes the use of current sense and difference amplifiers. The article is available at www.analog.com/HighSide_CurrentSensing.

The following URLs link to Analog Devices products useful in solving the current sense problem:

Current sense amplifiers: www.analog.com/CurrentSenseAmps

Difference amplifiers: www.analog.com/DifferenceAmps

Instrumentation amplifiers: www.analog.com/InstrumentationAmps

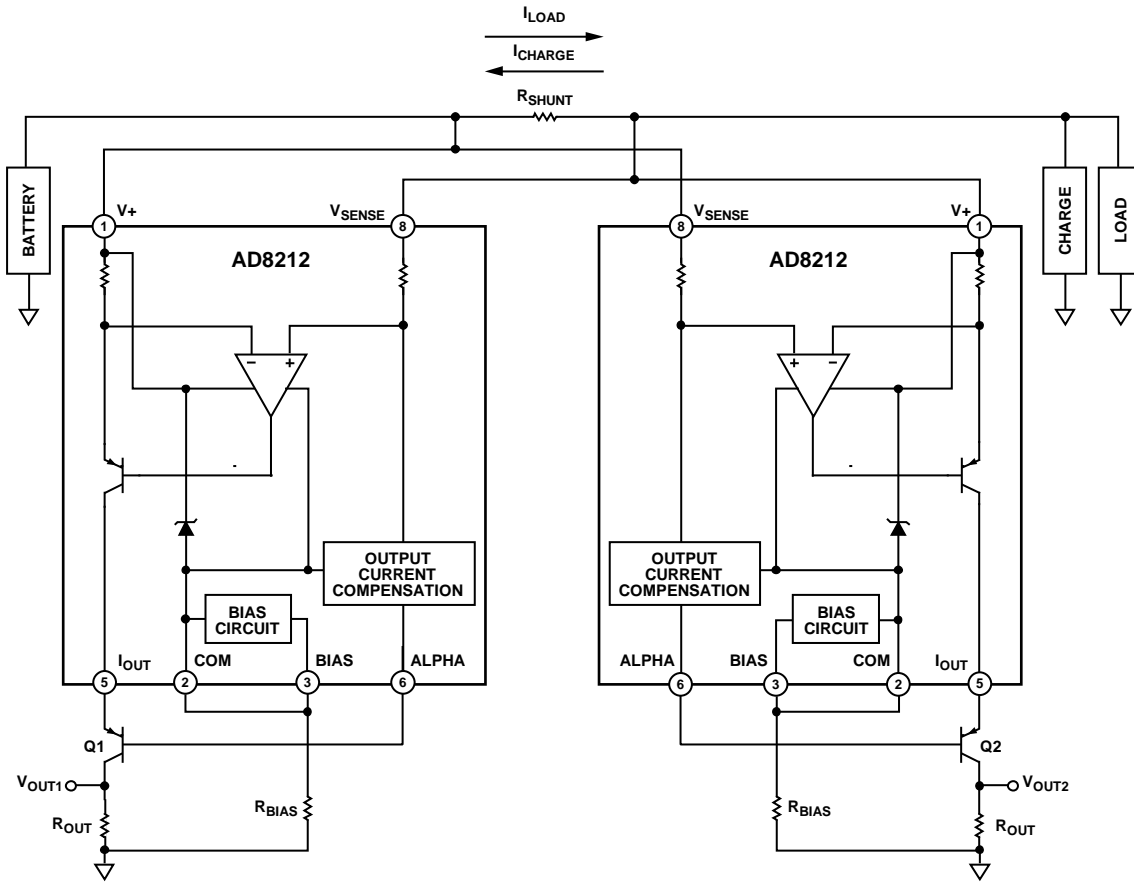

Figure 5. Bi-directional Current Sensing for Positive Common-Mode Voltages Greater than +65 V.

Figure 5 shows an alternate circuit, which can be used when a bidirectional current sense is required for positive common-mode voltages greater than +65 V. By implementing a second AD8212 in the configuration, one can measure the charge and the load currents, respectively. Note that V_{OUT1} increases as I_{LOAD} flows through the shunt resistor. V_{OUT2} increases as I_{CHARGE} flows through the shunt resistor.

CIRCUIT EVALUATION AND TEST

WARNING! HIGH VOLTAGE. THIS CIRCUIT MAY CONTAIN LETHAL VOLTAGES. DO NOT OPERATE, EVALUATE, OR TEST THIS CIRCUIT, OR BOARD ASSEMBLY, UNLESS YOU ARE A TRAINED PROFESSIONAL, WHO IS QUALIFIED TO HANDLE HIGH VOLTAGE CIRCUITRY. BEFORE APPLYING POWER, YOU MUST BE FAMILIAR WITH THE CIRCUITRY AND ALL REQUIRED PRECAUTIONS FOR WORKING WITH HIGH VOLTAGE CIRCUITS.

This circuit uses the EVAL-CN0218-SDPZ circuit board and the EVAL-SDP-CB1Z System Demonstration Platform (SDP) evaluation board. The two boards have 120-pin mating connectors, allowing for the quick setup and evaluation of the circuit’s performance. The EVAL-CN0218-SDPZ board contains the circuit to be evaluated, as described in this note, and the SDP evaluation board is used with the CN0218 evaluation software to

capture the data from the EVAL-CN0218-SDPZ circuit board, displayed below.

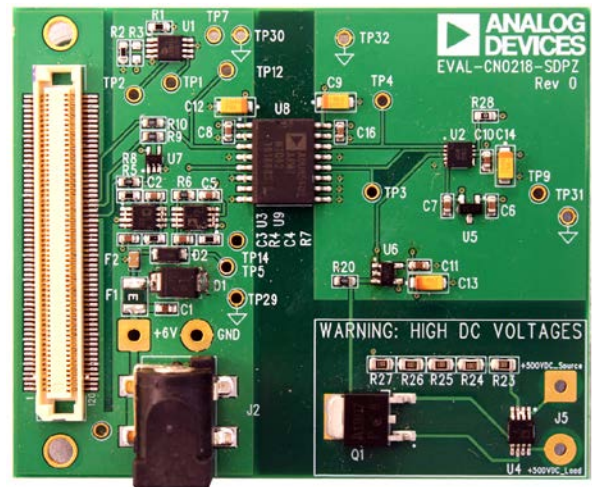

Figure 6. EVAL-CN0218-SDPZ PCB

Equipment Needed

- PC with a USB port and Windows® XP or Windows Vista® (32-bit), or Windows® 7 (32-bit)
- EVAL-CN0218-SDPZ circuit evaluation board
- EVAL-SDP-CB1Z SDP evaluation board
- CN0218 evaluation software
- Power supply: +6 V, or +6 V “wall wart”
- Shunt resistor with maximum voltage of 500 mV at the maximum load current.
- Electronic load

Getting Started

Load the evaluation software by placing the CN0218 evaluation software disc in the CD drive of the PC. Using "My Computer," locate the drive that contains the evaluation software disc and open the Readme file. Follow the instructions contained in the Readme file for installing and using the evaluation software.

Functional Block Diagram

See Figure 1 of this circuit note for the circuit block diagram and the EVAL-CN0218-SDPZ-SCH pdf file for the circuit schematics. This file is contained in the [CN0218 Design Support Package](#).

Setup

Connect the 120-pin connector on the EVAL-CN0218-SDPZ circuit board to the connector marked “CON A” on the EVAL-SDP-CB1Z evaluation (SDP) board. Nylon hardware should be used to firmly secure the two boards, using the holes provided at the ends of the 120-pin connectors.

Connect a shunt resistor across the input terminals (R_{SHUNT}) with a load to ground as indicated in Figure 1. With power to the supply off, connect a +6 V power supply to the pins marked “+6 V” and “GND” on the board. If available, a +6 V “wall wart” can be connected to the barrel connector on the board and used in place of the +6 V power supply. Connect the USB cable supplied with the SDP board to the USB port on the PC. Note: Do not connect the USB cable to the mini USB connector on the SDP board at this time.

It is important to connect the system ground and the PCB isolated ground to guarantee correct voltage levels and operation. Test point 31 and test point 32 give access to the GND_ISO required to properly make this connection.

Test

Apply power to the +6 V supply (or “wall wart”) connected to the EVAL-CN0218-SDPZ circuit board. Launch the evaluation software and connect the USB cable from the PC to the USB mini-connector on the SDP board.

Once USB communications are established, the SDP board can be used to send, receive, and capture serial data from the

EVAL-CN0218-SDPZ board. Data can be recorded for various values of load current as the electronic load is stepped.

Information and details regarding how to use the evaluation software for data capture can be found in the CN0218 evaluation software Readme file.

Information regarding the SDP board can be found in the [SDP User Guide](#).

LEARN MORE

CN0218 Design Support Package:

www.analog.com/CN0218-DesignSupport

Sino, Henri. “High-Side Current Sensing: Difference Amplifier vs. Current-Sense Amplifier,” *Analog Dialogue* 42-01, January (2008).

Cantrell, Mark. Application Note AN-0971, *Recommendations for Control of Radiated Emissions with isoPower Devices*. Analog Devices.

Chen, Baoxing, John Wynne, and Ronn Kliger. *High Speed Digital Isolators Using Microscale On-Chip Transformers*, Analog Devices, 2003.

Chen, Baoxing. *iCoupler® Products with isoPower™ Technology: Signal and Power Transfer Across Isolation Barrier Using Microtransformers*, Analog Devices, 2006

Chen, Baoxing. “Microtransformer Isolation Benefits Digital Control.” *Power Electronics Technology*. October 2008.

Ghiorse, Rich. Application Note AN-825, *Power Supply Considerations in iCoupler® Isolation Products*, Analog Devices.

Krakauer, David. “Digital Isolation Offers Compact, Low-Cost Solutions to Challenging Design Problems.” *Analog Dialogue*. Volume 40, December 2006.

MT-022 Tutorial, *ADC Architectures III: Sigma-Delta ADC Basics*, Analog Devices.

MT-023 Tutorial, *ADC Architectures IV: Sigma-Delta ADC Advanced Concepts and Applications*, Analog Devices.

MT-031 Tutorial, *Grounding Data Converters and Solving the Mystery of “AGND” and “DGND,”* Analog Devices.

MT-101 Tutorial, *Decoupling Techniques*, Analog Devices.

Wayne, Scott. “iCoupler® Digital Isolators Protect RS-232, RS-485, and CAN Buses in Industrial, Instrumentation, and Computer Applications.” *Analog Dialogue*. Volume 39, October 2005.

Data Sheets and Evaluation Boards

- [CN-0218 Circuit Evaluation Board \(EVAL-CN0218-SDPZ\)](#)
- [System Demonstration Platform \(EVAL-SDP-CB1Z\)](#)
- [AD8212 Data Sheet](#)
- [AD8212 Evaluation Board](#)
- [AD8605 Data Sheet](#)
- [AD8605 Evaluation Board](#)
- [AD7171 Data Sheet](#)
- [AD7171 Evaluation Board](#)
- [ADR381Data Sheet](#)
- [ADuM5402 Data Sheet](#)
- [ADuM5402 Evaluation Board](#)

REVISION HISTORY

5/13—Rev. A to Rev. B

Changes to Figure 1.....	1
Added Figure 3, Renumbered Sequentially	3
Added Figure 6.....	

11/11—Rev. 0 to Rev. A

Changes to Figure 1.....	1
Changes to Circuit Evaluation and Test	5

7/11—Revision 0: Initial Version

(Continued from first page) Circuits from the Lab circuits are intended only for use with Analog Devices products and are the intellectual property of Analog Devices or its licensors. While you may use the Circuits from the Lab circuits in the design of your product, no other license is granted by implication or otherwise under any patents or other intellectual property by application or use of the Circuits from the Lab circuits. Information furnished by Analog Devices is believed to be accurate and reliable. However, Circuits from the Lab circuits are supplied "as is" and without warranties of any kind, express, implied, or statutory including, but not limited to, any implied warranty of merchantability, noninfringement or fitness for a particular purpose and no responsibility is assumed by Analog Devices for their use, nor for any infringements of patents or other rights of third parties that may result from their use. Analog Devices reserves the right to change any Circuits from the Lab circuits at any time without notice but is under no obligation to do so.

