

D-Day [The Wit and Wisdom of Dr. Leif—4]

By Barrie Gilbert [barrie.gilbert@analog.com]

For Niku Yeng, August 29, 2025 came far too quickly; but for Dr. Leif, it was just another of his Daedalus Day events. He had started this series—always convened on the last Friday of each month, with the objective of providing a forum for the youngest Originators to present their unique perspectives—shortly after the founding, in 2018, of this Analog Devices campus, in Solna, a suburb of Stockholm. Why Solna? Some believe it was ADI's decision, being quite close to customers in northern Europe and Russia. Others think it was simply Leif's hometown, and if he wished to establish a new design center there, that was good enough for the Company. It wasn't the first time.

Presentations such as D-Days are instantly available at all ADI sites worldwide and are automatically archived. It is understood that information contained in every technical presentation and review (like the ruthlessly probing Design Scrutiny) represents the lifeblood of any company at the fringes of nanotronics. To allow it to be quickly forgotten would be as irresponsible as the old practice of incinerating 'waste' materials or burying them in landfills. Recycling philosophy today is radically different from the short-minded practices pervasive at the turn of the century. Nowadays, a subscriber to the Global Used Materials Registry can readily locate over 85% of the world's recycled materials.

Usually convened in the Michael Faraday auditorium, D-Days are always well attended by the local audience; but this morning many late arrivals had to stand at the back, or on the side steps. Curiosity to watch how a 'new guy' might fare always ran high. Today it was a 'new gal,' so an extra dash of excitement stirred among the male contingent, roughly two-thirds of the total. All these auditoriums were equipped with imaginative technology for enabling and enhancing effective presentations. In planning the campus, Leif proposed that their neuromorphic simulators, impressive and inspiring showpieces as well as active partners, be located in full view at the front of the largest auditoriums.

This choice was partly dictated by their size: a *General Electro-optical Emulator* (GE[°]E) was bulky, due to the space required for the dense 3D webs of opto-connection fibers for the concurrent information paths. Unlike the old digital machines, a GE[°]E is not a mindless number cruncher. Rather, the *processes* active within it are an *inseparable, organic* aspect of its structure. Each *is* a GE[°]E, having a unique personality and its own repertoire of individually learned problem-solving tricks and philosophies. However, these are unobtrusive—users see a uniform I/O image, at least on most days ... So it is appropriate that the little ID plate, discreetly attached to the fascia by Neuromorphix Inc. shows the simulator's *personal name*, not that of the manufacturer. Here, it is the MF-GE[°]E, informally Michaday, more cozily Micha: one of the smaller GE[°]Es on campus, having some 3 million hacks. Few today can remember how this term arose. It is a *hybrid analog computing kernel*, a neuromorphic emulator ASIC, with 8192 intraconnected analog array processors, comparable to a 1-mm² patch of human cortex but quite incapable of autonomous 'thought' (as is the patch of cortex—although that begs the question). In circuit-simulation studies, each hack assumes the behavioral characteristics of an individual element, such as a transistor, in the user's circuit.

The GE[°]E designers weren't lacking a sense of humor, some of which leaked into each unique—and playful—platform, as well as into the Manual. On p. 72 we read: "Hacks are organized into groups, each representing a user's network to be simulated, by a *Matrix Attach Designator and Description Organizer*, MAD^DO_G, while the actual interconnections are set up by St.VITZ, the *State Variable Intertwining Zoner*. Details of the IC processes, stimuli, and all other essential data are loaded into the job-specific hacks by *Feed Units for Parameters* (FedUPS). The fast analog results are optionally delivered to a *Pre-Output Unit Processor* (POP^{UP}) for numerical purification and sanitization, using conventional matrix methods." (Purification? Sanitization!?)

"The GE[°]E dynamically selects heuristics and accelerators from its personally-acquired repertoire. Every job can access over 250 HURRYUPS (*Handler Unit for Redeploying Unused Paths*)

which minimize solution time; 32 *Tactical Units For Technical Explication* (TUFTE) optimize how each type of simulation result is presented to maximize insight content; its *Multilingual Speech Engine*, MUSE, can accept verbal inputs from users and generate a same-language or translated response (or requested data), using its *Ubiquitous Text Transformer* (UTTER) ..." and so on.

At the bottom of a GE[°]E cabinet, with the comms agents, fiber-optic ports, silent power-management modules, and other riffraff, is a dusty nest of totally unimaginative binary CPUs. While tiny, fabricated in 16 nm, their lust for line power, so much more than all the rest of a GE[°]E combined, and so hugely out of proportion to their contribution to its function, can only be called distasteful.

Dr. Leif's breezy preamble began right on time. "Good morning, fellow travelers! Today, it's my distinct pleasure to introduce Dr. Niku Yeng, who will be describing her work concerning how an RF oscillator starts up from cold. You may perhaps be thinking this is a very simple topic, but Niku will remind us how complex the behavior of a small analog circuit can be when it is examined closely, and more thoroughly than found in most textbooks. As you know, at ADI we place a strong emphasis on the *learning experience*. It's as much a 'product' as the silicon we sell.

"I must also tell you that Niku undertook this work without any prompting. Great advances have never come from one who must be *asked*. More than a century ago, in his book *The Art of Living*, Wilfred A. Peterson said '*[A] Decision is the courageous facing of issues knowing that if they are not faced problems will remain forever unanswered. [It] is the spark that ignites Action. Until it is made, nothing happens.*' Today, our best products, and those going right back to our novel ICs of the 1970s, have come from those who *independently* selected some challenge and immersed themselves in it. They know no other way to pursue their craft than by *tracking trends and anticipating the future*. Then, ignoring all naysayers and using whatever subterfuges may be required, they *bring into existence* a product providing a *new function*, perhaps years ahead of any market demand. It is *this*, not mere Invention (which is invariably a *fleeting moment*) that alone may be called Innovation, the arduous *process* of turning thinking into things.

"I recall how reluctant were our valiant marketing folks to accept such a *fait accompli*! But those Pied Piper products often created whole *new families*, even *new businesses*. Many of mine are *still* alive, after decades of profitability. So please—don't hold back! Have the courage of your deepest convictions! You may make a few mistakes at first, but you must *always follow your instincts*—and seek ways to convert your clever ideas into tangible realities. Alright, well, that's quite enough from me! I'm sure you'll enjoy this talk, and benefit from Niku's exemplary work ethic and her unusual way of thinking. So now, young Yeng, it's your turn!"

Feeling more poised than she had expected, perhaps because her faithful companion Micha was right behind her, ready to assist with the presentation, Niku began with an icebreaker.

"Thank you, Dr. Leif, and good morning, everyone! First, in case you are wondering about my mixed-up name, let me explain. My Chinese father was on business in Bangalore the day I was born in Oulu, Finland, and my Iranian mother chose my Persian name. We moved to Solna when I was about six. I must have spent my childhood in a perpetual state of perplexity because, ever since, I have always been attracted to anything enigmatic or anomalous.

"Although I'm a relative newcomer to ADI, I already consider myself fortunate in being able to tap into the wisdom of Dr. Leif, who taught me about the *Four Dees*. Let's see: Analog circuits are Durable, Diverse, and ... oh yes, Dimensional. However, he left me to find out for myself that this domain of design is at times deceptively Difficult, and demands Determination, Drive, and Dedication to deal with dozens of dastardly devious and daunting Details!"

The smiles of acknowledgement rustling around the audience assured her that she'd overcome the first barrier to acceptance.

"Oscar, as I call my oscillator, is a basic LC-tuned, differential topology using a simple BJT negative-impedance cell—an NIC. The small-signal behavior of the CMOS version will be similar; but differences appear as the oscillator approaches its eventual cyclostationary end-state, particularly for large overdrives. The fundamentals of the BJT make analysis far easier for this state.

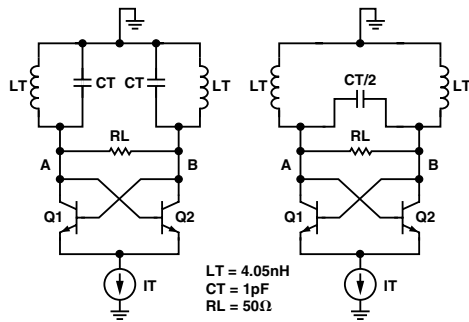

Slide 1. Two forms of the basic Oscar.

“Micha, first slide, please. Thank you. As you see, there are two forms of the basic Oscar. Both are innocent looking, aren’t they? Almost all basic analog cells have deceptively simple topologies. But, as you know, their behavior is complex and the explanations found in textbooks are frequently incorrect or, at best, superficial and inadequate for any serious design work. I must admit that, at the start of my studies, I had no idea of how many winding lanes and back alleys Oscar would lead me down. But, in the process, I have gained many rewarding and unexpected personal insights.

“Initially, the question was simply this: does Oscar start because of an *external disturbance*—a ‘supply glitch’? Or rather, is this process driven by *internal noise*? Any oscillator that’s expected to provide a spectrally clean output can’t afford to be susceptible to supply hash; this is the first reason for using *fully symmetrical* circuits. The second reason is to minimize even-order harmonics. In an ideal, perfectly balanced cell, the start-up process can only be driven by *noise amplification*. But all practical circuits have mismatches so bias sensitivities are inevitable; even a minuscule mismatch could be the dominant destabilizing factor. Therefore, both noise *and* circuit mismatches can drive this process. So the question becomes: How do these two influences compare in their power to shake Oscar from his slumbers?

“Noise is analytic and can readily be quantified, with or without the help of Micha;” (Niku thought she detected a tolerant sigh behind her) “whereas the impact of device mismatches can only be assessed by making *assumptions*, about their types and their magnitudes, for a small subset of possibilities. So my objective took another turn: Could I demonstrate that noise is *invariably the dominant* driving force behind startup, even in the presence of significant mismatches? That is clearly the desired outcome, because it provides a reasonable assurance that, if nothing else, our choice of *circuit topology* is probably as good as it gets.

“In these cells, the only power source is the tail current, I_T , thus avoiding questions of supply sequencing. We can experiment in a number of ways: I_T can appear abruptly, that is, in a time much less than the tank’s period—400 ps with the values shown—or slightly to much longer, and with or without mismatches added.

“Putting aside the ‘glitch postulate’ for the moment, let’s try to understand whether noise alone could be the culprit, by ramping I_T very slowly. It makes only a little difference which form of Oscar we use—and even, in moderation, whether we include any mismatches. We must examine the *voltage noise spectral density* and *total integrated noise* at the output A, B *right at the resonant frequency*, since it has a hyperfine width of only microhertz, as this current reaches its critical value. So, Micha, please run some examples of this for us, up to and beyond I_{CRIT} . By the way, what is I_{CRIT} , and the resonant frequency, at this current?”

“Roughly stated, the resonance at 300 K, with $R_L = 50 \Omega$, is at 2.500002364296 GHz for an I_{CRIT} of 2.0681008663033986 mA,” piped up Micha, “and I’ve also found that the line width at 50% power level is about 19.22157 μ Hz, and that numerically the VSND and rms cross over at roughly 11 (V/Hz or V rms).”

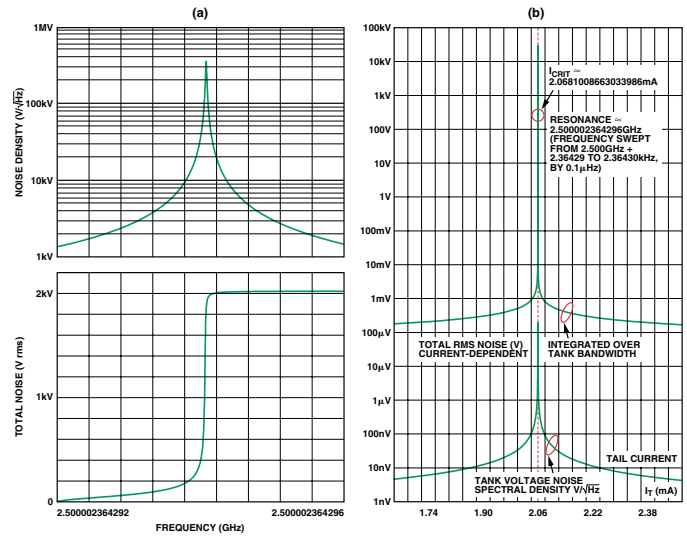

Micha 1. VNSD and rms noise (a) vs. frequency, at $I_T = I_{CRIT}$ and (b) vs. I_T for values just above and below I_{CRIT} .

“Well, thank you, Micha, for those, um ... observations. What we should especially note here is that the basic noise sources in this circuit, which I will later identify and quantify, are amplified to extremely high values of *voltage noise spectral density*, across the nodes A-B; likewise, the total rms noise, integrated over the actual, very narrow resonance bandwidth, attains an improbably high value. But this is simply the inevitable consequence of the *closed-loop gain* briefly reaching infinity. The plot on the right shows how the VSND and rms noise vary, as the tail current is varied slightly below or above I_{CRIT} —where they again decline.”

“The apparently high noise levels just indicate that the negative-impedance converter comprising Q1, Q2, and their current tail, in conjunction with the resistive component of its load, $R_L = 50 \Omega$, exhibits an *open-loop gain* that rises to *unity* at I_{CRIT} . Thus, the *closed-loop gain* briefly becomes *infinite*. But, even at this value, an oscillation can’t build up in amplitude, since if it tried to, the *nonlinearity* of the incremental r_e of each transistor, $kT/q(I_T/2)$ at balance, quickly *raises their sum*, $kT/qI_{C1} + kT/qI_{C2}$, to above the permissible maximum, $4kT/qI_{CRIT}$, during each cycle.

“Perhaps now it’s apparent why the critical current is 2.086 mA. Do you see? It’s because the total incremental emitter resistance is $4 \times 25.85 \text{ mV}/2.086 \text{ mA}$, which is 50Ω , the load resistance at 300 K, while at resonance the parallel-tuned tank behaves like an open circuit. So now, Micha, show us the tank voltage in the *time domain* at precisely I_{CRIT} following its appearance with an onset time of, say, 1 ns. First, switch off your stochastic noise sources, and then repeat the experiment with them active.”

Micha demurred. “Well, there’ll be nothing much to show either way because, with no noise, the fully balanced circuit will never start; and even with my stochastic noise sources switched on, it will take over 14 hours to show significant signs of life, because the resonance bandwidth is only $\sim 19 \mu$ Hz. Do you have that long?”

“Ah, Micha! You’re good at many things, but not talented when it comes to thinking things through! That hyperfine resonance is present *only* when the tail current is *exactly* I_{CRIT} . In rising from zero, the loop gain gradually increases; but, as it passes through lower currents, the resonance bandwidth is much higher and the loop response is proportionally faster. Alright? So now Micha, please run my time-domain experiment, but let’s take the tail current just a little bit past I_{CRIT} , say, to 2.1 mA.”

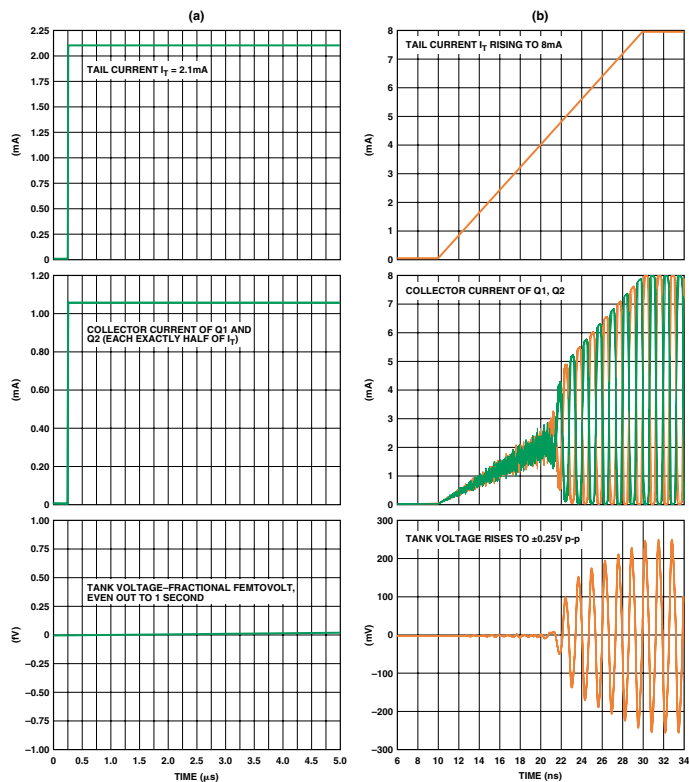

Micha 2. The time-domain response of the full-balanced Oscar, (a) with stochastic noise processes excluded and (b) included.

“As you see, a huge ‘glitch’—in fact, the full onset of the tail current—fails to wake up a perfectly balanced Oscar, while the internal noise, amounting to rms values that readily reach many volts, and included here by Micha’s complete modeling of noise as a process in time, evidently cause a very rapid startup. But we’ve a lot more to study, before reaching our final position.”

A voice was raised from the back of the hall, “Why do you rely so much on simulation, when a more satisfying answer ought to come from an algebraic analysis?” asked the speaker.

“That’s a fair question, although I’m not sure what constitutes a satisfying answer. I’ve learned from Dr. Leif to simulate first, then address the analytical issues later. This is not indicative of laziness, or weak-headedness, as was once so widely believed—vehemently—by a few analog diehards decades ago. In my own experience, and everyone’s I expect, much precious time can be saved in trying to develop a general theory, by first spending a few minutes studying a number of special cases by simulation. This time helps us to realize both the scope of possibilities and the circuit’s limitations; and we are led forward, not always to the analytical solution we may have been seeking, but to deeper insights than typically come out of many tedious pages of error-prone algebra. Further, the mathematics is frequently intractable in highly nonlinear circuits, even though very simple, like Oscar.

“On the other hand, in pursuing this approach (which some still adamantly call ‘tinkering’) it’s inadmissible to accept Micha’s answers without verification,” (another sigh from behind) “and without any personal understanding of what the answers mean, that is, without asking Why?, or without extending one’s special case to the more general case. Bursts of insight can transport you into wild new realms of invention; but you must assimilate these insights, and organize them, if you wish to become their master!”

Dr. Leif was beaming, not at all surprised that Niku’s intensity was so unashamedly visible. But the audience wasn’t sure what to make of this impassioned outpouring; she was “preaching to the choir.” The

auditorium clock had no doubts: flashing orange at the fingertip of its minute hand, it informed Niku that she had spent fifteen minutes saying little of substance. Then, standing four-square in front of her coworker, Michaday, Leif’s zealous young protégé did something that amazed even him.

“I knew that I was going to have a hard time including in a one-hour talk even a small selection of all the issues comprising my recent studies, so I have asked Micha to pick up my presentation here. He will talk at normalratetimestwo, so pay close attention!”

Clever kid! thought Leif. What a liberty! thought the audience.

“Thank you, Nicky,” began Michaday, speaking in single-time. (Oh-ho! so it’s ‘Nicky’ now, gasped the stunned audience, some thinking: He never calls me by my nickname!). “In picking up this presentation, I will repeat it just as Dr. Yeng delivered it to me, last night, except for the time-compression factor.” Then, switching to zeropitchshiftnormalratetimestwo, Michaday said, “Let’s now examine the effect of element mismatches.”

Absorbing technical material in double-time was no novelty to the audience; many were quite used to triple-time. But Niku’s artful subversion had left several people feeling that this was cheating. They had come to watch the Niku girl coping with her first D-Day presentation, not listen to a clever box of wires. As the smoldering dissent spread, it grew exponentially, like Oscar’s noise, and soon became palpable enough to cut with a knife.

“This next study will show some re-re-re-re-re ...”

Leif had sensed the audience’s unease and, using his privileged veto over “improper use of facilities,” he interrupted Michaday’s gleeful takeover with one transponder click. Before standing, he thought for a moment how best to handle this delicate impasse, not wishing to sound critical, or undermine Niku’s clever ruse.

“Dr. Yeng, I’m confident that Michaday will be faithful to your material, and won’t pull a HAL on you.” Those aware of the old movie grinned broadly at so delightful a prospect. “But we came to hear you, and I suggest we can afford the time, this morning, to take in your material at Niku_in_single_time.”

Everyone laughed, relieved to see that the respected guru was still fully in charge. Blushing like an Arizona sunset, Niku said, “I’m really very sorry, Dr. Leif. To tell the truth, I was hoping to capitalize on my discovery of how extraordinarily accomplished our GE^{Es} are, and to allow my good companion Micha to be in the limelight for a while. But I see that this was presumptuous of me, and I apologize to you—and everyone.”

With that, she picked up where Micha was left in mid-sentence.

[For the conclusion of Niku’s talk about Oscar, and all of Micha’s slides, please visit <http://www.analog.com/library/analogdialogue/leif1.html>].

Barrie Gilbert, the first-appointed ADI Fellow, has “spent a lifetime in pursuit of analog excellence.” Barrie was born in Bournemouth, England, in 1937. Before joining ADI, he worked with first-generation transistors at SRDE in 1954. At Mullard, Ltd., in the late ’50s, he pioneered transistorized sampling oscilloscopes, and in 1964 became a leading scope designer at Tektronix. He spent two years as a group leader at Plessey Research Labs before joining Analog Devices in 1972, where he is now director of the Northwest Labs in Beaverton, Oregon. Barrie is a Life Fellow of the IEEE and has received numerous service awards. He has about 70 issued patents, has authored some 50 papers, is a reviewer for several professional journals, and is a co-author or co-editor of five books. In 1997, he was awarded an honorary doctorate of engineering from Oregon State University.

