

This Should Work: Thermistor Senses Liquid Levels

By John Wynne [john.wynne@analog.com]

In [precision temperature measurement](#) applications using thermistors, RTDs, or other resistive temperature sensors, care must be taken to avoid errors due to self-heating of the sensor by the excitation current. In some applications, however, the self-heating effect can be put to good use. The following design concept *should* work, but it has not been fully tested.

When a thermistor is driven by a voltage source, it heats up. If submerged in a liquid, its temperature, and therefore its resistance, will remain relatively constant—as long as the liquid temperature remains relatively constant. If the liquid level drops, however, the thermistor becomes exposed, the heat dissipating effect of the liquid vanishes, the temperature rises, and—for a positive-TC element—the resistance increases. This can be easily detected and flagged by the [ADM4850](#) low-cost half-duplex differential line transceiver. The differential outputs are useful when the level-alert signal must be transmitted to remote annunciators such as LEDs. The transceiver's prime use is in multipoint data communications, so its outputs provide short-circuit protection, thermal shutdown, and slew-rate limiting to reduce EMI.

We want to know when the liquid in a container is above or below a specific level. As shown in Figure 1, a thermistor is positioned at this level. When submerged, the thermistor resistance is relatively low. The ratio R_t/R_A is chosen so that the voltage at the driver input is interpreted as logic 0. When the thermistor is uncovered, the input voltage increases rapidly, crosses the input threshold voltage, and is interpreted as logic 1. The receiver output can be tied to the driver input through resistor R_B if hysteresis is required.

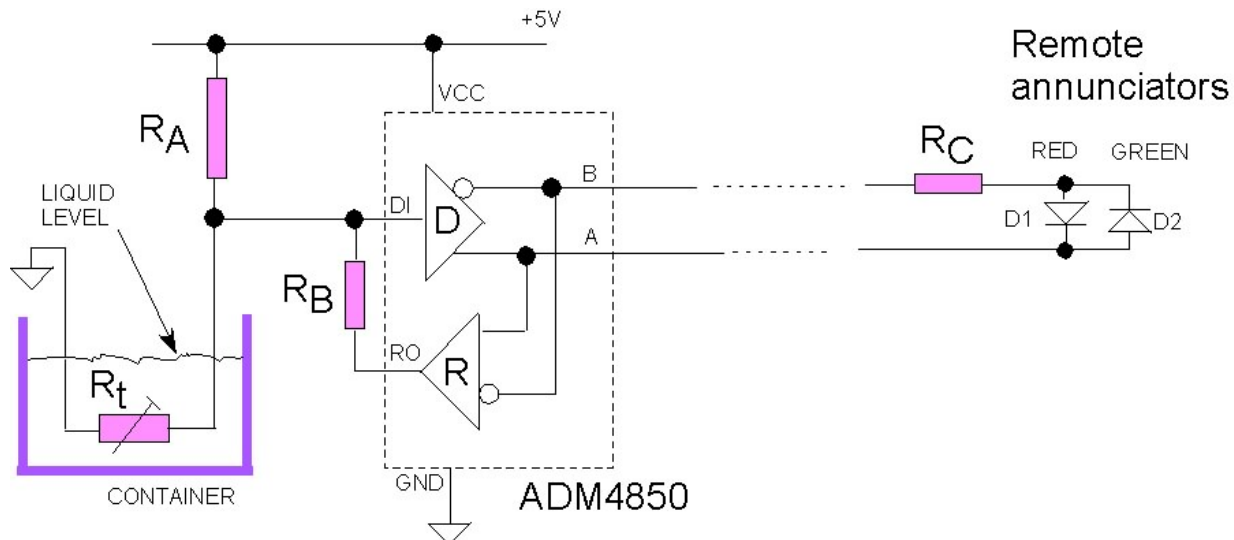

Figure 1. Thermistor senses when liquid is above or below a preset threshold.

Reliable operation of this circuit depends on the input threshold stability—which is not specified on the datasheet—and on the voltage excursions produced by R_t and R_A as the critical liquid level is crossed. Characterization data for the ADM4850—over a number of lots, a 4.75-V to 5.25-V power-supply range, and a -40°C to $+85^{\circ}\text{C}$ temperature range—shows that an input voltage $\leq 1.15\text{ V}$ will be seen as logic 0 and that an input voltage $\geq 1.42\text{ V}$ will be seen as logic 1.

The thermistor suggested for this application—an EPCOS type [D1010](#) ceramic PTC device intended for use as a level sensor—offers a resistance that tracks closely with the thermal conductivity of the ambient medium. The R/T curve for this thermistor type rises extremely steeply once the threshold temperature has been reached. Available in a stainless steel case, it is corrosion-proof to fuels, solvents, and other liquids found in harsh environments.

The value of R_A depends on the temperature of the liquid and the surrounding air. The worst case conditions occur when the liquid is hot and the air is cold. From the D1010 datasheet, a standard value of $909\ \Omega$ for R_A is a good choice to operate in liquids up to $+50^\circ\text{C}$ and air down to -25°C . Samples of the D1010 measure approximately $149\ \Omega$ at room temperature with no excitation.

In industrial applications, a fault might expose R_A or R_t to a lethal high voltage. In these cases, consider the [ADM2483](#) transceiver, an isolated version of the ADM4850. This half-duplex differential bus transceiver integrates galvanic isolation that can withstand $2.5\ \text{kV rms}$ for 1 minute. An isolated power supply is required to drive the hot side of this device.